



EBD6012 series

12V / 5A Wall mounted type AC/DC adaptor

■ Features:

- Universal AC input / Full range
- Wall mounted type, Isolation class II design
 - ErP step II / CEC level VI compliance
 - No load power consumption $P < 0.25W$
- Protections: Overload / Short circuit / Over Temperature



ELECTRICAL SPECIFICATION

MODEL	EBD6012
-------	---------

OUTPUT

Rated Voltage	12V
Rated Current	5A
Current Range	0 ÷ 5A
Rated Power	60W
Line Regulation	± 2%
Load Regulation	± 5%
Tolerance [3]	± 8%
Ripple & Noise (max.) [2]	200mV _{p-p}
Setup, Rise Time [4]	1000ms, 20ms / 230VAC at full load
Hold up Time (typ.)	10ms / 230VAC at full load

INPUT

Voltage Range	90 ÷ 264VAC
Frequency Range	47 ÷ 63Hz
Efficiency (typ.)	90.33%
AC Current (typ.)	0.69A / 115VAC, 0.5A / 230VAC
No load Power Consumption (max.)	0.25W

PROTECTIONS

Overload	Range: 110 ÷ 150% Type: hiccup mode, auto-recovery.
Short Circuit	Type: hiccup mode, auto-recovery.
Over voltage	Range: 12 ÷ 19V Type: hiccup mode, auto-recovery
Over temperature	Type: hiccup mode, auto-recovery



EBD6012 series

12V / 5A Wall mounted type AC/DC adaptor

WORKING ENVIRONMENT

Working Temperature	0°C ÷ 40°C
Working Humidity	10 ÷ 90% RH non-condensing
Storage Temperature and Humidity	-20°C ÷ 85°C, 5 ÷ 90% RH non-condensing

SAFETY and EMC REGULATIONS

Safety Standards	Compliance to EN 62368
Withstand Voltage	IN/OUT: 3.6kVAC
Isolation Resistance	IN/OUT: 100MΩ/500VDC/25°C/70%
EMC Emission	Compliance to EN55032
EMC Immunity	Compliance to EN61000-4-2, -3, -4, -5
Harmonic Current	Compliance to EN61000-3-3; EN61000-3-2

OTHERS

Wire and plug	Wire: 20AWG, length = 105cm ±50mm	Plug: IEC C8
	Wire: 18AWG, length = 125cm ±50mm	Plug: 2.1/5.5, positive inside
Dimensions	115 x 74 x 31mm (L x W x H)	
Net Weight / gross	205g / 292g	

1. All parameters NOT specially mentioned are measured at 230VAC input, rated load and 25°C of ambient temperature.
2. Ripple & noise are measured at 20MHz of bandwidth by using a 12" twisted pair-wire terminated with a 0.1μF i 47μF parallel capacitor.
3. Tolerance includes set up tolerance, line regulation and load regulation.
4. Setup and rise time is measured from 0 to 90% rated output voltage.
5. Power supply is considered as component not indented to apply by end-user. Power supply meets safety and EMC standards however the final equipment with power supply must be re-quality to comply with EMC Directives.

MECHANICAL SPECIFICATION

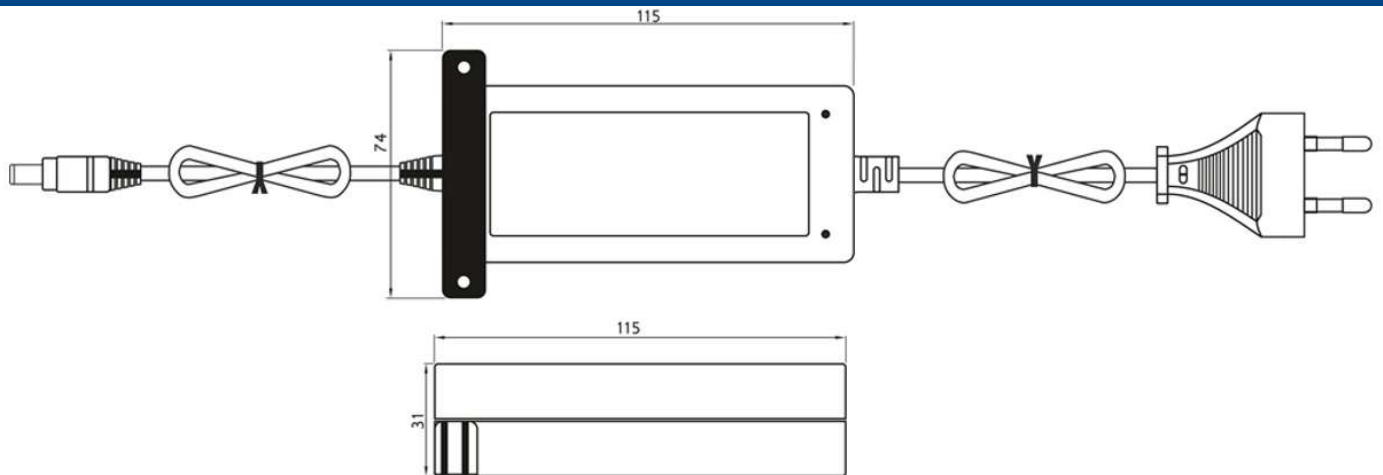



EBD6012 series

12V / 5A Wall mounted type AC/DC adaptor

MECHANICAL SPECIFICATION - Wire and plug

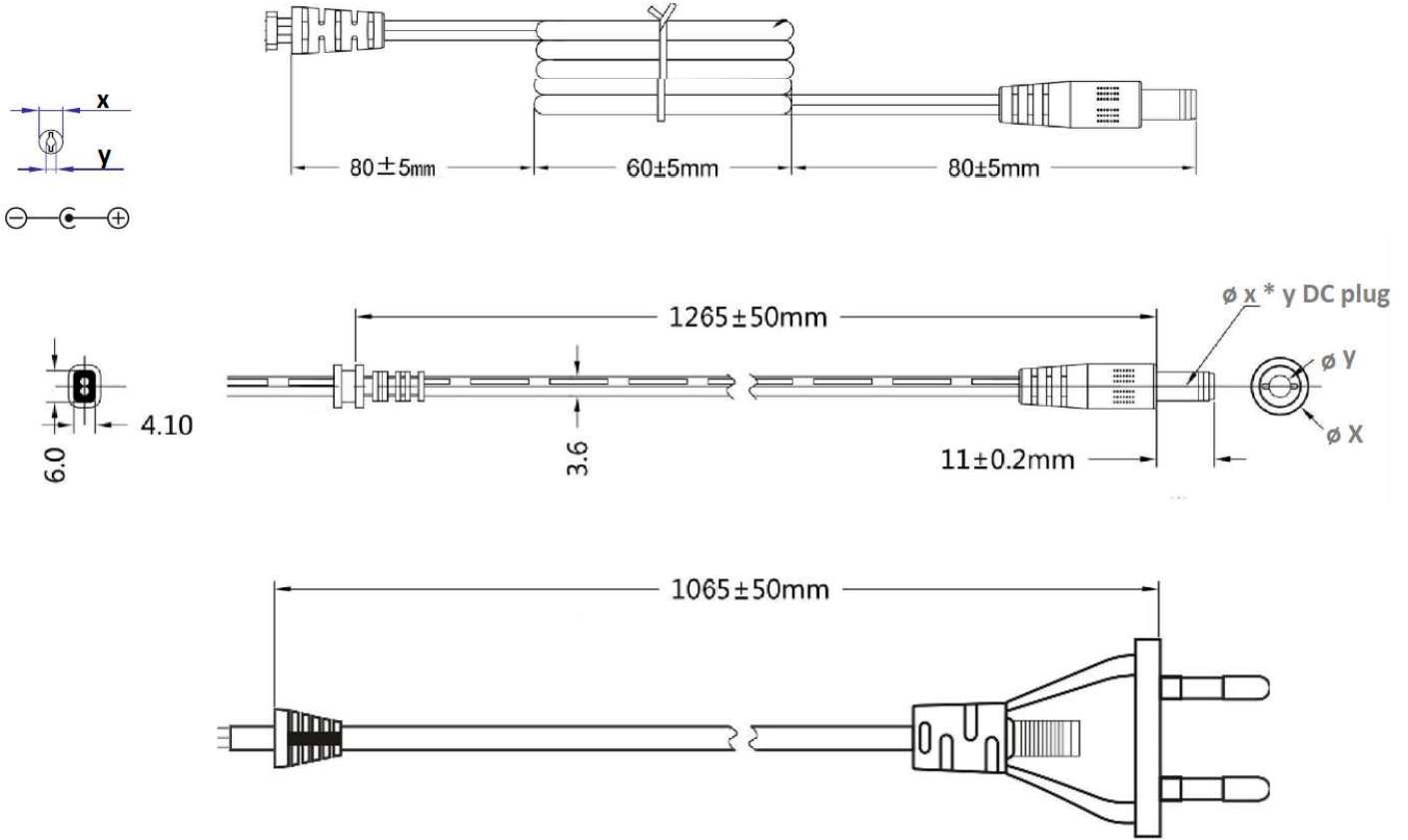

*MODEL	DC PLUG	X [mm]	Y [mm]	Polarity
EBD6012-EB	5.5x2.1mm	5.5	2.1	center positive
EBD6012-25	5.5x2.5mm	5.5	2.5	center positive
EBD6012-13	3.5x1.3mm	3.5	1.3	center positive
EBD6012-40	4.0x1.7mm	4.0	1.7	center positive
EBD6012-48	4.8x1.7mm	4.8	1.7	center positive
EBD6012-CN	5.5x2.1mm	5.5	2.1	center negative
EBD6012-25-CN	5.5x2.5mm	5.5	2.5	center negative
EBD6012-13-CN	3.5x1.3mm	3.5	1.3	center negative
EBD6012-40-CN	4.0x1.7mm	4.0	1.7	center negative
EBD6012-48-CN	4.8x1.7mm	4.8	1.7	center negative