



Cultivo

INSTRUKCJA MONTAŻU

Szklarnia aluminiowa z poliwęglanu
Szerokość 244 cm, długość 490 cm, wysokość 230 cm



WAŻNE!

Przed montażem należy uważnie przeczytać wszystkie instrukcje. Najlepiej zapoznać się z częściami i zebrać odpowiednie części do każdego kroku. www.cultivo.com.pl

PLATFORMA

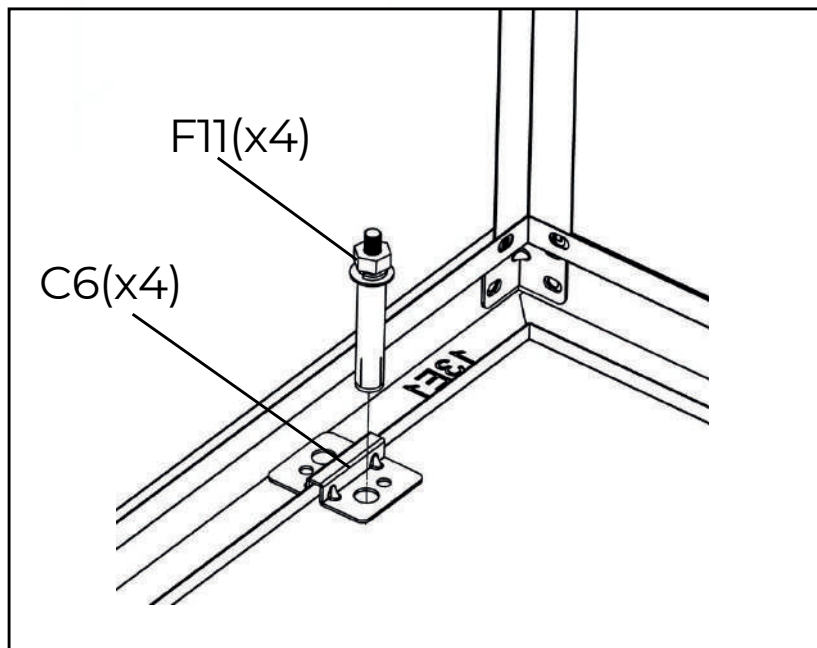
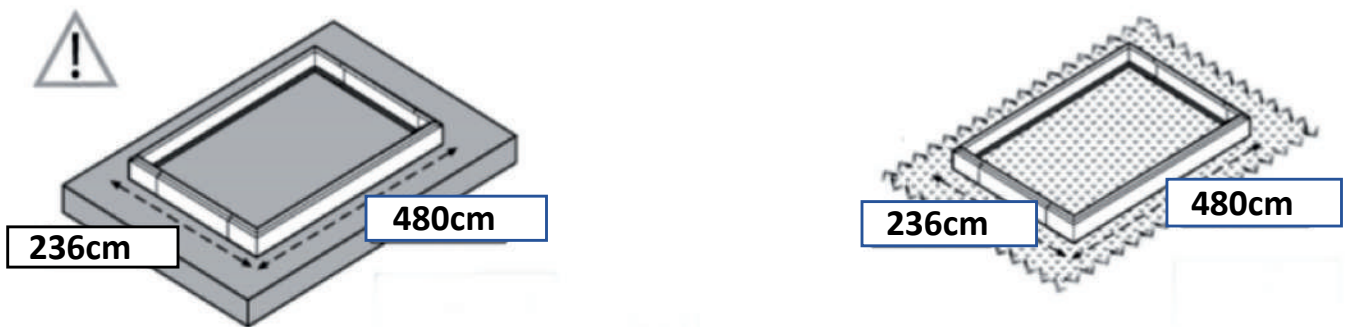
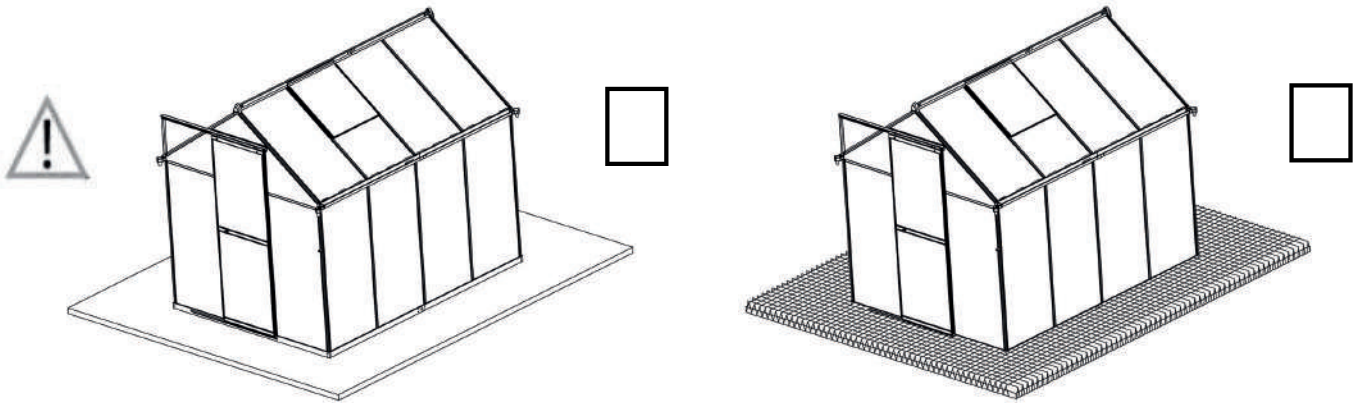

PRZED MONTAŻEM

1. Produkt musi być umieszczony i zamocowany na płaskiej, równej powierzchni. Wybierz słoneczne miejsce z dala od zwisających drzew.
2. Zdecydowanie zalecamy mocowanie tego produktu bezpośrednio do solidnego fundamentu.
3. Montaż wieloczęściowy jest lepiej realizowany przez dwie osoby. Na proces montażu należy przeznaczyć co najmniej pół dnia.
4. Wyjmij wszystkie komponenty i części z opakowań. Posortuj części i sprawdź je na liście części zawartości.
5. Części powinny być ułożone w zasięgu ręki. Trzymaj wszystkie małe części (śruby itp.) w misce, aby nie zgubić ich.
6. Należy pamiętać, że w tym przypadku używane są profile wielootworowe. W rezultacie niektóre otwory w profilach nie są wykorzystywane podczas montażu.
7. Przed rozpoczęciem należy zapoznać się z całą instrukcją. Wykonaj kroki montażu w dokładnej kolejności.
8. Jeśli przed rozpoczęciem budowy produktu wymagane jest uzyskanie odpowiednich zezwoleń, należy skontaktować się z lokalnymi władzami.

WSKAZÓWKI DOTYCZĄCE BEZPIECZEŃSTWA

Zdecydowanie zalecamy używanie rękawic roboczych podczas montażu. Zawsze zakładaj buty i okulary ochronne podczas pracy z wytłaczanym aluminium. Nie próbuj montować szklarni aluminiowej w wietrznych lub mokrych warunkach. Szklarnia aluminiowa musi być ustawiona i zamocowana na płaskiej, równej powierzchni. Przed wbiciem kołków upewnij się, że w ziemi nie ma ukrytych rur ani kabli. Nie ustawiaj szklarni aluminiowej w miejscu narażonym na silny wiatr. Nie opieraj się o szklarnię aluminiową ani jej nie popychaj podczas montażu. Nie dotykaj napowietrznych przewodów zasilających aluminiowymi profilami. Trzymaj dzieci z dala od miejsca montażu. Nie próbuj montować szklarni aluminiowej, jeśli jesteś zmęczony, zażyłeś narkotyki lub alkohol lub masz skłonność do zawrotów głowy. Zutilizuj wszystkie plastikowe torby w bezpieczny sposób i trzymaj je poza zasięgiem dzieci. Jeśli używasz drabiny lub elektronarzędzi, upewnij się, że postępujesz zgodnie z zaleceniami producenta dotyczącymi bezpieczeństwa. Gorące przedmioty, takie jak niedawno używane grille, palniki itp., nie mogą być przechowywane w szopie ściennej.

PORADY OGÓLNE

Jest to montaż składający się z wielu części, należy przeznaczyć na montaż co najmniej 3-4 godziny. Wybierając miejsce, wybierz nasłonecznione, równe miejsce z dala od zwisających drzew i dobrze chronione przed wiatrem. Jeśli mocujesz szklarnię aluminiową bezpośrednio do solidnego fundamentu betonowego, użyj wstępnie wywierconych otworów w dostarczonej metalowej podstawie. Części składowe należy sprawdzić i rozłożyć w pobliżu. Trzymaj wszystkie małe części (śruby itp.) w misce, aby się nie zgubiły. Utrzymuj dach wolny od śniegu i liści.

PLATFORMA

Sprzęt ochronny

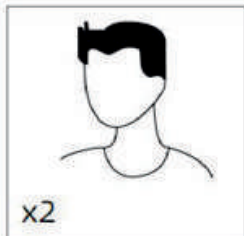

Potrzebne 2 osoby

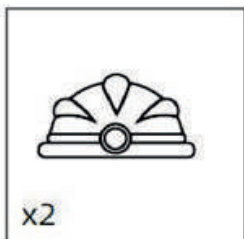

Kask bezpieczeństwa



Rękawice



Okulary ochronne

Narzędzia pomiarowe i sprzęt instalacyjny



Taśma miernicza



Klucz C10



Reguła kątowna



Śrubokręt krzyżakowy



Drabina trójkątna



Marker



Knypel

Uwagi:

Usuń około 5 cm folii ze wszystkich krawędzi arkusza przed montażem. Usuń całą folię natychmiast po zakończeniu budowy.

PANEL POLIWĘGLANOWY

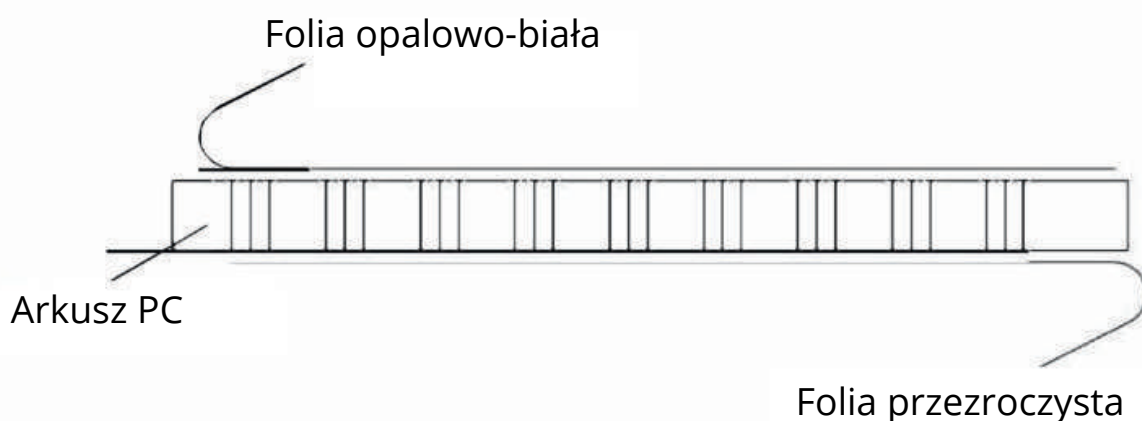





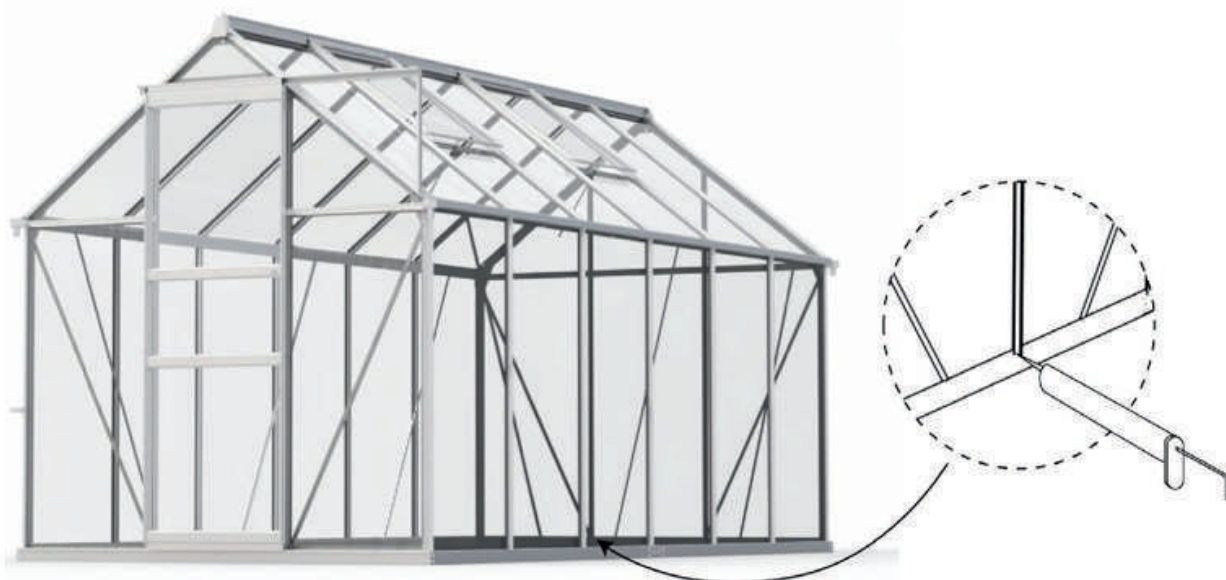

















Rada



















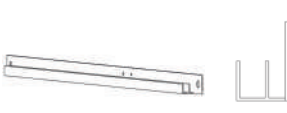

Nie jest to konieczne, ale radzimy: Aby zapewnić dodatkową wytrzymałość, możesz także kupić trochę kleju lub taśmy pomiędzy panelem poliwęglanowym a aluminiową ramą w celu zwiększenia stabilności.

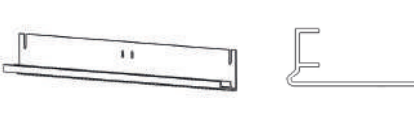







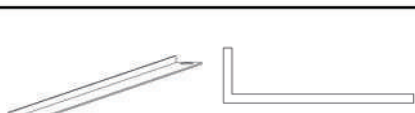
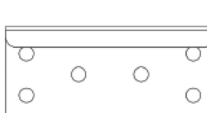



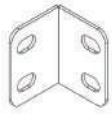

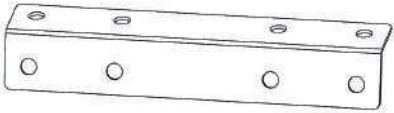

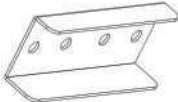



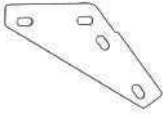

Lista komponentów

KOD		ILOŚĆ	KOD		ILOŚĆ
A1		4	A9		1
A2R		1	A10		1
A2L		1	A11		4
A3L		1	A12		1
A3R		1	A13		1
A4		14	A14		2
A5L		1	A15L		1
A5R		1	A15R		1
A6		14	A16		1
A7		2	A17		2
A8		2	A18		2



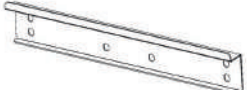
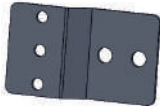
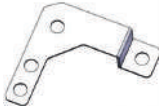

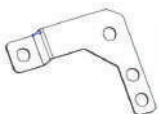

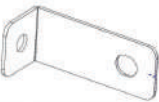
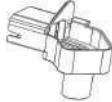



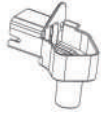









Lista komponentów

KOD		ILOŚĆ	KOD		ILOŚĆ
A19		2	A29		2
A20		2	A30		4
A21L		4	A31		1
A21R		4	A32		1
A22		4	23S1		1
A23		4	23S2		1
A24		4	23N1		1
A25		2	23N2		1
A26		2	23E1		2
A27		4	23E2		2
A28		8	C1		3

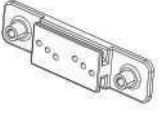
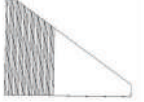
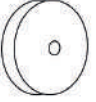







Lista komponentów

KOD		ILOŚĆ	KOD		ILOŚĆ
C2		4	C13L		2
C3		1	C13R		2
C4		2	C14		5
C5		3	C15		10
C6		6	C16		4
C7		4	C17		2
C8		2	C18		2
C9		2	C19		4
C10		1	C20		8
C11L		1	C21		38
C11R		1	R1		2
C12		4	R2		2

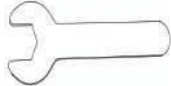
Lista komponentów

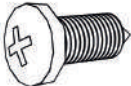
KOD		ILOŚĆ	KOD		ILOŚĆ
R3		2	P8		4
R4		4	P9		4
R5		4	P10		4
R6		4	P11		4
P1		2	B1		8
P2		16	B2		8
P3		12	B4		2
P4		2	S1		4
P5		2	S2		8
P6		2	F1	 	24
P7		2	F2		8

Lista komponentów

KOD		ILOŚĆ	KOD		ILOŚĆ
F3		12	F9		6
F4		310	F10		2
F5		310	F11		6
F6		36	F12		4
F7		34	EVA		18m
F8		12			

Uwaga:

Wszystkie śruby nie są dokręcane najpierw, aby ułatwić regulację. Należy je dokręcić na ostatnim etapie.

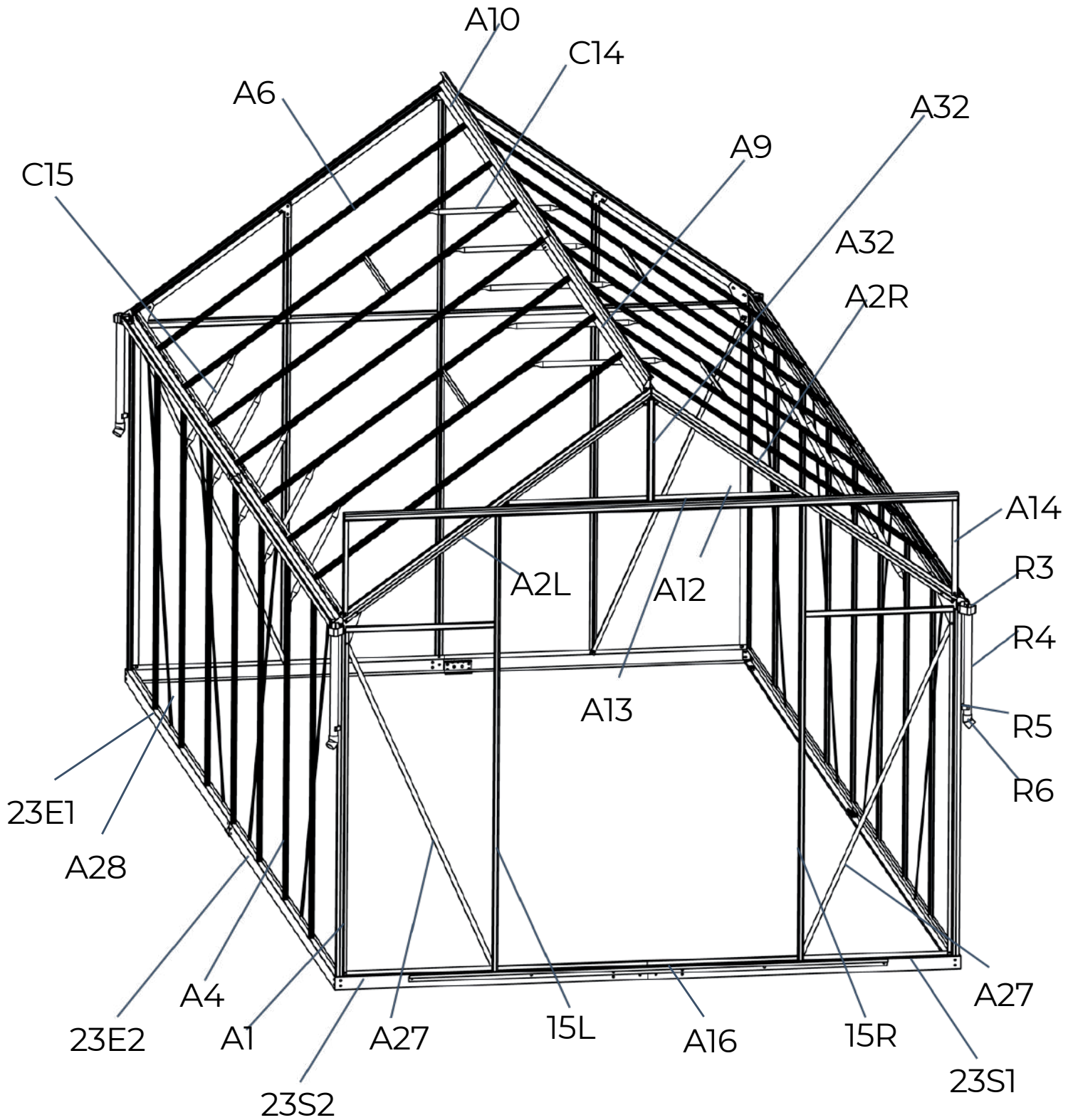

Przód

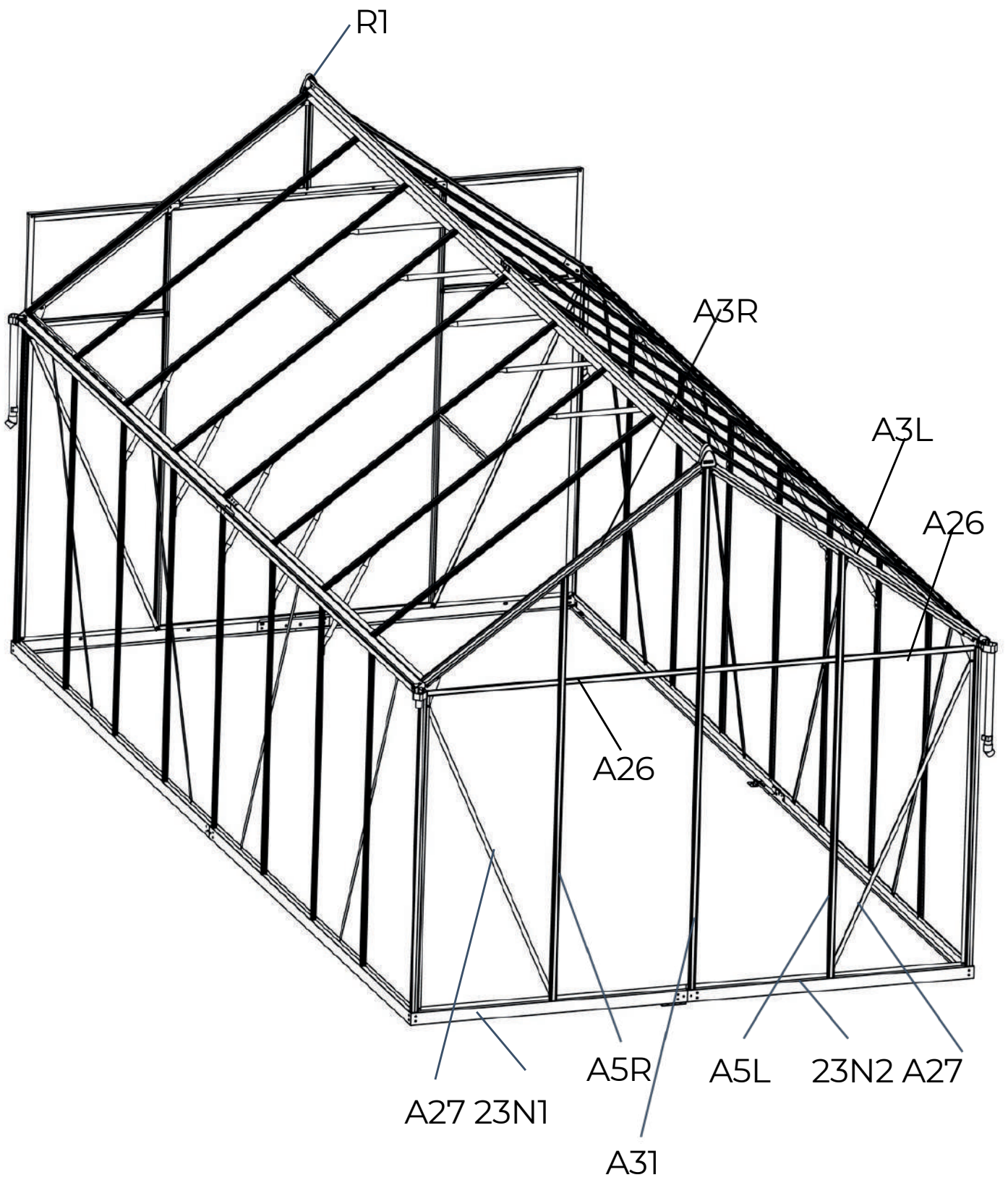

Tył

1

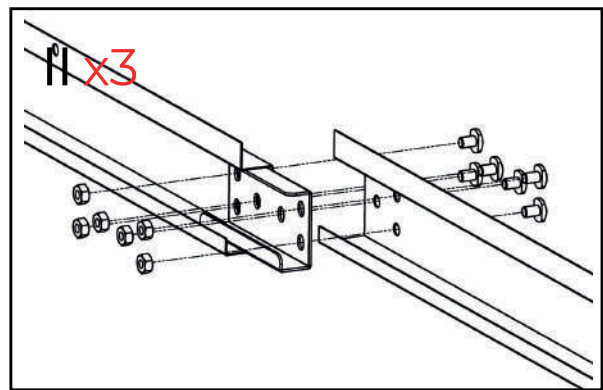
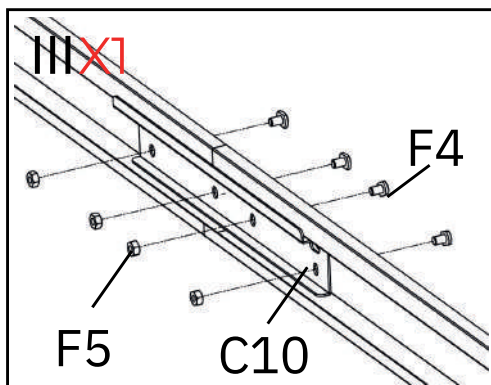
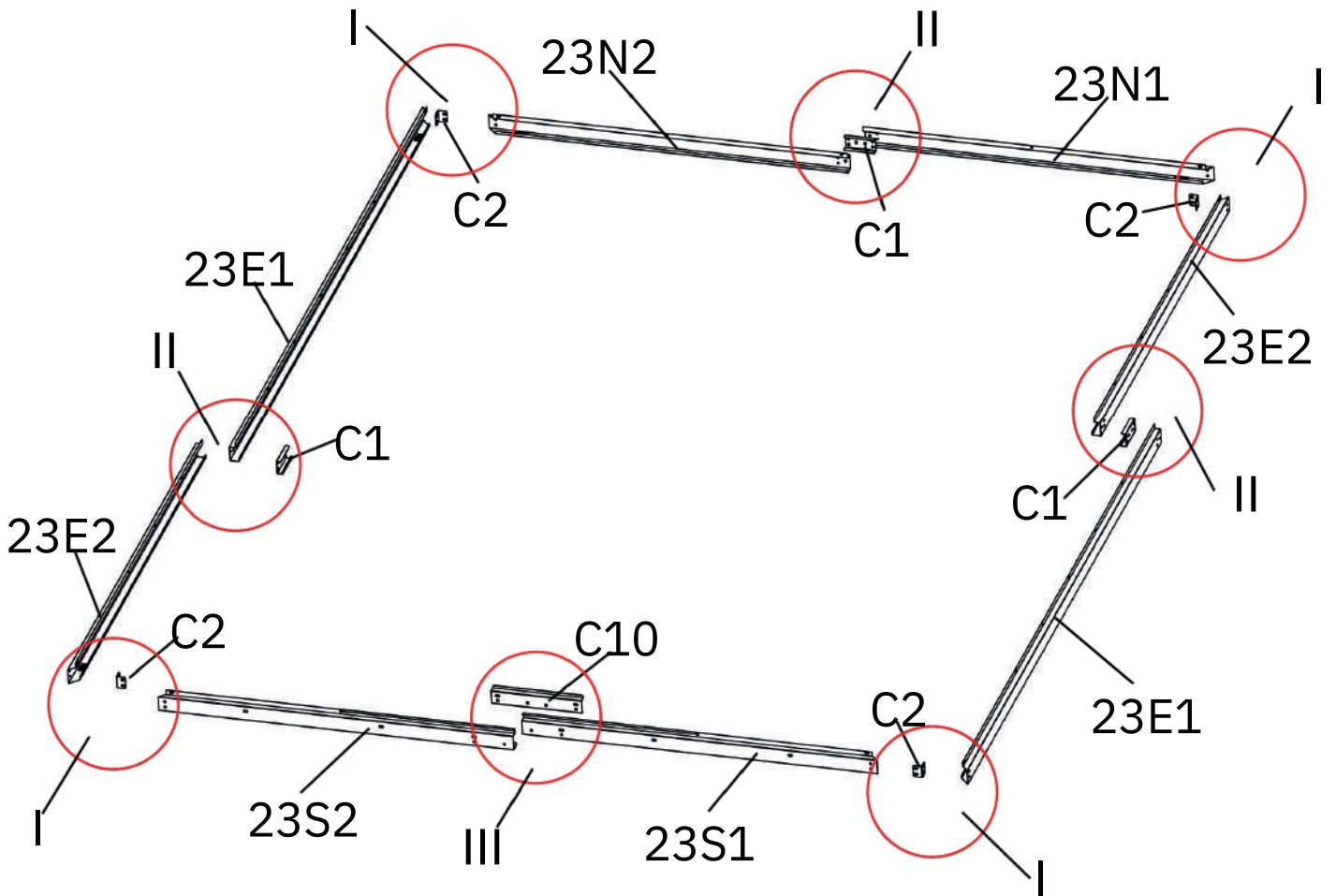
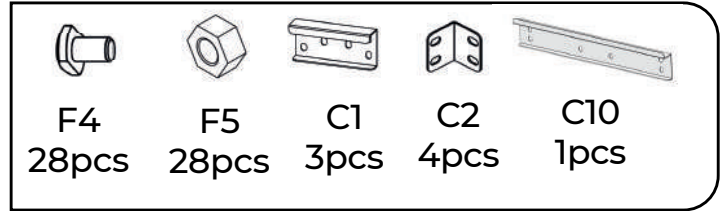
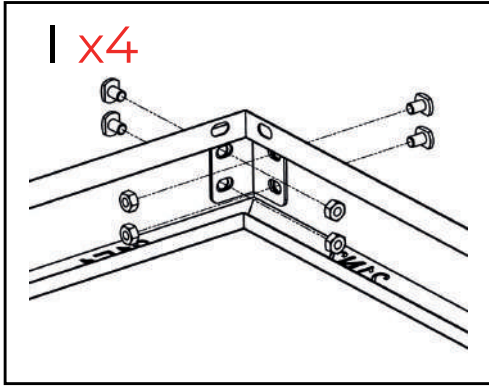
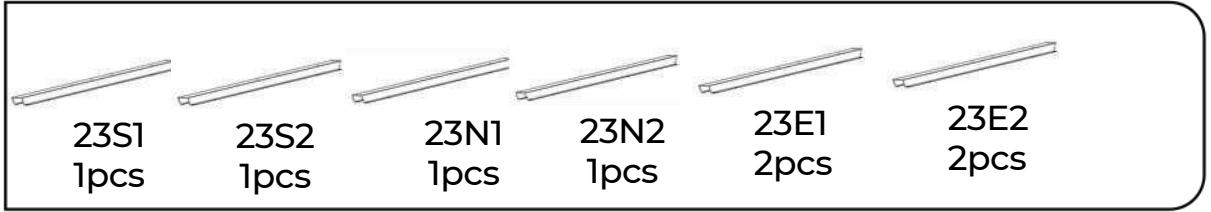

2



A16
1pcs



F4
6pcs



F5
6pcs

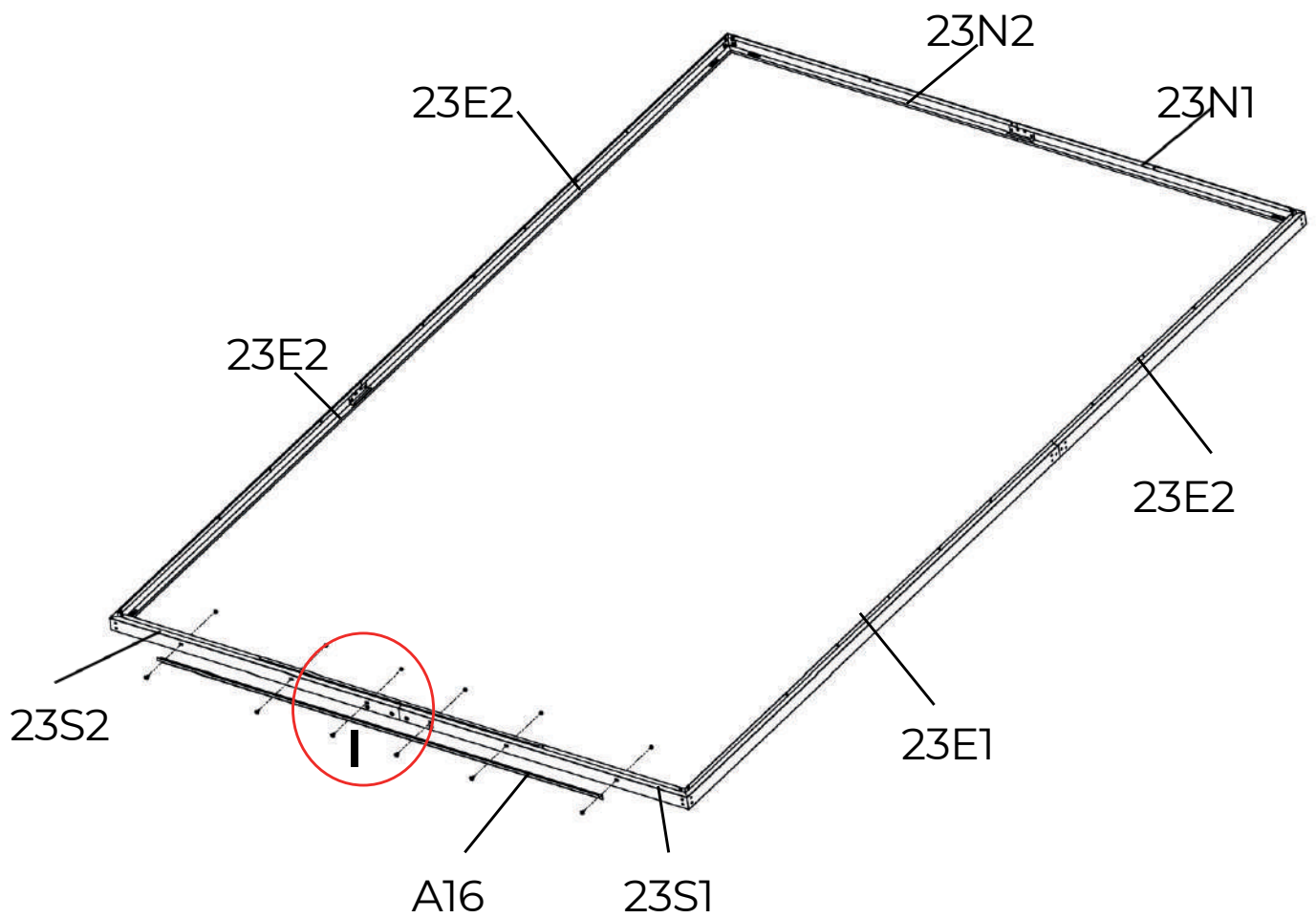
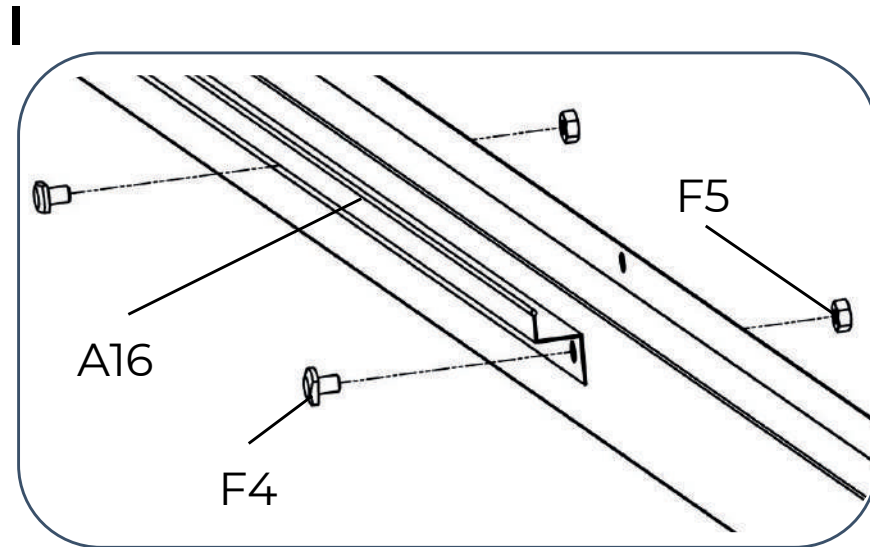

3



A1
4pcs



F4
8pcs



F5
8pcs

Uwaga: Podczas montażu A1, koniec z dwoma otworami powinien znajdować się na górze.

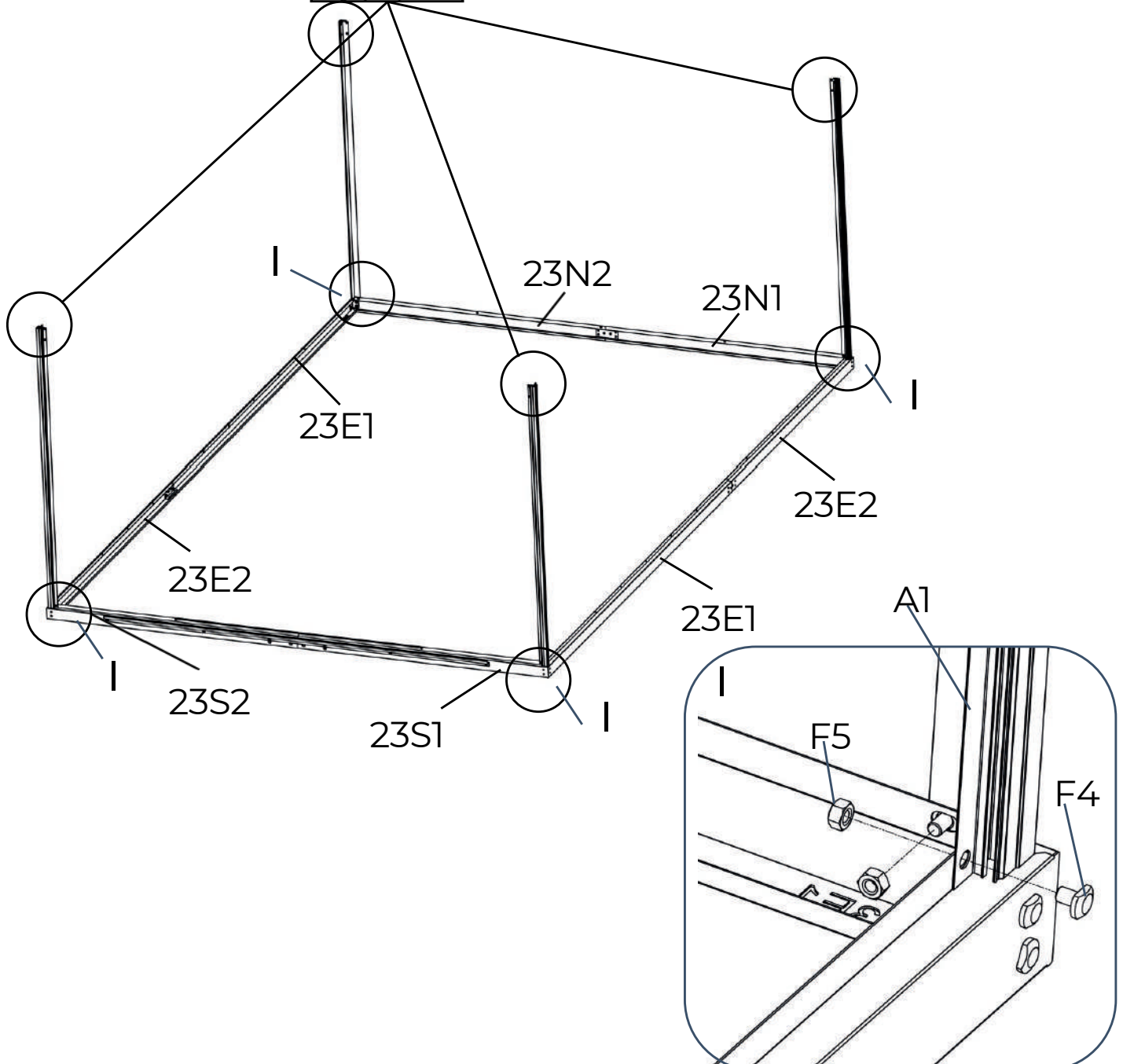
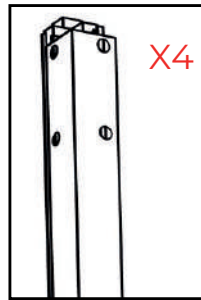

4



A5L
1pcs



F4
3pcs



F5
3pcs



A5R
1pcs



A31
1pcs

Tył

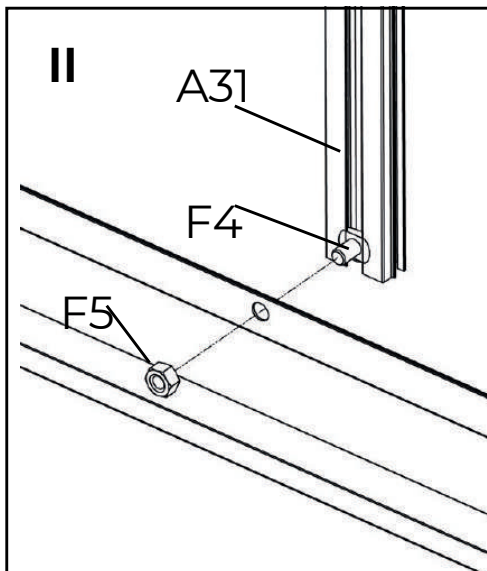
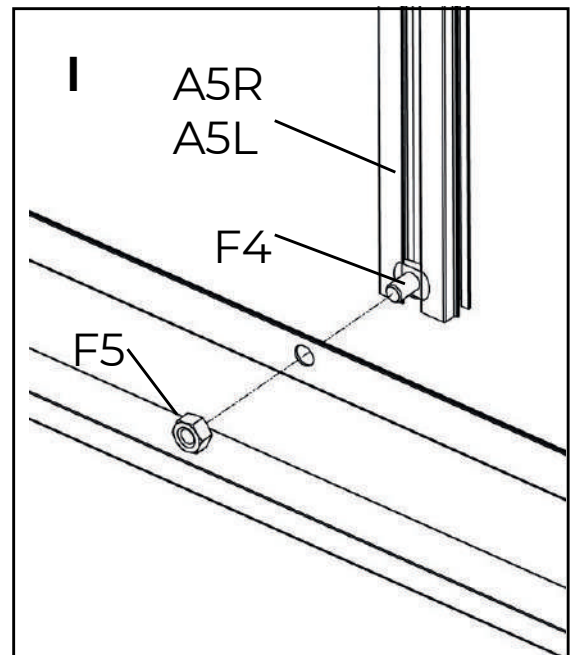
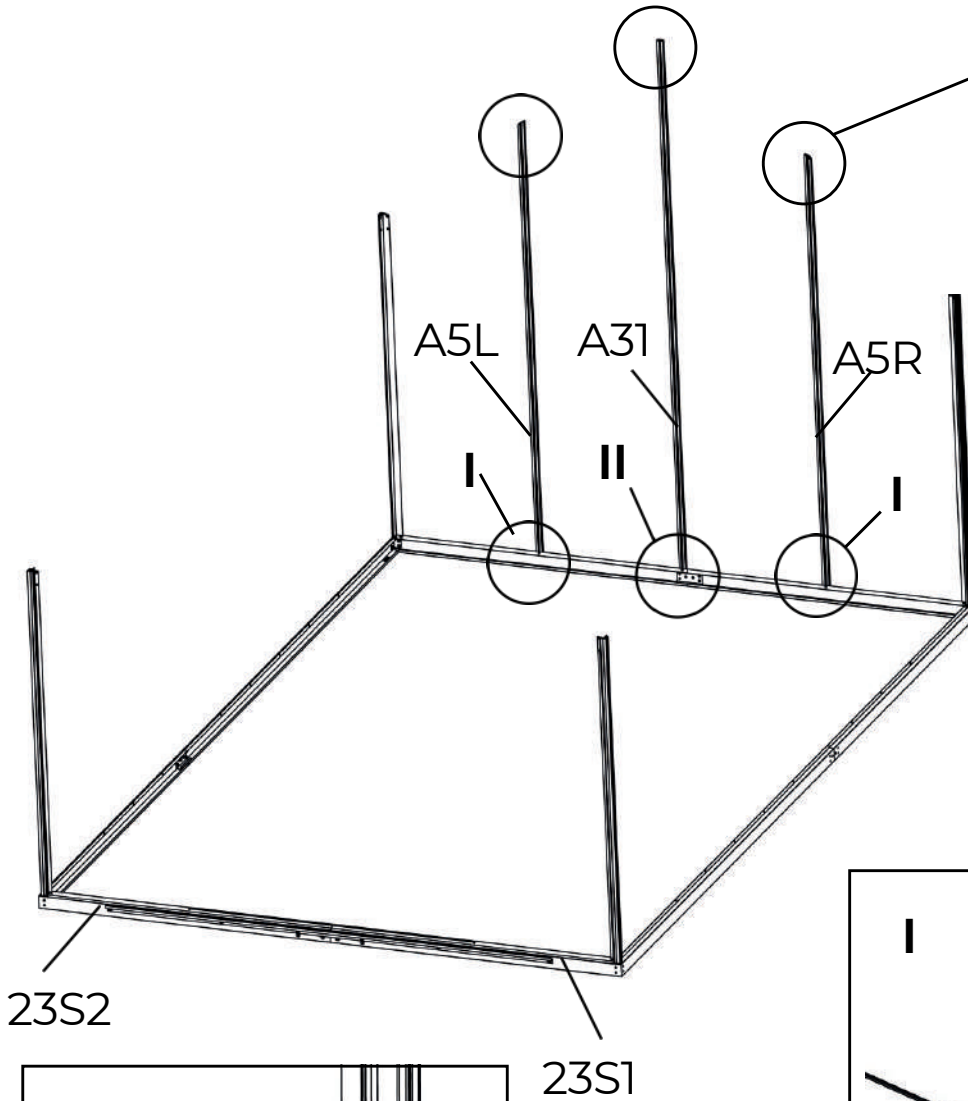
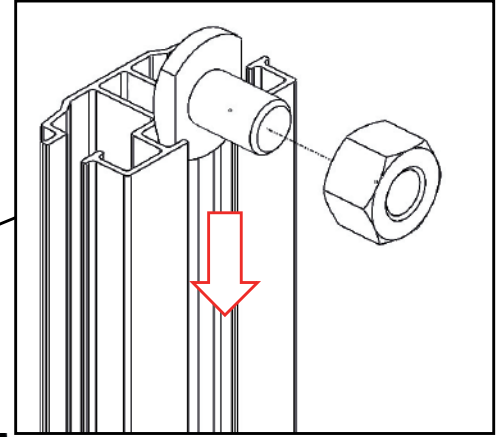

5

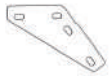

C7
2pcs



A26
2pcs



A27
2pcs



F4
9pcs



F5
9pcs

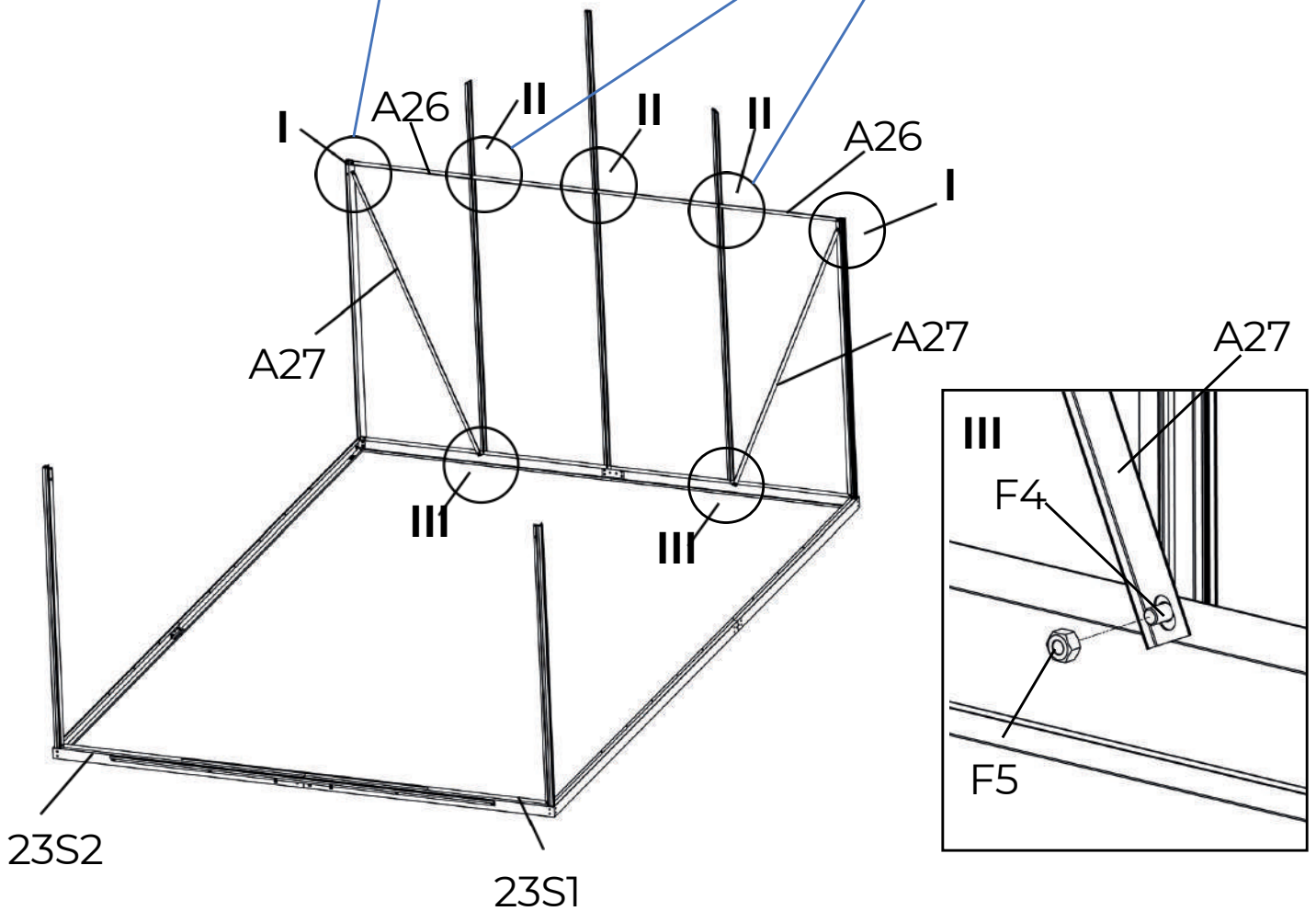
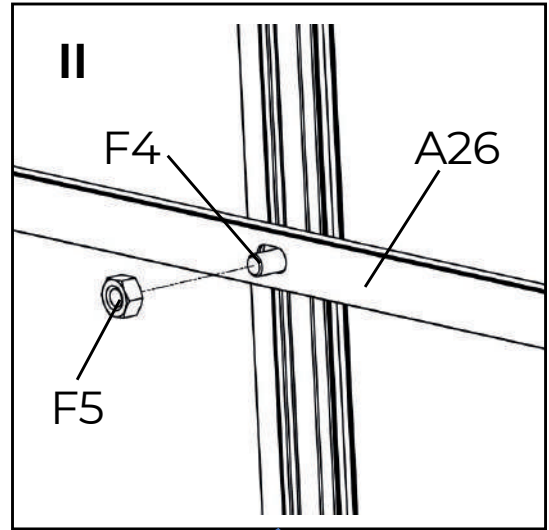
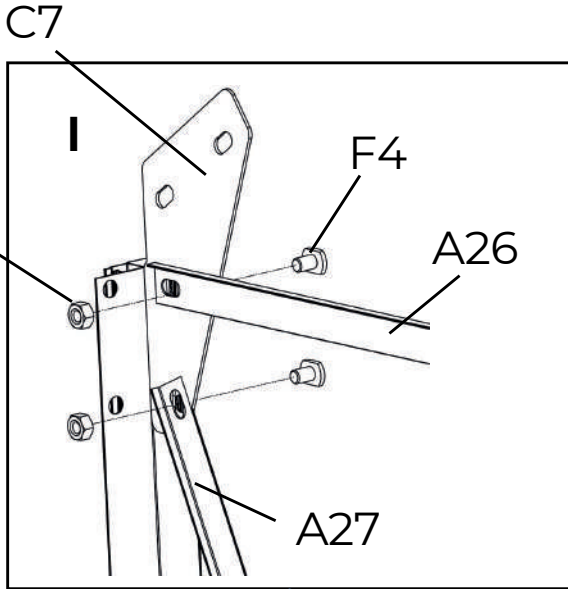

6

P11
4pcs

C21
4pcs

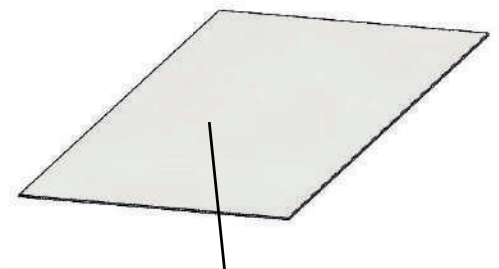
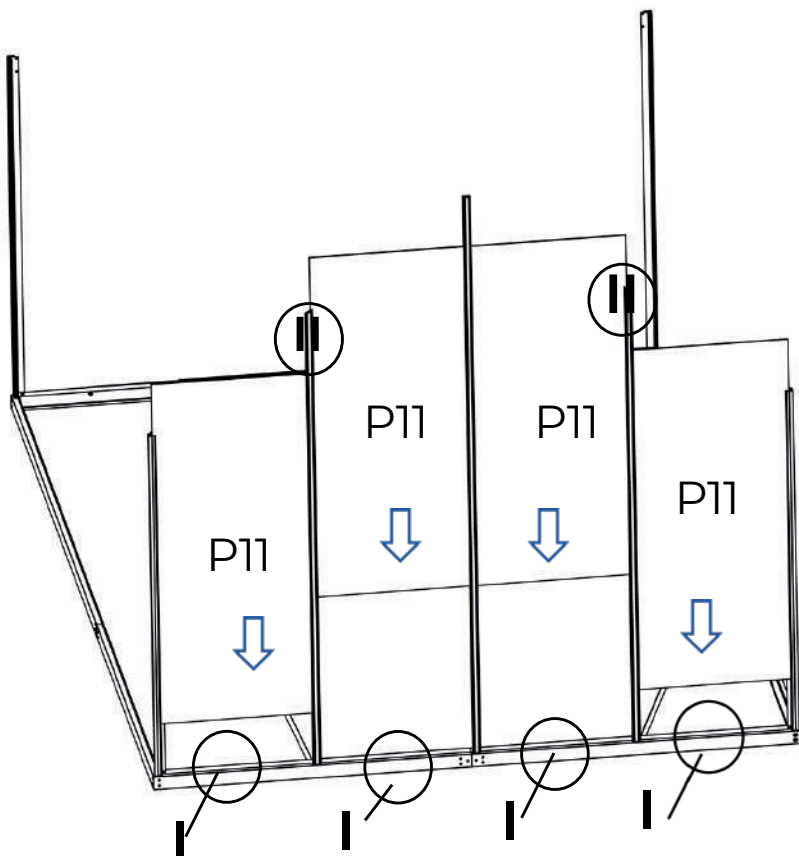
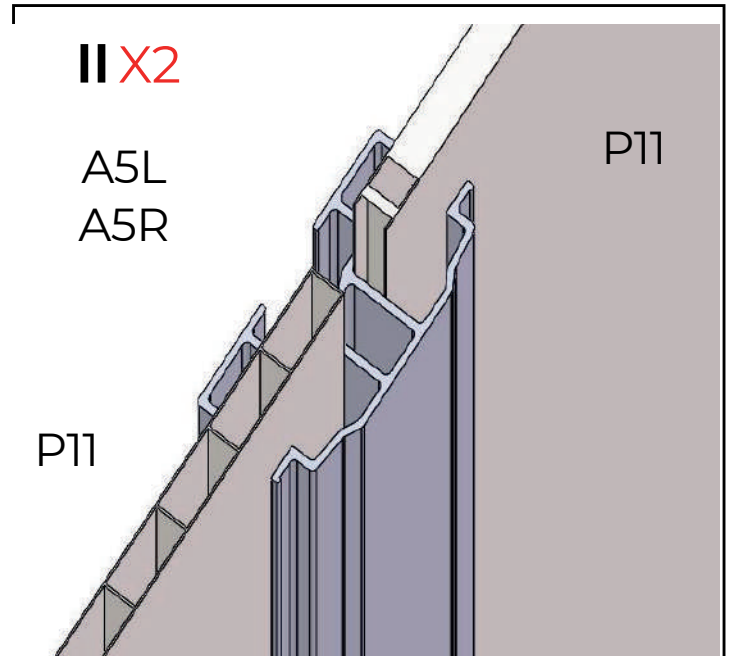
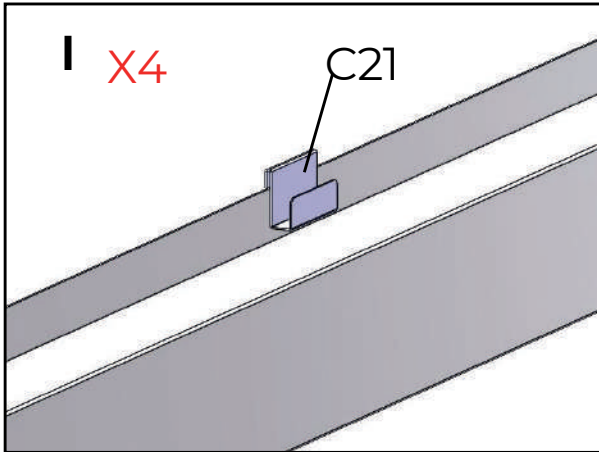





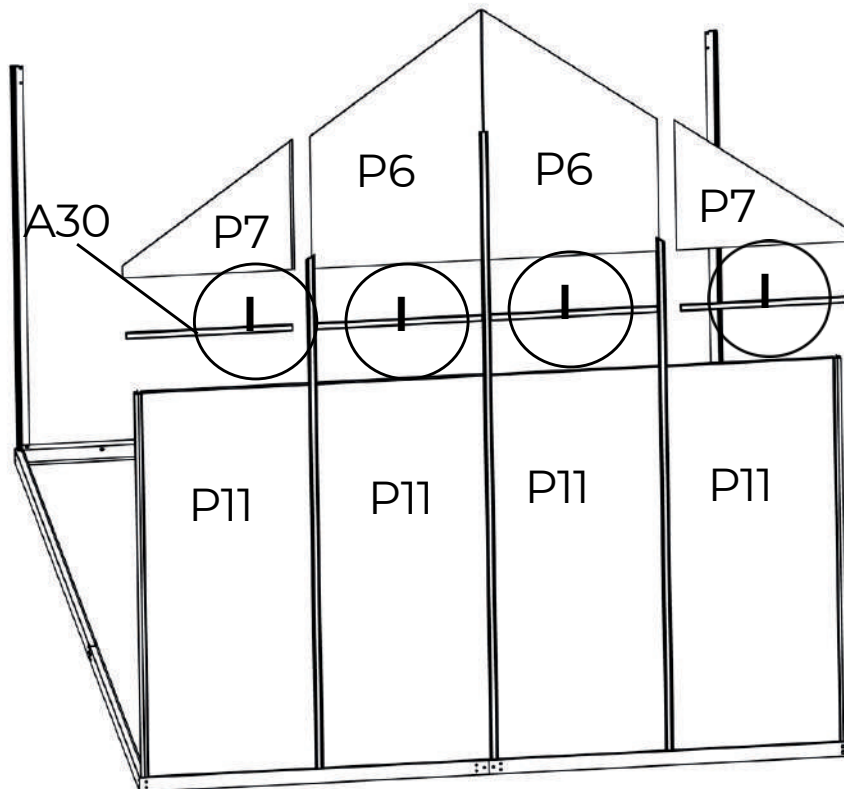
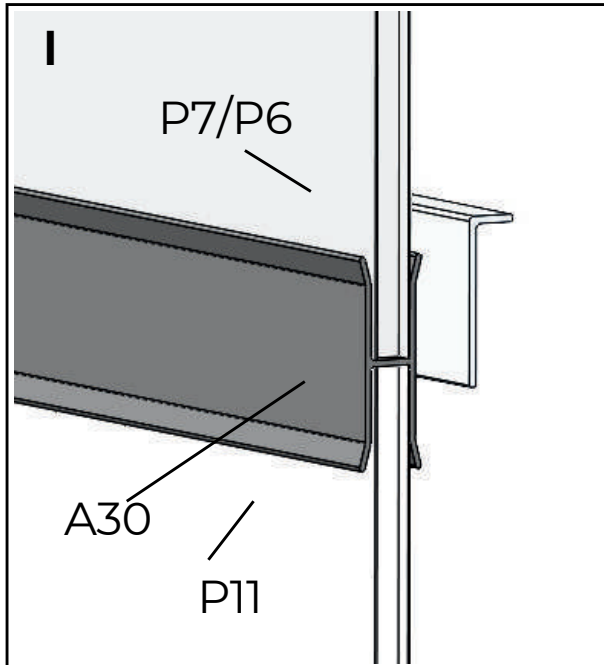
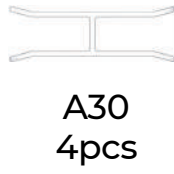
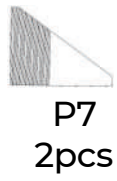

Przed montażem należy zdjąć folię ochronną.

7



8

					
A3L 1pcs	A3R 1pcs	F4 13pcs	F5 13pcs	C8 1pcs	C9 2pcs

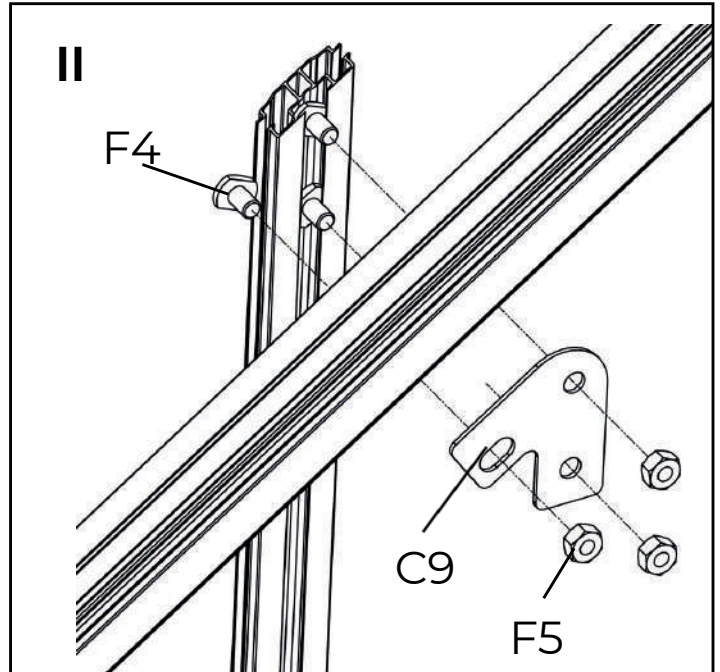
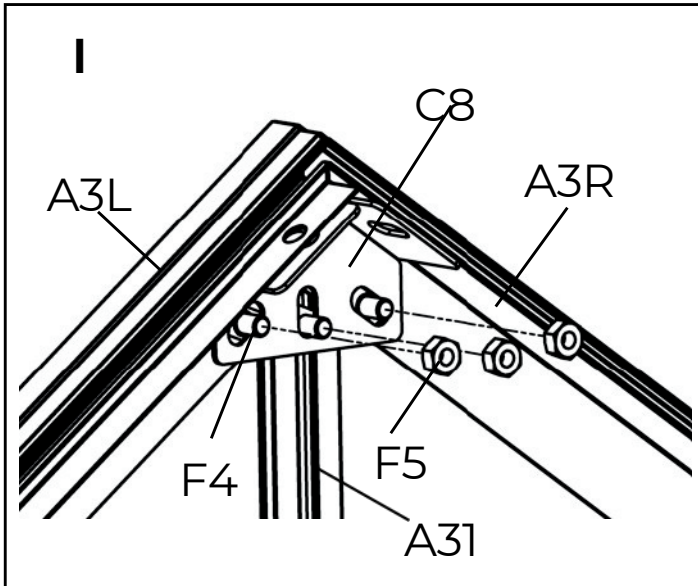

Uwaga: Najpierw podłącz A3R i A3L do C8, a następnie do A31.

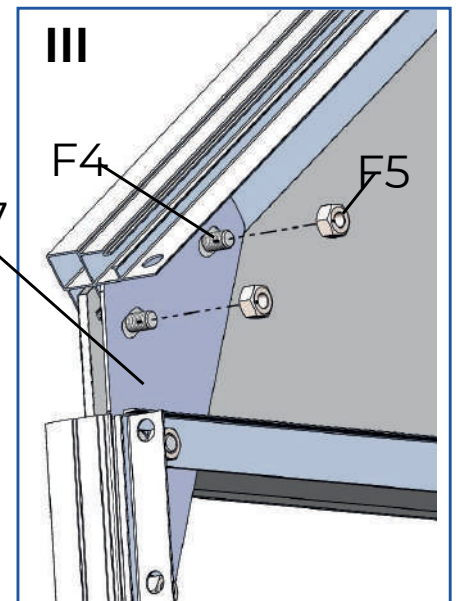
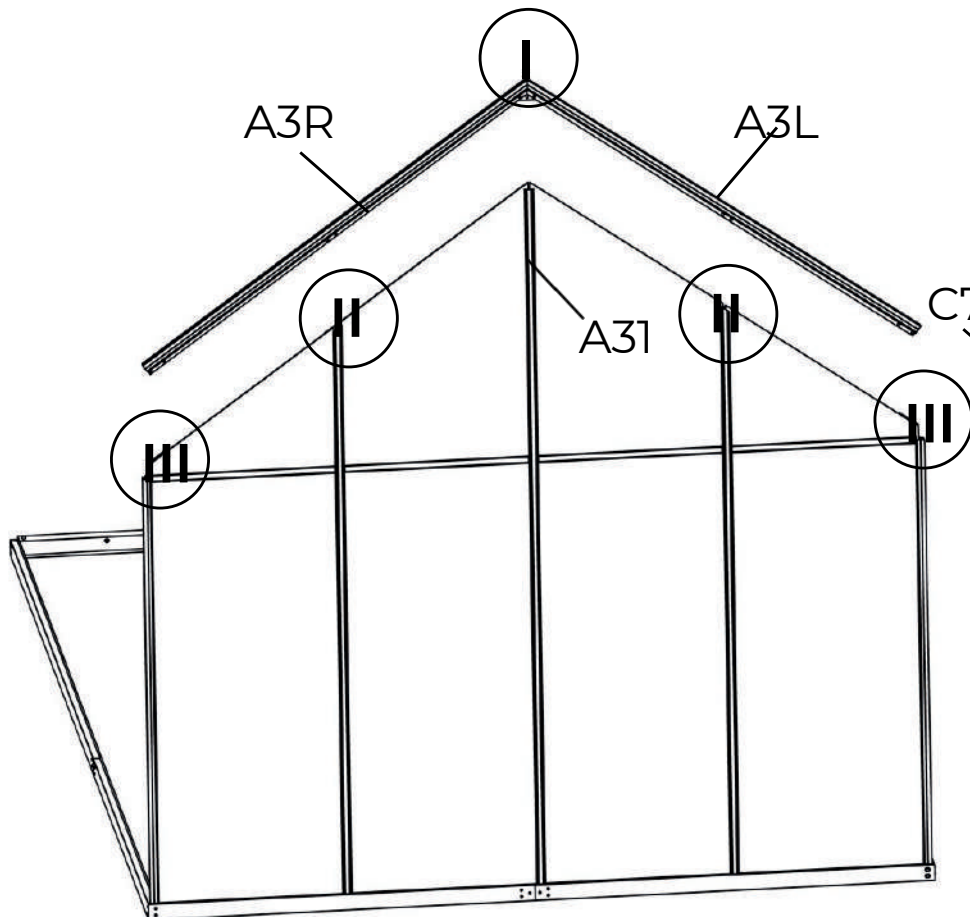

9

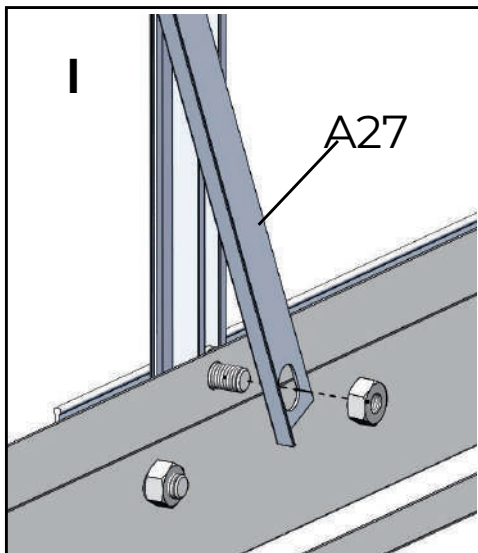
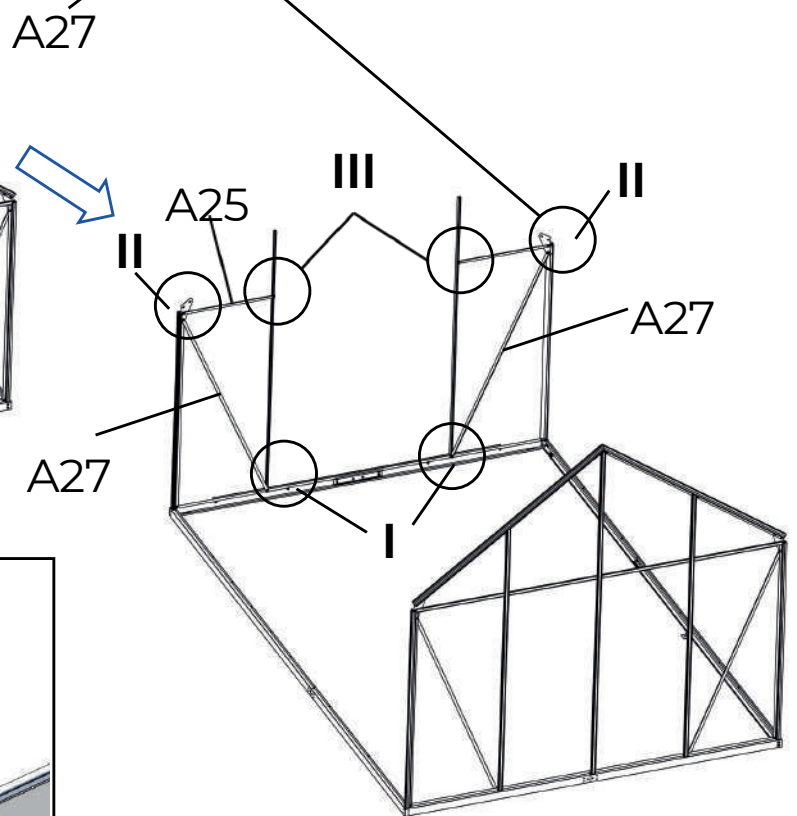
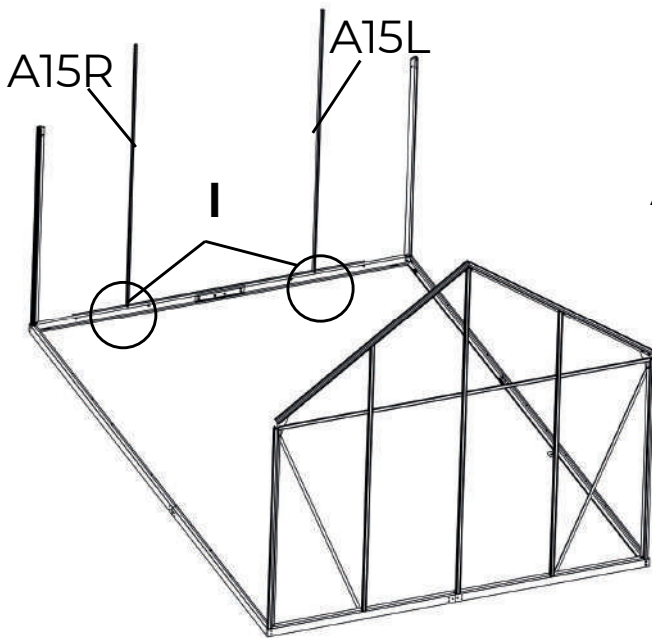
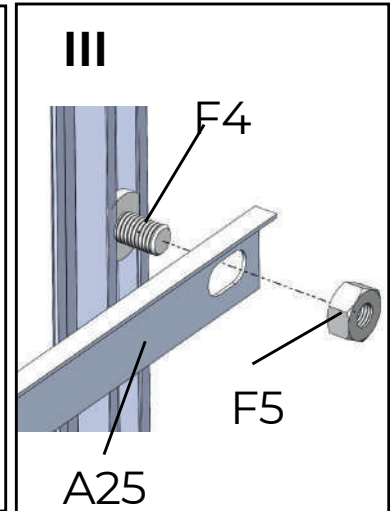
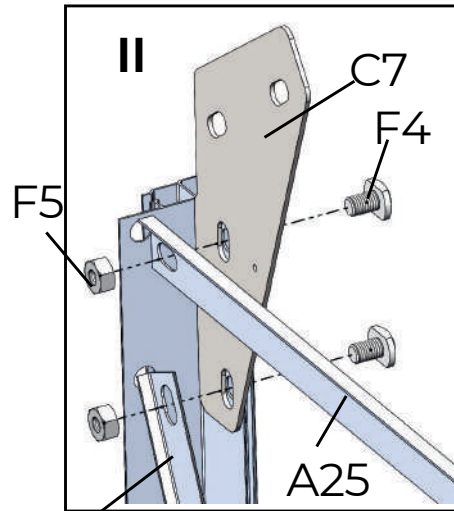
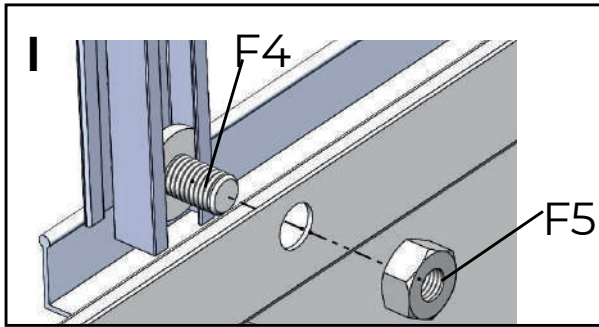
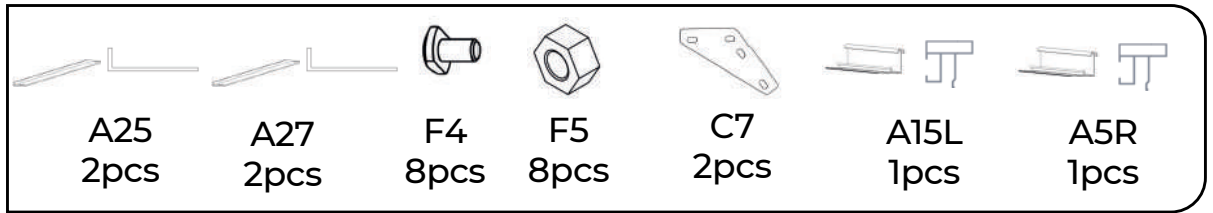

10

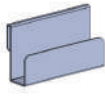

C21
2pcs



P1
2pcs

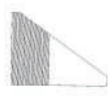

P5
2pcs



A29
2pcs

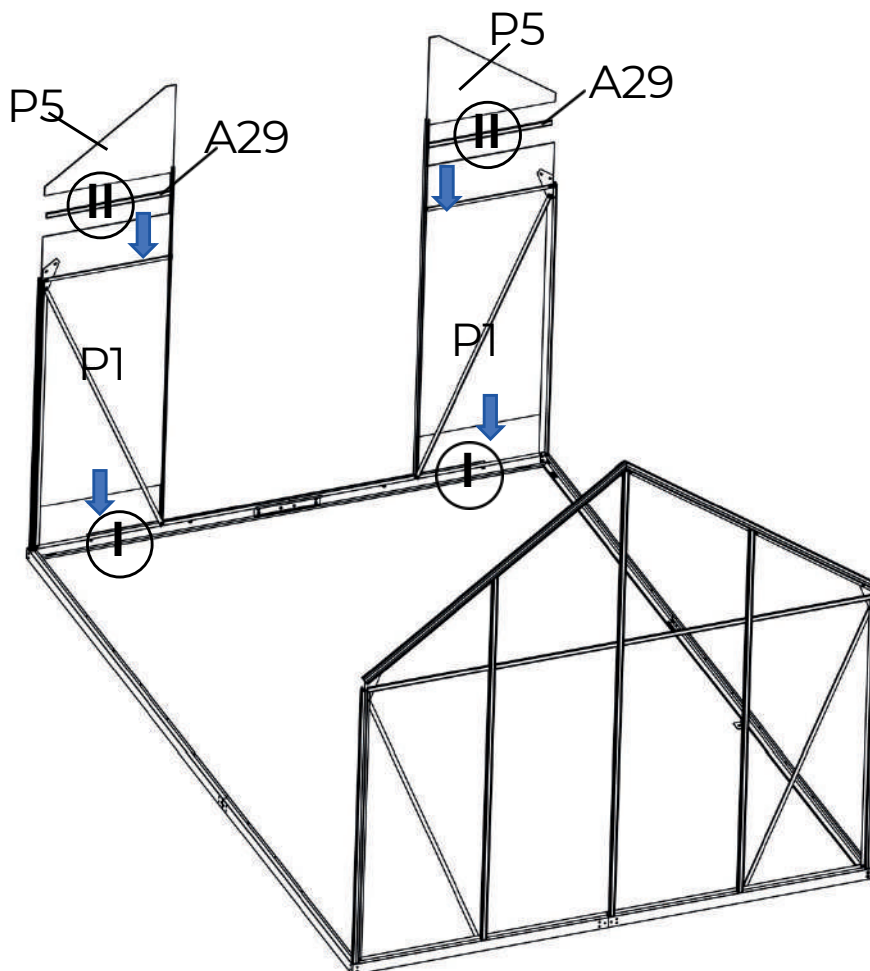
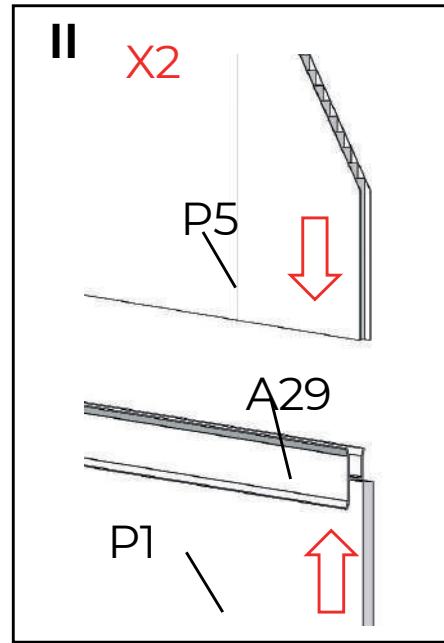
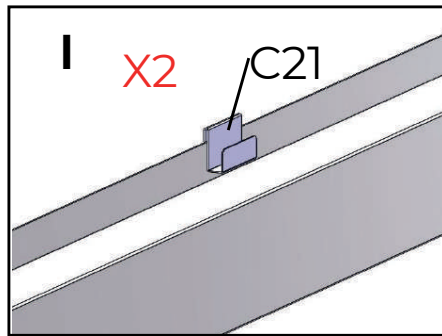

11



C11L
1pcs

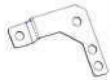

C11R
1pcs



A12
1pcs



F4
7pcs



F5
7pcs



A32
1pcs

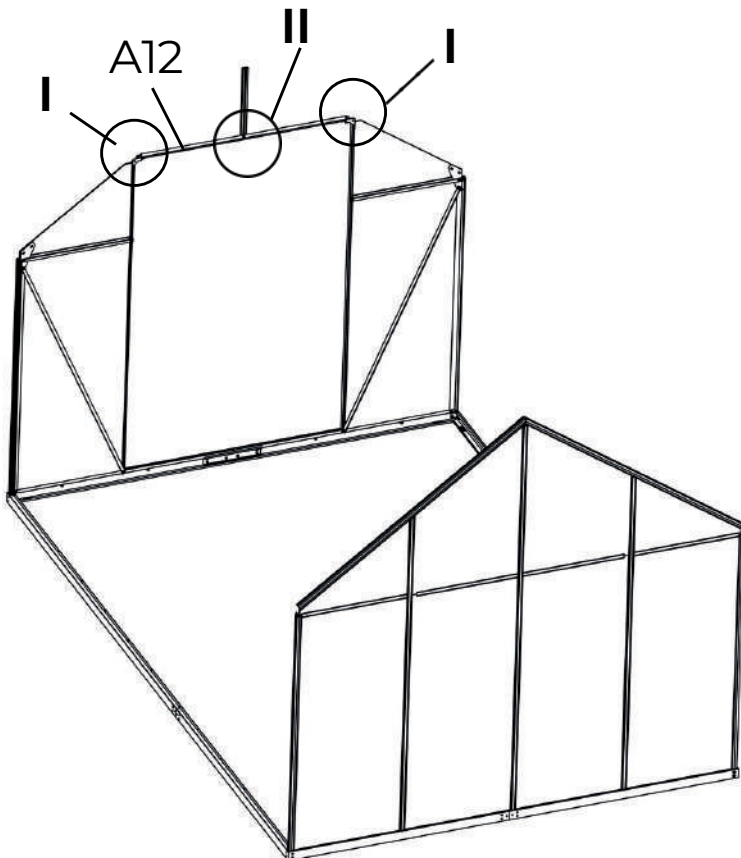
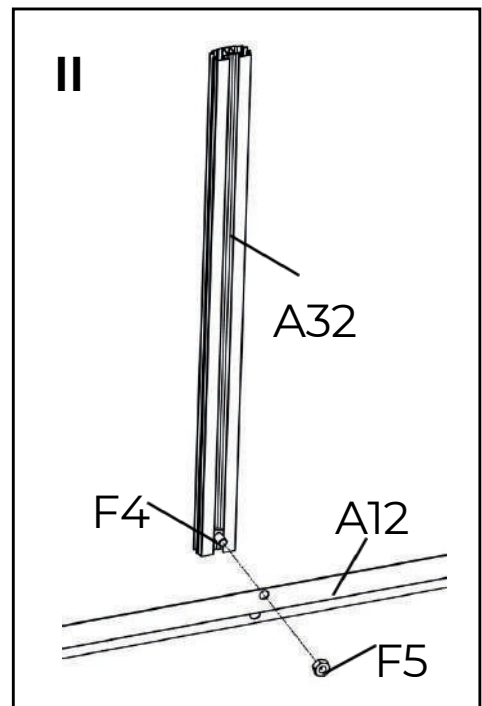
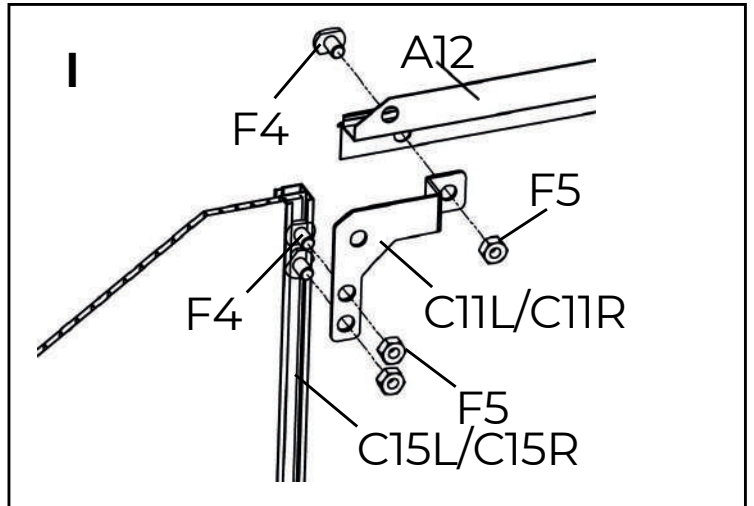
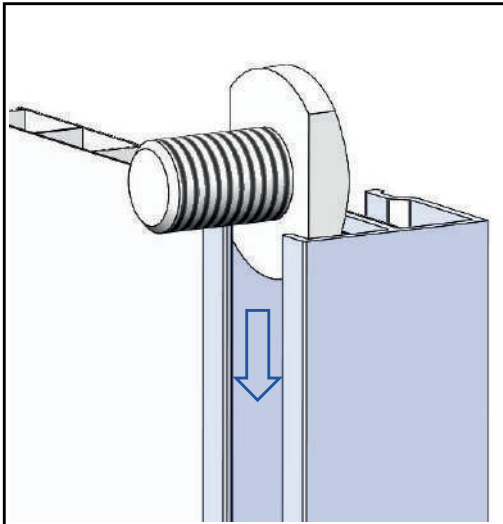

12

					
A2L 1pcs	A2R 1pcs	C8 1pcs	F4 11pcs	F5 11pcs	P4 2pcs

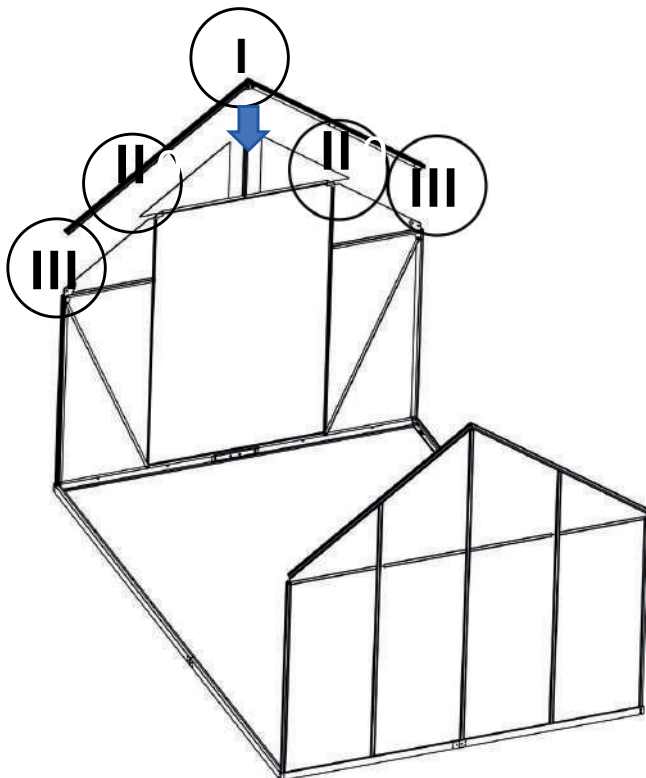
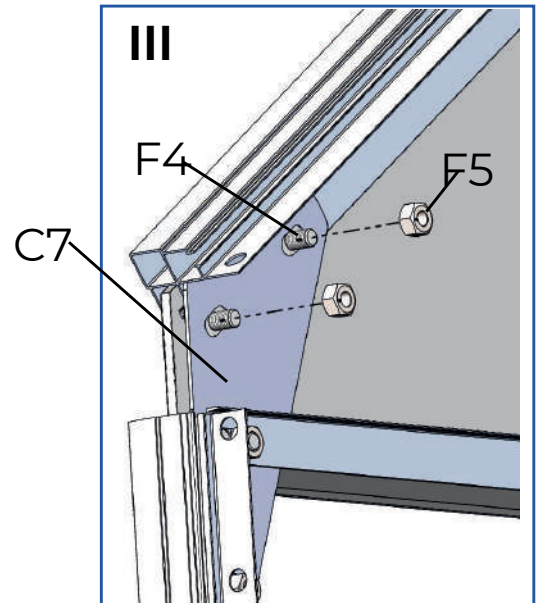
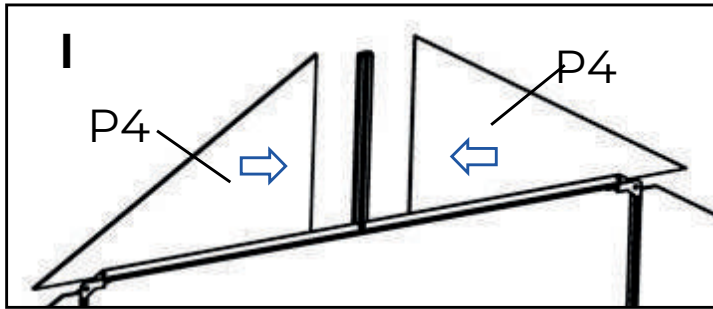
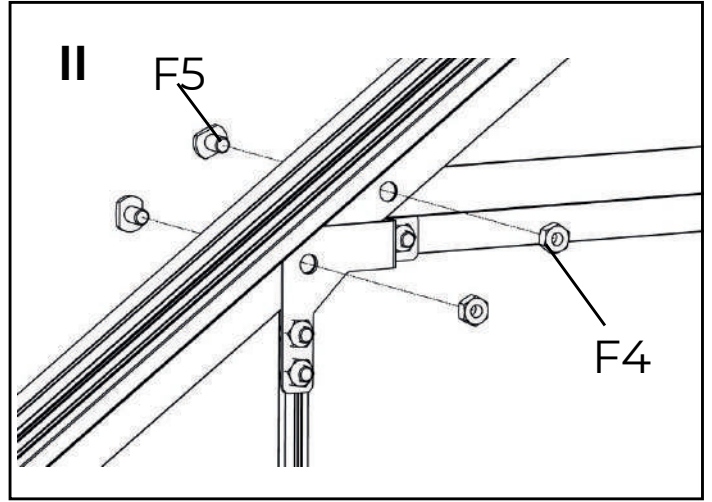
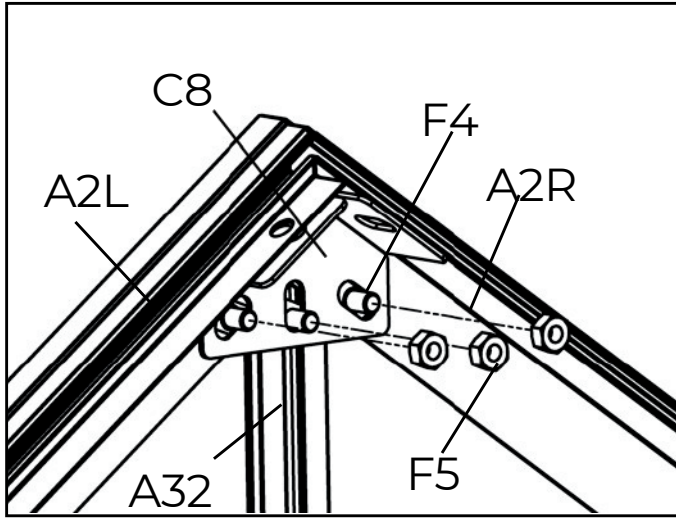

13

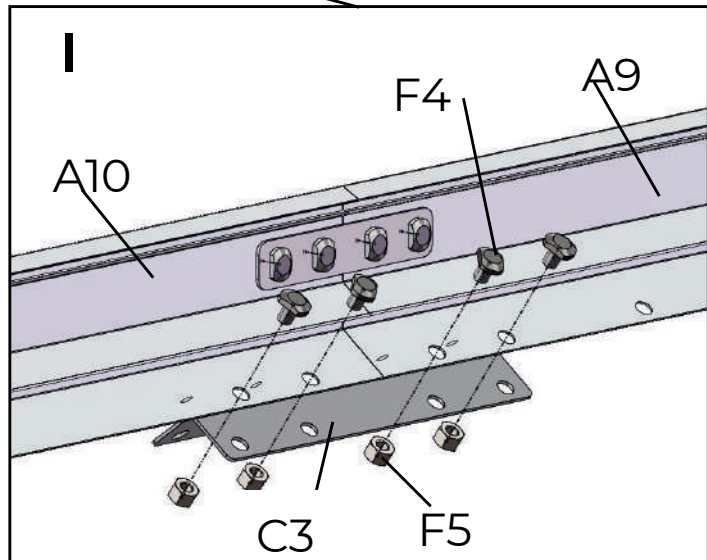
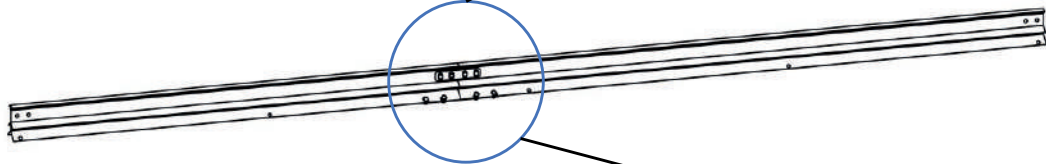
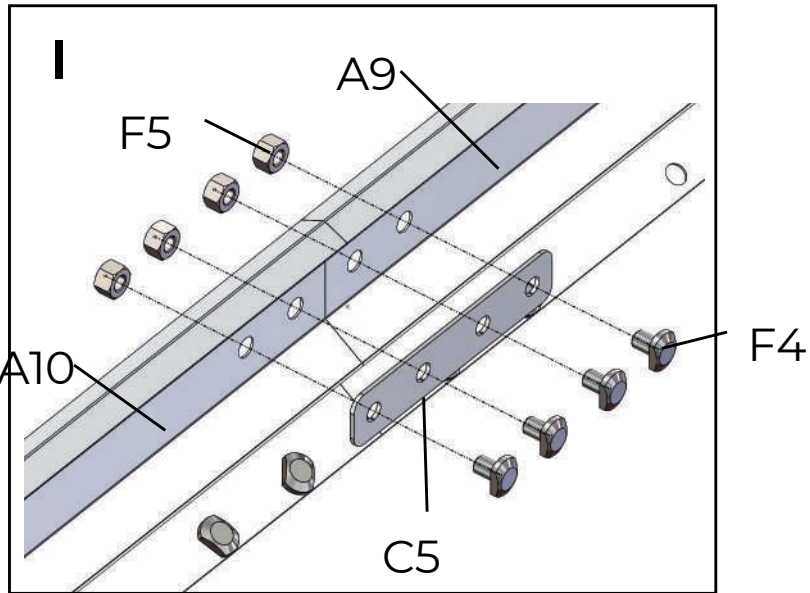
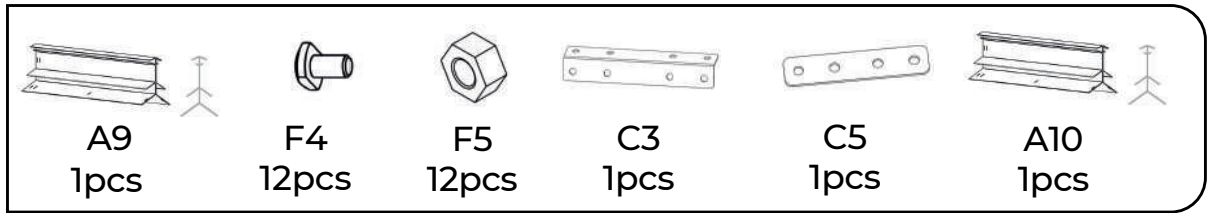

14



F4
4pcs



F5
4pcs

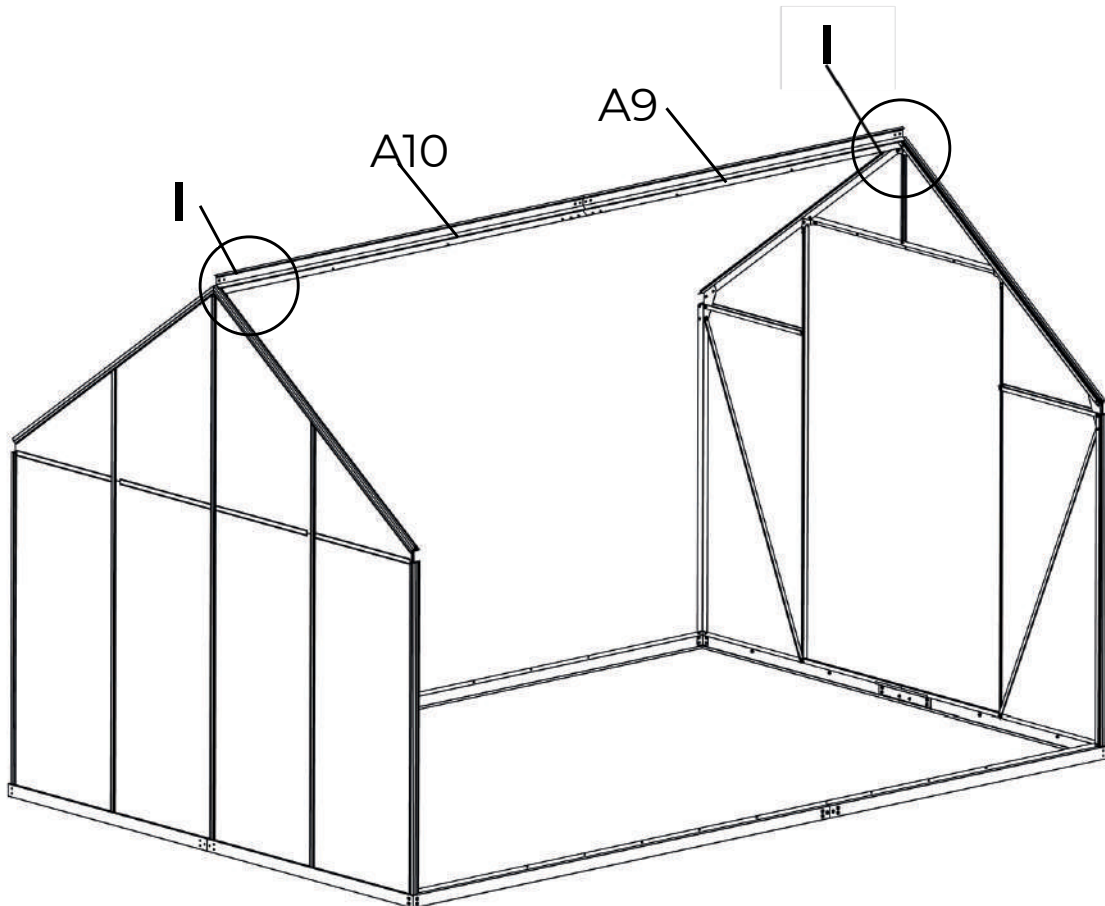
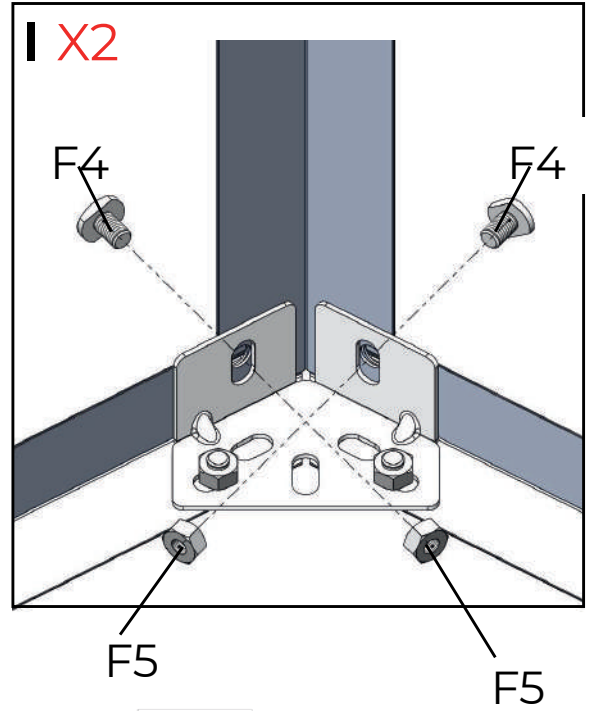
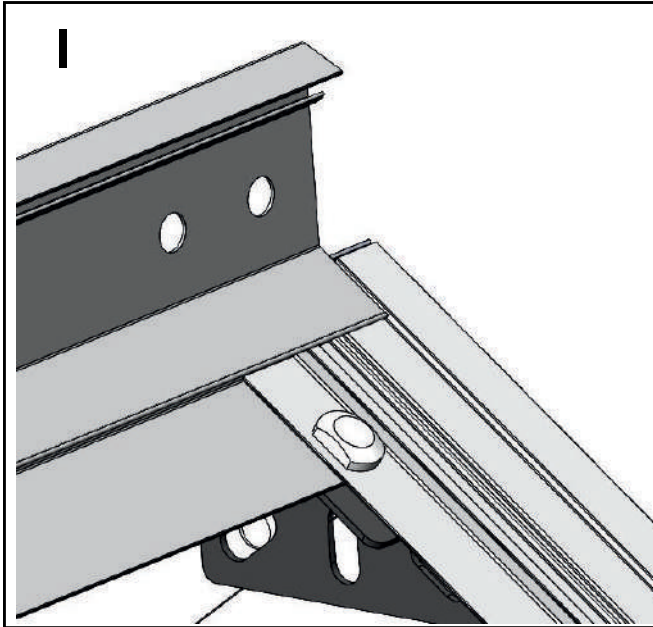

15

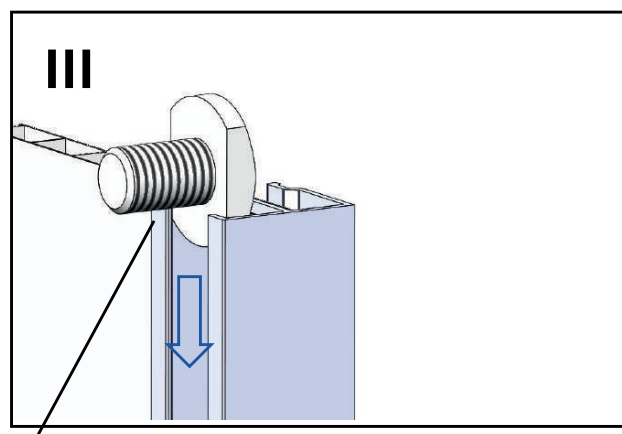
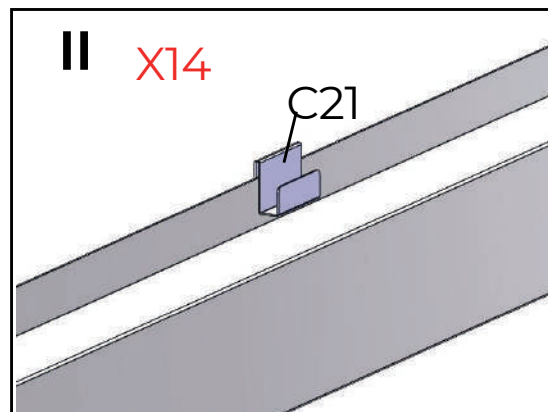
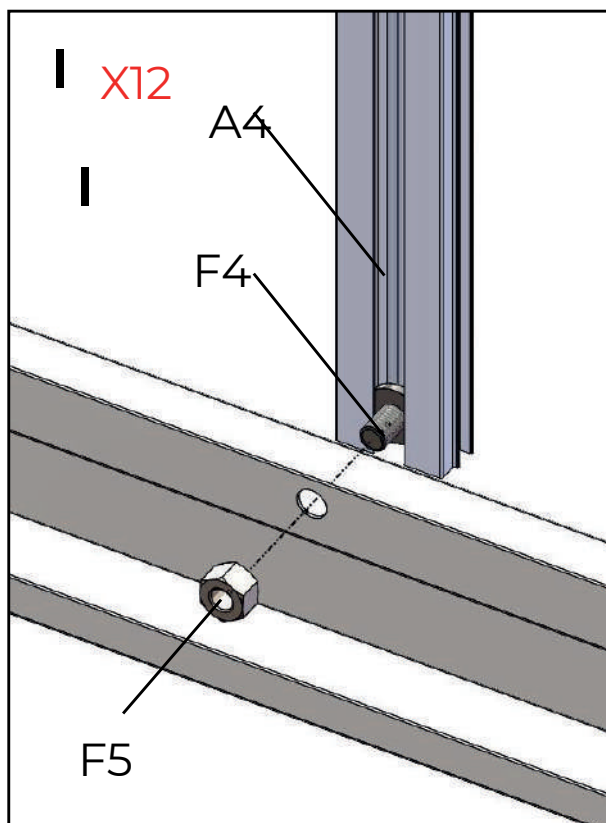
F4
24pcsF5
14pcsA4
14pcsC21
16PCS

Uwaga: Zamontuj wstępnie jeden moduł F4 w formacie A4, aby później móc zainstalować moduł C15.

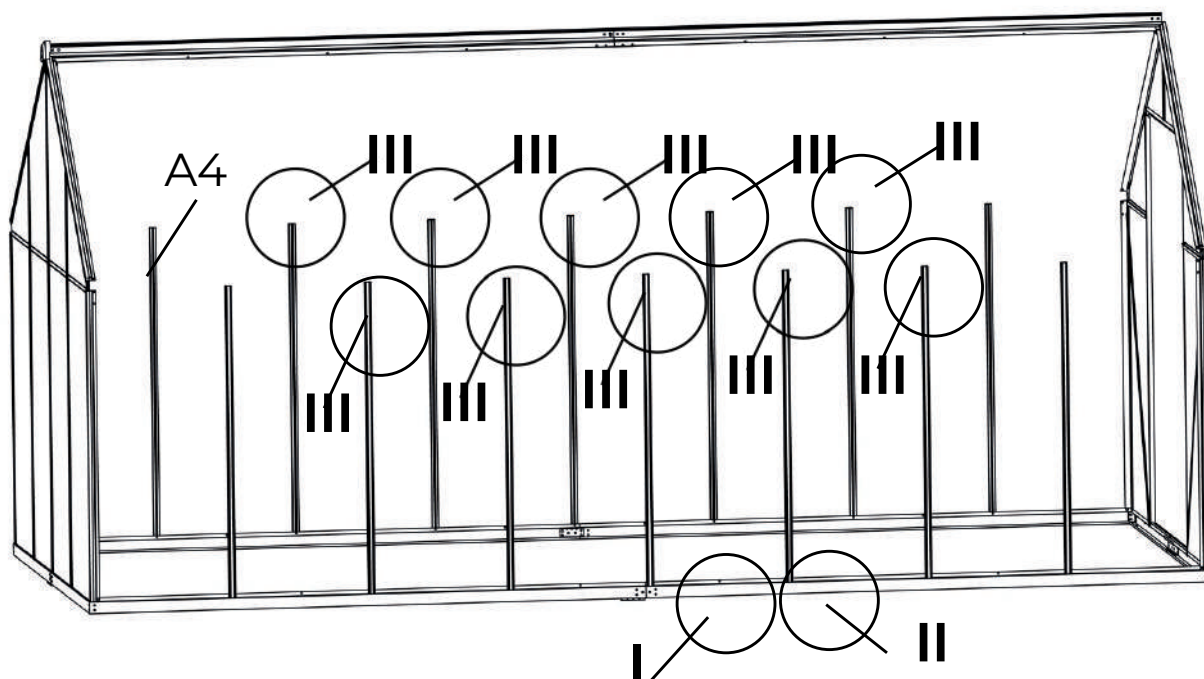

16



F4
30pcs



F5
30pcs



A28
8pcs

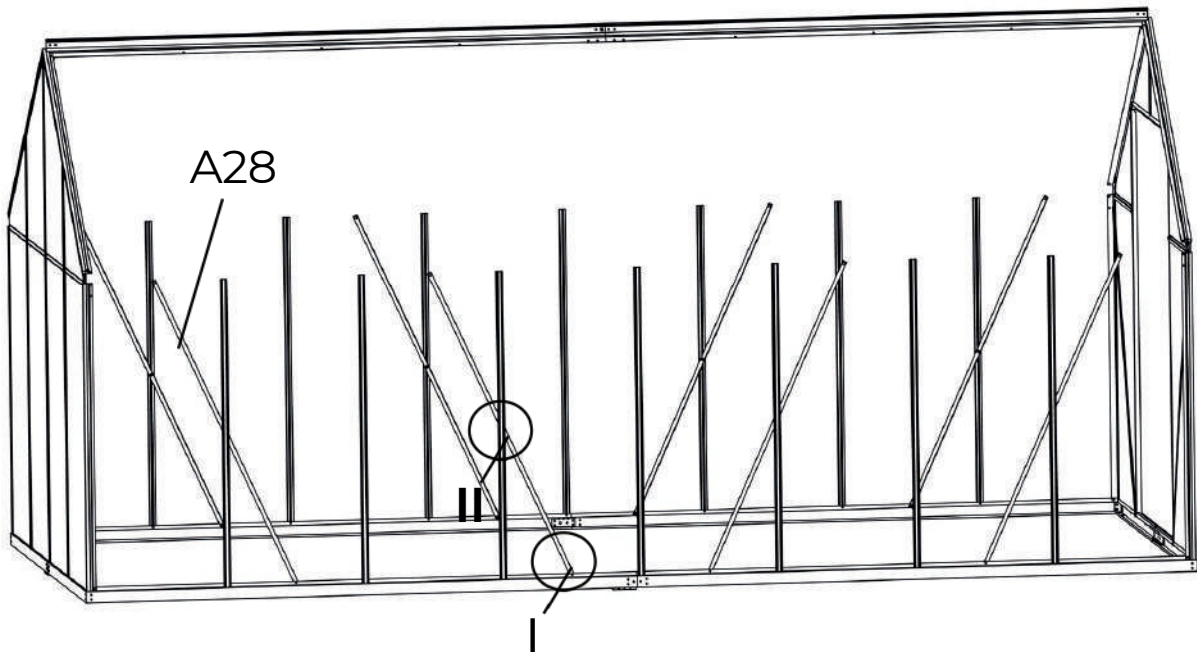
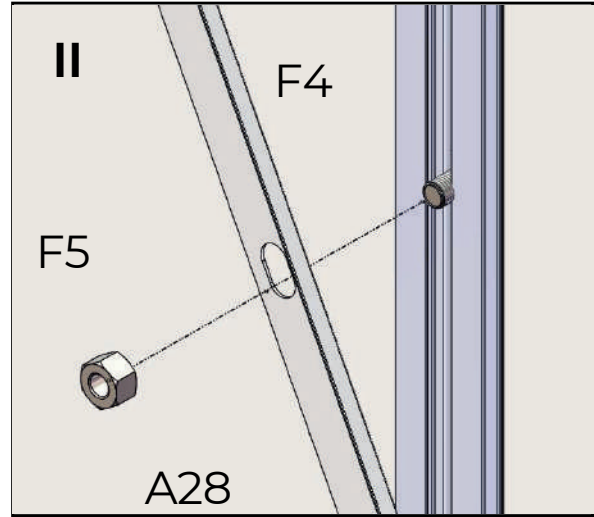
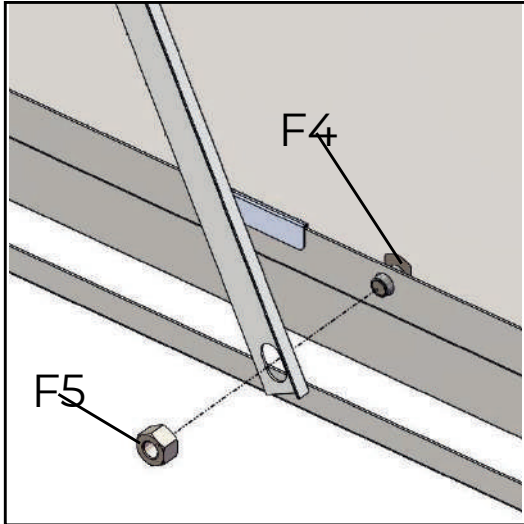

17

C21
16pcs

P2
16pcs

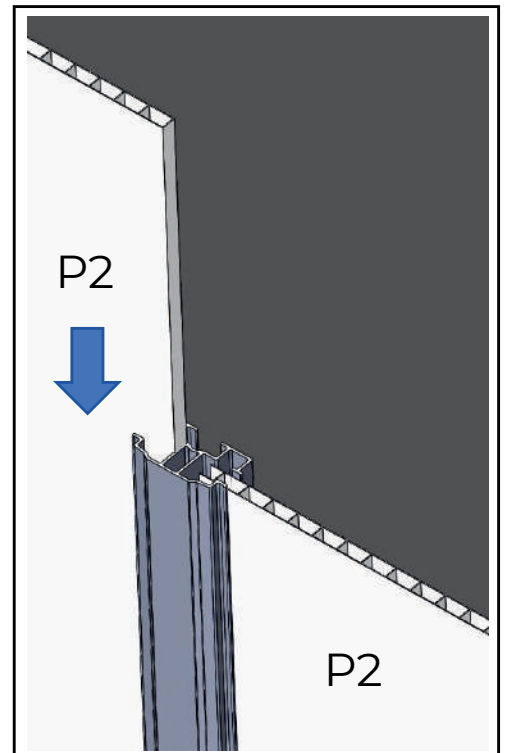
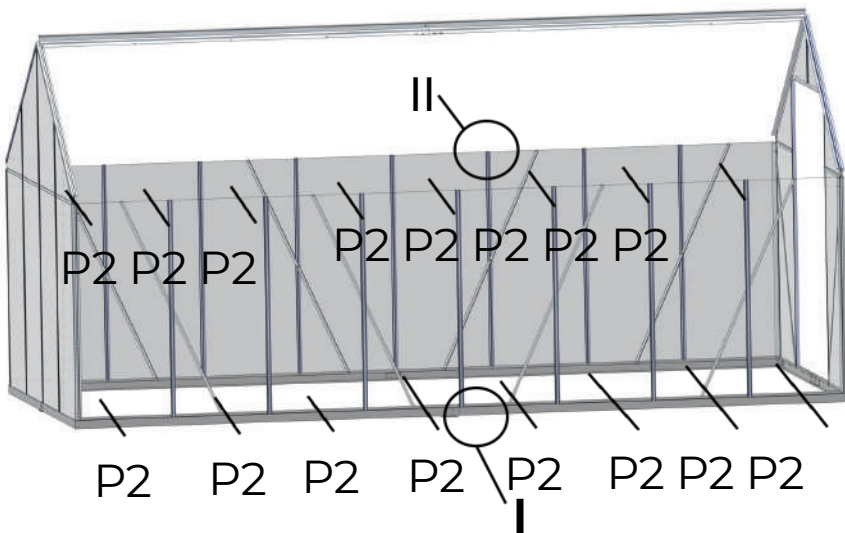
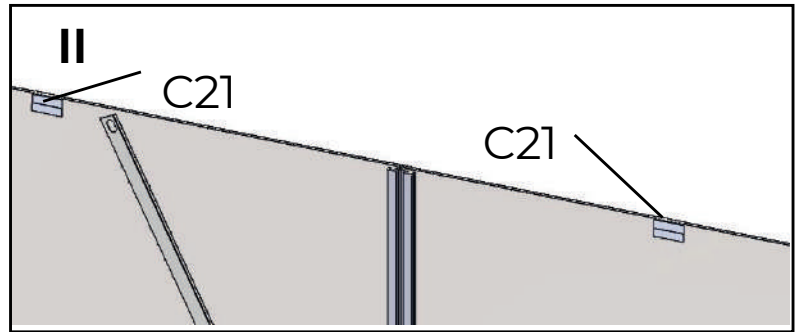
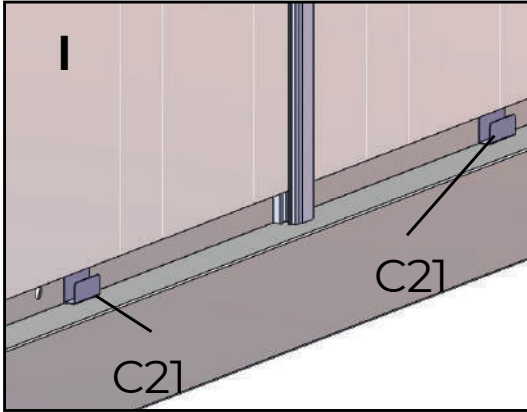

18

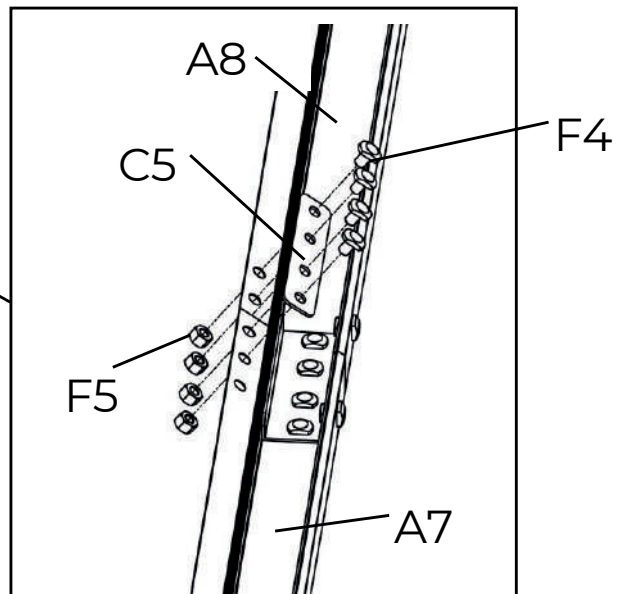
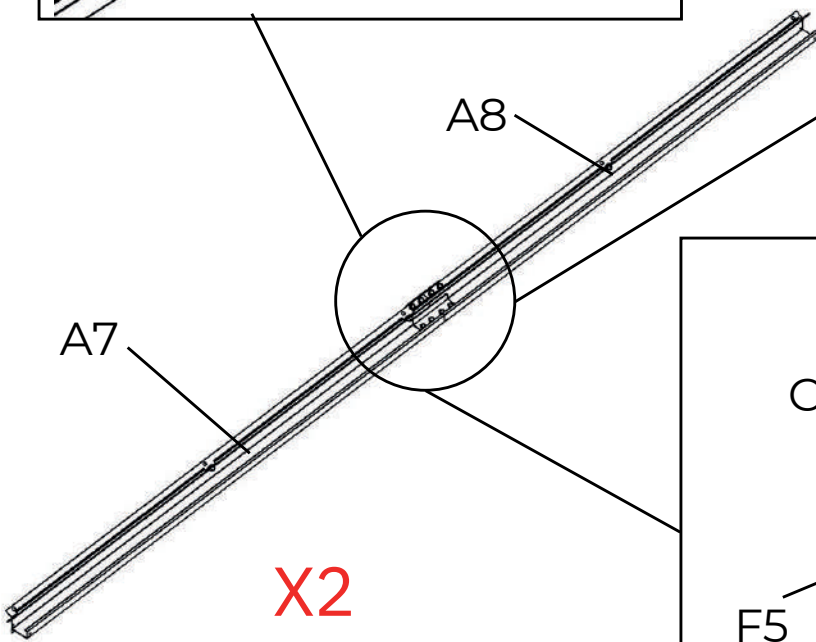
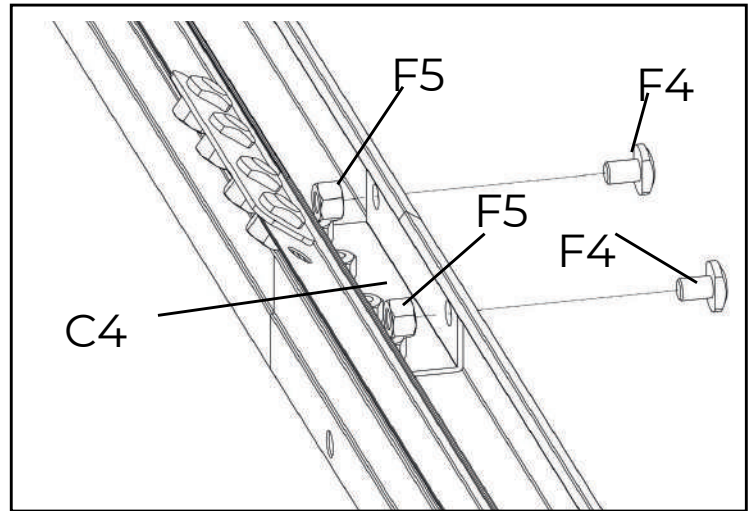
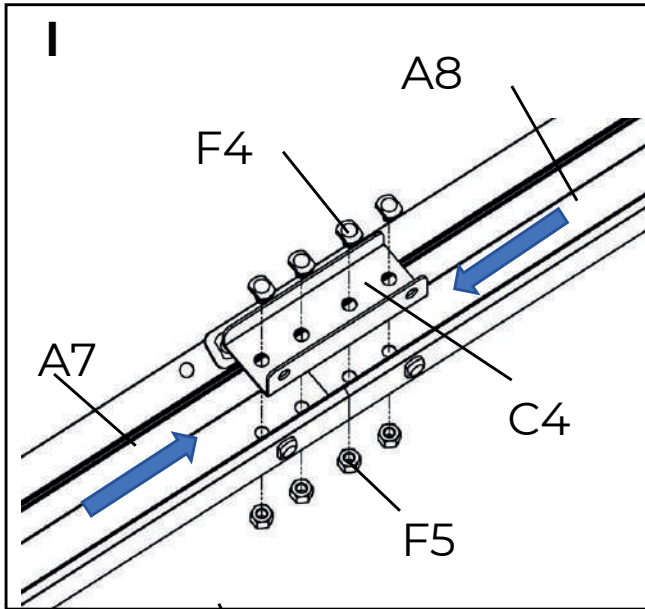
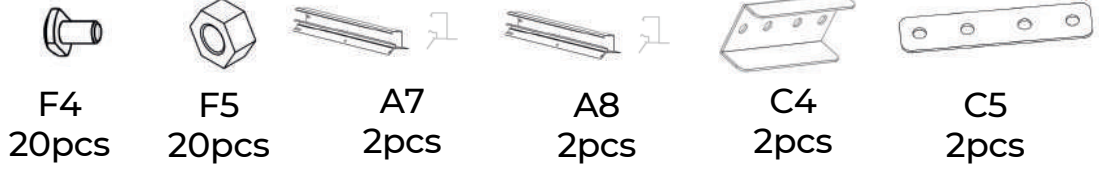

19

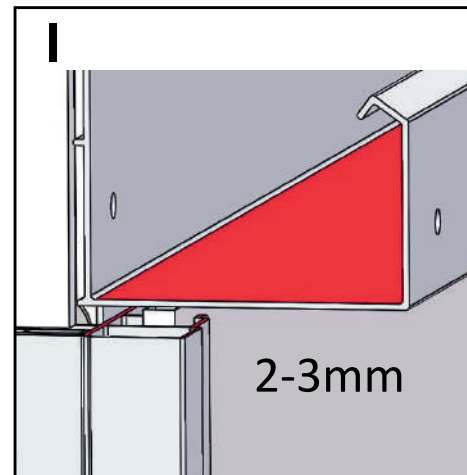
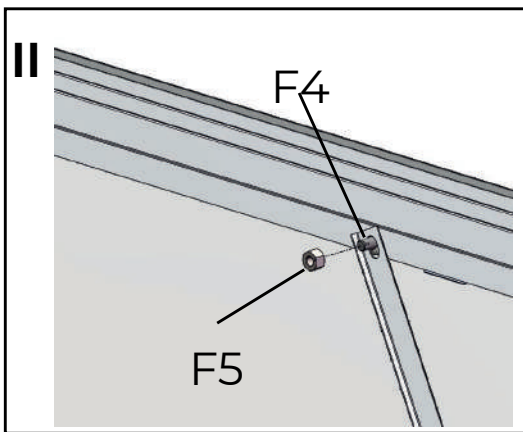
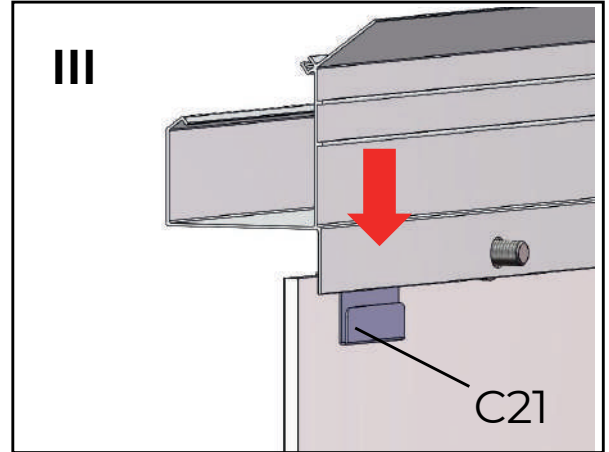
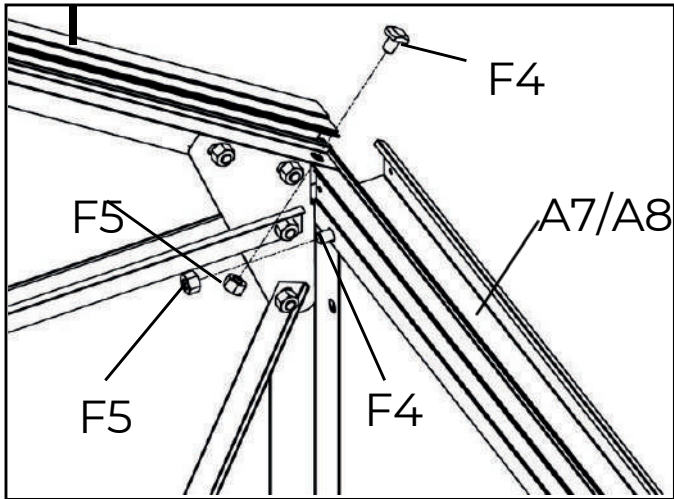
F4
30pcsF5
30pcs

Uwaga: Podczas montażu A7/A8 należy pozostawić odstęp 3-4 mm, aby później móc zamontować R2 i R3.

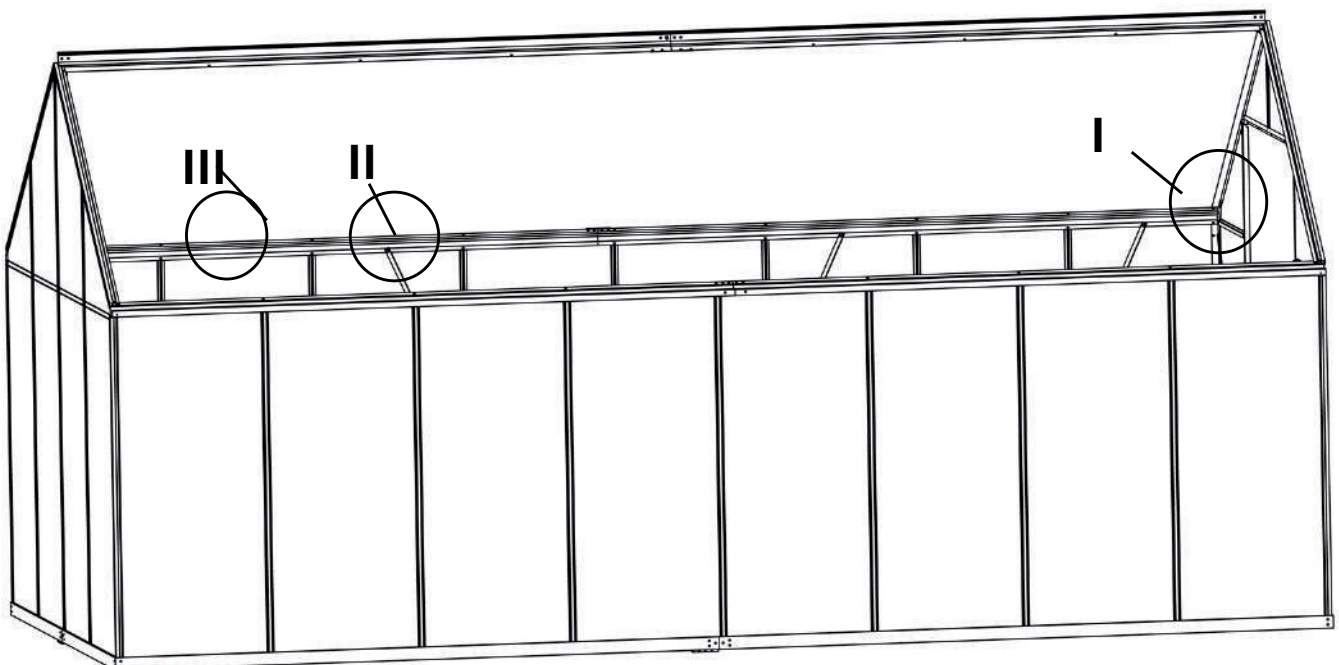

20



F4
56pcs



F5
28pcs



A6
14pcs

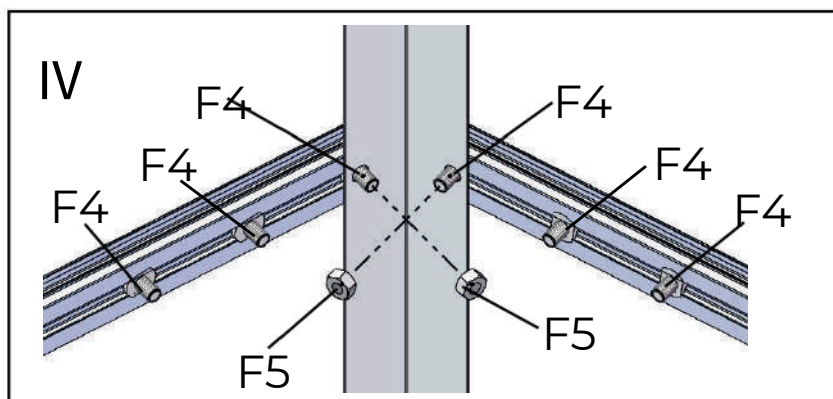
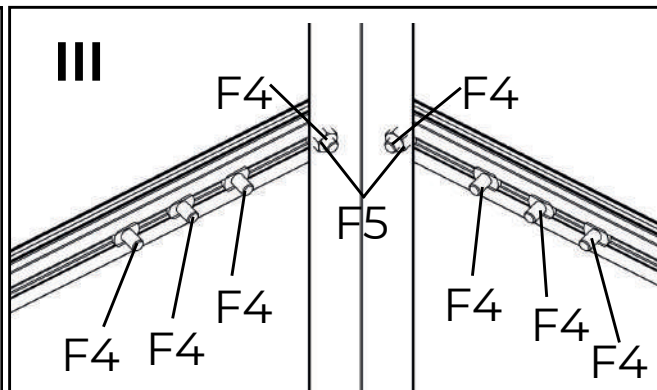
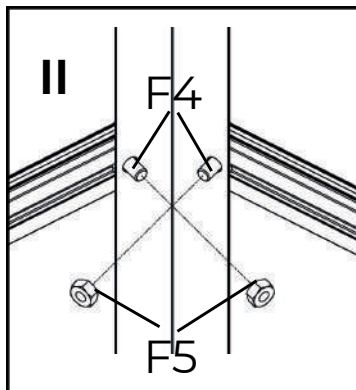
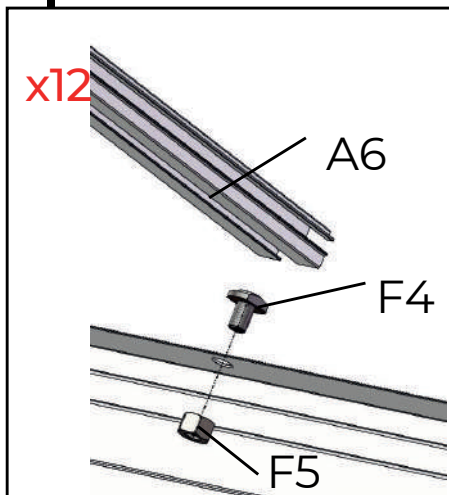

Uwaga: Należy wcześniej dodać dodatkowy element F4 na otwór wentylacyjny i drążek wspierający.

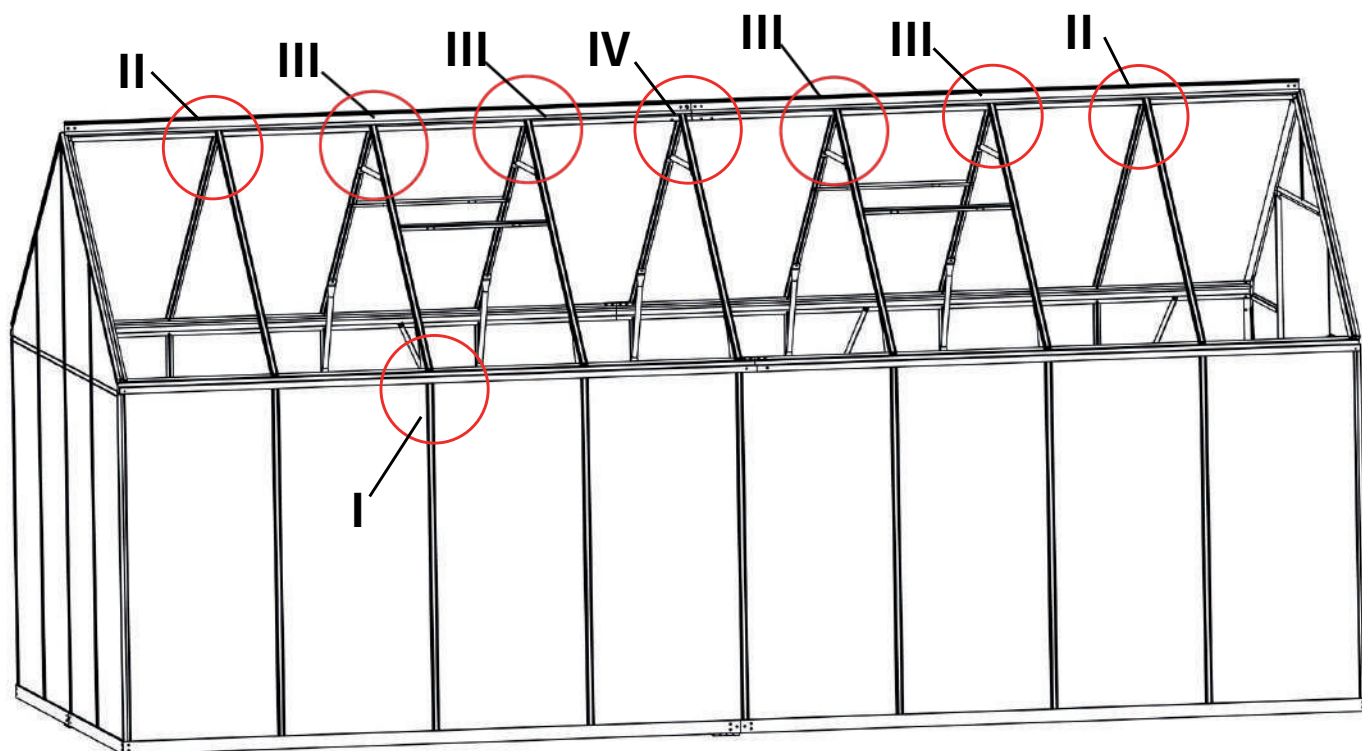

21



F5
28pcs



A22
4pcs



C14
5pcs



C15
10pcs

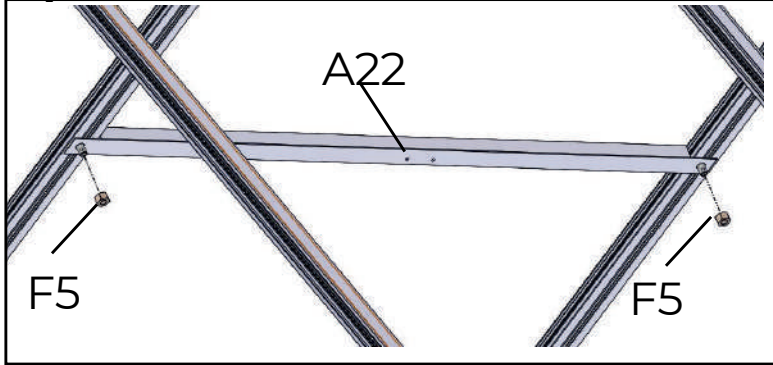

x4

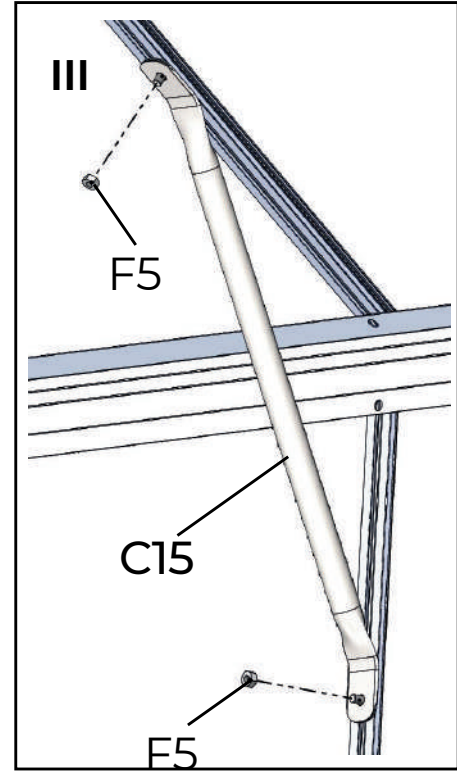

x10

x5

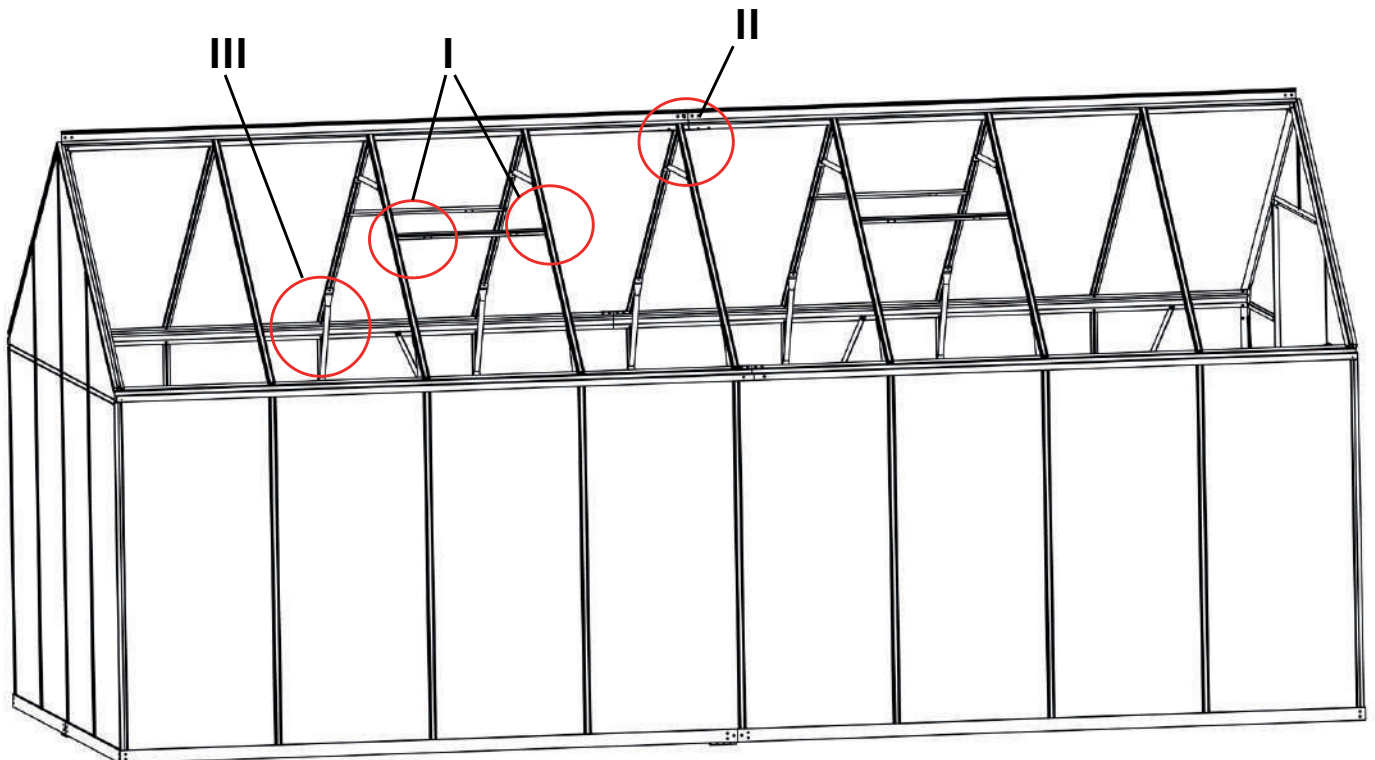
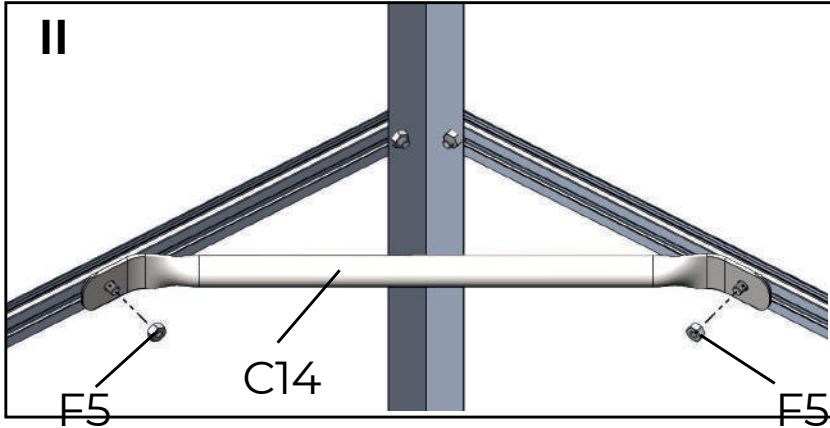

22

P3
12pcs

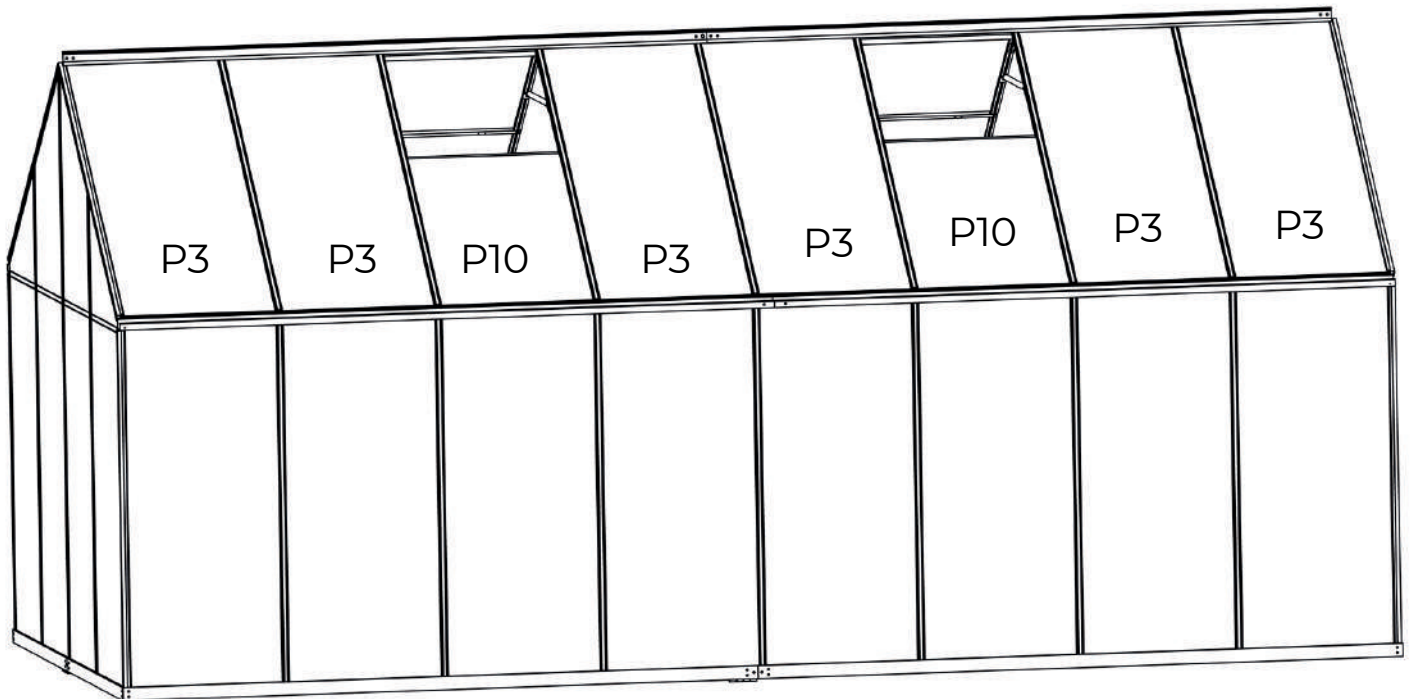
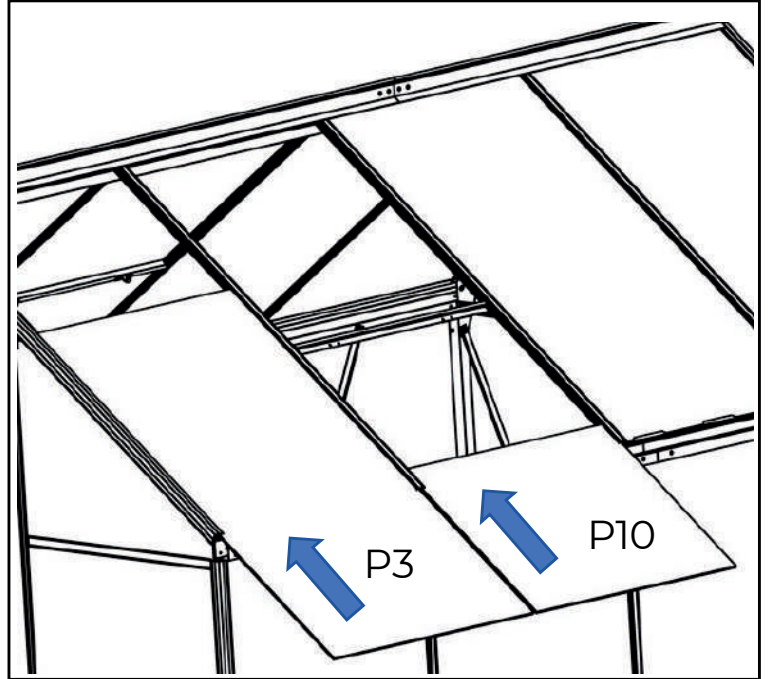
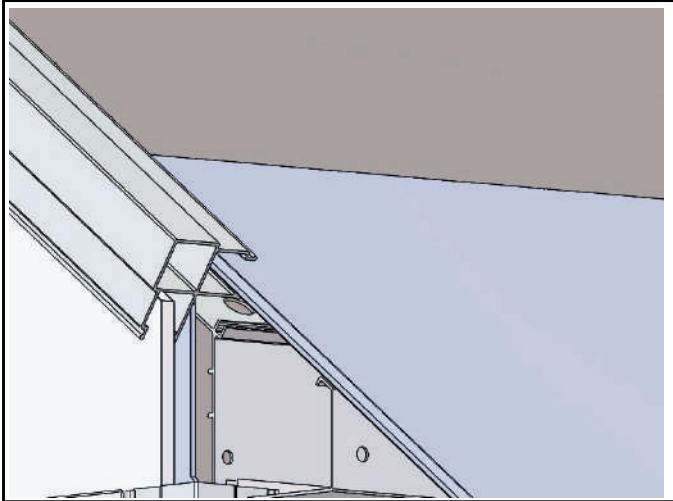

P10
4pcs

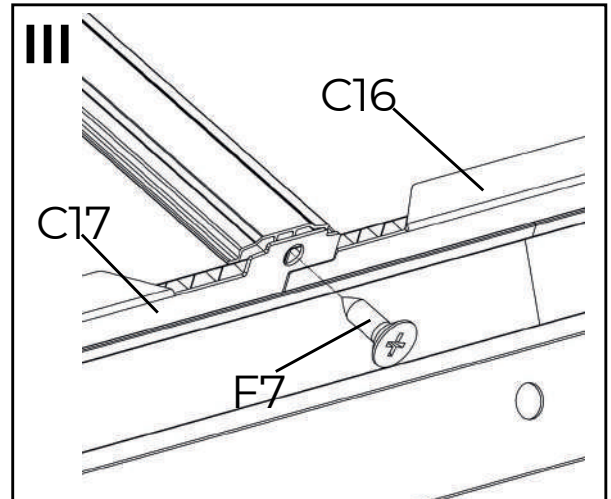
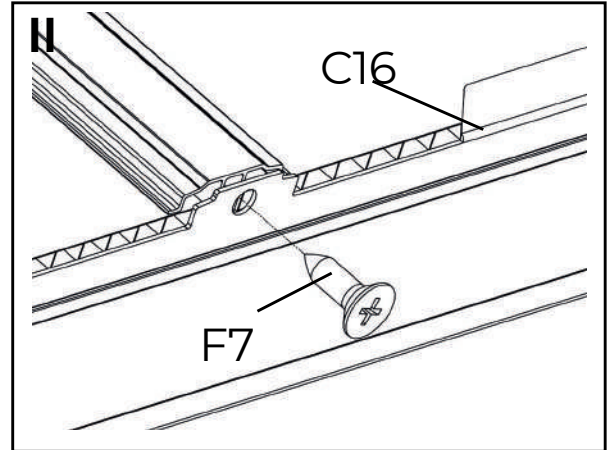
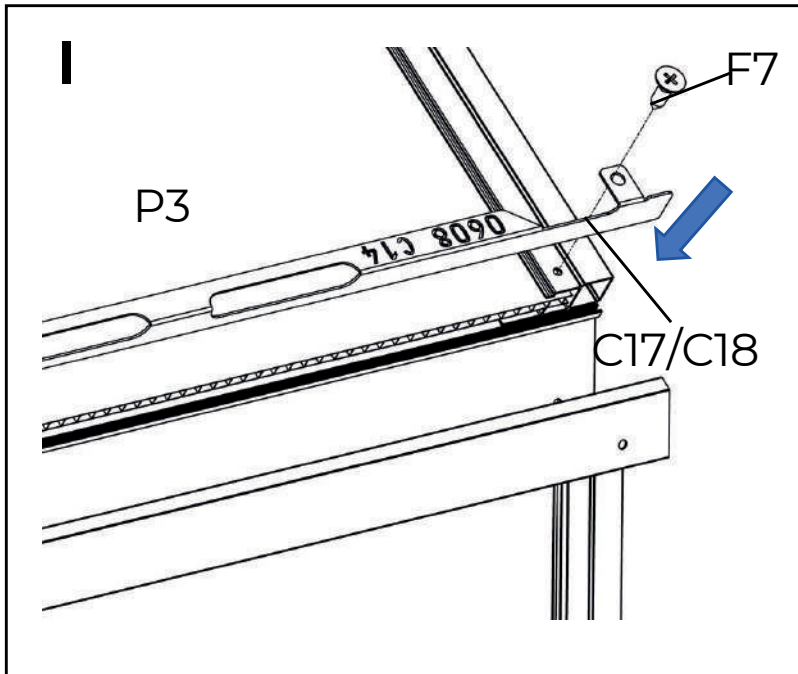

23

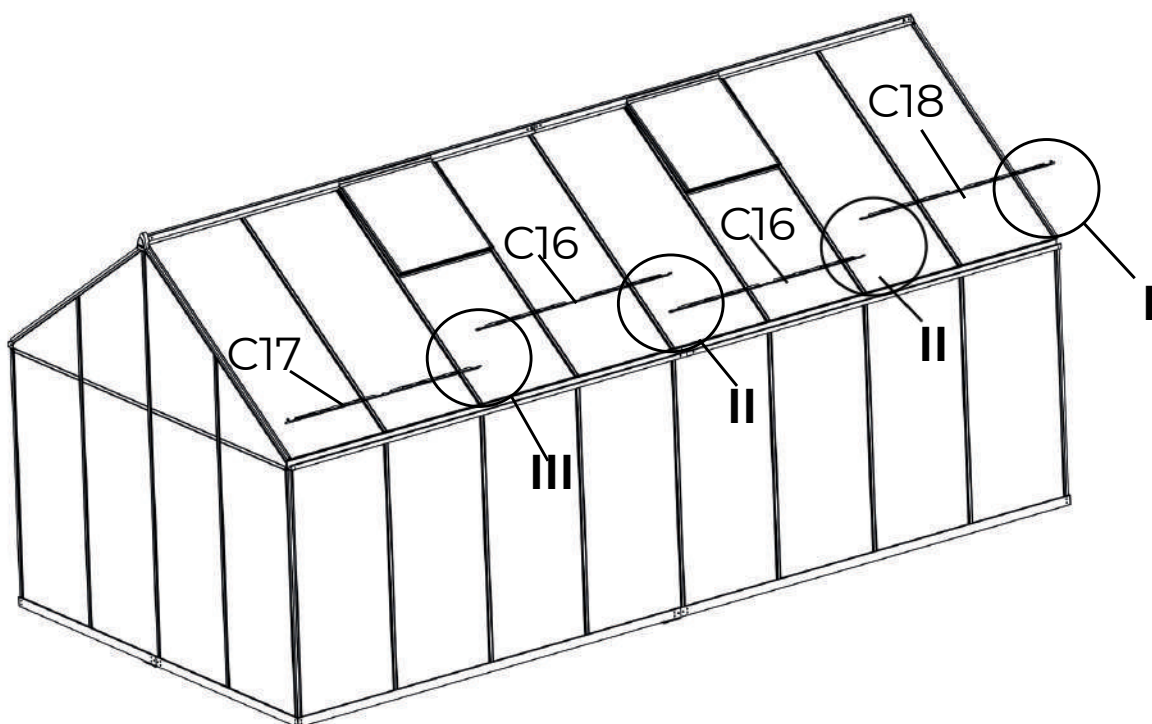

Uwaga: Włóż C16/C17/C18 do gniazda.



24



B2
8pcs



F6
16pcs

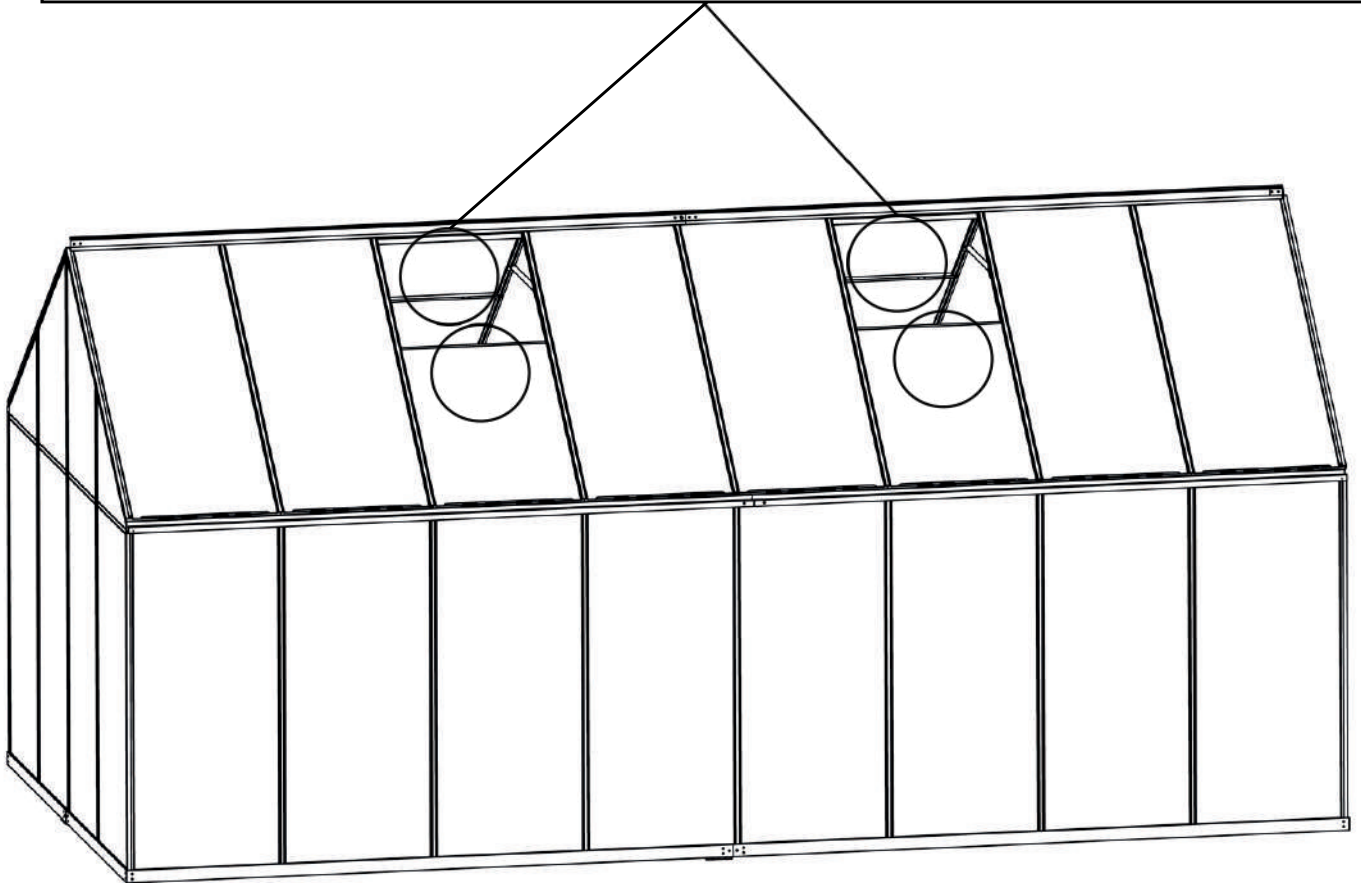
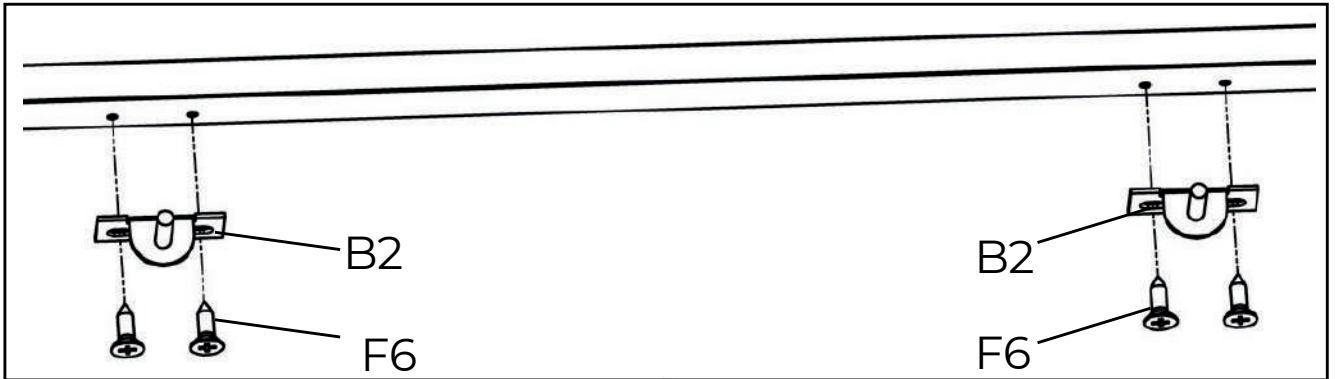

25



F4 16pcs
F5 16pcs
F6 16pcs

A23 4pcs

B1 8pcs

A24 4pcs

A21R 4pcs

A21L P9 4pcs 4pcs

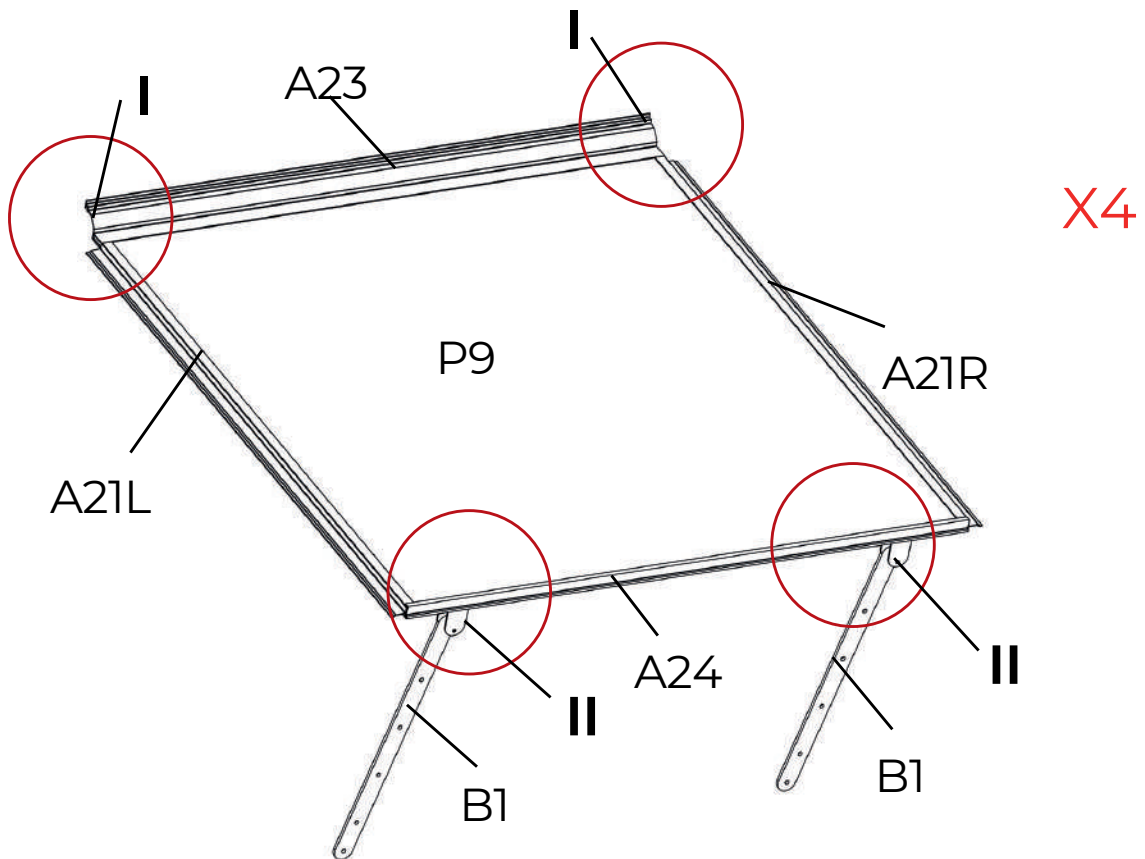
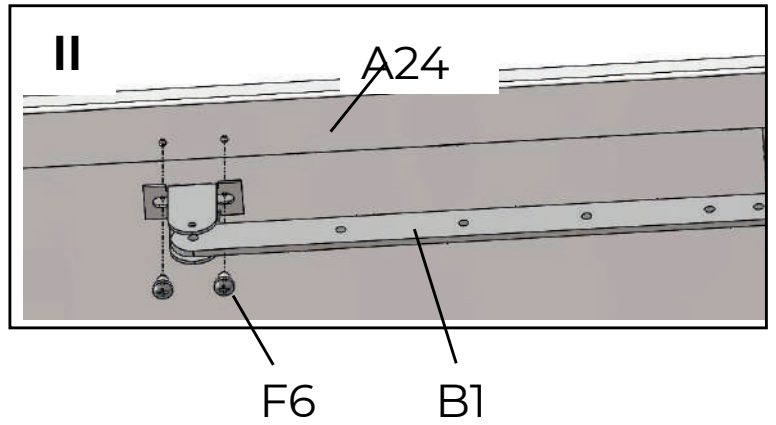
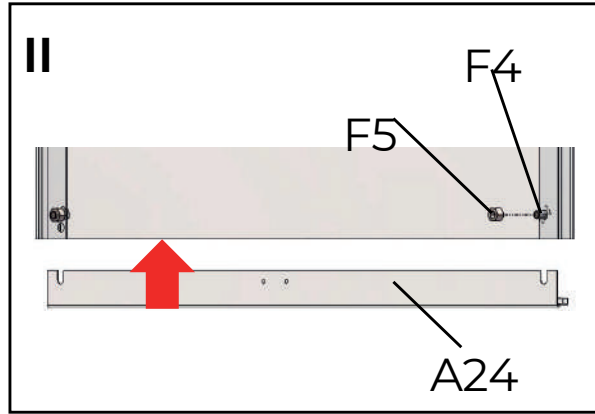
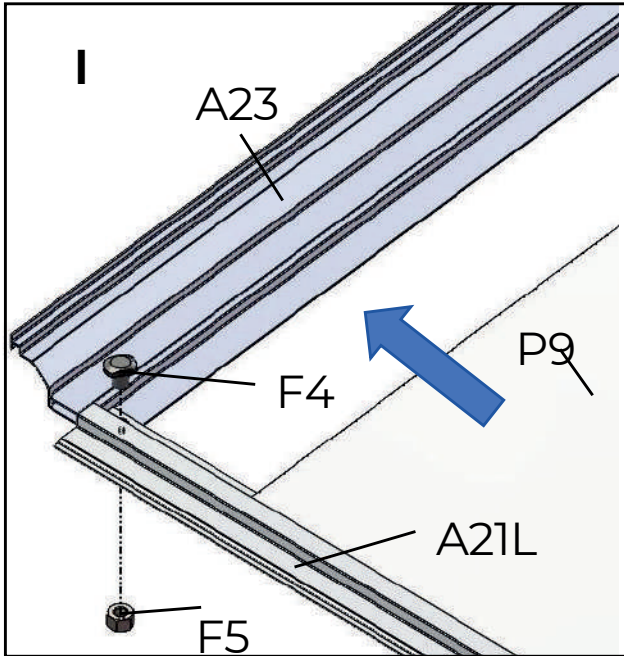

26

Wsuń szyberdach do szczeliny od lewej lub prawej strony i przesuń go do pozycji szyberdachu.

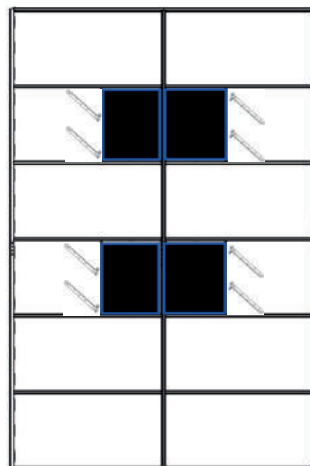
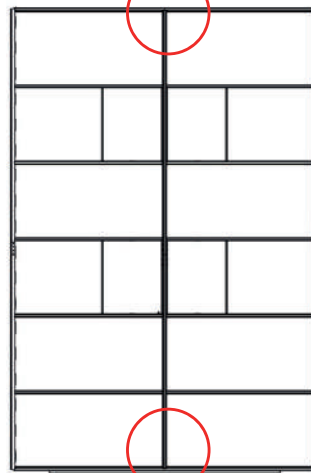
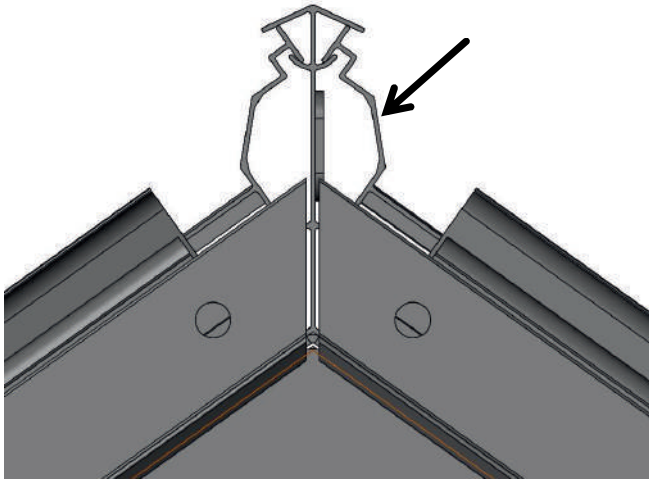

27



C19
2pcs



F4
6pcs



F5
4pcs



F1
4pcs



P8
1pcs



A11
2pcs



A17
1pcs

Prawe drzwi

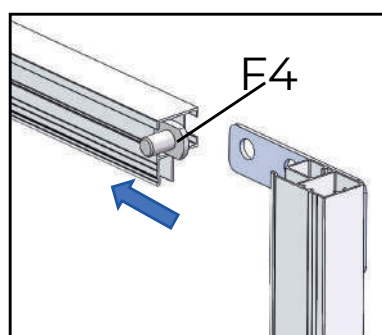
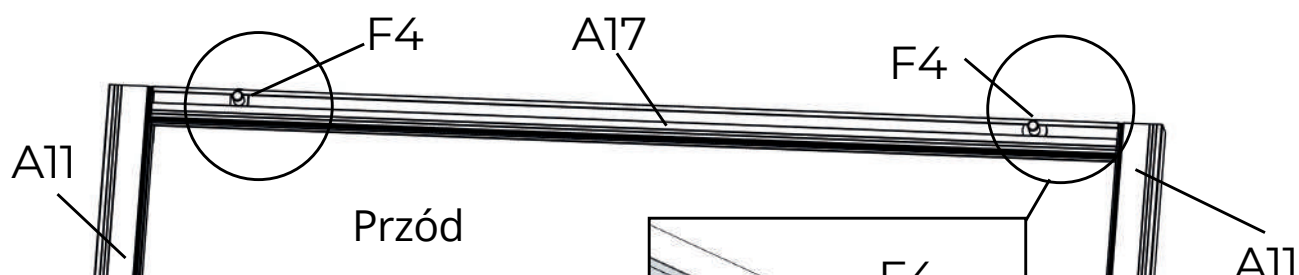
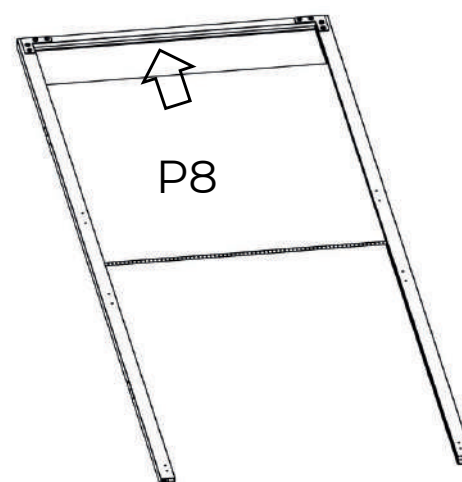
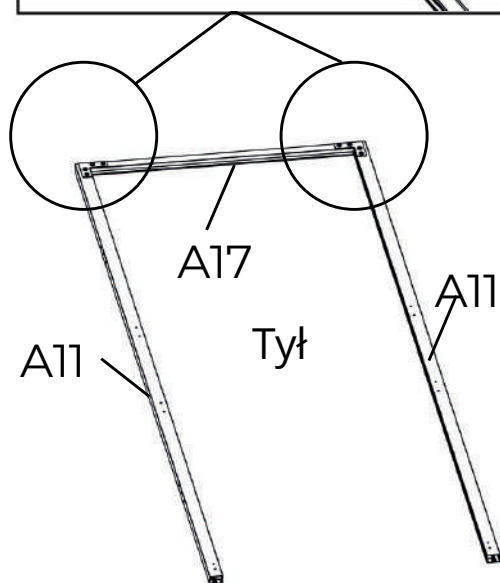
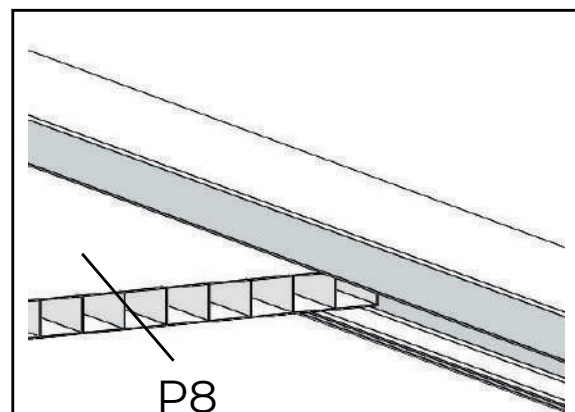
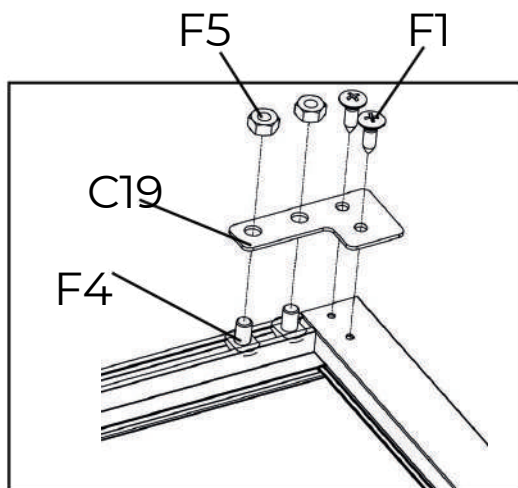

Uwaga: Zainstaluj wstępnie dwa F4, aby później podłączyć A2.

28



F4
8pcs



F5
8pcs



F1
8pcs



P8
1pcs



C20
4PCS



A18
1pcs



A19
1pcs

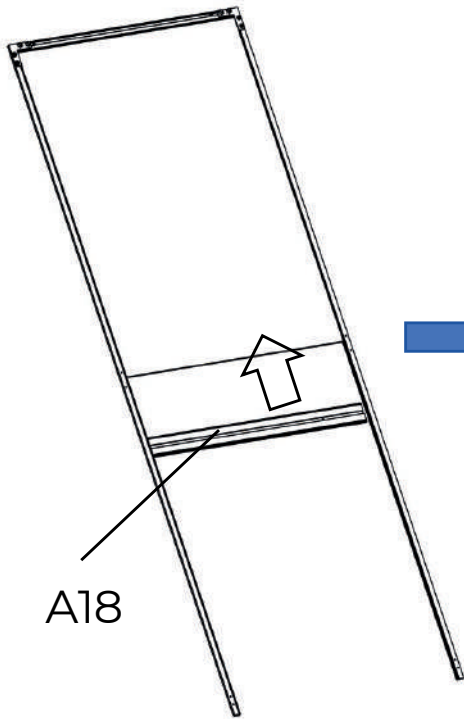

A18

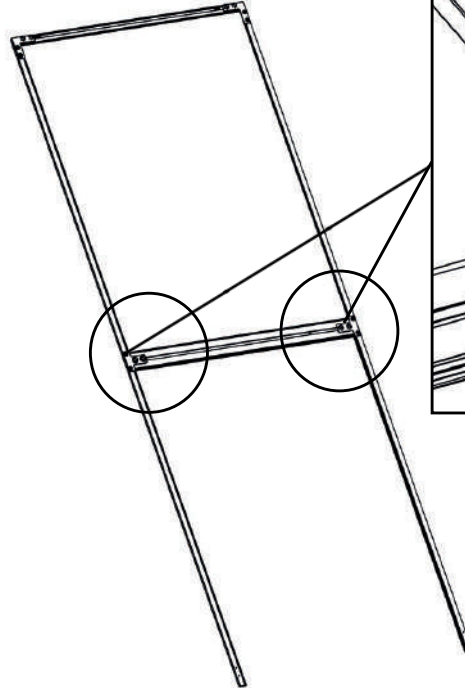

A19

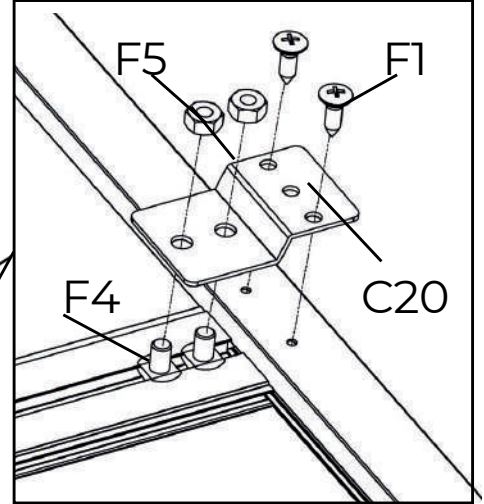

F5

F1

F4

C20

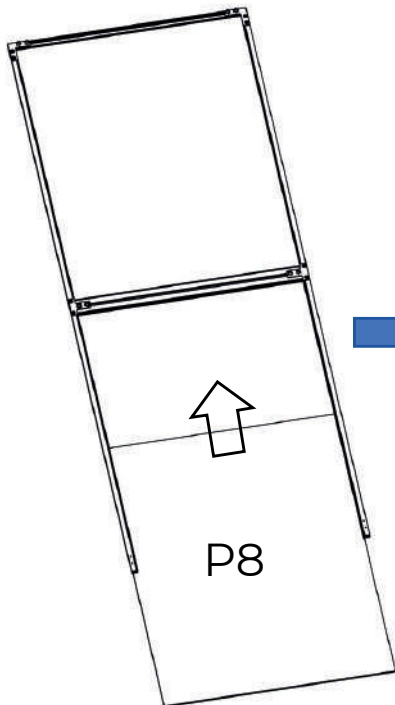

P8

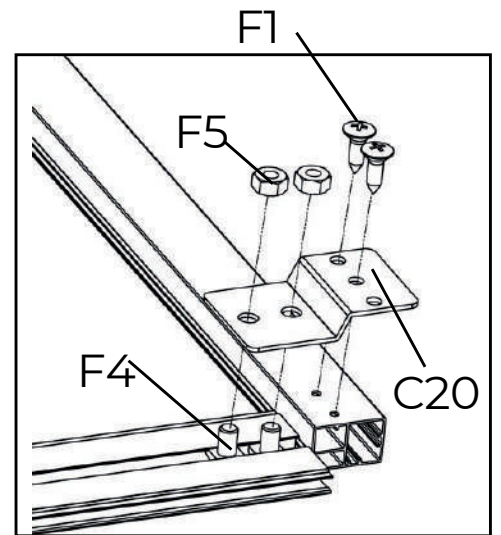
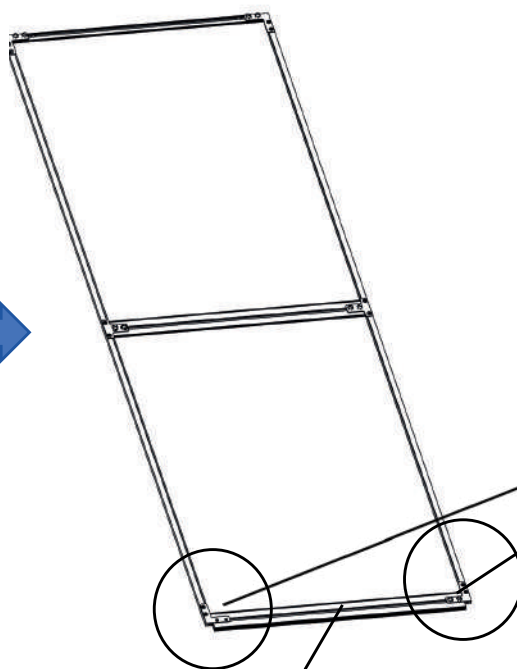

F1

F5

F4

C20

29

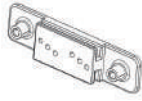

S1
2pcs



S2
4pcs



F2
4pcs



F3
4pcs



F8
4pcs



F7
4pcs



B4
1pcs

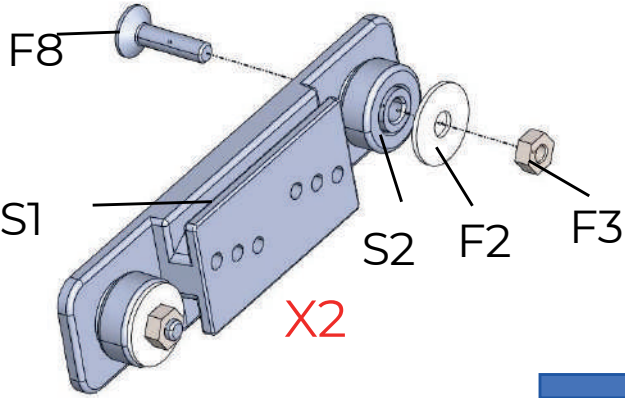

Te 3 otwory służą do regulacji wysokości drzwi.

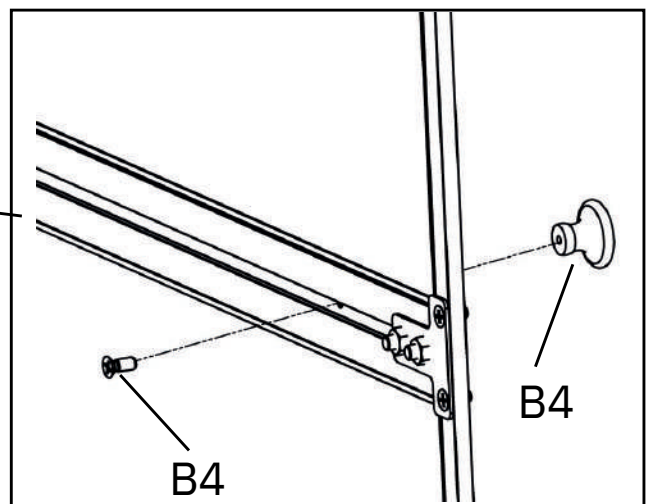
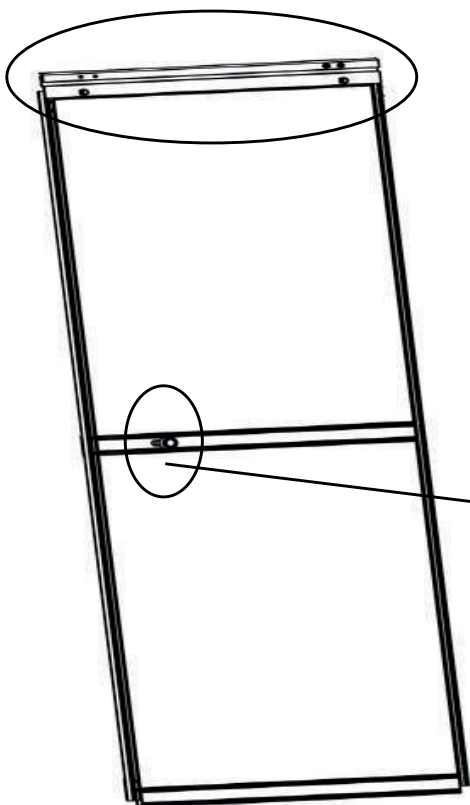
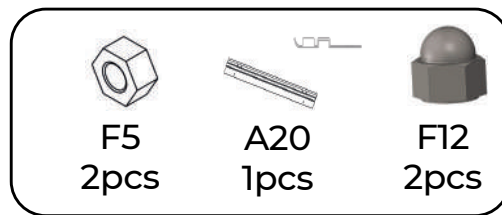
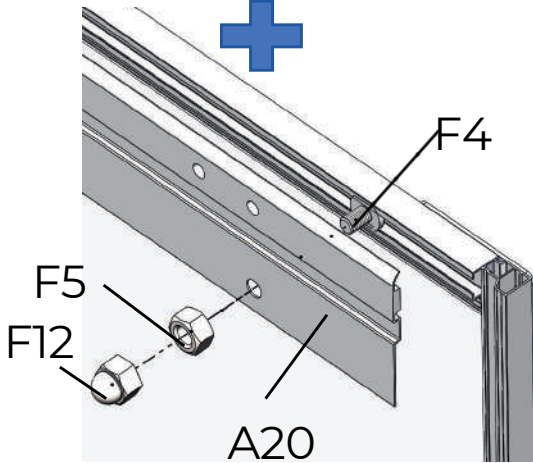
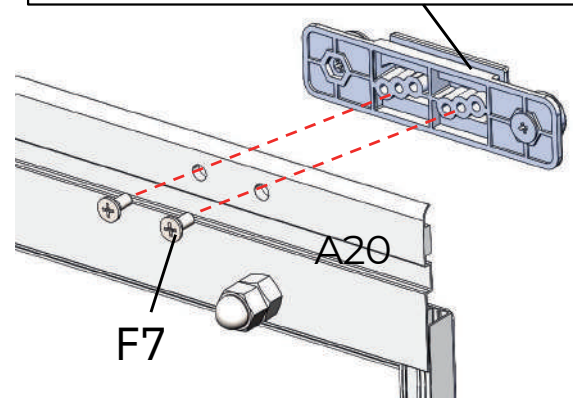

30

C19
2pcsF4
6pcsF5
4pcsF1
4pcsP8
1pcsA11
2pcsA17
1pcs

Drzwi lewe

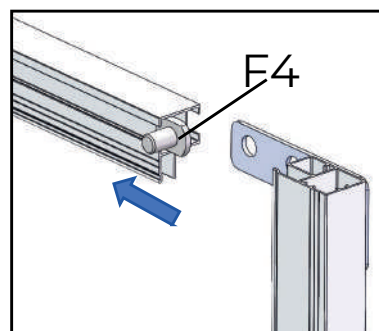
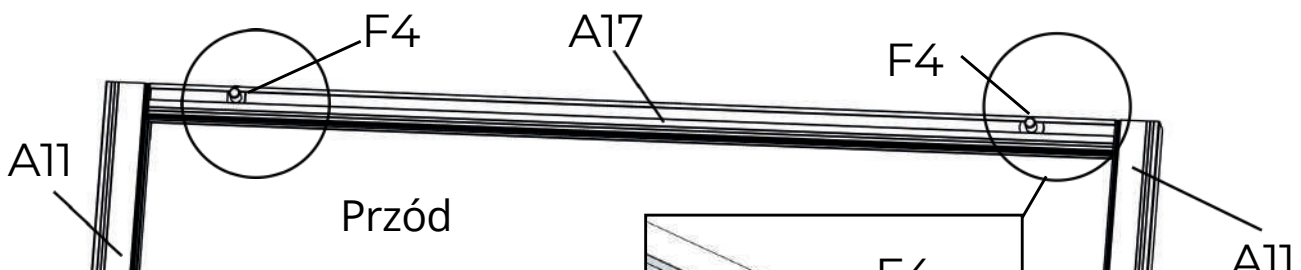
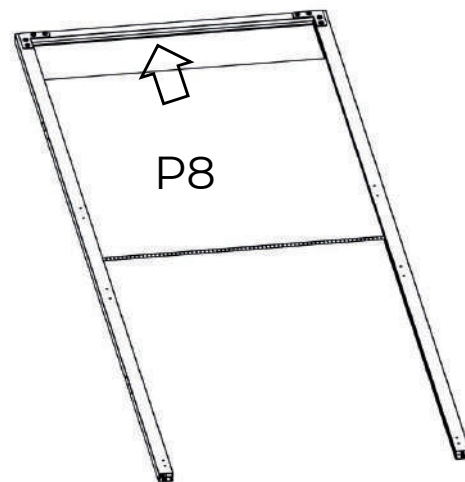
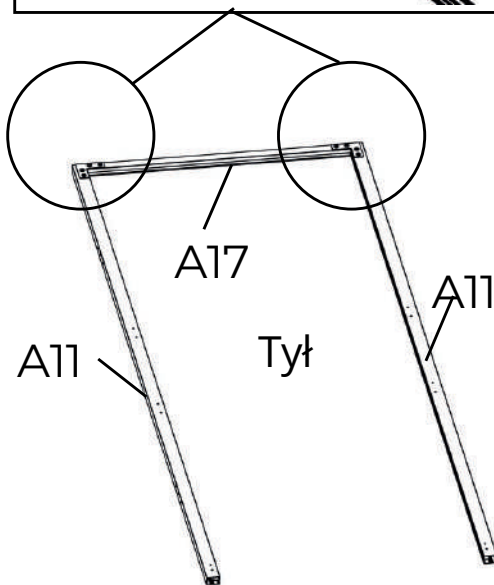
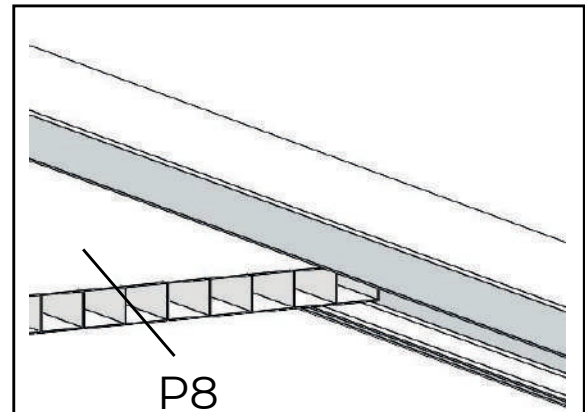
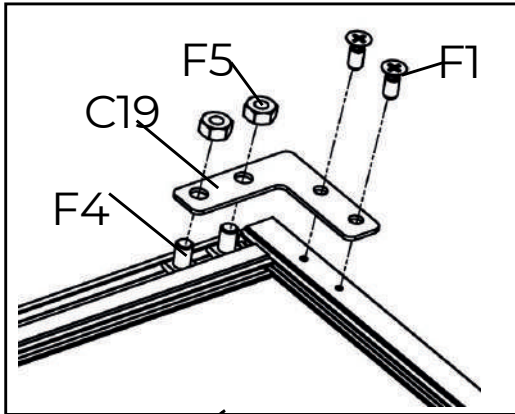

Uwaga: Zainstaluj wstępnie dwa F4, aby później podłączyć A2.

31



F4
8pcs



F5
8pcs



F1
8pcs



P8
1pcs



C20
4PCS



A18
1pcs



A19
1pcs

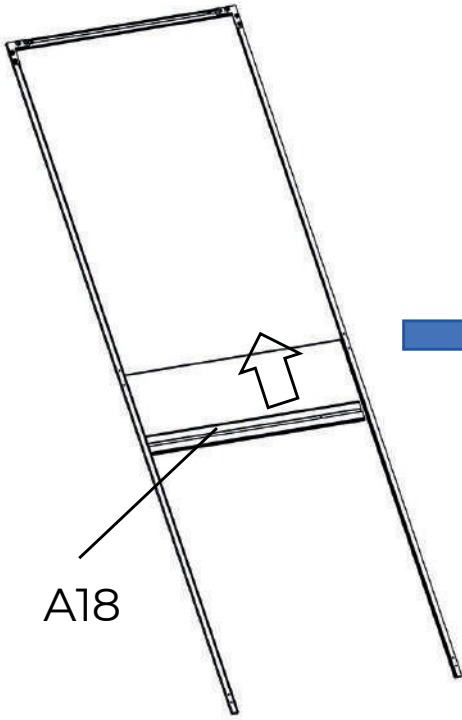

A18

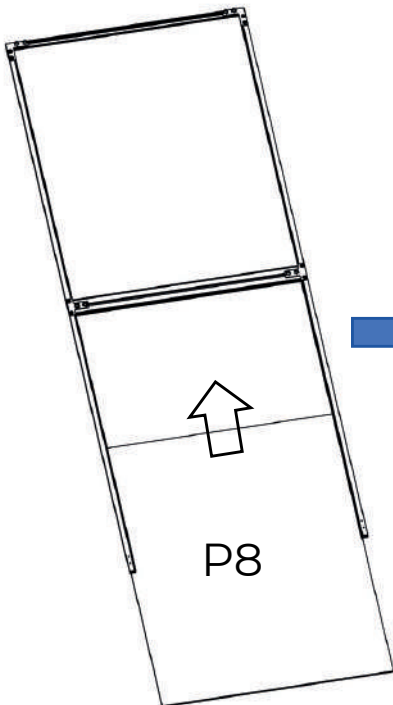
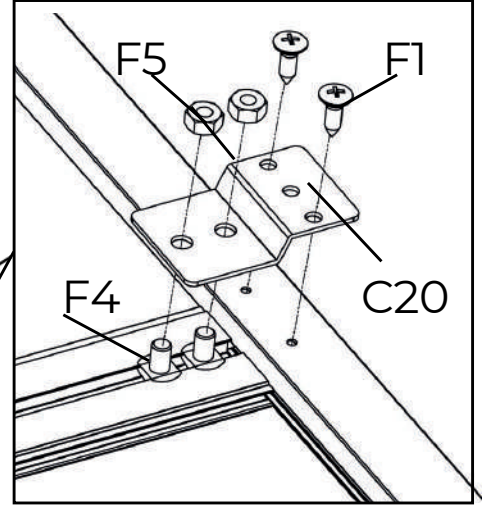
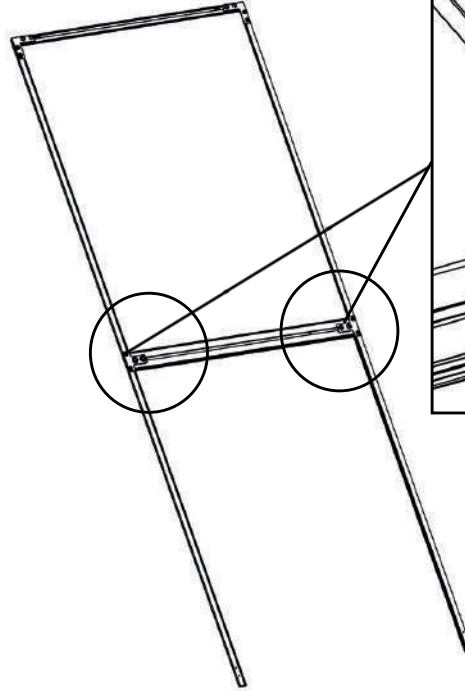

P8

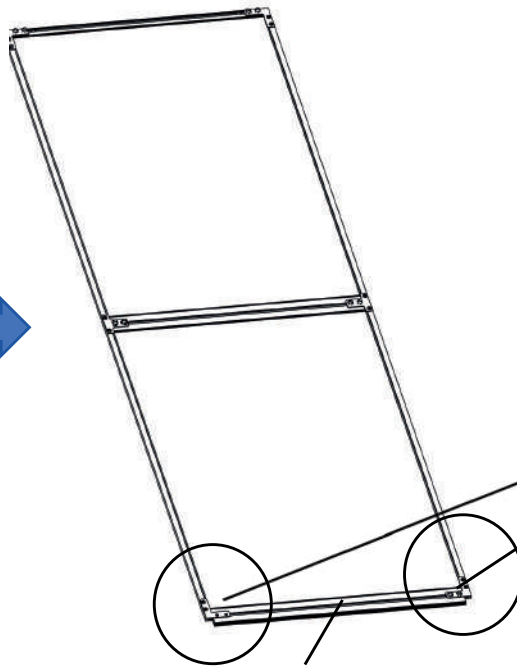

A19

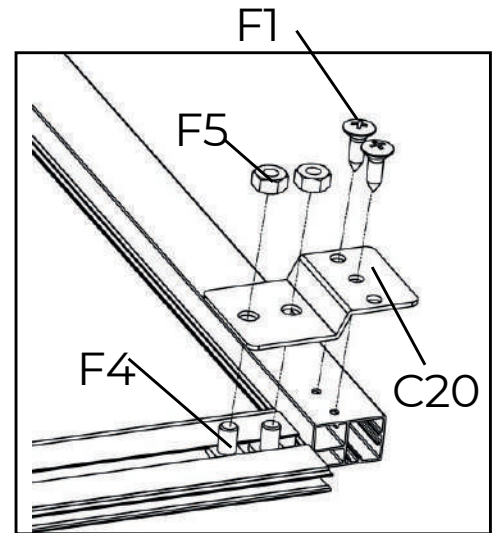

32

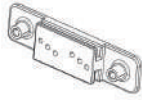

S1
2pcs



S2
4pcs



F2
4pcs



F3
4pcs



F8
4pcs



F7
4pcs



B4
1pcs

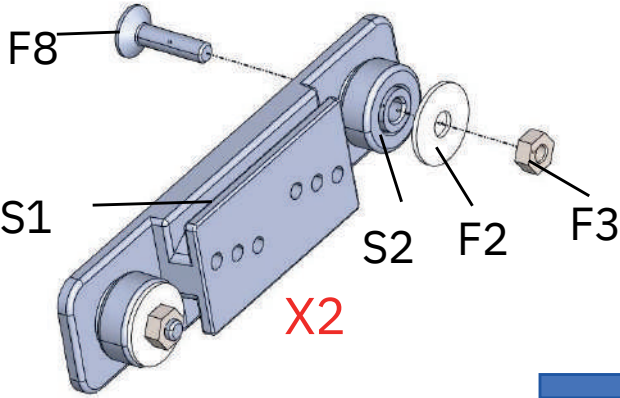

Te 3 otwory służą do regulacji wysokości drzwi.

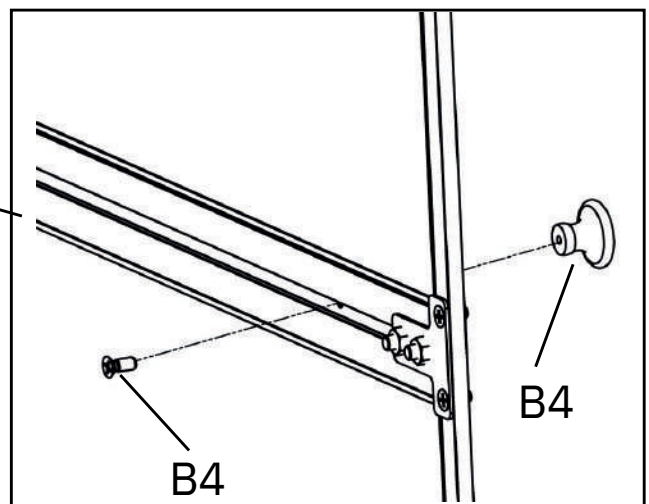
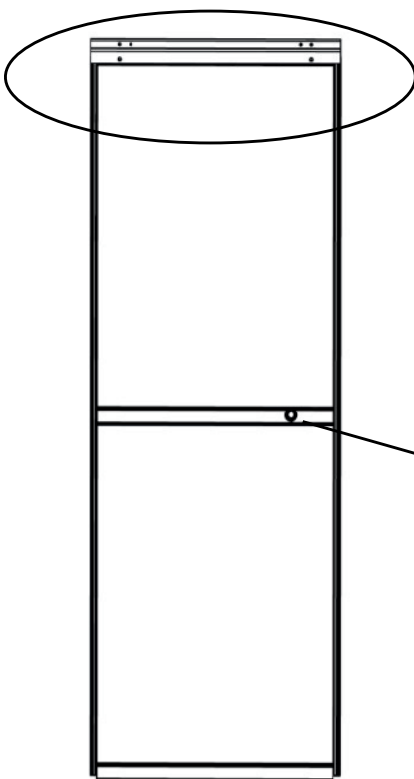
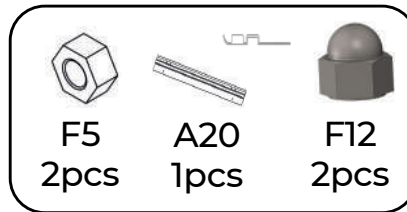
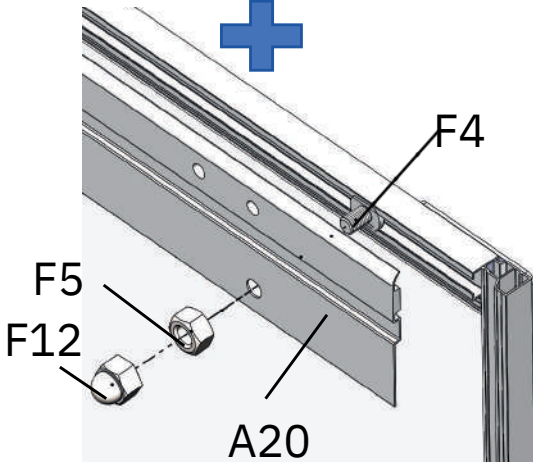
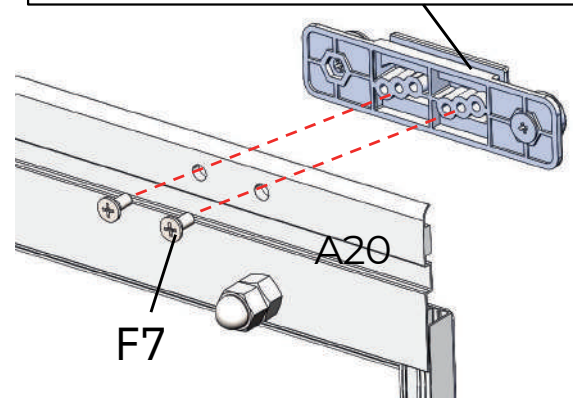

33



F4
5cs



F5
5pcs



A13
2pcs



A12



A14
1pcs



F9
1pcs

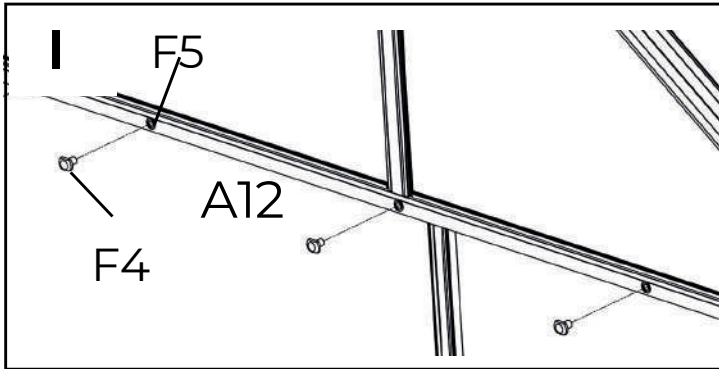

Uwaga: Nie dokręcaj mocno F4 i F5, a następnie wsuń F4 w A13.

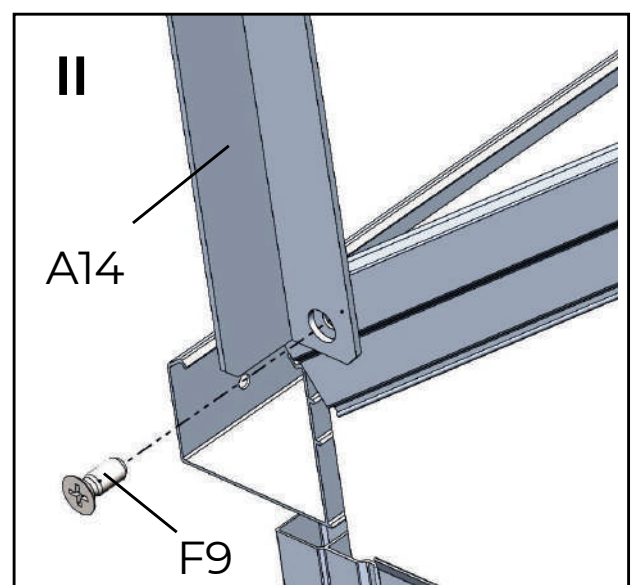
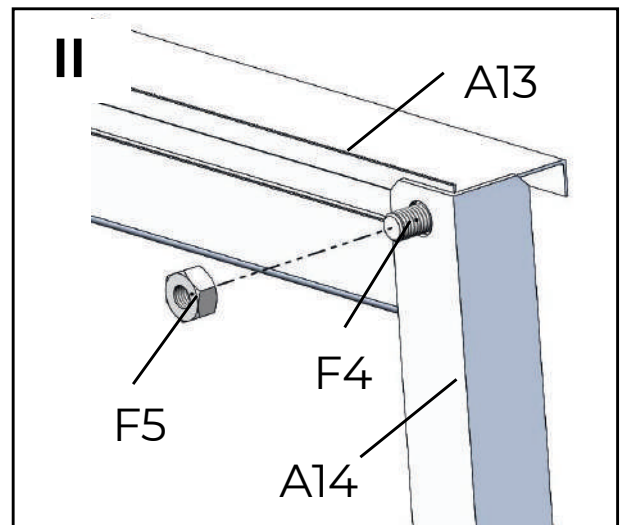
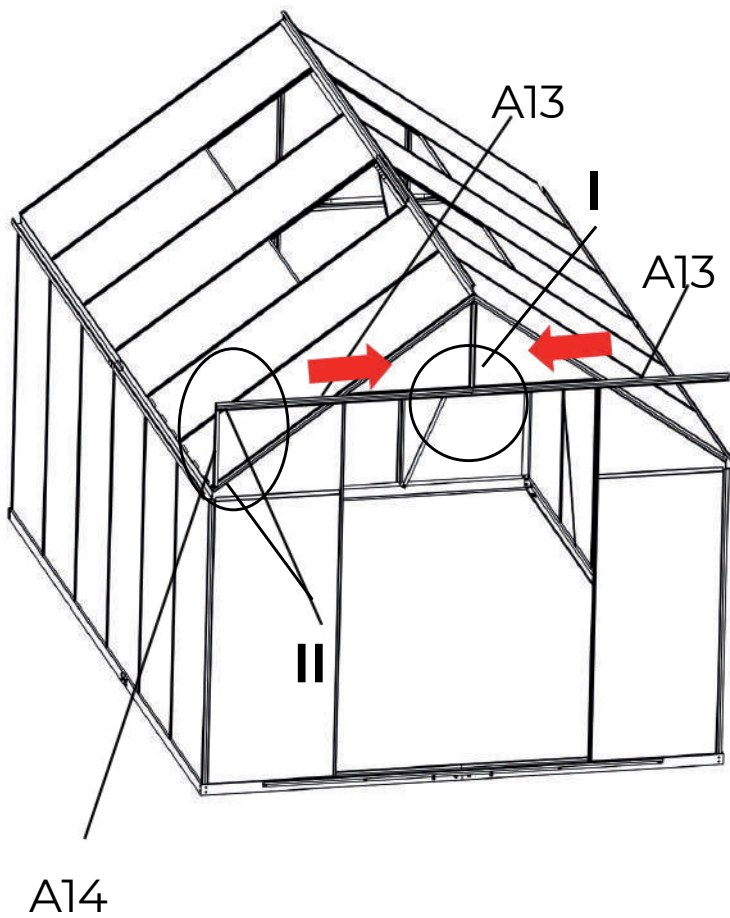
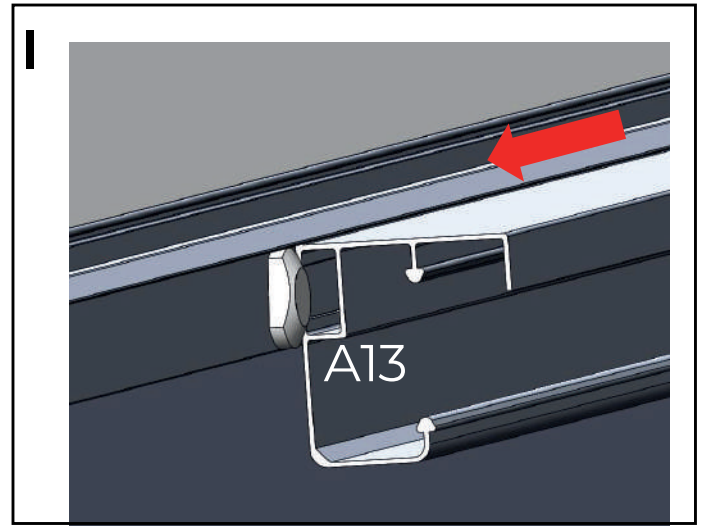

34

Uwaga: wsuwanie drzwi w szyny.

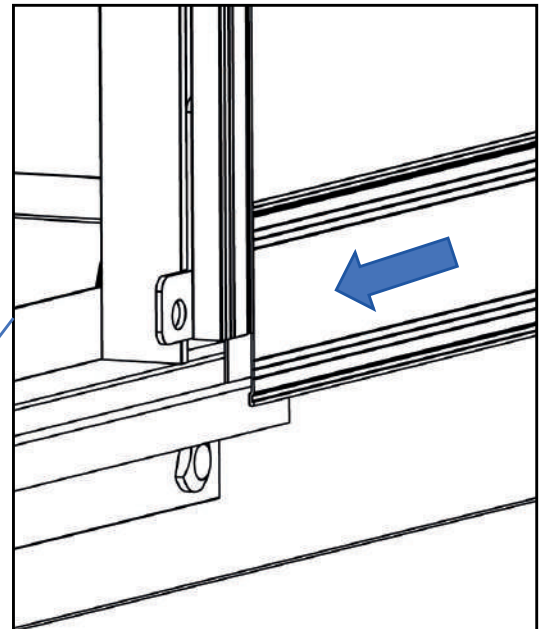
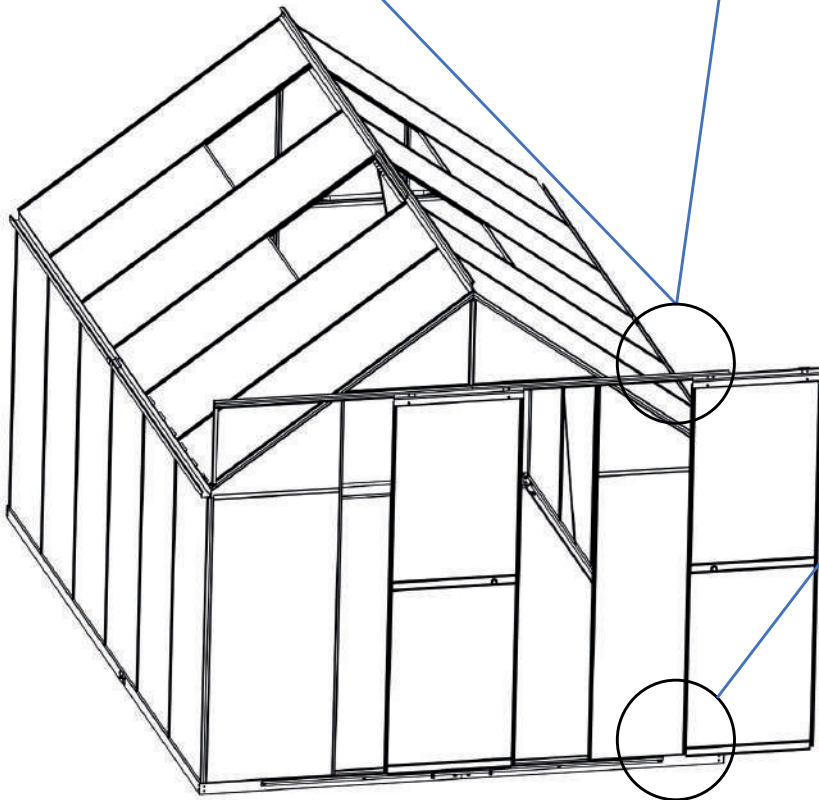
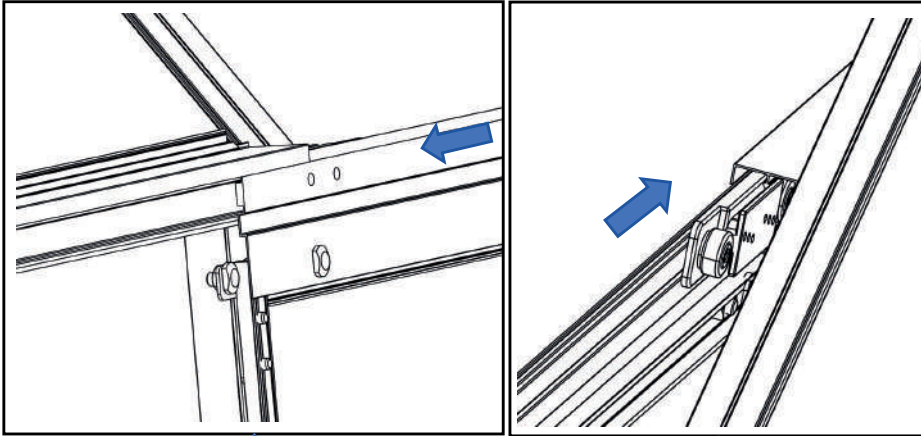

35



F4
1pcs



F5
1pcs



A14
1pcs



F9
1pcs

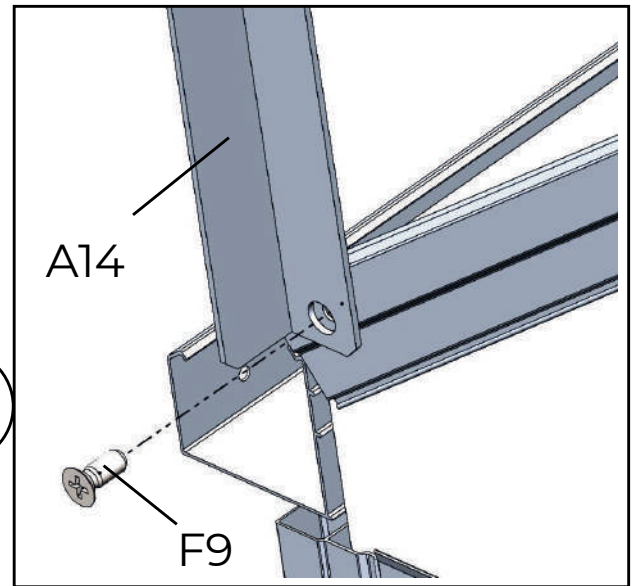
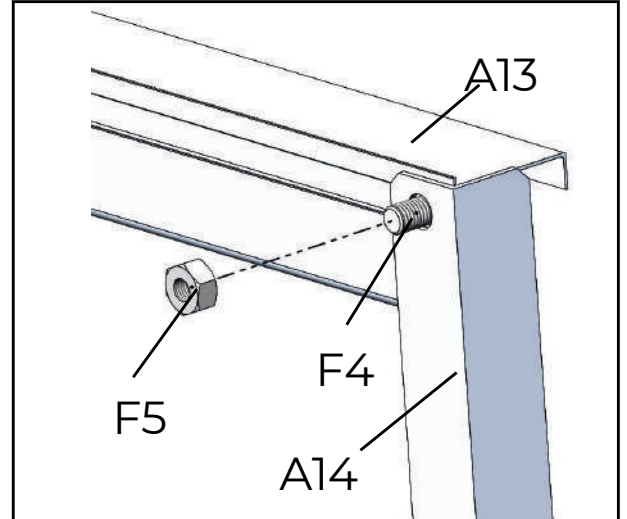
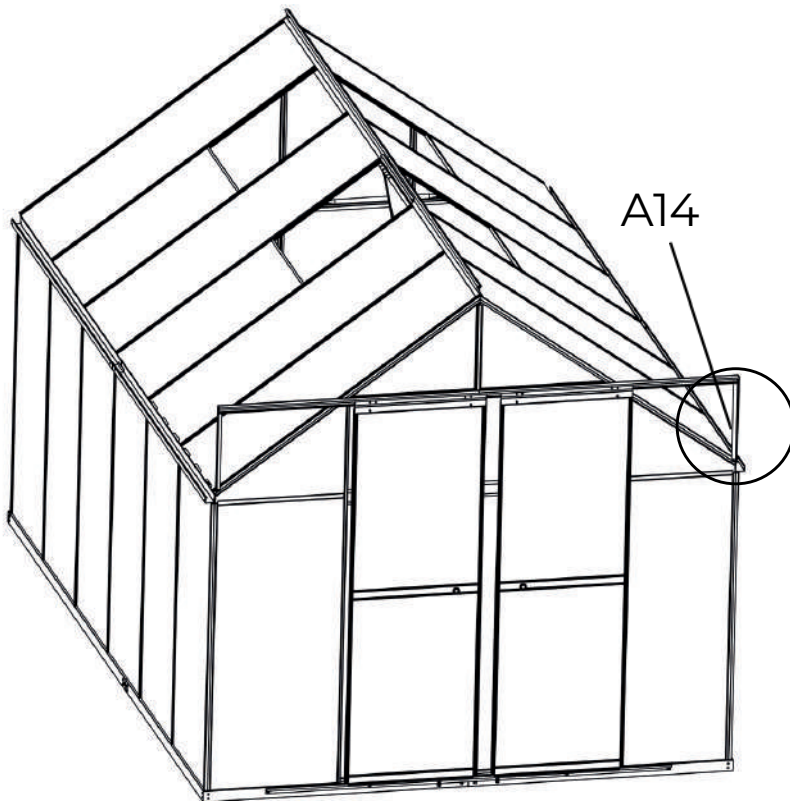

36

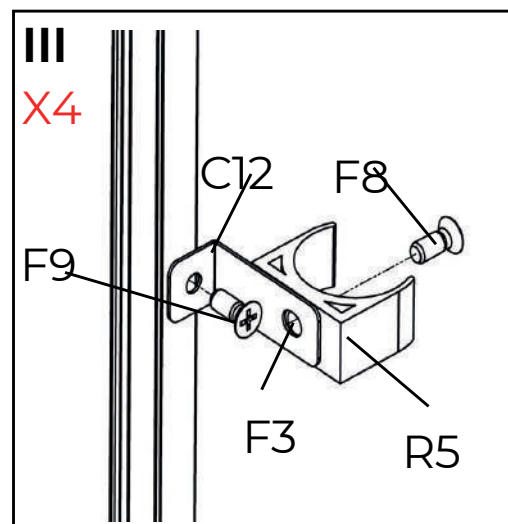
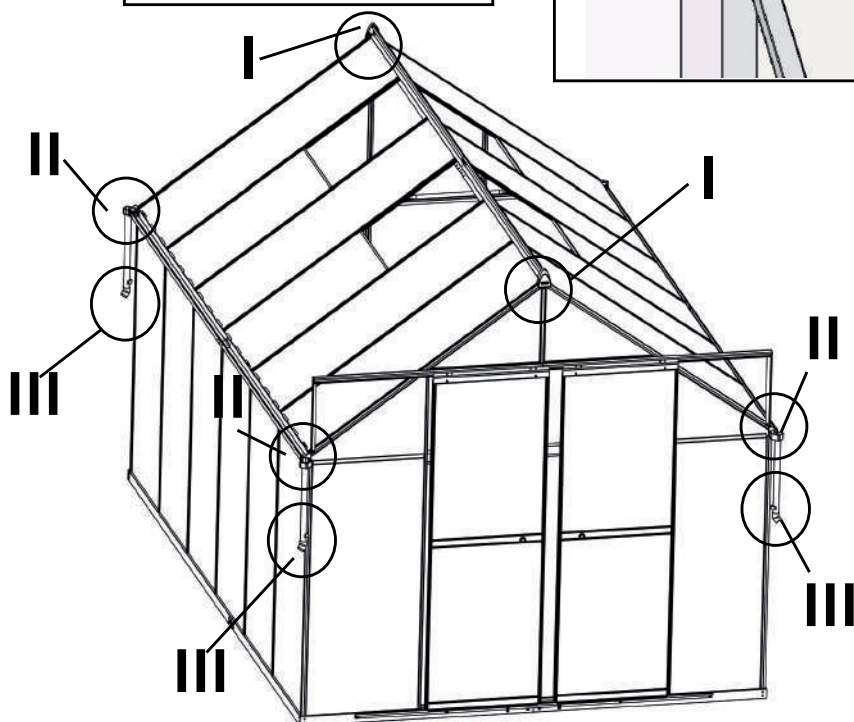
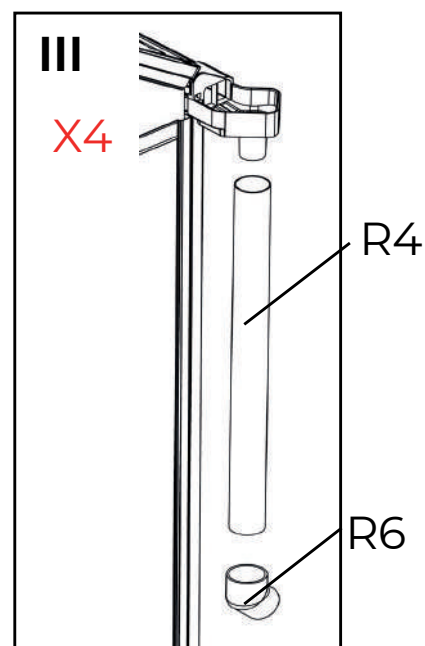
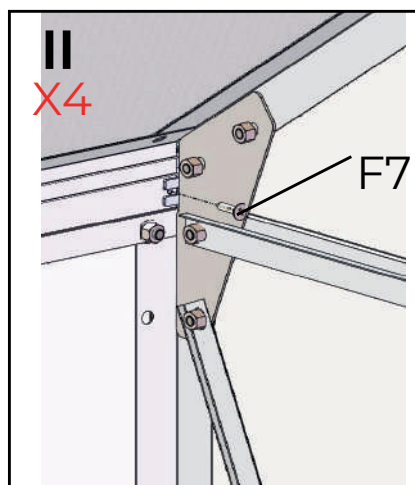
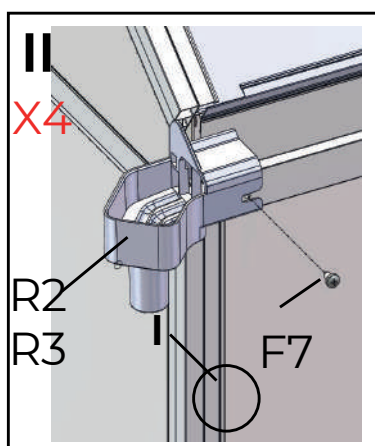
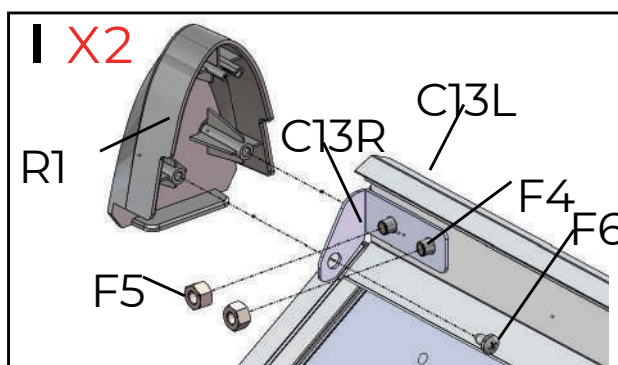
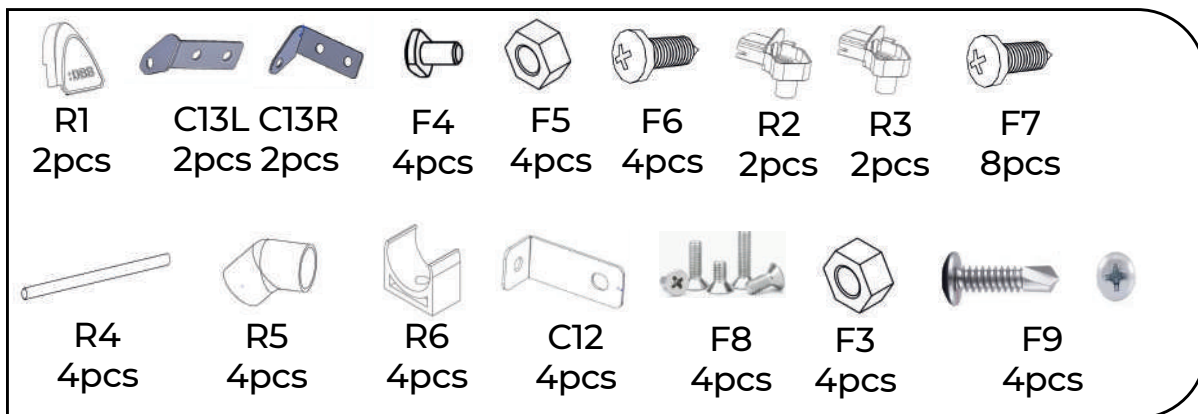

37

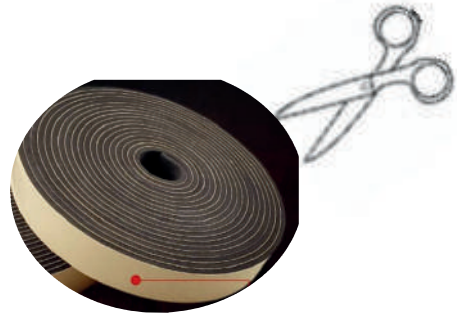
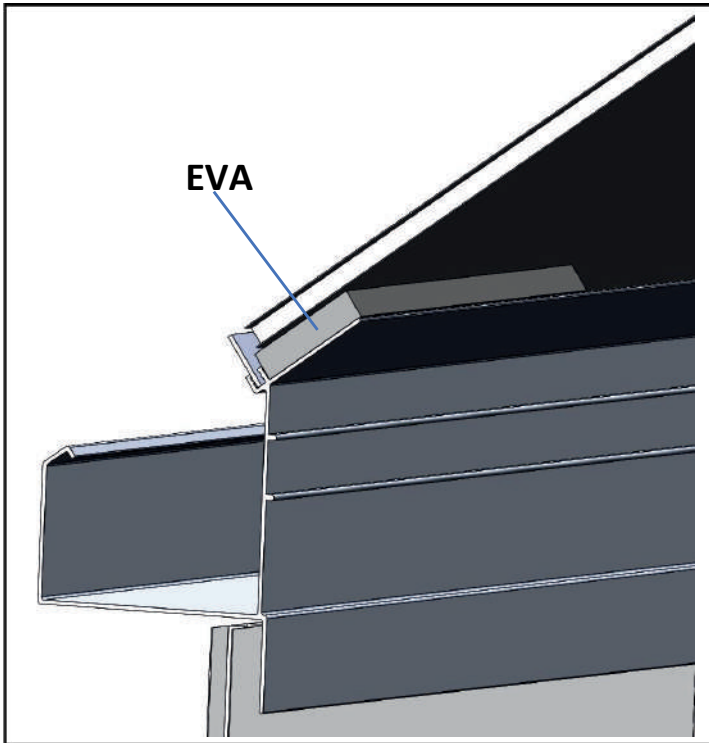
EVA
18m

Uwaga: Użyj paska uszczelniającego EVA po wewnętrznej stronie płytki drukowanej i gniazda aluminiowego.

