

# TOOENJOY

## Instructions

### Roof Cross bar

**304 series**

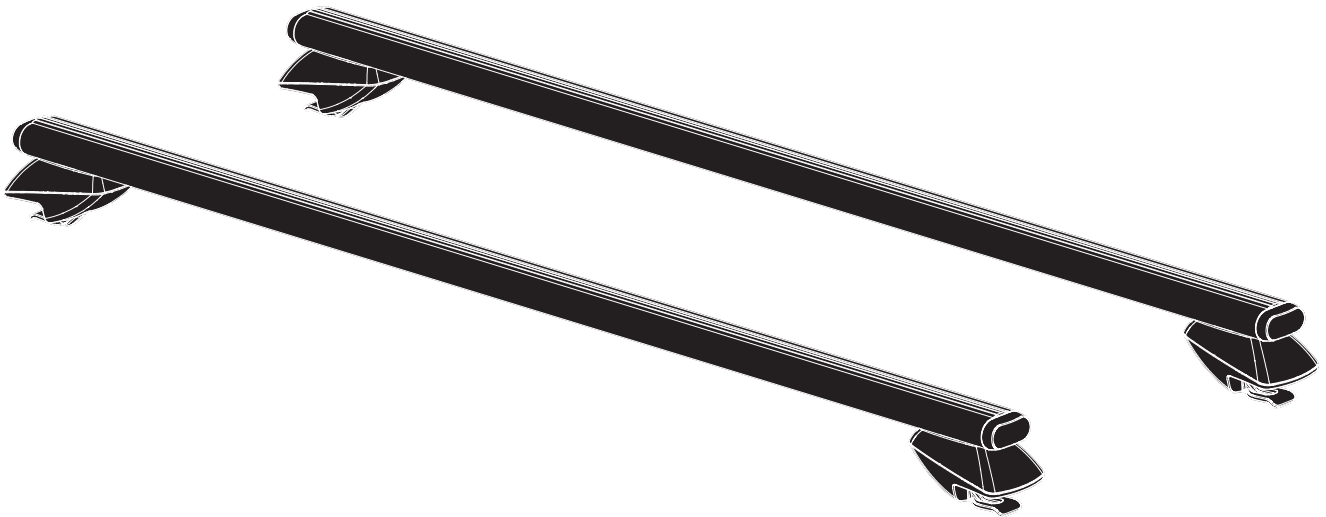

## **A.0 Fitting**

- A.1** Check with the assembly instructions that all the necessary parts are present.
- A.2** Clean the car roof and those parts of the product that come into contact with the roof before and regularly during use.
- A.3** Go through and carefully follow the assembly instructions and the recommendation list, if one is included. Then fit the unit in the correct sequence, that is to say 1, 2, 3 and so on.
- A.4** If no special fitting positions are given in the assembly instructions, try to maintain a minimum distance of 700 mm between the load carrier bars.
- A.5** When carrying long loads, the distance between the load carrier bars should not be less than 600 mm.
- A.6** Every time the unit is fitted, check that the load carrier is sitting securely on the roof. Try to push and pull the carrier out of its locked position. Try also to pull out the tensioning tabs from the roof edge. If you manage to move any part of the unit, the load carrier must be secured more firmly. This test should be carried out regularly.
- A.7** Some types of sunroof and radio antenna cannot be used when the carrier is fitted.
- A.8** The roof rack is permitted to be assembled on cars with glass roof, unless otherwise is specified in mounting instruction.
- A.9** The manufacturer can not be held responsible for personal damages of property or lost of fortune caused by incorrect mounting or use of the product.
- A.10** No modifications to the product are permitted.
- A.11** Consult with your dealer if you have any questions regarding the operations and limits of the products. Review all instructions and warranty information carefully.

## **B.0 Loading**

- B.1** The maximum load specified in the assembly instructions is not to be exceeded. However, this limit is always subordinate to the maximum load recommended by the manufacturer of the car itself. It is always the lower maximum recommended load that applies. Max. roof load = load carrier weight + any fitted carrier accessories + the weight of the load itself.
- B.2** The load may not significantly exceed the load carrier's width, and it should always be spread evenly across the load carrier and with the lowest possible centre of gravity.
- B.3** Maximum load applies to driving as well as parked vehicle.
- B.4** When several surfboards are being carried, they should not be placed beside each other but instead one on top of the other.
- B.5** When carrying surfboards and other long items, these shall be secured both at the front and the rear of the vehicle.
- B.6** Skis must be carried with their pointed ends facing the rear of the vehicle.

- B.7** All loose or removable parts of the load such as bike child seats, tyre pumps, fins and so on should be taken off prior to loading.
- B.8** The load should be thoroughly secured. Elastic bungees are not to be used.
- B.9** The load's security should be checked after a short distance, and thereafter at suitable intervals. Tighten the load's securing straps whenever necessary.

NOTE! Always check the load's attachment security.

## **C.0 Driving properties and regulations**

- C.1** Road speed should always be adjusted to suit the load being carried - and the current driving conditions, such as road type and quality, wind conditions, traffic intensity and applicable speed limits.
- C.2** The vehicle's speed must always be adjusted to the load being carried and the current driving conditions, such as the road type, road quality, wind conditions, traffic intensity and applicable speed limits, but must under no circumstances exceed 130 km/h. Applicable speed limits and other traffic regulations must always be observed.
- C.3** Drive slowly over speed bumps, maximum speed 10 km/h.
- C.4** Note that the vehicle's total height increases when upright loads are carried.
- C.5** The vehicle's driving characteristics and braking behaviour change and its vulnerability to side-winds increases when a load is carried on the roof. rough roads.
- C.6** Products fitted with a lock should always be locked during transport.
- C.7** Off-road driving is only approved for roof rack without load or accessories attached.
- C.8** Adapt your speed to the conditions of the road and load being carried, check tension of load carrier frequently, especially when travelling on

## **D.0 Maintenance**

- D.1** Check and replace worn-out or defective parts.
- D.2** The load carrier should always be cleaned and maintained, especially in the winter.
- D.3** Screws, nuts and locks (if fitted) should be lubricated at regular intervals.
- D.4** When not in use, the product should be removed from the vehicle.
- D.5** When the product is removed from the vehicle, all loose parts should be stored safely.

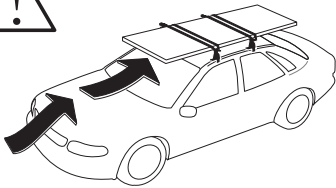
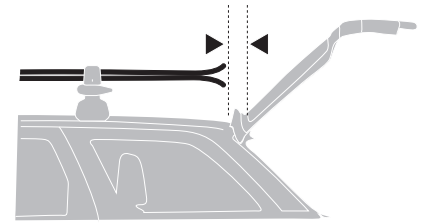
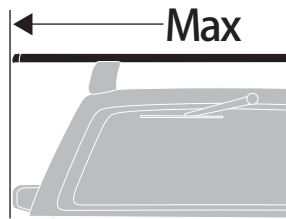
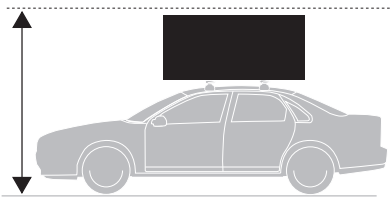
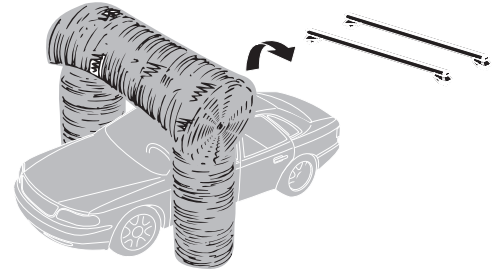
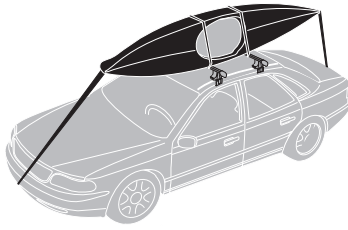
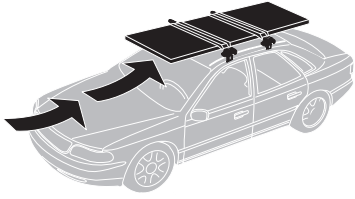

80 km/h  
50 Mph

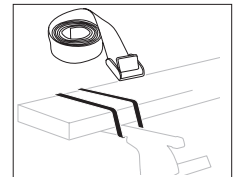
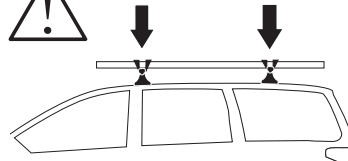
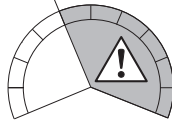

**i**

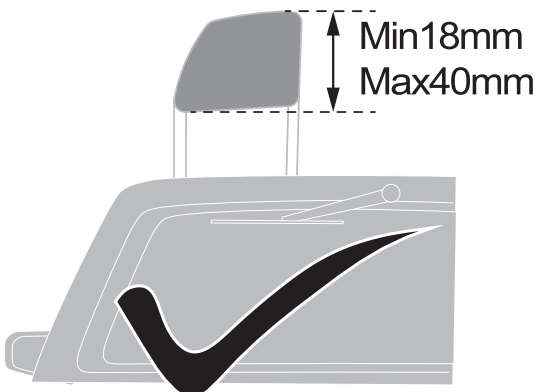

**Separated Rail**

**304 ROOF RACKS**

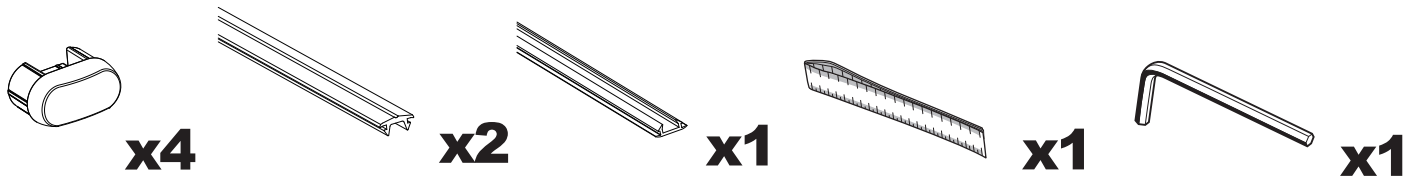
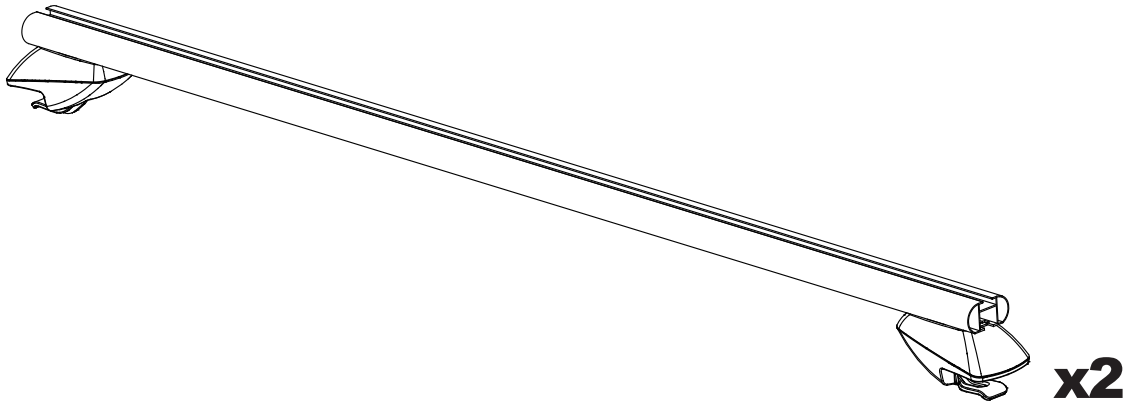

**1**

**A**

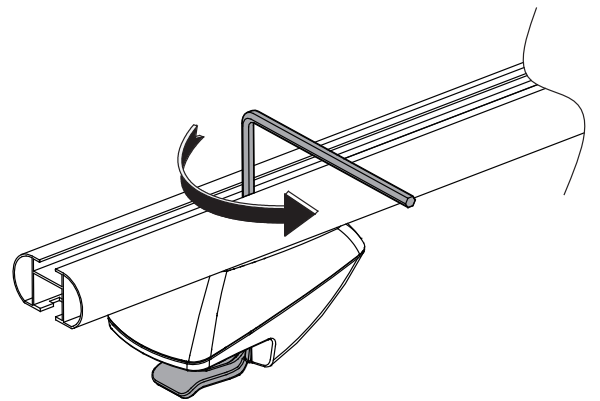
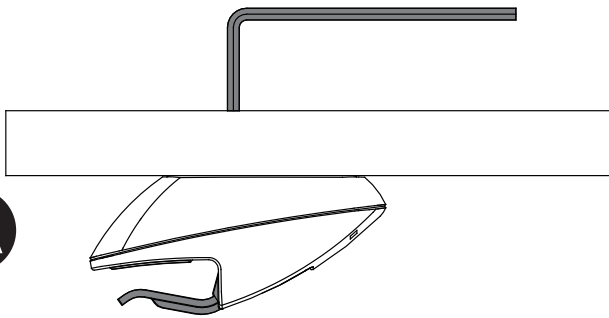

**B**

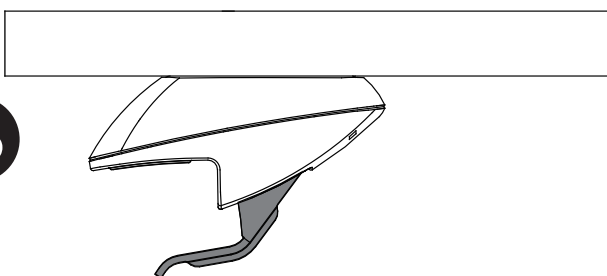

2

A

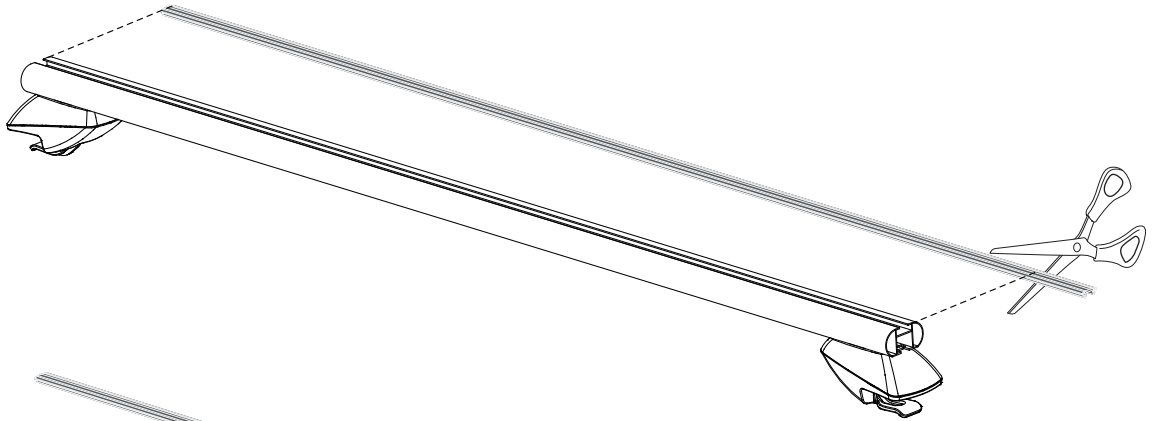

B

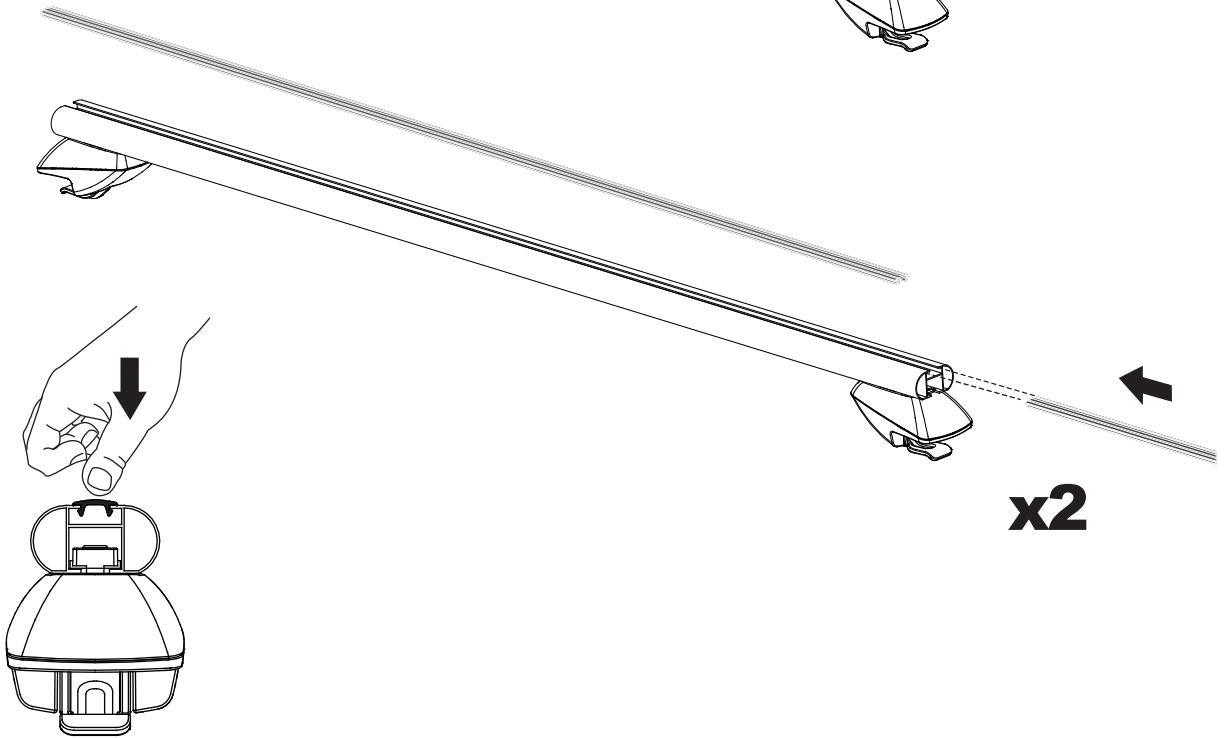

C

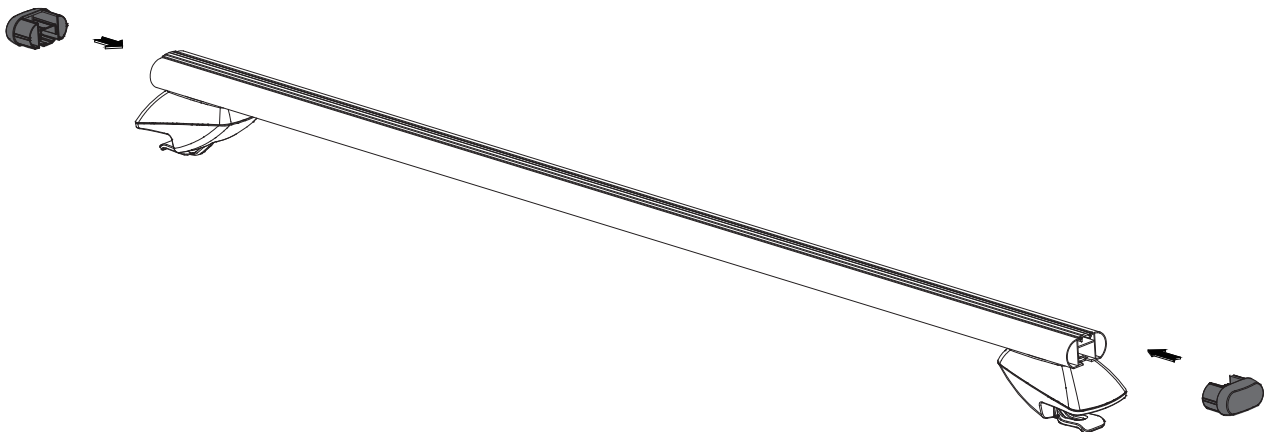

5

**3**

**A**

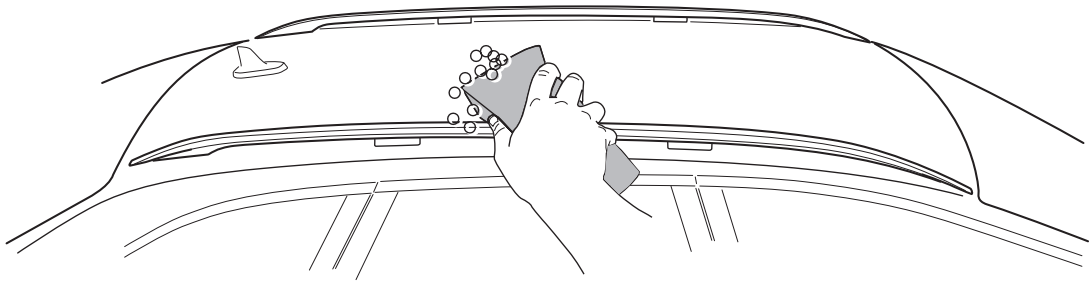

**B**

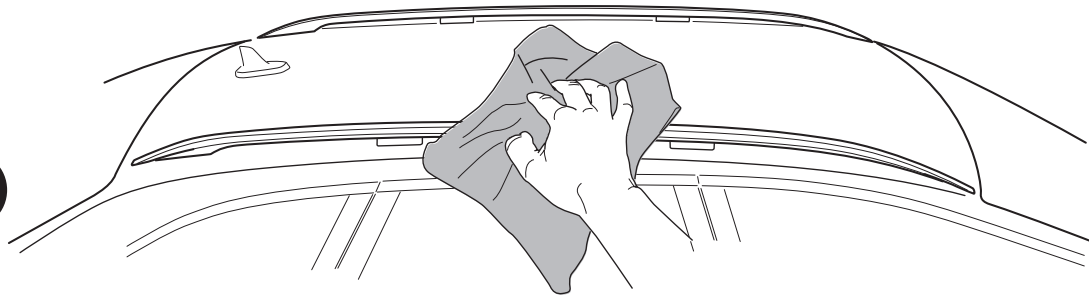

**4**

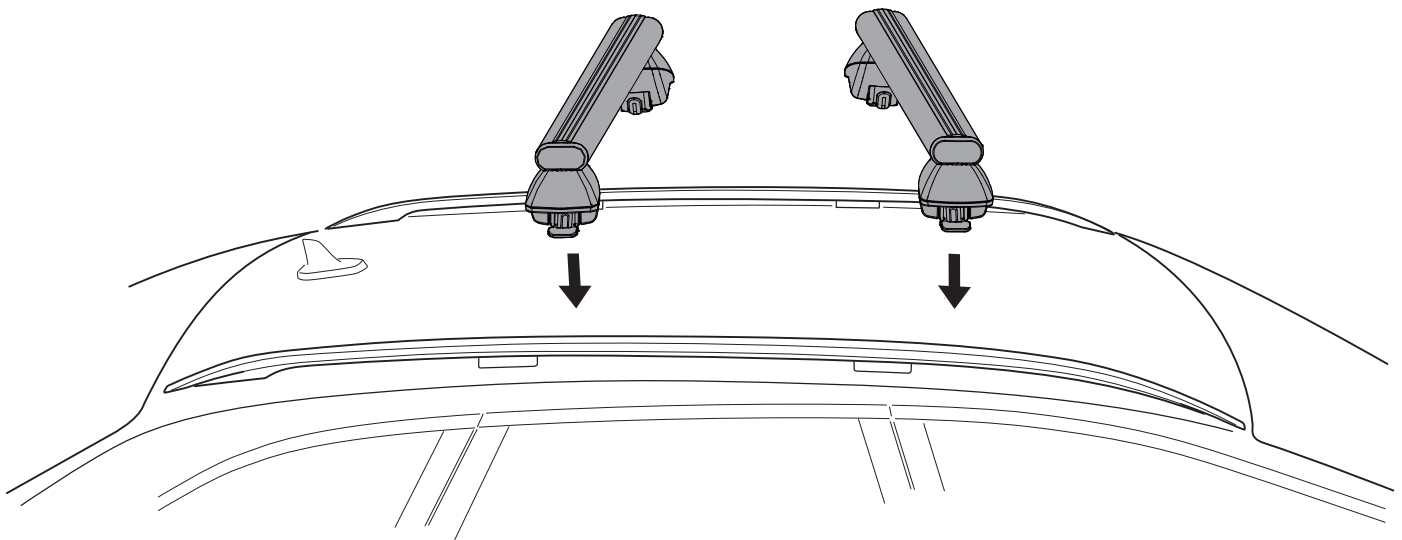

**5**

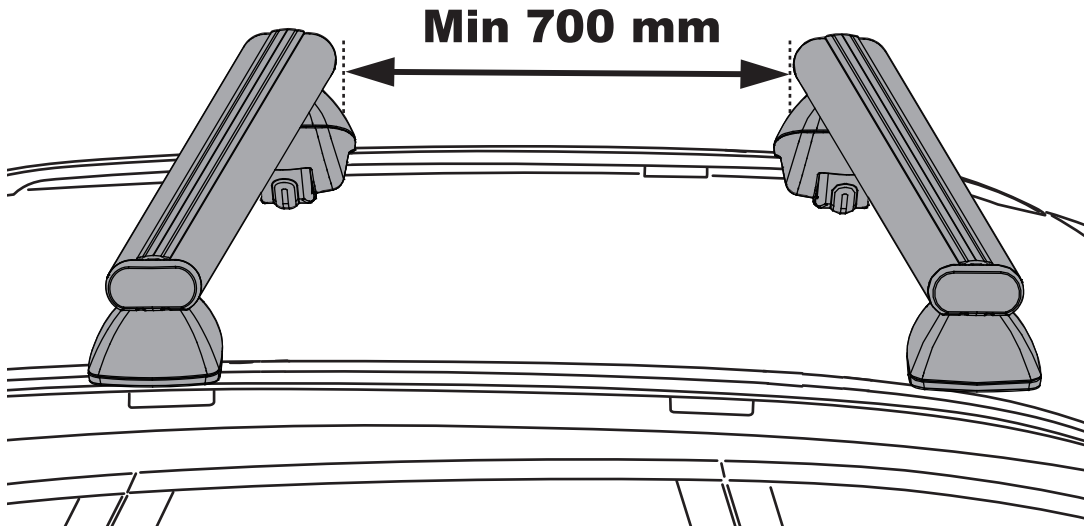

---

**6**

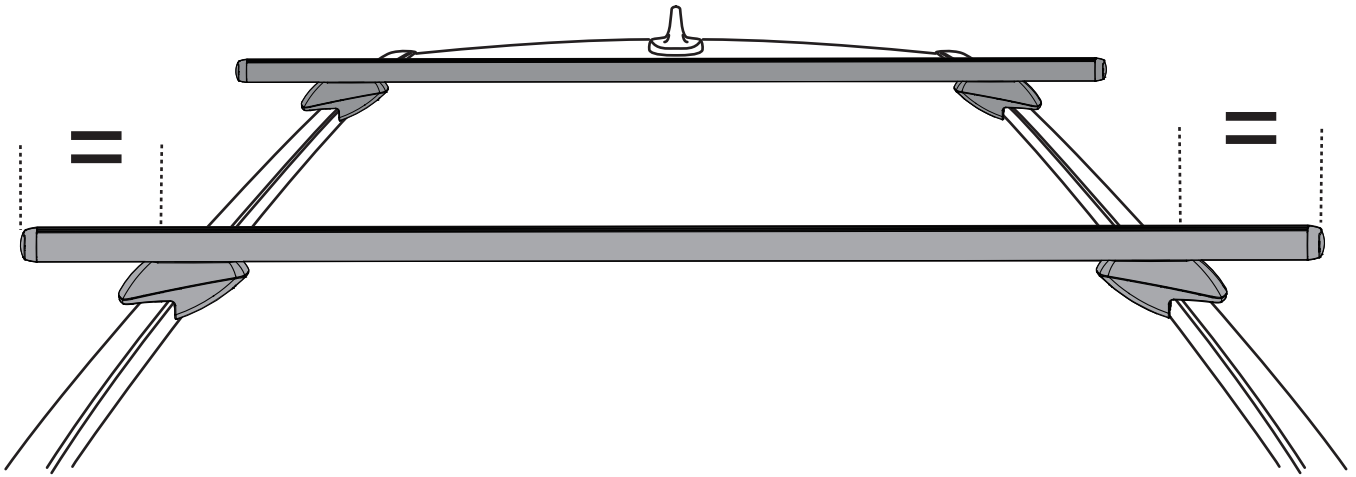

**7**

6

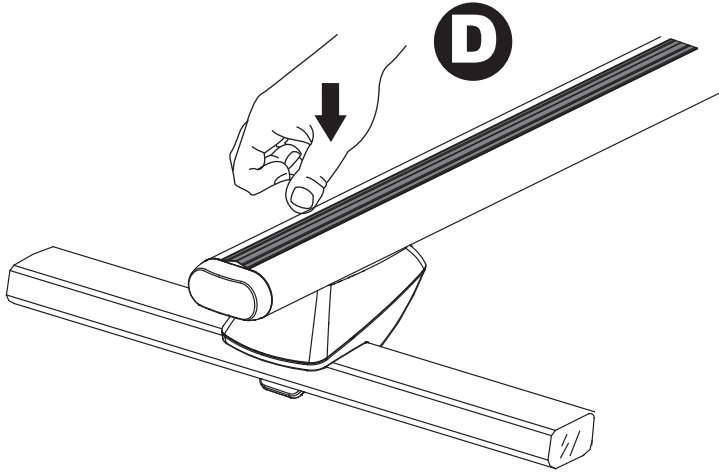
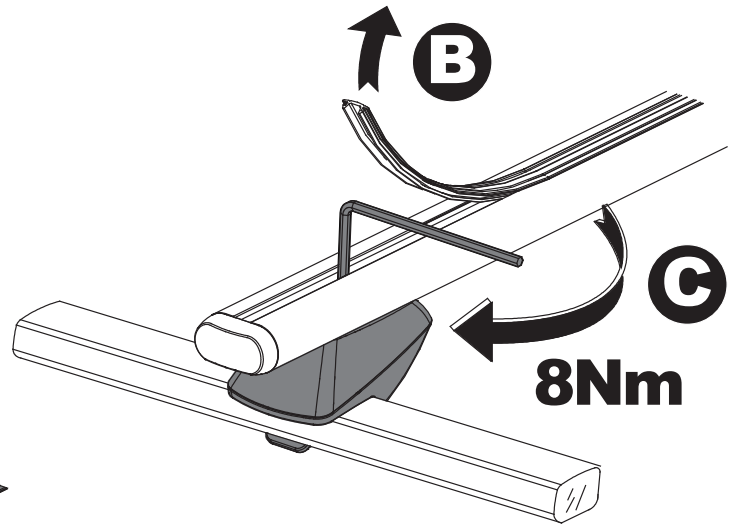
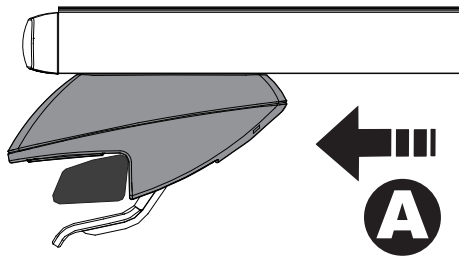

7

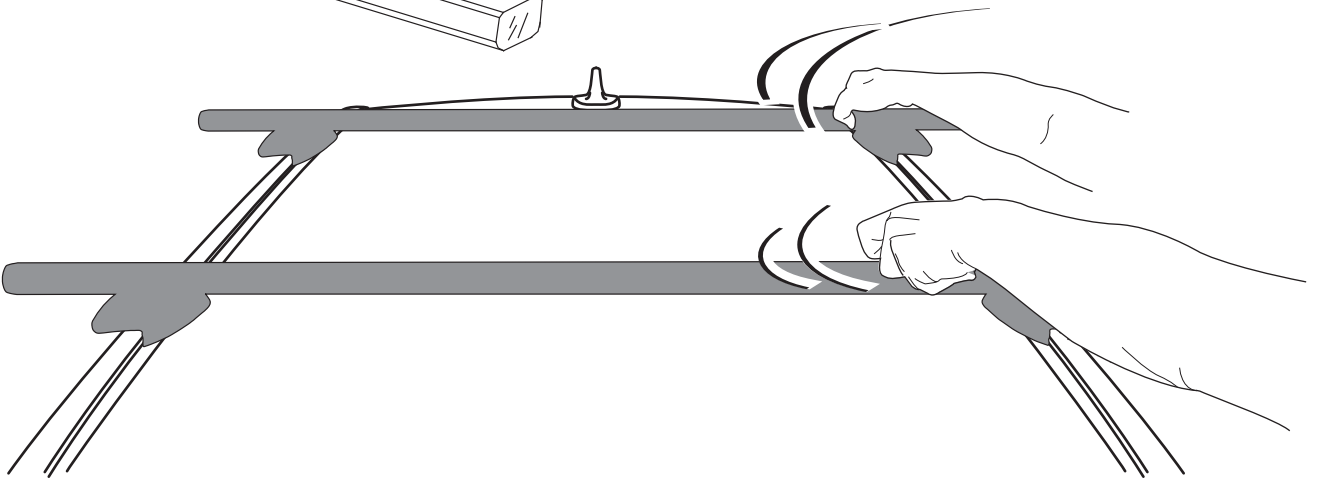

8

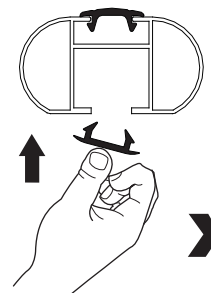
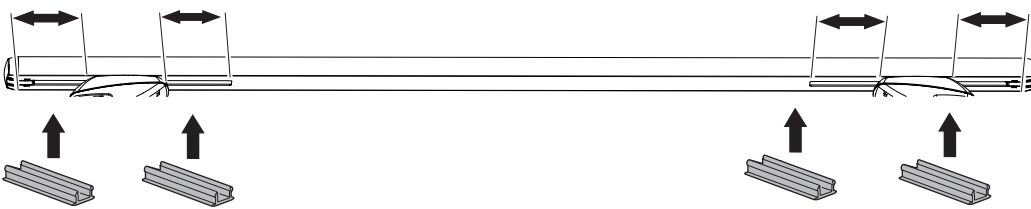
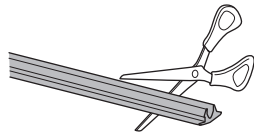

x2

**i**

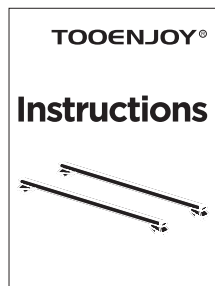
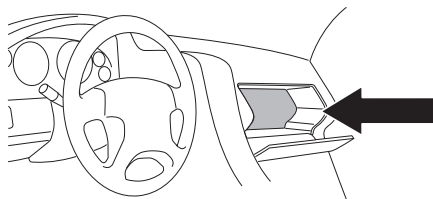
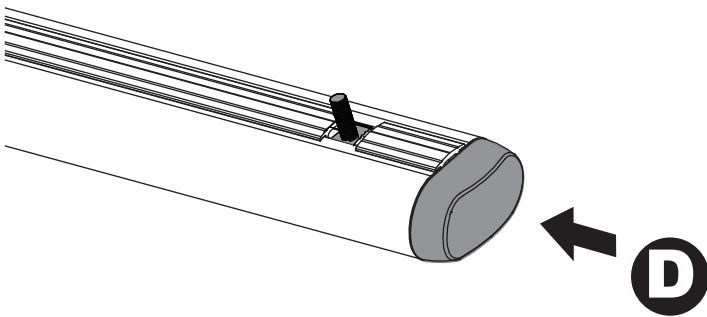
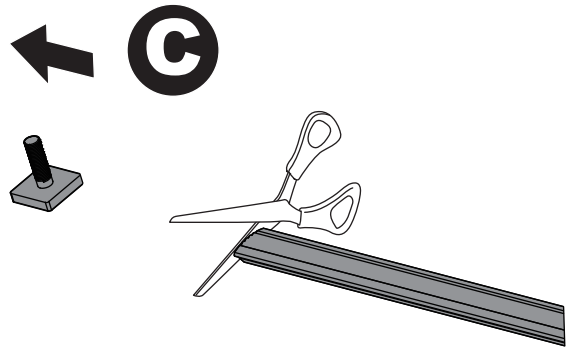
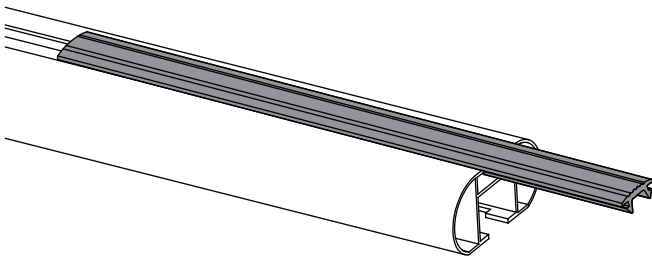
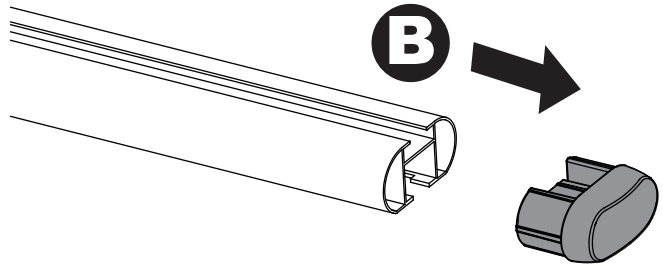
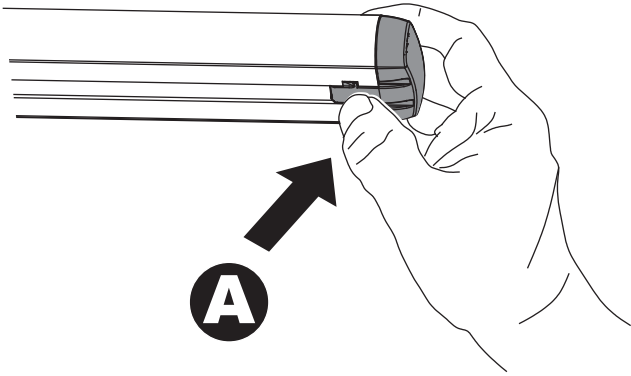
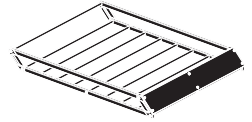

# PART NO.

---

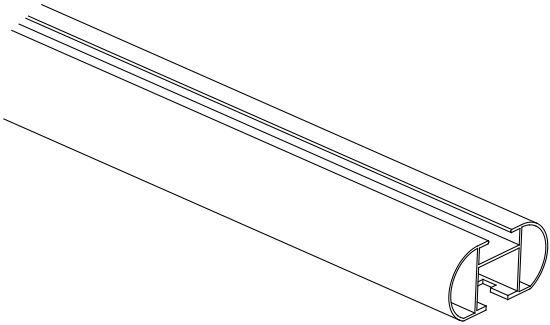

**304L01**

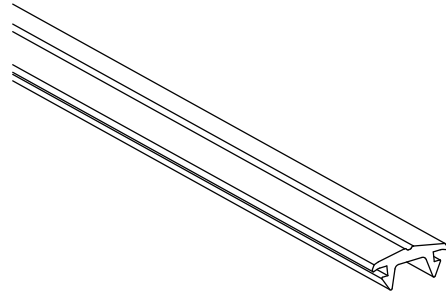

**304S04**

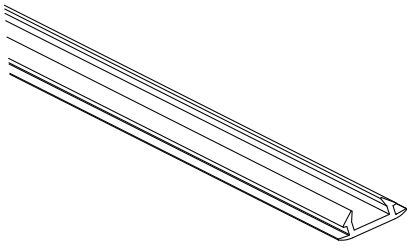

**304S05**

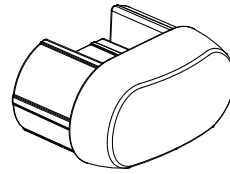

**304S03**

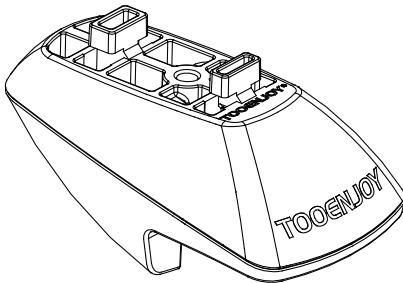

**304S01**

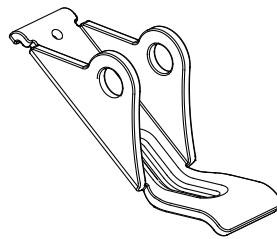

**304T01**

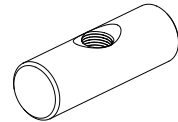

**304T02**

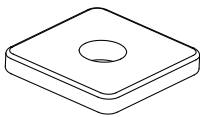

**304T03**

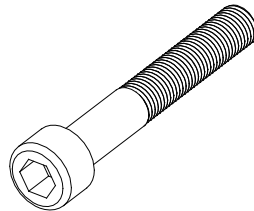

**M640**

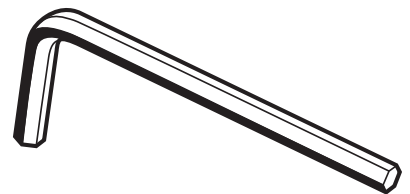

**S560120**

# TOOENJOY

---

 [support@tooenjoymall.com](mailto:support@tooenjoymall.com)

 [www.tooenjoymall.com](http://www.tooenjoymall.com)