

www.aps-company.com



AEON

ACTIVE STUDIO MONITOR

CONTENTS

| | page |
|-------------------------------------|-----------|
| INTRODUCTION | |
| GENERAL INFORMATION | 3 |
| BREAK-IN TIME | 3 |
| | |
| REAR PANEL | |
| REAR PANEL | 4 |
| SWITCHES | 5 |
| | |
| INDICATORS & PROTECTION | |
| INDICATORS | 5 |
| PROTECTION | 5 |
| | |
| SETTING UP & POSITIONING | |
| UNPACKING | 6 |
| POSITIONING | 6 |
| CONNECTING & STARTING | 9 |
| | |
| TECHNICAL SPECIFICATIONS | |
| TECHNICAL SPECIFICATIONS | 10 |
| | |
| SAFETY INSTRUCTIONS | |
| SAFETY INSTRUCTIONS | 11 |
| | |
| MISCELLANEOUS | |
| CARE | 12 |
| BLOCK DIAGRAM | 12 |

INTRODUCTION

Congratulations on your purchase of the APS **AEON** active monitor. **AEON** is designed to provide many years of excellent and trouble free audio reproduction. It is most important, however, that you take a few minutes to read this manual. It contains essential information to make you get the best from your new monitors.

General Information

AEON is a professional studio monitor for near-medium field, designed for accurate sound realization.

This loudspeaker is suitable for:

- recording studios,
- broadcasting studios,
- TV studios,
- multimedia studios,
- post production facilities,
- mastering,
- digital workstations,
- home recording studios,
- audio monitoring systems of the highest quality.

AEON monitor is a two-way active system. It has two independent power amplifiers, mounted on the rear panel, for each: tweeter and bass/mid-range loudspeaker. There are also calibrated controls, protections, indicators, and the input terminals.

AEON is designed for operation in stereophonic or multi-channel systems (5+1 or 7+1 and larger) such as DOLBY, DTS, THX, etc.

Break-In time

The transducers of your APS **AEON** monitor will achieve better sound quality after breaking in. Especially after the first hours of use, you may notice a significant advance in sound quality.



APS Spanily s.j.
Sikorskiego 15
62-020 Swarzędz
POLAND

tel. +48/ 61/ 817 22 82
fax +48/ 61/ 817 22 82
www.aps-company.com
e-mail: info@aps-company.com

REAR PANEL

Correct setup is essential to achieve optimal performance from your monitors. Please follow the instructions on the following pages.

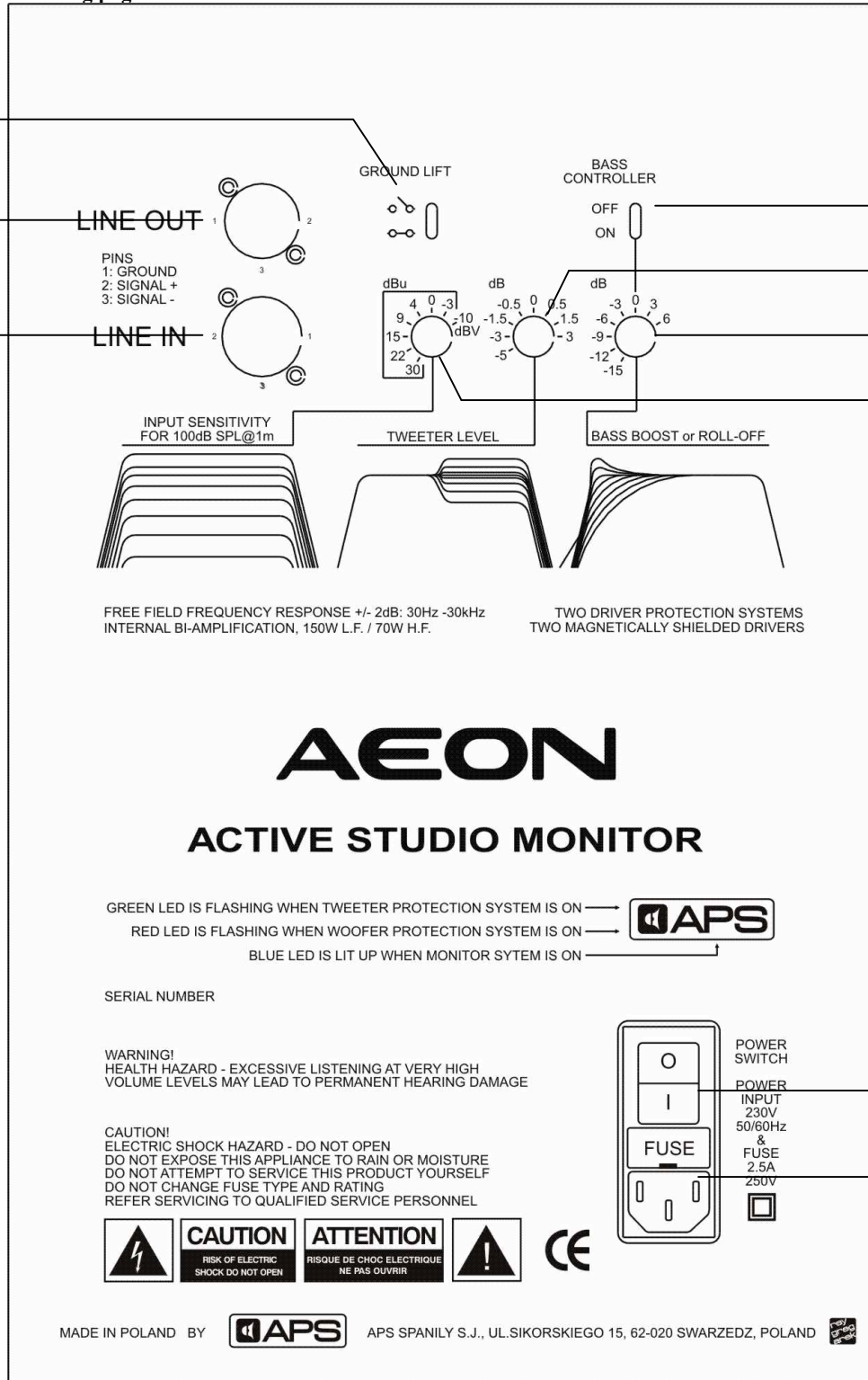

1. AC input and fuse
2. Power on/off switch
3. Input Sensitivity Switch
4. Tweeter Loudspeaker Level Switch
5. Bass Controller Level Switch

6. Bass Controller Switch
7. Ground Lift Switch
8. XLR symmetrical (balanced) output
9. XLR symmetrical (balanced) input

Switches

On the rear of the monitor you will find switches for setting up the monitor for optimum performance in different acoustic and electric environments. Each switch is explained in the following.

3. Input Sensitivity Switch

Use this switch to match the sensitivity of **AEON** monitor to your source.

AEON functions together with the most common signal sources. The step switches allow you to adjust exactly the same levels in each monitor in stereophonic or multi-channel systems.

4. Tweeter Loudspeaker Level Switch

This switch controls the higher tones. You can use it to match **AEON** sound with room conditions, audio monitoring conditions or sound material.

If the surfaces of walls in the room are made of hard and smooth materials, the sound - especially the high frequencies - can be strongly reflected and it will be too bright. In such situation it is recommended to decrease the treble level.

You can also raise the treble if the sound is too dull.

5. Bass Controller Level Switch & 6. Bass Controller Switch

In the case of the monitors arrangement in front of a wall or if the monitor is suited in a corner of the room you should best decrease the level of bass.

If the room is too small it is also advisable to decrease the level of bass by a few dB.

One can always decrease or increase the level of deep bass, depending on a personal taste.

Note: the Bass Controller Level Switch is active when the Bass Controller Switch is adjusted in the on position.

Bass Controller Switch allows you to switch off the Bass Controller decreasing the low bass volume whilst increasing its speed.

7. Ground Lift Switch

It allows disconnection of the ground to the common (common of your studio equipment) if ground loops occur.

In case of a poorly earthed, and/or a great number of devices, say in a sound monitoring room, hums, interferences and other disturbances can appear. The switch should then be adjusted in such position in which interferences do not appear, or are the lowest.

INDICATORS & PROTECTION

Indicators

On the front you will find Three-Color LED Indicator positioned just underneath the APS logo. The blue power LED indicates speaker on/off status.

The LED indicator flashes green when the input signal reaches a level where the limiter is activated to prevent the internal high frequency amplifier from clipping and the tweeter from damage as well.

The LED indicator flashes red when the input signal reaches a level where the limiter is activated to prevent the internal bass amplifier from clipping and the woofer from damage as well.

Protection

AEON monitor has several built in protection systems to reduce the risk of hazard or damage due to overloading as well as prevent against interferences.

The tweeter is protected by an electronic Tweeter Protection System limiting overdrive of its dedicated Power Amplifier. The Tweeter Power Amplifier is equipped with thermal, short circuit and over-current protections. There are also interference eliminators operating during switch-on and switch-off.

The woofer is similarly protected by its own Woofer Protection System. The woofer section is also equipped with its own thermal sensor and is protected by a specially designed Power Amplifier Controller.

The **AEON** loudspeakers are magnetically shielded, preventing interferences with TV screen, computer monitor screen (e.g. disturbance of colors) or other equipment standing nearby.

There is also the Ground Lift Switch preventing against ground loops.

SETTING UP & POSITIONING

Unpacking

OK, first things first:

Prepare adequate space before taking the monitor out of the package to avoid the necessity of a hasty search for a "piece" of table, chair or floor with your **AEON** in hand.

It is necessary to exercise caution while unpacking the device in order to avoid damage to the Bass/Mid-Range and Tweeter Loudspeaker diaphragms as well as the switches mounted on the rear panel of the monitor.

Positioning

Step 1

Prepare a suitable place for each **AEON** monitor. They can be special supports or fastenings or also other stable stands, pedestals, shelves or areas located in audio monitoring places.

Remark 1

The location of your monitors depends on the system: stereophonic or multi-channel systems (5+1 or 7+1 and larger).

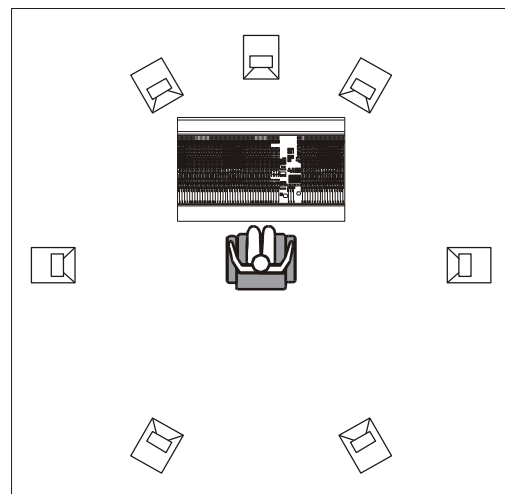
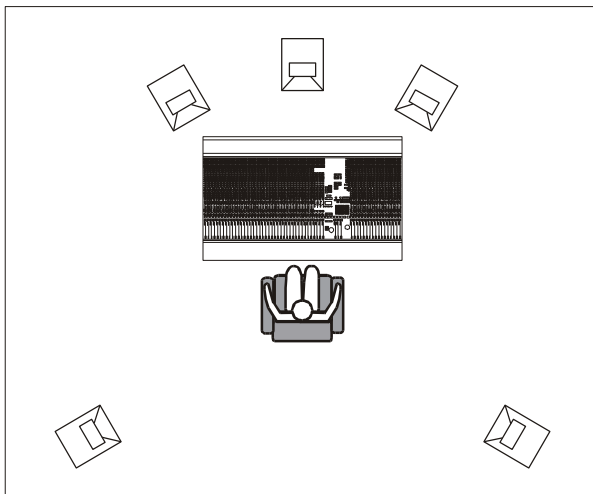

Remark 2

For stereo, the angle between the lines connecting the listener's face with the left and right monitor should amount to about 60°, while the distance from each monitor should be equal.

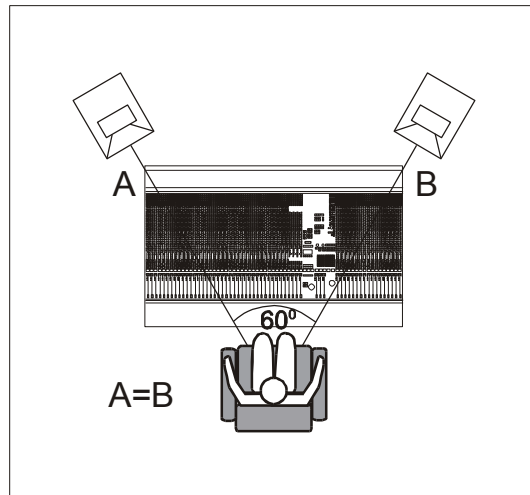

Step 2

Install the Stick-On Feet in suitable places of the monitor base near the corners to ensure its stability.

Step 3

Put monitors in a vertical position – standing up, (although horizontal position - lying down - is also permissible), so that the center (Tweeter Loudspeaker axis) will be located at the ear-level of the listener.

Step 4

Turn each monitor so that the Tweeter Loudspeaker will be turned in the direction of the listener.

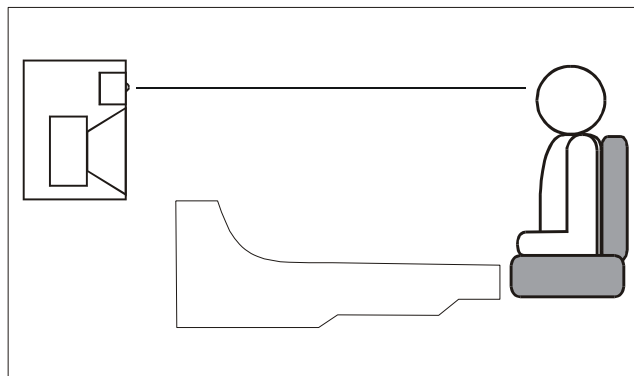

Remark 3

The monitors can also be situated above the ear-level. In this case, it is necessary to tilt them so that the Tweeter Loudspeaker will be turned towards the listener.

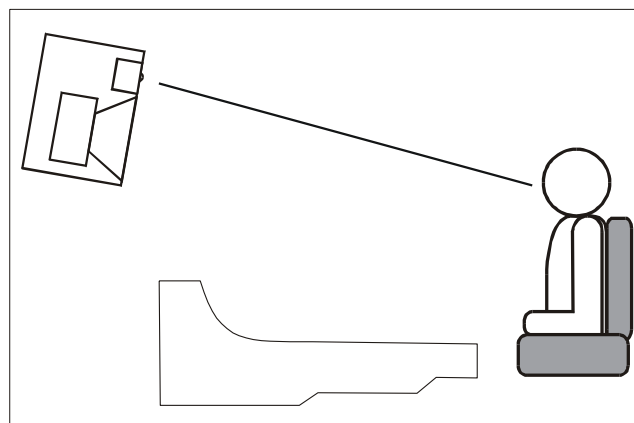

Remark 4

It is necessary to match the location of the monitor, the listener's head and reflecting surfaces (e.g. mixer console surface) to avoid a situation in which the reflected sound directly reaches the listener's ears.

Illustrating: it is best to choose such a location for the monitors so that they will not be visible in a mirror put on the mixer console halfway between the listener's face and each monitor.

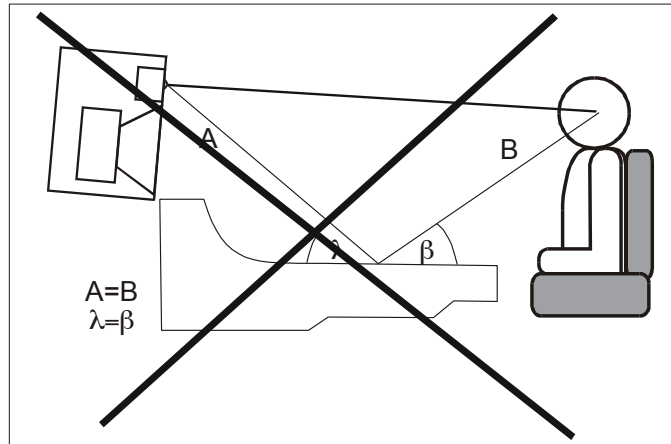

Remark 5

The most favorable is a configuration which allows similar acoustic conditions for each channel, e.g. the same distances of the left and right monitor from walls (from side, in the back of monitors), the same distances of the listeners ears from walls.

Remark 6

It is worth placing the **AEON** away from walls, especially corners; even though the wide range of precise control settings allows the monitors to work in practically any position.

Remark 7

It is necessary to allow some air flow behind **AEON**. In particular, do not put the monitor on a closed shelf or cover the rear panel of the monitor with materials blocking dispersion of heat, e.g. sound absorbing materials, curtains, etc.

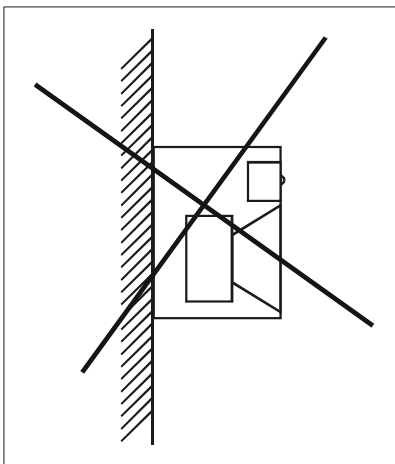

Connecting and Starting

Step 1

Adjust all regulators in 0 dBu and 0 dB positions before connecting.

Step 2

Adjust output level of signal source in the minimum position.

Remark 1

If a value of source output level is not known, then the safest method is to adjust the Input Sensitivity Switch in 30 dBu position.

Step 3

Bass Controller Switch should be adjusted in the switch-on position, with GROUND LIFT Switch in the switch-off position.

Step 4

Adjust the Power Switch adjustment in the switch-off position.

Step 5

Put XLR connector of the cable connected to symmetrical signal source (e.g. mixer console) into the XLR Symmetrical Input of **AEON**.

Remark 2

It is possible to make use of the Big Jack Symmetrical Input using the big jack symmetrical connector or other applying a suitable inter-connector.

Remark 3

It is also possible to connect your **AEON** monitor to an asymmetrical signal source. In this case one should use a suitable inter-connector, whose connection diagrams are shown below (RCA and XLR standards).



Connection in case of cable – two wires in screen

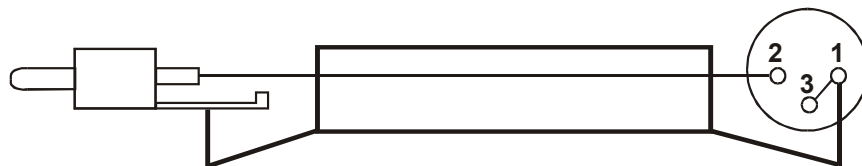

Connection in case of cable having one wire in screen

Remark 4

The use of high quality signal connectors and cables is recommended. Solid signal connectors are a must if you want to get the best sound performance.

Step 6

Connect the power cable to the Power Cable Socket and switch on power by means of **AEON** Power Switch.

Remark 5

Connecting your monitors via computer power cords is not recommended. Similarly don't use low quality power conditioners, etc. Using the power conditioners is not required.

Remark 6

Power cables of the monitor and a signal source connect best to the same power sockets unit.

Step 7

Adjust suitable source (e.g. mixer console) output level slowly.

Remark 7

Change the level by means of Input Sensitivity Switch especially if it was adjusted in 30 dBu position.

TECHNICAL SPECIFICATIONS

| AEON Active Studio Monitor | |
|---|--|
| Field Monitor | Near-medium |
| Type | Active – two power amplifiers: - Tweeter p.a.: monolithic integrated circuit TDA7294 - Woofer p.a. operates on 2SA1943/2SC5200 |
| System | Two-way |
| Crossover Frequency | 1.5 kHz (slope: 24 dB/octave.) |
| Dimensions: Height × Width × Depth | 42 cm × 27 cm × 36 cm/ 16.5" x 10.5" x 14" |
| Free Field Frequency Response | ± 2 dB: 30 Hz ÷ 30 kHz |
| SPL in Free Field @ 1m | RMS: 108 dB Peak: 116 dB |
| Weight | 18 kg / 39.6 lbs. |
| Loudspeakers | |
| Bass/Mid-Range Loudspeaker | φ 22 cm (8 2/3") Diaphragm: cellulose, surround: rubber Magnetically shielded |
| Tweeter Loudspeaker | φ 2.5 cm (1") in two versions: - Fabric dome - Titanium dome Magnetically shielded |
| Amplifiers | |
| Bass/Mid-Range Power Amplifier | 150 W RMS @ 4 Ω |
| Tweeter Power Amplifier | 70 W RMS @ 6 Ω |
| THD Distortions | 0.005 % – P _O = 5 W, f = 1 kHz 0.1 % max – P _O = 0.1 up to 50 W, f = 20 Hz up to 20 kHz |
| Signal to Noise Ratio | 103.5 dB – weighted by A curve 101 dB – in band of 20 Hz up to 20 kHz |
| Input Voltage Level for 100 dB SPL In Free Field @ 1m | 0 dBu (i.e. 0.775 V) – calibrated regulators in 0 dBu, 0 dB positions |
| Calibrated Controls | |
| Input Sensitivity Switch | 30dBu, 22dBu, 15dBu, 9dBu, 4dBu, 0dBu, -3dBu, -10dBV |
| Bass Controller Level Switch | -15dB, -12dB, -9dB, -6dB, -3dB, 0dB, 3dB, 6dB |

| | |
|--|--|
| Bass Controller Switch | Position ON: bass-reflex with active filter Position OFF: "clear" quick bass-reflex |
| Tweeter Loudspeaker Level Switch | -5dB, -3dB, -1.5dB, -0.5dB, 0dB, 0.5dB, 1.5dB, 3dB |
| Inputs, Outputs | |
| Input | Two types (common socket Combo): - XLR symmetrical (balanced) - TRS symmetrical (balanced) "6.3 mm" Input impedance 10 k Ω |
| „Loop Through" Output | XLR symmetrical Output impedance 100 Ω |
| Protections | |
| Tweeter Loudspeaker Protection | Limiter (optical) |
| Bass/Mid-Range Loudspeaker Protection | Limiter (optical) |
| Power Amplifiers Protections | Interference, thermal, short circuit and over-current limiters |
| Prevention from Interferences and Hums | GROUND LIFT switch |
| Signaling Devices | |
| Tweeter Loudspeaker Protection Switching On | Lit up logo – green LED |
| Bass/Mid-Range Loudspeaker Protection Switching On | Lit up logo – red LED |
| Power Switching On | Lit up logo – blue LED |

SAFETY INSTRUCTIONS



The lightning flash with an arrowhead symbol within an equilateral triangle, is intended to alert the user to the presence of uninsulated "dangerous voltage" within the product's enclosure that may be of sufficient magnitude to constitute a risk of electric shock to persons.



The exclamation point within an equilateral triangle is intended to alert the user to the presence of important operating and maintenance (servicing) instructions in the literature accompanying the product.

1. Read these instructions.
2. Keep these instructions.
3. Heed all warnings.
4. Follow all instructions.
5. Do not use this apparatus near water.
6. Clean only with dry cloth.
7. Install in accordance with the manufacturer's instructions.
8. Do not install near any heat sources such as radiators, heat registers, stoves, or other apparatus (including amplifiers) that produce heat.
9. Do not defeat the safety purpose of the polarized or grounding-type plug. A polarized plug has two blades with one wider than the other. A grounding type plug has two blades and a third grounding prong. The wide blade or the third prong are provided for your safety. If the provided plug does not fit into your outlet, consult an electrician for replacement of the obsolete outlet.
10. Protect the power cord from being walked on or pinched particularly at plugs, convenience receptacles, and the point where they exit from the apparatus.
11. Only use attachments/accessories specified by the manufacturer.

12. Use only with the cart, stand, tripod, bracket, or table specified by the manufacturer, or sold with the apparatus. When a cart is used, use caution when moving the cart/apparatus combination to avoid injury from tip-over.
13. Unplug this apparatus during lightning storms or when unused for long periods of time.
14. Refer all servicing to qualified service personnel. Servicing is required when the apparatus has been damaged in any way, such as power-supply cord or plug is damaged, liquid has been spilled or objects have fallen into the apparatus, the apparatus has been exposed to rain or moisture, does not operate normally, or has been dropped.

Warning!

- ⇒ To reduce the risk of fire or electrical shock, do not expose this equipment to dripping or splashing and ensure that no objects filled with liquids, such as vases, are placed on the equipment.
- ⇒ This apparatus must be earthed.
- ⇒ Use a three wire grounding type line cord like the one supplied with the product.
- ⇒ Be advised that different operating voltages require the use of different types of line cord and attachment plugs.
- ⇒ Always observe the local safety regulations. Ensure that the factory-set power requirements for the device (refer to the label on the back of the monitor) corresponds to the mains supply in your region.
- ⇒ This equipment should be installed near the socket outlet and disconnection of the device should be easily accessible.
- ⇒ To completely disconnect from AC mains, disconnect the power supply cord from the AC receptacle.
- ⇒ The mains plug of the power supply shall remain readily operable.
- ⇒ Do not install in a confined space.
- ⇒ Do not open the unit-risk of electric shock inside.

MISCELLANEOUS

Care

Components of the highest quality are used in your **AEON** monitor. This assures years of trouble free operation. Following precautions should still be made though. Avoid running the system into severe clipping. Even there is an advanced protection system, you may be able to destroy your speakers by severe overpowering. The limiter works over a certain range, but exceeding this level may send a severely clipped signal to your drivers.

When a noticeable distortion occurs, please turn down the level to your speakers. Avoid hot plugging the equipment connected to the monitors. Always turn off the speaker and other equipment when plugging or unplugging signals, or switching equipment on or off.

Do not touch the drive units by hand.

Block Diagram of **AEON** active studio monitor

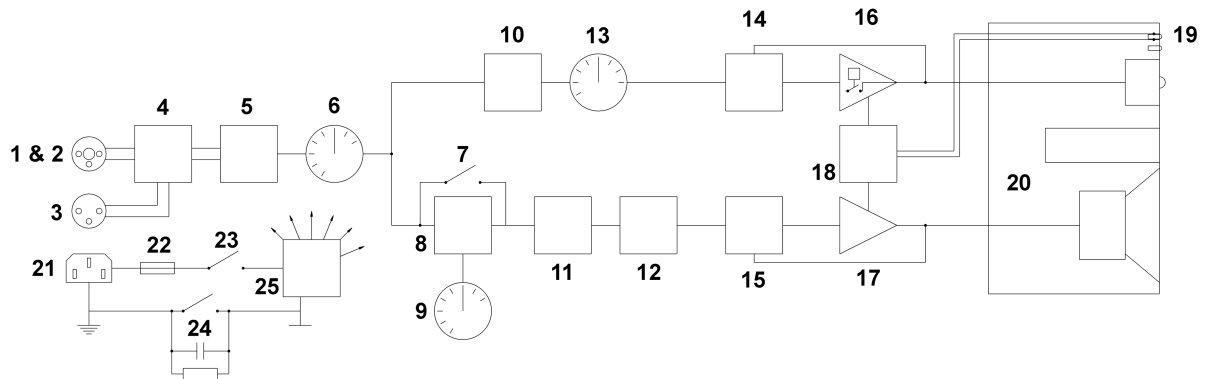

- 1 & 2 – Combo Symmetrical Input (Big Jack & XLR)
- 3 – XLR Symmetrical Output
- 4, 5 – Input Circuit with Symmetrical, Differential Amplifier
- 6 – Input Sensitivity Switch
- 7 – Bass Controller Switch
- 8 – Bass Controller
- 9 – Bass Controller Level Switch
- 10 – Active Crossover Network – High Frequency Circuit
- 11 – Active Crossover Network – Bass/Mid-Frequency Circuit
- 12 – Equalizer – Bass/Mid-Frequency Circuit
- 13 – Tweeter Loudspeaker Level Switch
- 14 – Tweeter Protection System – Limiter
- 15 – Bass/Mid-Range Protection System - Limiter
- 16 – Tweeter Power Amplifier with Protection Circuits controlled by Power Amplifier Controller
- 17 – Bass/Mid-Range Power Amplifier controlled and protected by Power Amplifier Controller
- 18 – Power Amplifier Controller
- 19 – Two-Color LED Indicator – Power Amplifiers Clipping Indicator
- 20 – Loudspeaker System
- 21 – Power Cable Socket
- 22 – Power Fuse
- 23 – Power Switch
- 24 – GROUND LIFT Switch
- 25 – Power Supply Unit