

RAMKRISHNA FORGINGS LIMITED

Date: 7 June, 2022

To The Listing Department BSE Limited PJ Towers Dalal Street Mumbai - 400 001 BSE SCRIP CODE: 532527	To The Listing Department National Stock Exchange of India Limited "Exchange Plaza" C-1, Block G Bandra- Kurla Complex, Bandra (E) Mumbai- 400051 NSE SYMBOL: RKFORGE
---	---

Dear Sir/Madam,

Sub: Disclosure under Regulation 30 of the SEBI (Listing Obligations and Disclosure Requirements) Regulations, 2015 - Presentation for Analysts/Institutional Investors Meetings

In terms of Regulation 30 and other applicable provisions of the SEBI (Listing Obligations and Disclosure Requirements) Regulations, 2015, as amended, we hereby wish to submit a copy of the Investor Presentation of the Company.

The same is also being made available on the website of the Company at www.ramkrishnaforgings.com.

We request you to take the aforementioned information on record and oblige.

Thanking You.

Yours truly,

For Ramkrishna Forgings Limited

Rajesh Mundhra
Company Secretary & Compliance Officer
ACS 12991



REGISTERED & CORPORATE OFFICE

23 CIRCUS AVENUE, KOLKATA 700017, WEST BENGAL, INDIA

PHONE : (+91 33)4082 0900 / 7122 0900, FAX : (+91 33)4082 0998 / 7122 0998, EMAIL : info@ramkrishnaforgings.com, WEB : www.ramkrishnaforgings.com

CIN NO. : L74210WB1981PLC034281



Corporate Presentation

June 2022



**RAMKRISHNA
FORGINGS
LIMITED**

Important Notice:

THIS PRESENTATION IS NOT AN OFFER TO SELL ANY SECURITIES OR A SOLICITATION TO BUY ANY SECURITIES OF RAMKRISHNA FORGINGS LIMITED (THE "COMPANY or RKFL") OR ITS SUBSIDIARIES, TOGETHER WITH THE COMPANY, THE "GROUP"

The material that follows is a presentation of general background information about the Company's activities as at the date of the presentation or as otherwise indicated. It is information given in summary form and does not purport to be complete and it cannot be guaranteed that such information is true and accurate. This presentation has been prepared by and is the sole responsibility of the Company.

This presentation is for general information purposes only and should not be considered as a recommendation that any investor should subscribe to or purchase the Company's equity shares or other securities.

This presentation includes statements that are, or may be deemed to be, "forward looking statements". These forward-looking statements can be identified by the use of forward-looking terminology, including the terms "believes", "estimates", "anticipates", "projects", "expects", "intends", "may", "will", "or" or, in each case, their negative or other variations or comparable terminology, or by discussions of strategy, plans, aims, objectives, goals, future events or intentions. These forward-looking statements include all matters that are not historical facts. They appear in a number of places throughout this presentation and include statements regarding the Company's intentions, beliefs or current expectations concerning, amongst other things, its results or operations, financial condition, liquidity, prospects, growth, strategies and the industry in which the Company operates. By their nature, forward looking statements involve risks and uncertainties because they relate to events and depend on circumstances that may or may not occur in the future. Important factors that could cause our actual results, performances and achievements to be materially different from any of the forward-looking statements include, among others:

- if we are unable to manage any adverse effects of COVID-19 on our business;
- concentration of revenue amongst a limited number of customers and a decline in revenue from those customers;
- changes in requirements of OEM/Tier-1 automotive or other customers that are unfavourable to us;
- reduction in our sales on account of intense competition, downturns in the commercial vehicle industry or damage to our reputation;
- if we are unable to reduce costs or increase prices as needed;
- failure of suppliers to deliver necessary raw materials of appropriate quality and in a timely manner;
- failure to retain or recruit contract workers and employees, particularly skilled workers and senior management at reasonable rates;
- failure to meet performance requirements and any subsequent civil claims or costs incurred from product recalls or cancellation of orders;

- restrictive covenants in our financing agreements limiting our operations and financial flexibility;
- failure to execute our strategies;
- failure to achieve the targeted returns on our investments in increasing our installed manufacturing capacity;
- shortfall in our expectations with regard to the acquisition of other companies or growth in our investments in certain markets, products and product lines; and
- failure to realise payments from our customers in a timely manner.

Forward looking statements are not guarantees of future performance including those relating to general business plans and strategy of the Company, its future outlook and growth prospects, and future developments in its businesses and its competitive and regulatory environment. No representation, warranty or undertaking, express or implied, is made or assurance given that such statements, views, projections or forecasts, if any, are correct or that the objectives of the Company will be achieved.

The Company, makes no representation or warranty, express or implied, as to, and does not accept any responsibility or liability with respect to, the fairness, accuracy, completeness or correctness of any information or opinions contained herein. . The Company assumes no responsibility to publicly amend, modify or revise any forward-looking statements, on the basis of any subsequent development, information or events, or otherwise. Unless otherwise stated in this presentation, the information contained herein is based on management information and estimates. The information contained herein is subject to change without notice and past performance is not indicative of future results. The Company may alter, modify or otherwise change in any manner the content of this presentation without obligation to notify any person of such revision or changes.

This document is just a presentation and is not intended to be and does not constitute a "prospectus" or "disclosure document" or "offer document" or a "private placement offer letter" or an "offering memorandum" or an or a solicitation of any offer to purchase or sell any securities. It is clarified that this presentation is not intended to be a document offering for subscription or sale of any securities or inviting offers from any person, including the Indian public (including any section thereof) or from persons residing in any other jurisdiction, including the United States, for the subscription to or sale of any securities, including the Company's equity shares. No part of it should form the basis of or be relied upon in connection with any investment decision or any contract or commitment to purchase or subscribe for any securities.

This document has not been and will not be reviewed or approved by a regulatory authority in India or by any stock exchange in India.

Who are we?



Vision, mission and core values

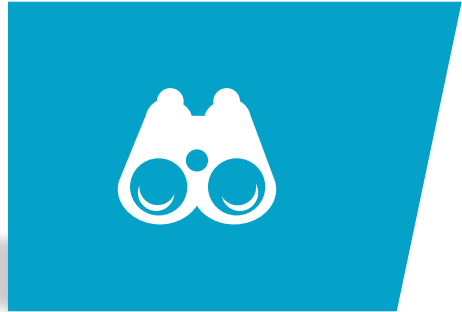

Vision

To be the most dependable and preferred supplier of forged and rolled components for the railways, automobile, mining, earthmoving, oil exploration, farm equipment, wind energy, bearing and general engineering industry by providing world class products at competitive prices through a knowledge-based happy organization



Mission

Create value for all business associates, shareholders and customers in all the areas of business in which we are associated with and to become an active partner in employee well-being and philanthropic causes



Core values



Customer centric approach



Continual improvements in systems



Commitment to human development



17
Countries served



41.5%
Export revenue mix
4.8% YoY increase

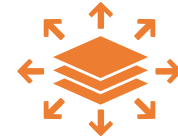

1,87,100T
Installed capacity



77.2%
Capacity utilisation



1,11,742T
Sales volume
42.2% YoY increase



₹2,320cr
Revenue
80.0% YoY increase



2.0%
Total turnover from EV



₹517cr
EBITDA
132.1% YoY increase



22.3%
EBITDA margin
5.0% YoY increase



14.3%
ROCE



18.4%
ROE



2.6x
Net debt to EBITDA







About us



Key highlights

- ✓ **Manufacturer and supplier** of a variety of auto and non-auto components
- ✓ **Global presence** with footprints in North America and Europe
- ✓ **2nd largest** forging player in India with over 30 years' of experience ⁽¹⁾
- ✓ Promoter possessing **multi-decade forgings industry experience**
- ✓ Continued focus on diversification with **foray into EV**
- ✓ Longstanding relationship with **marquee customers**

Industries served

Automotive	 OEMs	 Tier I auto companies			
Non-Automotive	 General enging. & steel	 Oil and gas exploration	 Railways	 Farm equipment	 Mining

Range of products forged

Installed capacity	Weight range of products forged (in kgs)
Press 1 – 12,500 T	80-200
Press 2 – 6,300 T	40-65
Press 3 – 4,500 T	20-40
Press 4 – 3,150 T	10-20
Press 5 – 2,000 T	05-10
Press 6 – 7,000 T	40-65
Hollow spindle line	15-25



6
 Manufacturing facilities in India

A (stable) / A1
 Long term rating by ICRA⁽²⁾

Revenue mix⁽³⁾

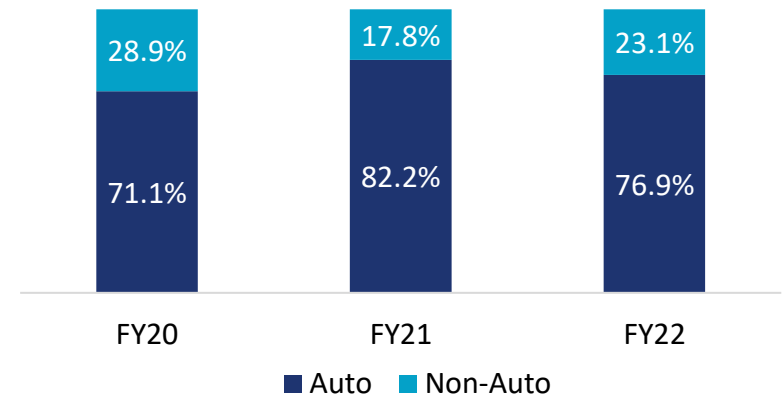

Note: T: Tonnes per annum
 1. In terms of revenue in FY22, as per industry reports
 2. <https://www.icra.in/Rationale/ShowRationaleReport/?id=106178>
 3. Based on consolidated numbers

Brief corporate journey

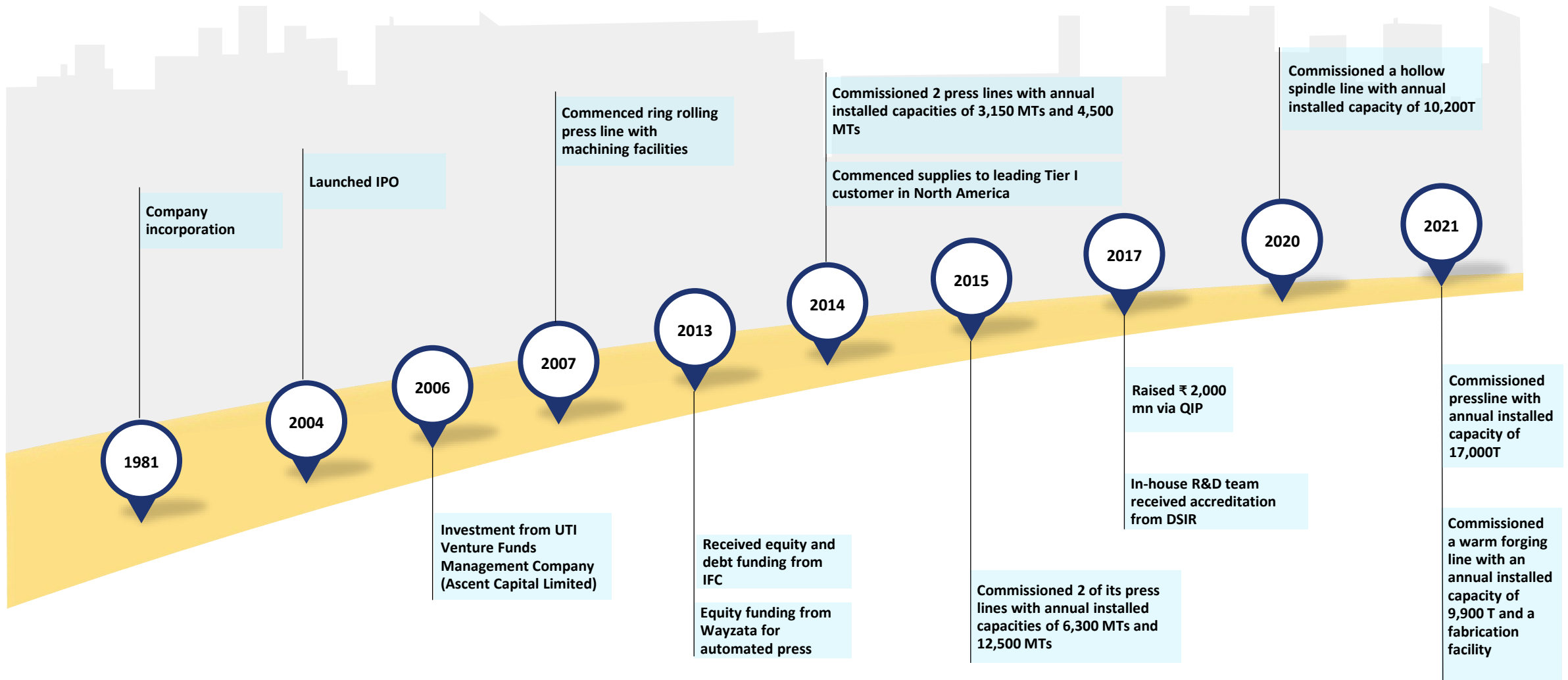

Note: Year represents calendar years

What differentiates us?



Diversified product profile offering (1/3)

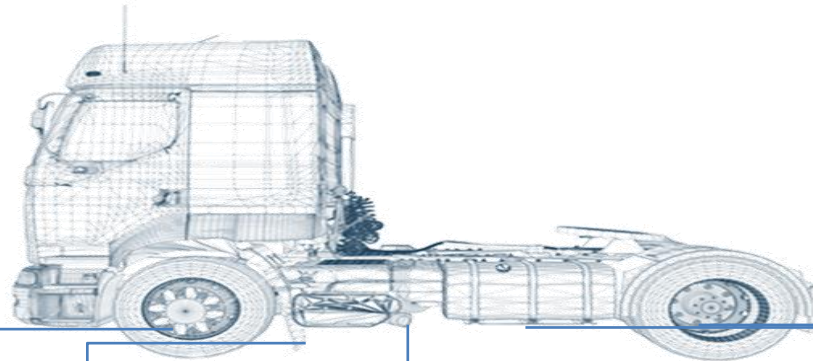

Front Axle & Steering



I Beam



Knuckle



Steering Arm



Tie Rod Arm



Sector Shaft



Front Hub

Engine



Crankshaft



Camshaft



Connecting Rod



Piston



Pitman Arm

Suspension & Chassis



BC Lever Assembly



Mounting Brackets



Yokes



UJ Cross

Transmission



Transmission Gears



Transmission Shafts

Rear Axle



Crown Wheel



Pinion



Differential Case



Differential Case Cover



Spindle



Rear Axle Shaft



Spider



Differential Gear & Differential Pinion

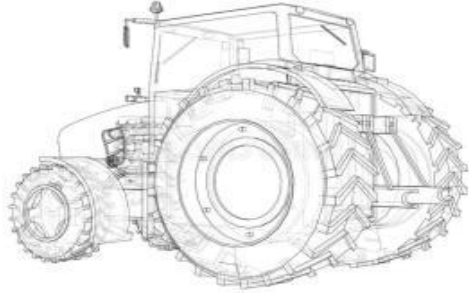

Tractors & Tillers



1,2,3 & 4 Cyl Forged Crankshafts



Crown Wheel & Pinion



Rear Axle Shafts



Transmission Shafts & Gears

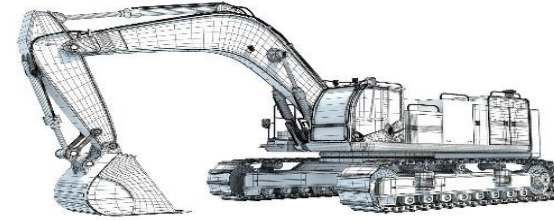

Earth Moving



Bucket



Backhoe Bucket



Shovel



Track Link



Track Roller



Bucket Tooth



Pivot Pin



Prop Shaft



Bearing Centre

Diversified product profile offering (3/3)

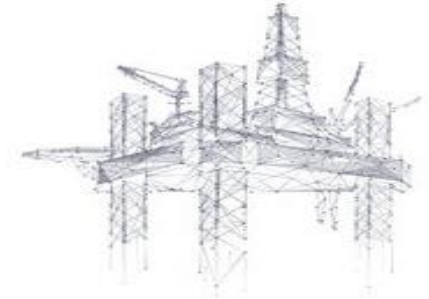
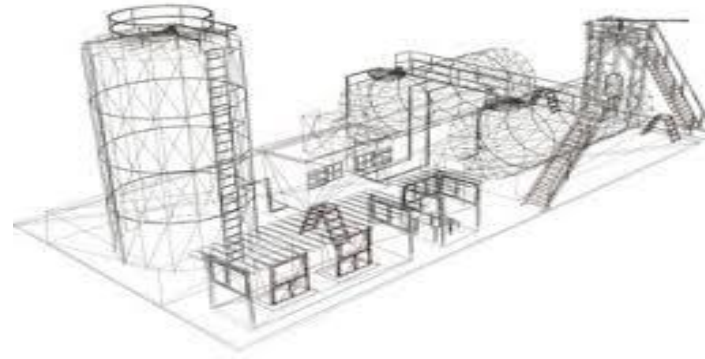
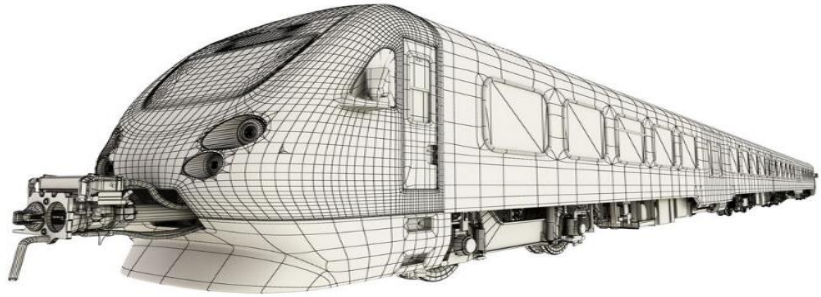

Railways



Bogie Frame



Bogie Bolster



Draw Gear Assembly



Screw Coupling



Hanger
Anti Roll Bar Assembly

Energy



Wing Nut



Valve Bonnet



T Bolt Socket Joint



Toothed Crusher Hammer



With consistently growing exports ⁽¹⁾

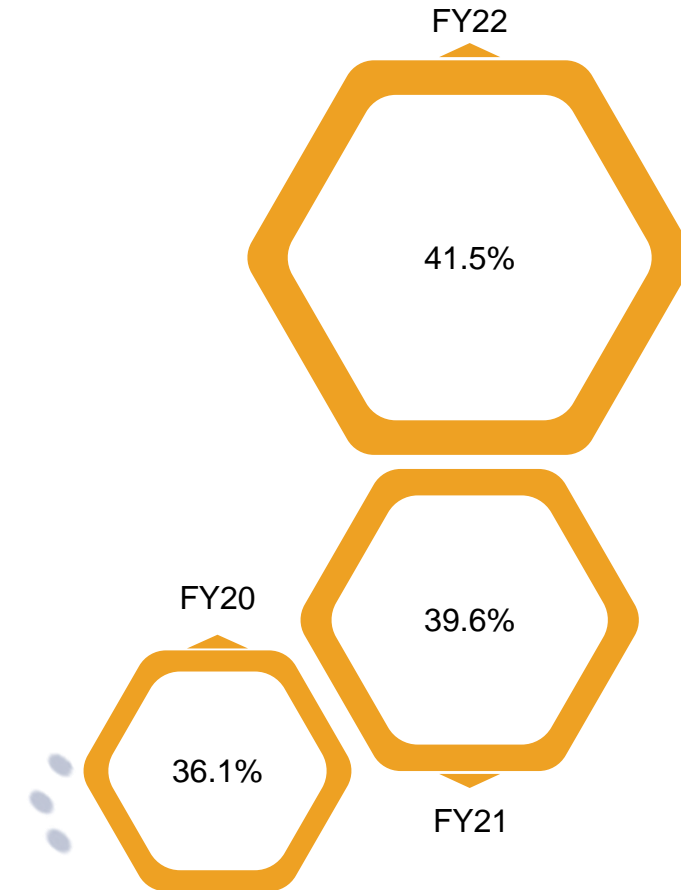

Note: Rounded off to nearest decimal place
1. Exports as a % of total revenue from operations on a consolidated basis

State-of-the-art manufacturing facilities...



Rolling

- ✓ **Rolling facility** with robotics which can roll crown wheels upto 500mm diameter and a capacity to forge components from 15-70 kgs
- ✓ Ability to forge one component in **25-40 seconds**



Forging



- ✓ **First company in India** to have fully automated 12,500 T wedge press line
- ✓ Capability to manufacture **complex and heavy-forged** components

Machined

- ✓ **State of the art machinery** and capabilities which includes turning
- ✓ Center, gear hobbing, shaping, shaving, broaching and rolling



- 6 large modern facilities in India >> **Strategic location benefits coupled with economies of scale**
- Technology led operations >> **Better solutions, optimum yield and enhanced quality of products**
- Extensive manufacturing capabilities >> **Ability to manufacture diverse products**
- Agile, flexible operations >> **Customized customer-centric solutions**

Accreditations and certifications



...that are strategically located providing us the competitive edge



Strategically located procurement and manufacturing base

Proximity to automobile manufacturing hubs and key suppliers

- ✓ RKFL's facilities in eastern India are located in close proximity to automobile manufacturing hubs and key suppliers of raw material
 - ✓ Less chance of supply interruption
 - ✓ Lower logistics cost
 - ✓ Reduced working capital requirements

Proximity to key export hubs

- ✓ Reduces logistics cost
 - ✓ 302km⁽¹⁾ to Kolkata port
 - ✓ 270km⁽¹⁾ to Haldia port

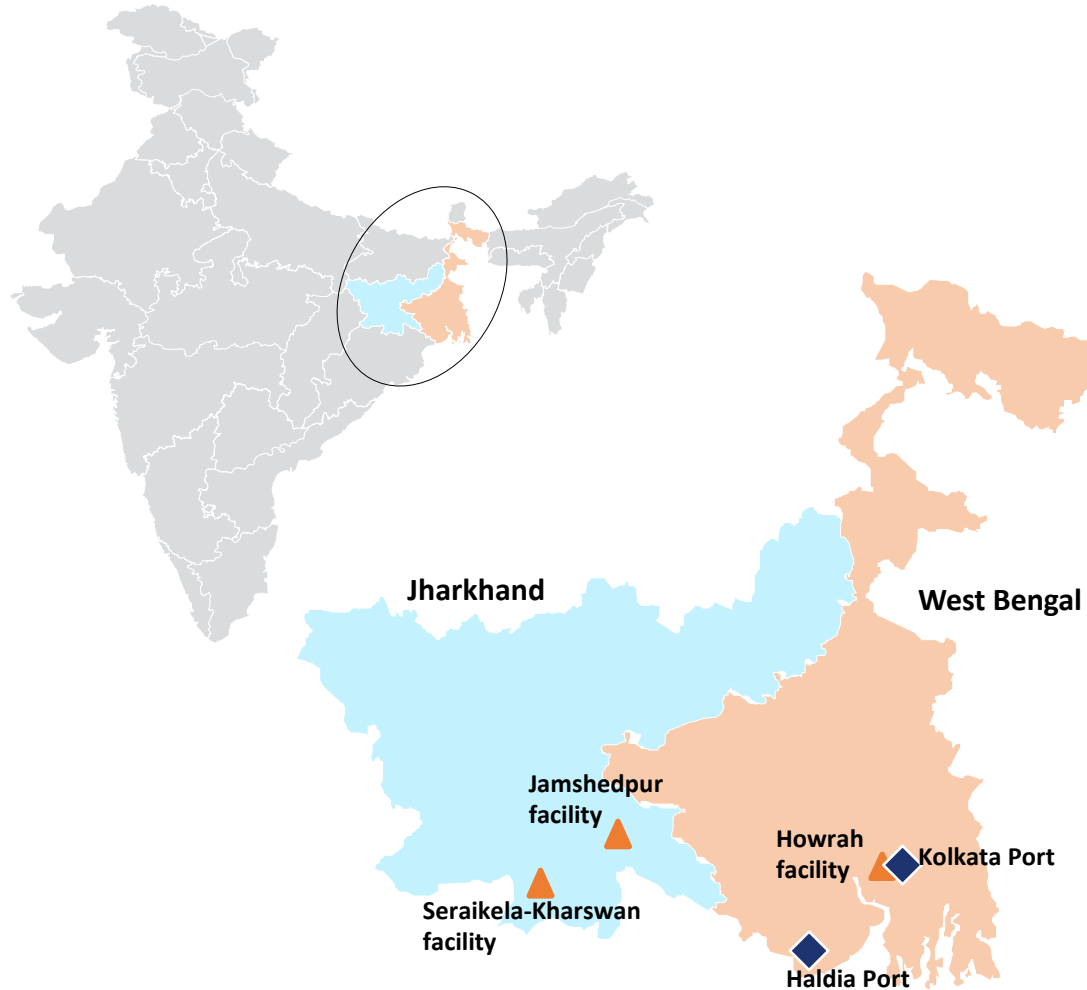

All facilities located within the same region

- ✓ Better integration resulting in efficient processes
- ✓ Improved coordination
- ✓ Overall cost savings, including administrative costs

Availability of labor

- ✓ Eastern region is the industrial center of India
- ✓ Low cost labor easily available
- ✓ Lower dependency on migrant laborers

Note:
1. Approximate distance from Jamshedpur facility

◆ Ports for export
▲ Manufacturing facilities

Technology leadership powered by in-house R&D and testing capabilities



In-house R&D and testing capabilities

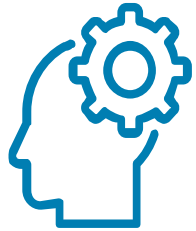

64 Member
R&D Team⁽¹⁾

Best-in-class testing facility

- National Accreditation Board for Testing and Calibration Laboratories accreditation for **technical competence**
- **TS16949 certifications** pertaining to quality management systems

Digital tools

Auto CAD

Commercial computer aided design and drafting software application

Unigraphics

Leading CAD/CAE/CAM software product

VeraCAD

Graphically interactive design software for stretch roll segments

FaroArm

Facilitates precise 3D measurements of both large and small parts while in production

Forge® Nxt

Simulates hot and cold-forming processes

DEFORM

Enables designers to analyze metal forming, heat treatment, machining and mechanical joining processes

Impact

Product innovation

Enhanced product quality

Cost benefits

Process improvements

Reduced manufacturing time

Improved customer satisfaction

Note:

1. As of March 31, 2022

Visionary management team...



Mahabir Prasad Jalan

Chairman and Wholetime Director



Naresh Jalan

Managing Director



Chaitanya Jalan

Wholetime Director



Lalit Kumar Khetan

Wholetime Director, Chief
Financial Officer



Rajesh Mundhra

Company Secretary &
Sr. GM Finance



Milesh Gandhi

Vice President – Marketing
& Sales

...backed by a strong governance structure



Committed board of directors



Mahabir Prasad Jalan
Chairman and
Wholetime Director



Naresh Jalan
Managing Director



Chaitanya Jalan
Wholetime Director



Lalit Kumar Khetan
Wholetime Director



Pawan Kumar Kedia
Wholetime Director



Amitabh Guha
Non-Executive
Independent Director



Padam Kumar Khaitan
Non-Executive,
Independent Director



**Partha Sarathi
Bhattacharya**
Non-Executive,
Independent Director



Ram Tawakya Singh
Non-Executive,
Independent Director



Ranaveer Sinha
Non-Executive,
Independent Director



Rekha Shreeratan Bagry
Non-Executive,
Additional Independent Director



Sandipan Chakrovorty
Non-Executive,
Independent Director



Sanjay Kothari
Non-Executive,
Additional Independent Director



Yudhisthir Lal Madan
Non-Executive,
Independent Director

Strong governance standards



**9 independent
directors** as against
statutory requirement of 7
directors



Audit committee comprising of
all **independent
directors**



Nomination and remuneration
committee comprising of all
independent directors



Presence of a
Big 4 auditor

Strong operating and financial performance (1/2)



Substantial capacity augmentation with highest revenue clocking in last 3 financial years, much ahead of pre-Covid levels...

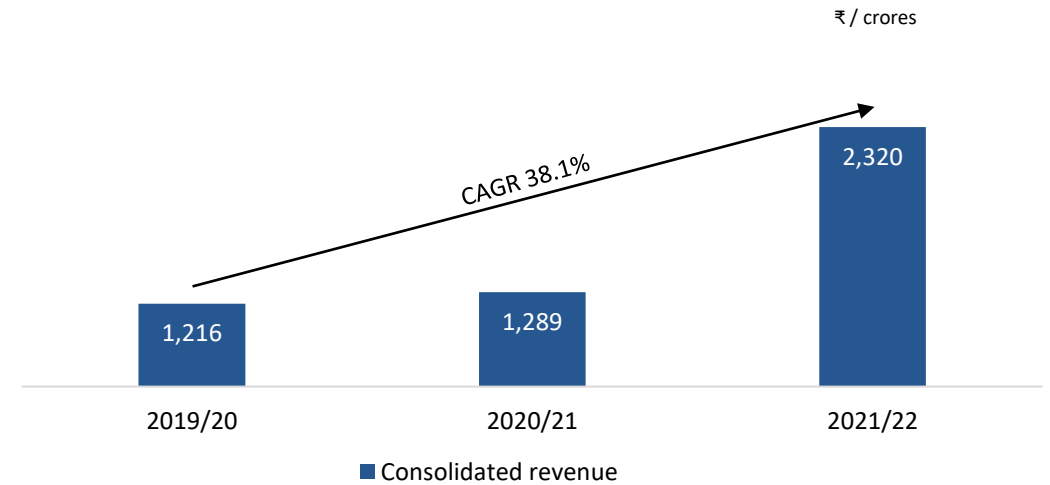
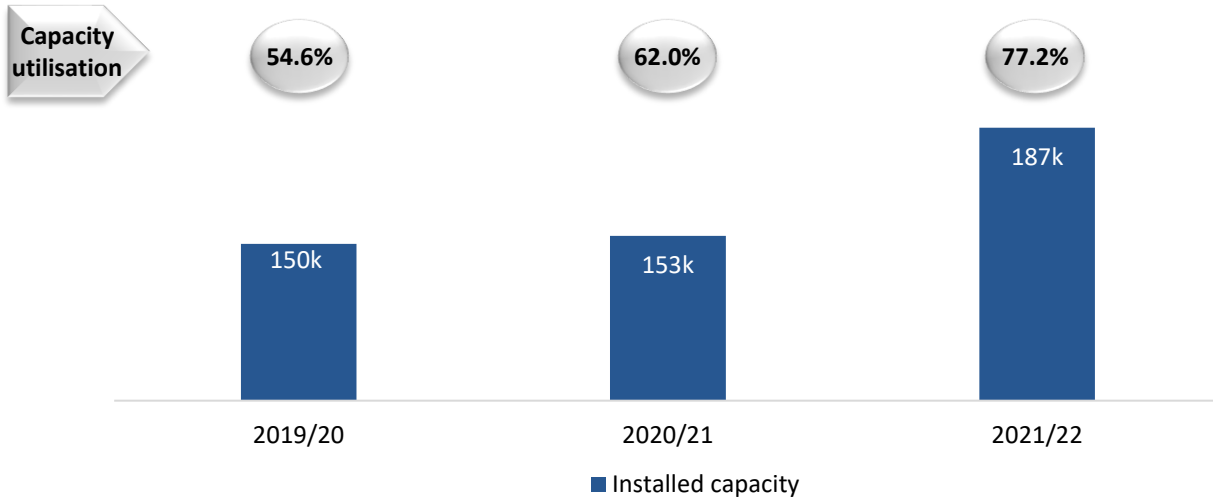

...leading to growth in profitability

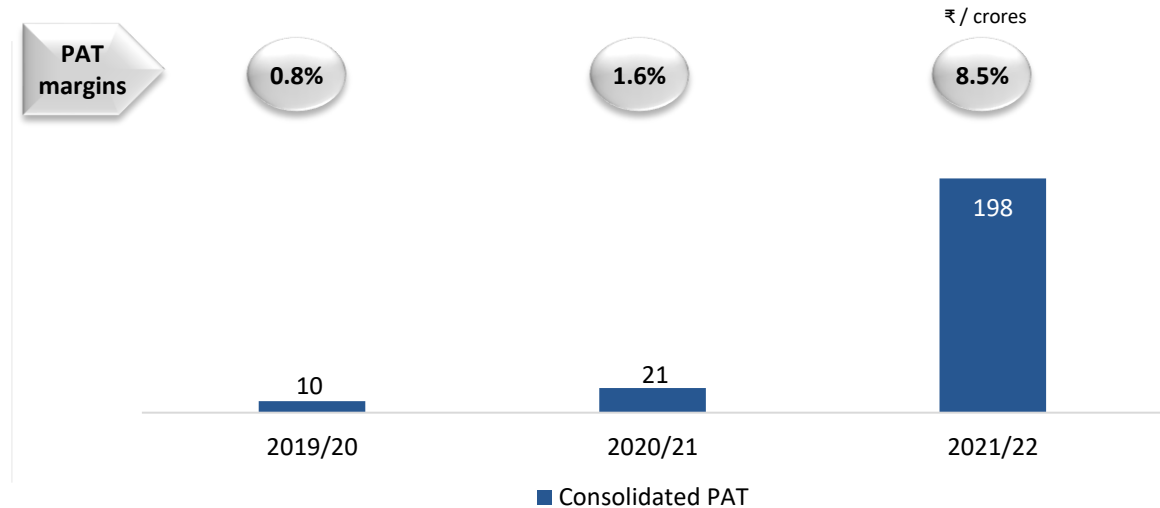
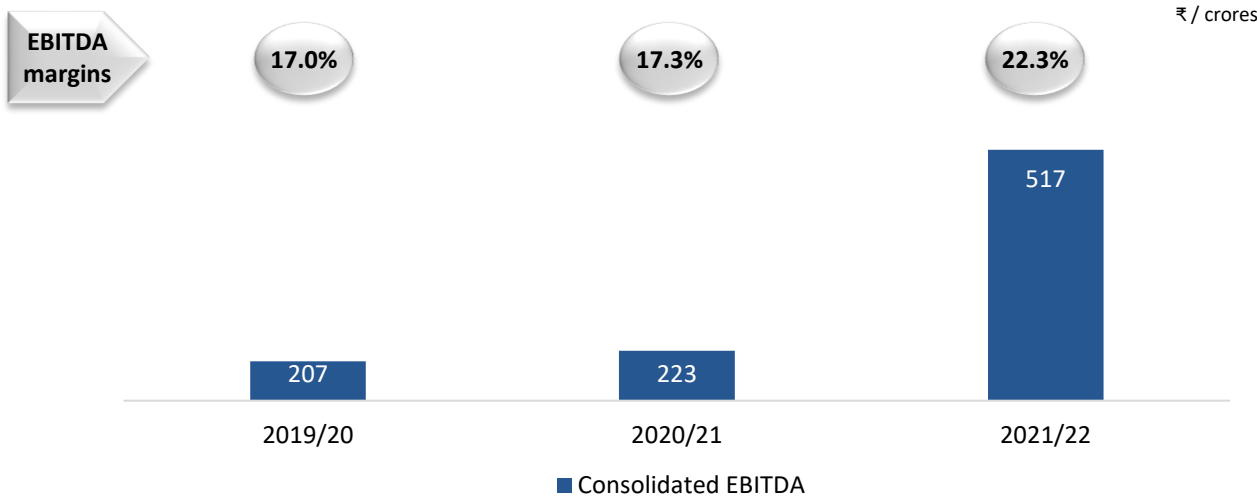

Note: Rounded off to the nearest whole number, k represents '000, While the financials are in lakh, for the ease of presentation numbers are represented in crores

Strong operating and financial performance (2/2)



Improving operating and financial leverage...

Opex as % of revenue

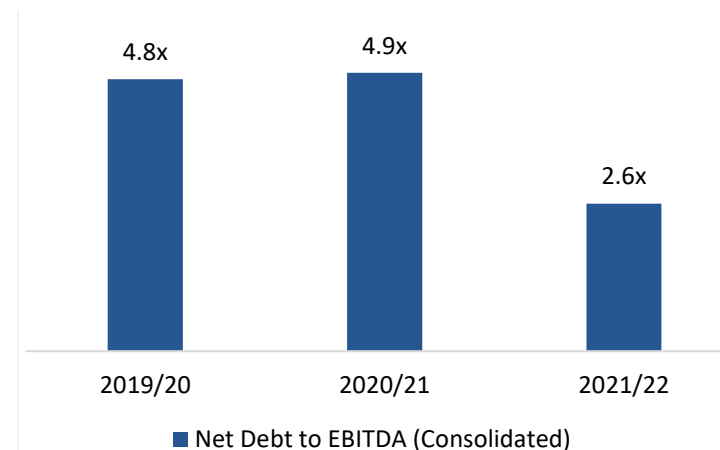
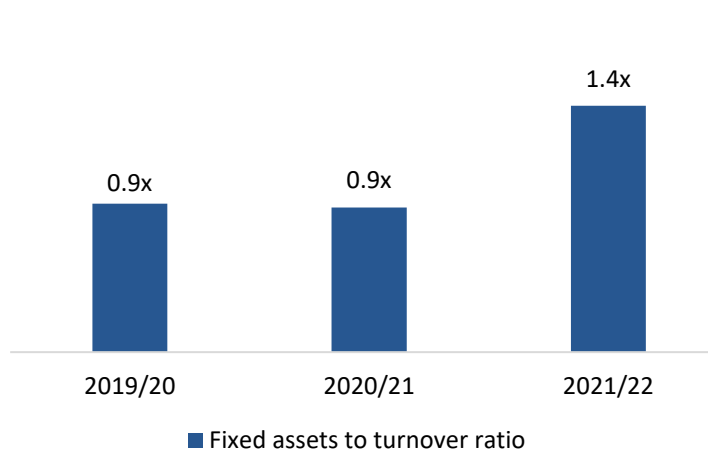
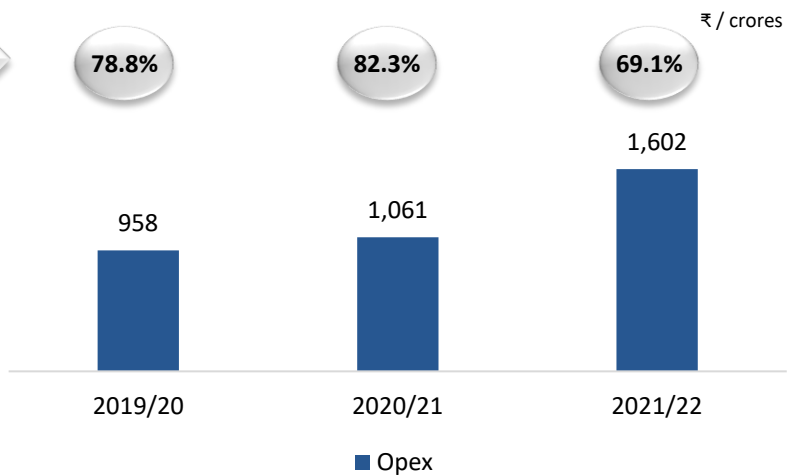

... leading to a higher ROCE and ROE

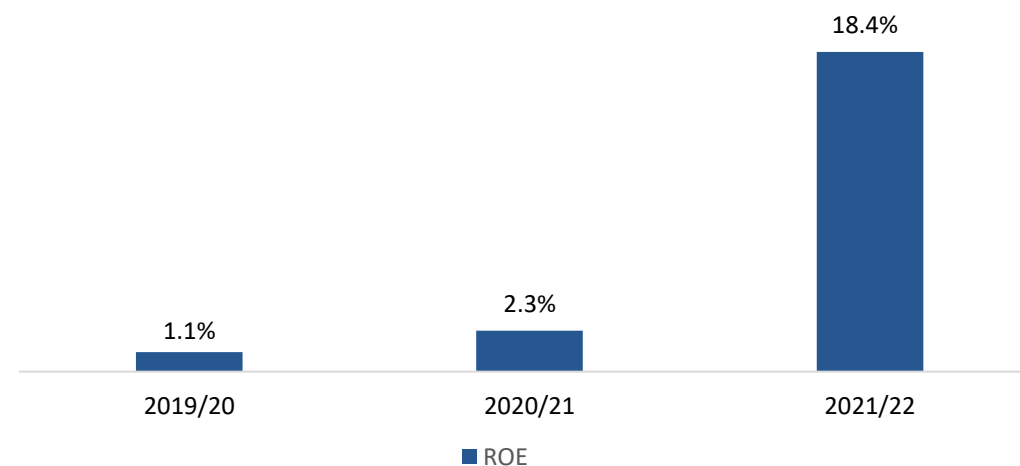
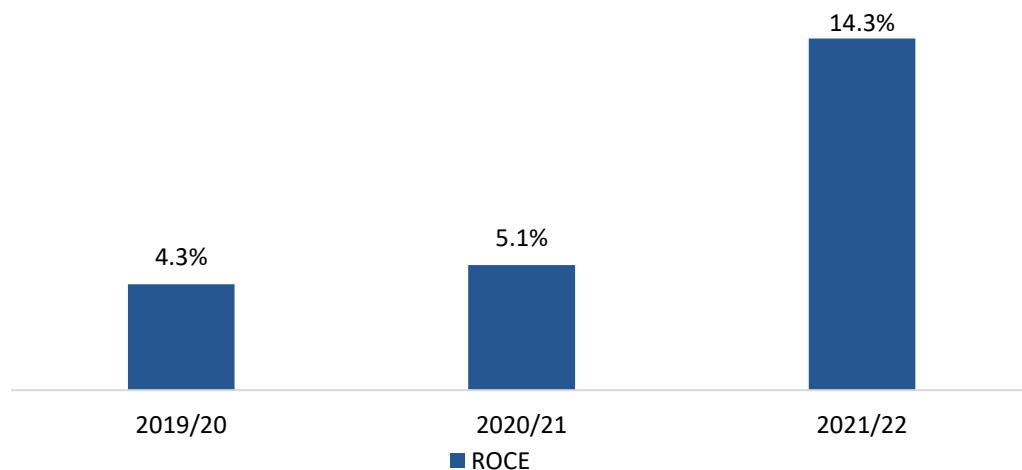

Note: Rounded off to the nearest whole number, While the financials are in lakh, for the ease of presentation numbers are represented in crores
 Opex = Total Expenses excluding Depreciation & Interest / Revenue
 Fixed assets to turnover ratio = Revenue / Fixed Assets
 ROCE = EBIT less other income / (Net debt + equity)

ROE = Net profit / Net worth
 Net debt = Long term borrowings + short term borrowings – cash & cash equivalents – bills discounted

Delivering highest EBITDA in the last 8 quarters



Q42021/22 shows the results of a strong execution oriented approach leading to a good post Covid recovery and a strong turnaround

Consolidated revenue and EBITDA for last 8 quarters

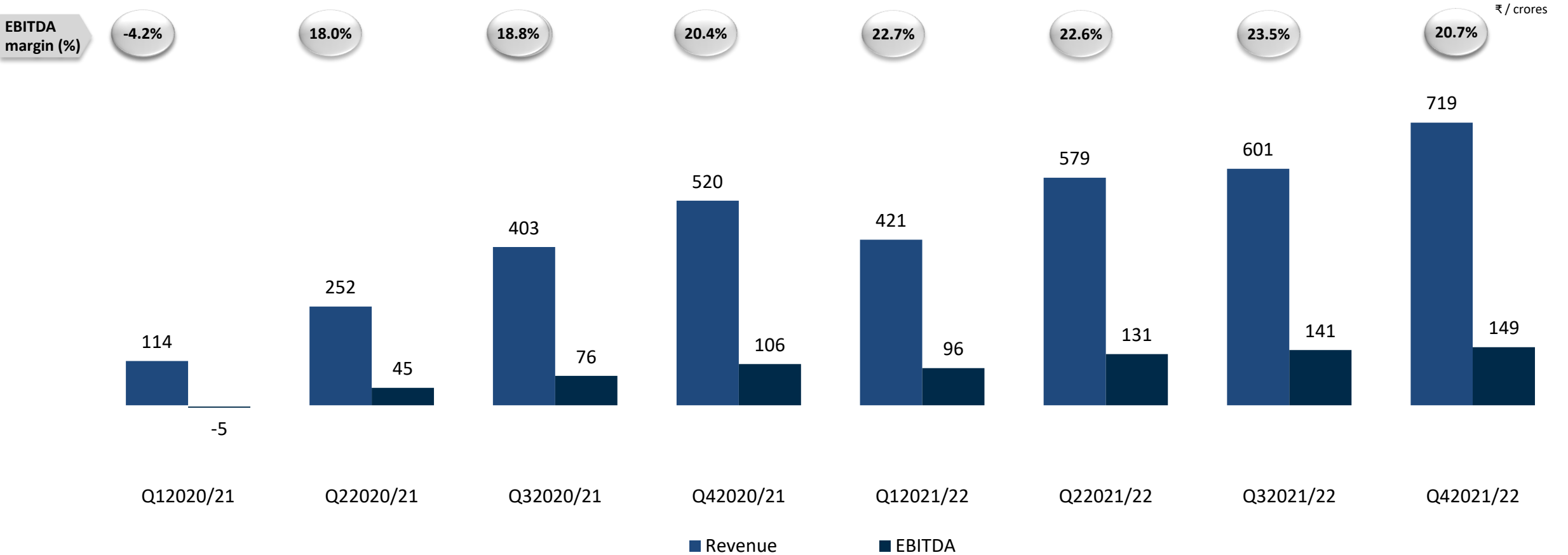

Note: Rounded off to the nearest whole number, While the financials are in lakh, for the ease of presentation numbers are represented in crores

Key ESG targets for RKFL



RKFL for environment consciousness

The vision is to commit to preserving and protecting the environment across its operations



50%

Renewable energy mix by 2028

2050

Achieve Carbon neutrality across Scope 1 & 2

80%

Of suppliers in same states as RKFL plants by 2024

100%

Recycling of water by 2025

30%

Reduction in specific water use by 2025

50%

Decrease in overall waste through 3 R's

RKFL for communities

The vision is to be the employer and partner of choice for our employees and suppliers and help local communities thrive



100%

Key Suppliers will be audited in 2024

ZERO

Accidents by enhancing safety practices by 2024

Upskilling

Program to be launched in 2023

2 Days

Paid volunteering leave for all employees starting 2023

100

Employ and train people from local villages by 2030

100%

Employees sensitized on ESG and Human Rights by 2025

RKFL for the long run

The vision is to operate ethically and responsibly with transparency



10%

Increase in Women representation on Board by 2030

Zero

Gender pay disparity by 2030

TCFD

Alignment 2030

Strategy for future growth

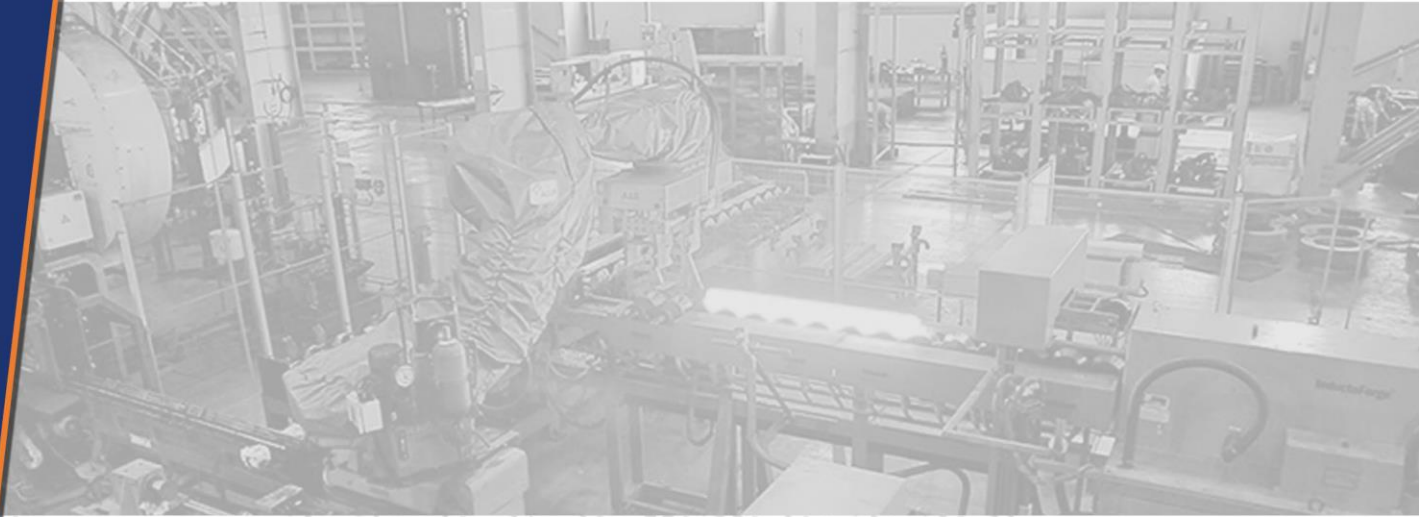

Multiple vectors to accentuate growth and increase profit

Clearly identified growth strategies

Continued growth in forging content in vehicles with existing customer base⁽¹⁾

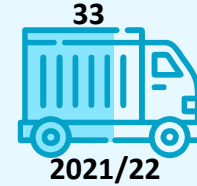

Continued focus on diversification

- Geographical – Further diversification into international markets
- Sector – Increasing the gamut of products that are currently manufactured towards non-automotive customers
- Product – Diversification into high margin, niche products and EV

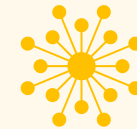

Continued investment in innovation and technology

- Enhancing R&D capabilities to further provide competitive edge with respect to quality and cost
- Investment in modern technology and equipments solidifying the competitive edge



Continued cost and process optimization driving operating leverage

- Accelerated efforts to optimize and improve process efficiency
- Focus on achieving economies of scale



Note:
1. Number to the right indicate number of different types of forging parts manufactured by RKFL

Growing presence in EV globally

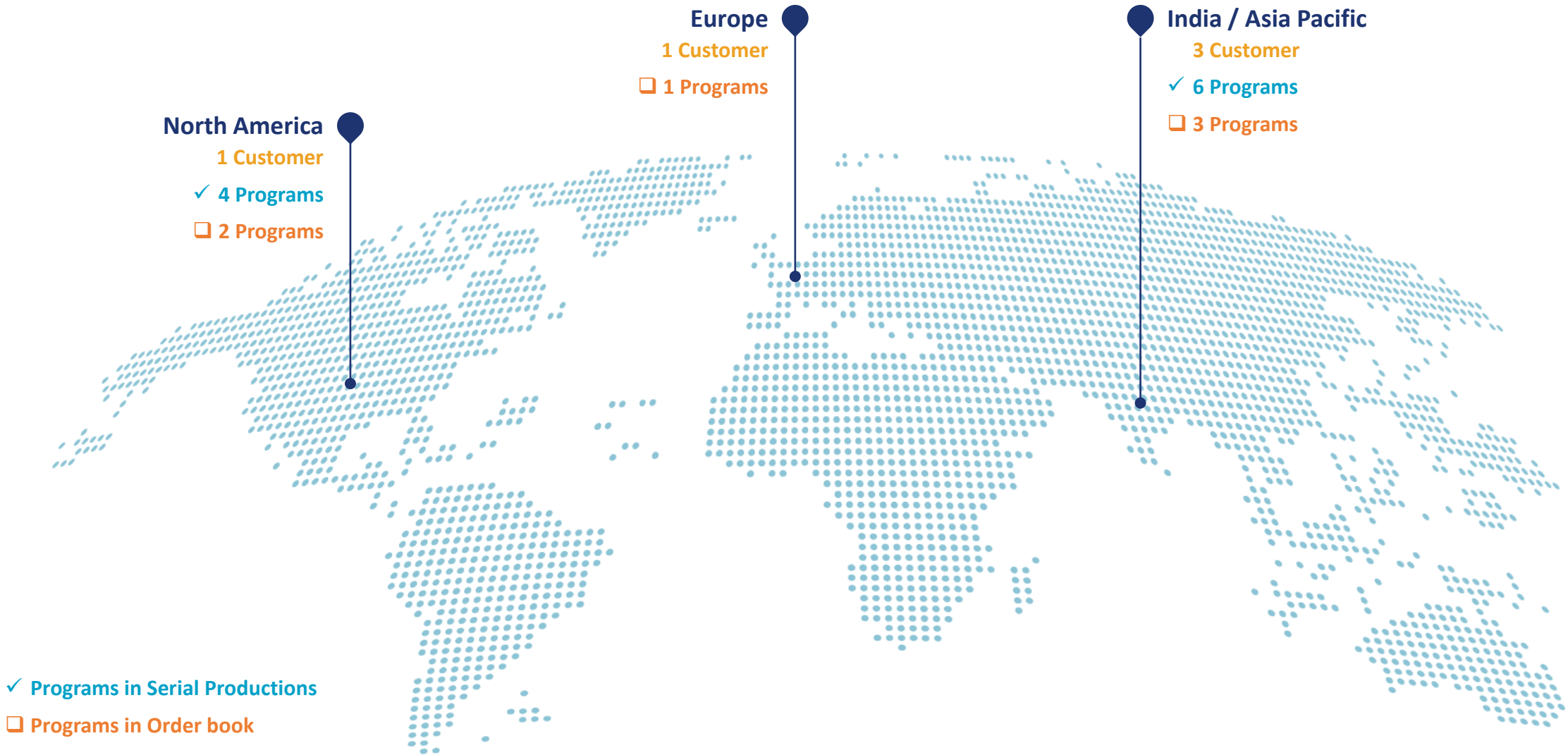

In 2021/22, 2.0% of total turnover on a consolidated basis came from EV segment

Appendix



Organisation structure and shareholding



Latest organisation structure⁽¹⁾

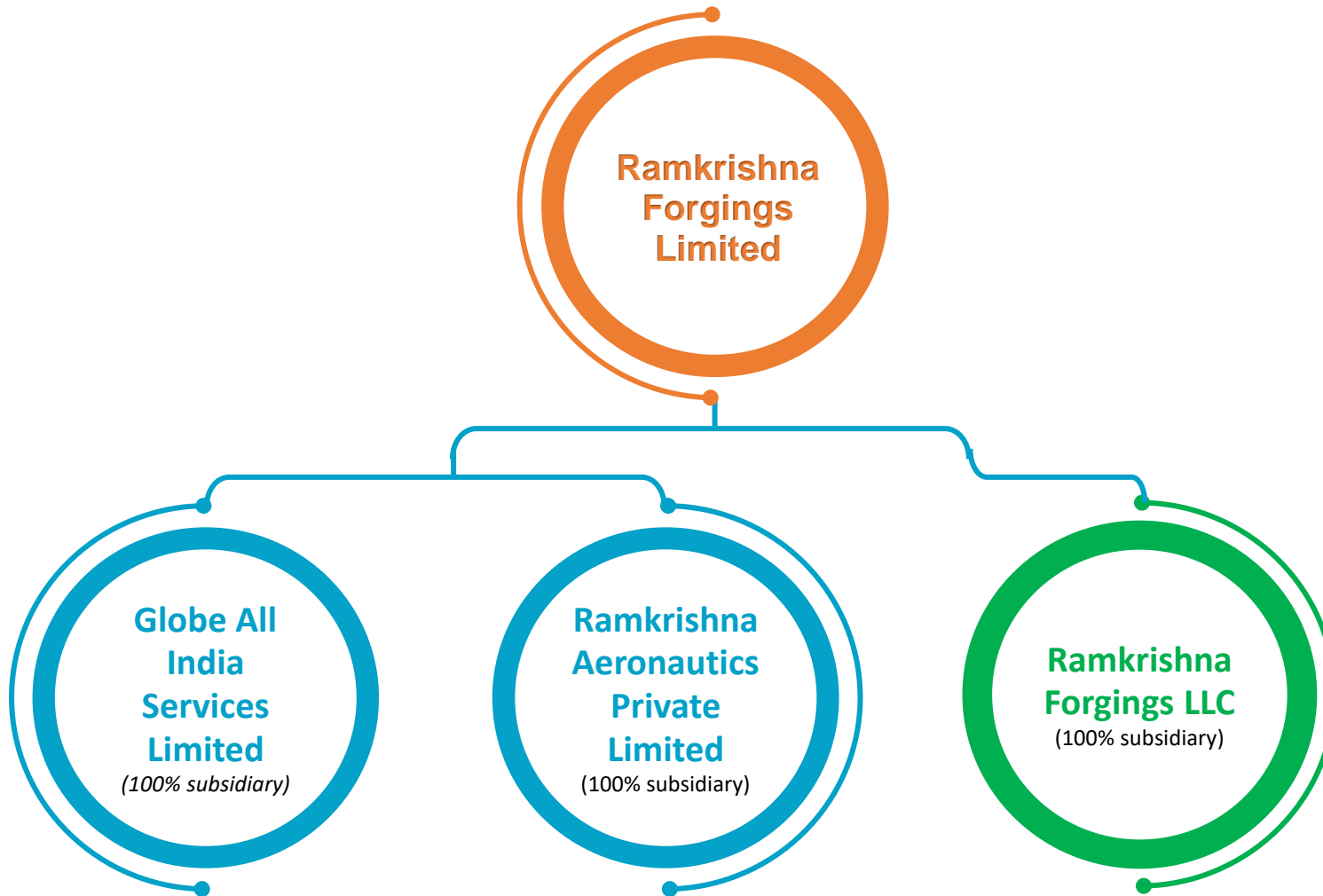

Latest shareholding⁽²⁾

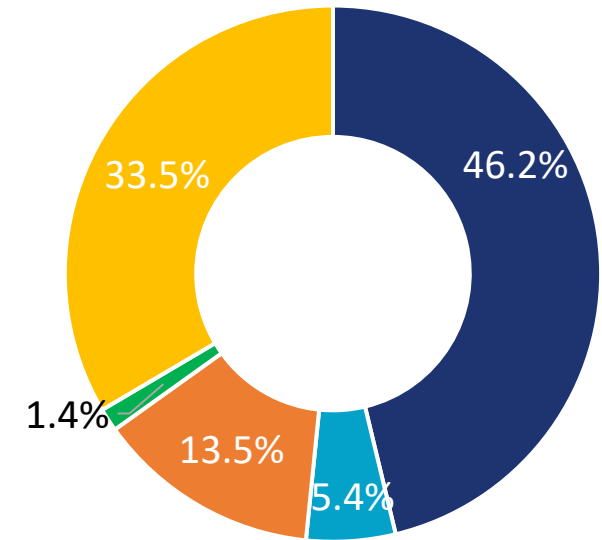

- Promoter & Promoter Group
- DII
- FII
- AIF
- Others

₹ 2,587 Cr
Market Cap
as on June 2, 2022⁽³⁾

Note:
 1. The subsidiaries contributed to 1.65% of the total gross revenues from operations of the overall holding company as per FY21 annual report
 2. As of March 31, 2022
 3. As per BSE website

Financial snapshot

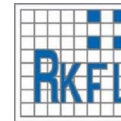

RKFL Consolidated Q42020/21 vs Q42021/22

₹ /crores



RKFL Consolidated 2020/21 vs 2021/22

₹ /crores



■ PY ■ CY

Note: Rounded off to the nearest whole number, While the financials are in lakh, for the ease of presentation numbers are represented in crores

Consolidated financials – Balance sheet



<i>Assets (₹ /crores)</i>	2019/20	2020/21	2021/22
Non - Current Assets	1,437	1,551	1,677
Property Plant & Equipments	1,160	1,224	1,436
CWIP	219	276	129
Goodwill	5	5	5
Intangible assets	1	1	1
Right of use asset	9	10	31
Financial Assets			
(i) Trade receivables	4	0	0
(ii) Investments	0	0	0
(iii) Loans	14	2	2
(iv) Other Financial Assets	1	13	14
Non - Current Assets (Net)	2	2	2
Deferred tax Assets (net)	0	3	3
Other Non Current Assets	22	15	53
Current Assets	792	1,153	1,806
Inventories	359	438	709
Financial Assets	0	0	0
(i) Investments	0	0	55
(ii) Trade receivables	343	573	891
(iii) Cash and cash equivalents	3	67	36
(iv) Bank balances other than (ii) above	1	1	2
(v) Loans	14	0	1
(vi) Other financial assets	27	7	30
Current Tax Assets (Net)	5	0	2
Other Current Assets	41	67	80
Total Assets	2,229	2,704	3,484

<i>Equity and Liabilities (₹ /crores)</i>	2019/20	2020/21	2021/22
Total Equity	876	883	1,078
Share Capital	33	32	32
Reserves & Surplus	843	851	1,046
Non-Current Liabilities	559	757	982
Financial Liabilities			
(i) Borrowings	479	670	869
(ii) Lease Liabilities	4	4	23
Provisions	0	1	1
Deferred Tax Liabilities	59	65	74
Other Non Current Liabilities	17	17	16
Current Liabilities	794	1,065	1,423
Financial Liabilities			
(i) Borrowings	402	559	722
(ii) Lease Liabilities	1	0	4
(iii) Trade Payables	214	433	608
(iv) Other Financial Liabilities	159	50	52
Other Current Liabilities	12	16	28
Provisions	6	5	6
Current tax liabilities (net)	0	2	2
Total Equity & Liabilities	2,229	2,704	3,484

Note: Rounded off to the nearest whole number, While the financials are in lakh, for the ease of presentation numbers are represented in crores

Consolidated financials – Income statement



₹ /crores	2019/20	2020/21	2021/22
Revenue from operations	1,216	1,289	2,320
Cost of goods sold ⁽¹⁾	594	640	1,161
Gross profit	622	648	1,160
Gross profit margin	51.2%	50.3%	50.0%
Employee cost	103	96	127
Power and fuel	97	94	152
Other expenses	215	236	363
EBITDA	207	223	517
EBITDA margin	17.0%	17.3%	22.3%
Other income	7	6	1
Depreciation and amortisation expense	121	117	169
EBIT	94	112	349
EBIT margin	7.7%	8.7%	15.1%
Finance cost	79	80	96
Profit before tax	15	32	253
Profit before tax margin	1.2%	2.5%	10.9%
Tax	5	11	55
Profit after tax	10	21	198
Profit after tax margin	0.8%	1.6%	8.5%

Note: Rounded off to the nearest whole number, While the financials are in lakh, for the ease of presentation numbers are represented in crores
 1. Cost of Goods Sold Includes; Cost of materials consumed, Cost of Services, Trading Purchases (Increase) / Decrease in inventories of finished goods, work in progress scrap and traded group

Consolidated financials – Cash flow statement



₹ /crores	2019/20	2020/21	2021/22
Cash flow from operating activities			
PBT	15	32	253
Depreciation	121	117	169
Adjustments (including finance costs)	61	73	78
(Increase)/ Decrease in working capital	65	(80)	(410)
Less: Taxes paid	(7)	(1)	(48)
Net cash flow from operating activities	254	140	43
Cash flow from investing activities			
Net proceeds from purchase/ sale of property (including intangible assets)	(228)	(231)	(300)
Others	(4)	9	(55)
Net cash flows used in investing activities	(231)	(222)	(354)
Cash flow from financing activities			
Issue / (Buyback) of shares and related items	0	(16)	2
Interest and borrowing costs paid	(3)	(78)	(98)
Net proceeds from/ (repayment of) long term borrowings	24	177	243
Net proceeds from/ (repayment of) short term borrowings	40	63	124
Dividends	(5)	–	(5)
Others	(78)	(0)	14
Net cash flows used in financing activities	(22)	147	280
Net increase / (decrease) in cash and cash equivalents	1	65	(31)
Cash and cash equivalents at the beginning of the year	2	3	67
Cash and cash equivalents at year end	3	67	36

Note: Rounded off to the nearest whole number, While the financials are in lakh, for the ease of presentation numbers are represented in crores



Thank you