



Field Installation and Usage Instructions

Part No. TMA32-15

Air Delivery / Drape Support

For all model TMM chairs except TMM3



5516 S.W. 1st Lane – Ocala, FL 34474-9307
Phone: 1-800-237-3377 - Fax: 1-352-854-9544
www.transmotionmedical.com

Document No.: IM TMA32-15
Revision: C

TABLE OF CONTENTS

IMPORTANT NOTES ABOUT THIS MANUAL3

SPECIAL NOTES - SIGNAL WORDS3

TOOLS REQUIRED.....4

PARTS INCLUDED FOR TMA32-154

PREPARING CHAIR FOR AIR DELIVERY / DRAPE SUPPORT.....5

AIR DELIVERY / DRAPE SUPPORT INSTALLATION6

CAUTIONARY USAGE INSTRUCTIONS.....8

PREVENTIVE MAINTENANCE8

CLEANING INSTRUCTIONS9

IMPORTANT NOTES ABOUT THIS MANUAL

This Field Installation and Usage Instruction manual is intended to assist you with installation of your TransMotion Medical Product. Carefully read this manual before using the equipment or doing service / maintenance on it. If you are unable to understand the WARNINGS, CAUTIONS, and instructions, contact TransMotion Medical Customer Service before attempting to operate or service the equipment. Otherwise, personal injury or property damage may result.

To ensure safe operation of this device, it is essential that methods and procedures be established for educating and training staff on the safe and effective operation of the product.

TransMotion Medical reserves the right to change specifications without notice.

The information contained in this document is subject to change without notice.

Specifications listed are nominal, and operation may vary slightly from unit to unit due to tolerance variations.

Figures contained within this document may not depict exactly the model you have. This document may cover many closely related models.

SPECIAL NOTES - SIGNAL WORDS

Signal words are used in this manual and apply to hazards which could result in injury or property damage. The following is a definition of those signal words as used in this document:

DANGER

Indicates an imminently hazardous situation which, if not avoided, will result in death or serious injury.

WARNING

Indicates a potentially hazardous situation which, if not avoided, could result in death or serious injury.

CAUTION

Indicates a potentially hazardous situation which, if not avoided, may result in minor or moderate injury. It may also be used to alert against unsafe practices or potential property damage hazards.

NOTICE

Provides important information, makes special instructions clearer, or provides service personnel information to make maintenance easier.

TOOLS REQUIRED

Tools are not required to install Air Delivery / Drape Support

PARTS INCLUDED FOR TMA32-15

Air Delivery / Drape Support is shipped as shown and does not require added assembly.

If any features seem damaged due to shipping, contact TMM Service Department toll-free at 1-800-237-3377.

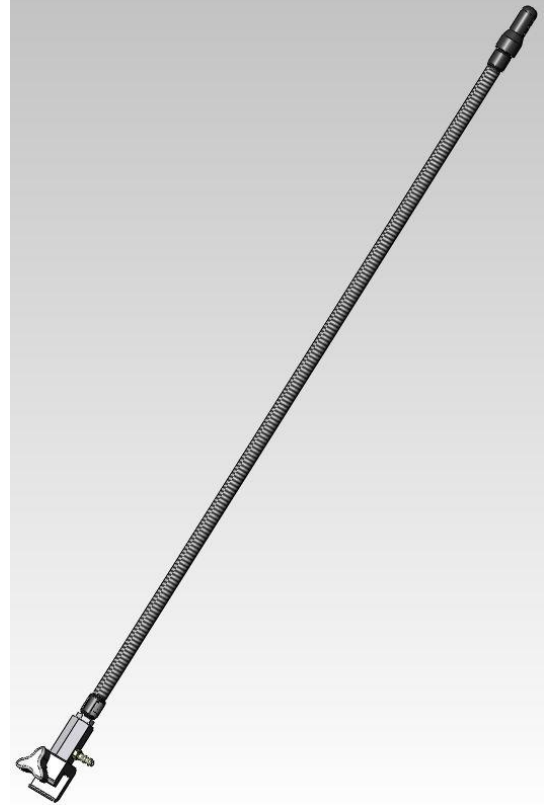

PREPARING CHAIR FOR AIR DELIVERY / DRAPE SUPPORT

- 1) Fold down arm rail on desired side of installation.



AIR DELIVERY / DRAPE SUPPORT INSTALLATION

- 1) Loosen mounting knob to allow clearance for surgical bar attachment

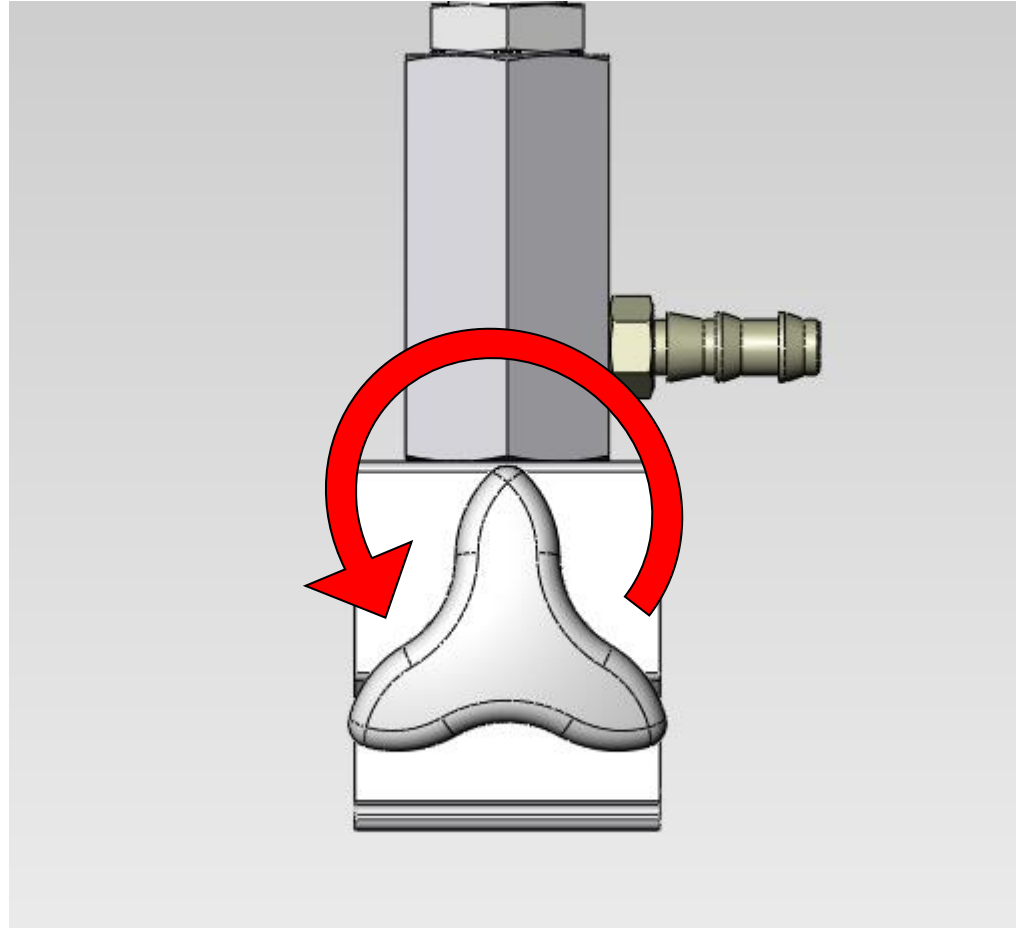

- 2) Hook mounting bracket onto surgical bars and place in desired location.

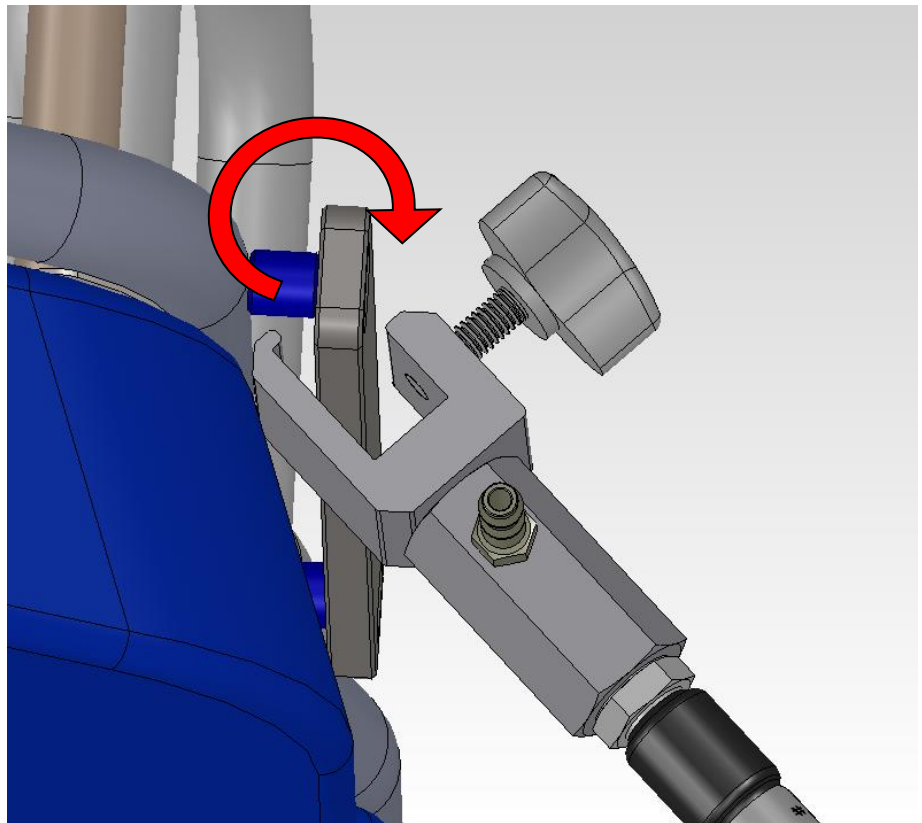

- 3) Tighten mounting knob until Air Delivery / Drape Support is locked securely in place

CAUTION

Ensure support is locked firmly in place to avoid accessory malfunction.

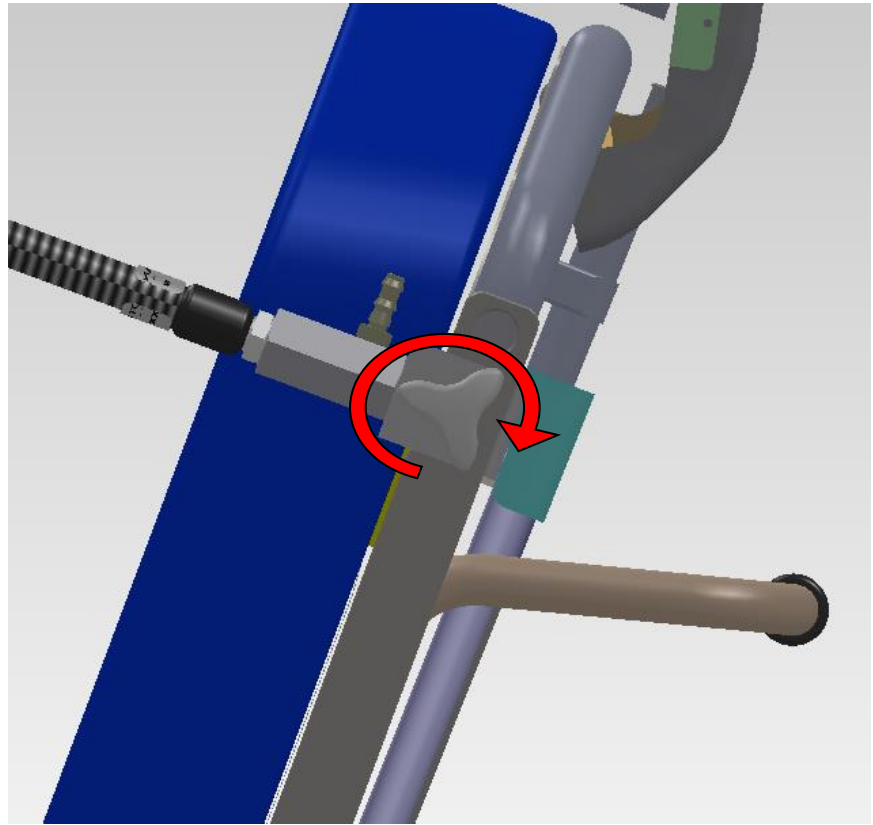

CAUTIONARY USAGE INSTRUCTIONS

When using this accessory, please follow these cautionary usage instructions:

CAUTION AIR DELIVERY / DRAPE SUPPORT IS NOT STERILIZED PRIOR TO SHIPMENT. PERFORMING THE CLEANING PROTOCOL DETAILED BELOW IS RECOMMENDED PRIOR TO THE FIRST USE.

CAUTION TO PREVENT PERSONAL INJURY TO MEDICAL PERSONNEL AND / OR PATIENT, ENSURE AIR DELIVERY / DRAPE SUPPORT IS PROPERLY INSTALLED PRIOR TO USE OF AIR SYSTEM.

PREVENTIVE MAINTENANCE

To ensure proper operation, this accessory should be inspected and maintained as described below.

| COMPONENT | FREQUENCY | PROCEDURE | TOOL | COMMENT |
|---------------|--------------------|---|------|--|
| Mounting Knob | Every three months | Inspect locking mechanism for proper tightening capability. | - | Contact TMM Customer Service for replacement parts as needed |
| Air Hose | Every three months | Inspect hose for damage and/or air leaks | - | Contact TMM Customer Service for replacement parts as needed |

CLEANING INSTRUCTIONS

⚠ CAUTION STEAM AND/OR PRESSURE CLEANING CHAIR WILL VOID WARRANTY

| COMPONENT | FREQUENCY | PROCEDURE | CLEANING AGENT * | COMMENT |
|---------------------------------|--|--|---|---|
| All Rails and Painted Metal | As required/in accordance with facility policies | Wipe with damp cloth and allow to air dry | Facility approved detergents, disinfectants & water | Check for chipped paint/chrome |
| Base Cover | As required/in accordance with facility policies | Wipe with damp cloth and allow to air dry | Facility approved detergents, disinfectants & water | Check for peeling or missing labels |
| Actuators and Battery Pack | As required/in accordance with facility policies | Wipe with damp cloth and allow to air dry | Facility approved detergents, disinfectants & water | Clean exterior surfaces only with minimal water |
| Pendants | As required/in accordance with facility policies | Wipe with damp cloth and allow to air dry | Facility approved detergents, disinfectants & water | Clean exterior surfaces only with minimal water |
| All Other Surfaces | As required/in accordance with facility policies | Wipe with damp cloth and allow to air dry | Facility approved detergents, disinfectants & water | Check for damage |
| TransMotion Medical Accessories | As required/in accordance with facility policies | Wipe with damp cloth and allow to air dry | Facility approved detergents, disinfectants & water | Check for damage |
| 3rd Party Accessories | As required/in accordance with facility policies | Consult manual provided by accessory manufacturer. | | |

* Use of Facility approved detergents and disinfectants must comply with the instructions provided by the manufacturer(s) of those products.

Upholstery Care & Cleaning Instructions

Proper care is essential in ensuring the durability and reliability of TransMotion Medical upholstery. In general, all products should be:

1. Cleaned
2. Disinfected (in accordance with facility policy)
3. Rinsed
4. Allowed to air dry

It is important to note that the terms “disinfecting” and “cleaning” should not be used interchangeably. Disinfectants alone will not provide adequate cleaning since they do not have the appropriate properties to cut grease or oil and remove grime, hair or skin oils. The appearance, feel and performance of your upholstery may diminish if not cleaned properly.

Cleaning:

Remove hair, grime and body oils. Your upholstery should be cleaned on a regular basis with a damp cloth soaked in a mild soap and water solution. Avoid harsh detergents or chemicals that could damage the finish of your product. If disinfecting with manufacturer approved chemicals or bleach, the upholstery MUST be wiped off using clean water on a damp cloth and allowed to air-dry as a final step. Failure to rinse upholstery with clean water can result in a build-up of residues that, over time, may lead to drying, cracking or other undesirable changes to appearance, feel and performance.

Retain all instructional tags for future use.

Contact the manufacturer of the fabric used in your upholstery for a current list of approved disinfectants. TransMotion Medical Customer Care can assist with identifying which upholstery was used with your Stretcher-Chair.

For customer supplied and non-standard materials, please refer to the individual manufacturer’s cleaning instructions.