

Lambda-X Space Activities

Jean-Hervé Lecat

Business Development Manager Space & Defence

jhlecat@lambda-x.com

09/10/2025

LAMBDA-X | **VERHAERT**
HIGH-TECH

Your Challenges, Lambda-X approach & proposed solutions



- Vacuum
- Thermal Operational Range
- Radiation
- Vibration and Shock

Lambda-X leverages its expertise in athermal design, radiation hardening, and the optimization of reliable mechanical designs to achieve **space-qualified** optics.

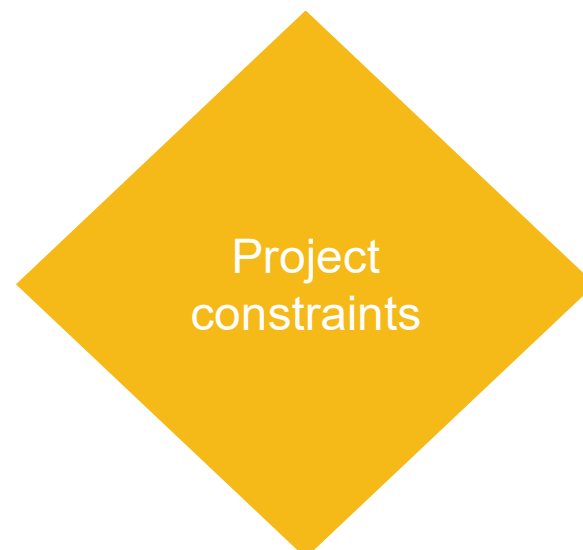

- Limited Allocated Volume
- Mass Budget
- Need for Reliability
- Cost & Schedule

Lambda-X adopts a proven **co-engineering approach and iterative process** to determine with its partners the optimal balance between performance, specifications, costs, and schedule.



Lambda-X Methodolgy

Lambda-x is a trusted and experienced technical advisor to **explore**, **co-create** and **de-risk** your optical system.



Wide range of optical technologies (deflectometry, microscopy, hyperspectral imaging, light scattering, tomography etc.)



Optical laboratory (equipped with various alignment, assembly and metrology tools)

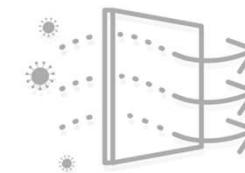

650 m² ISO 7 clean room facility (local areas in ISO 5)

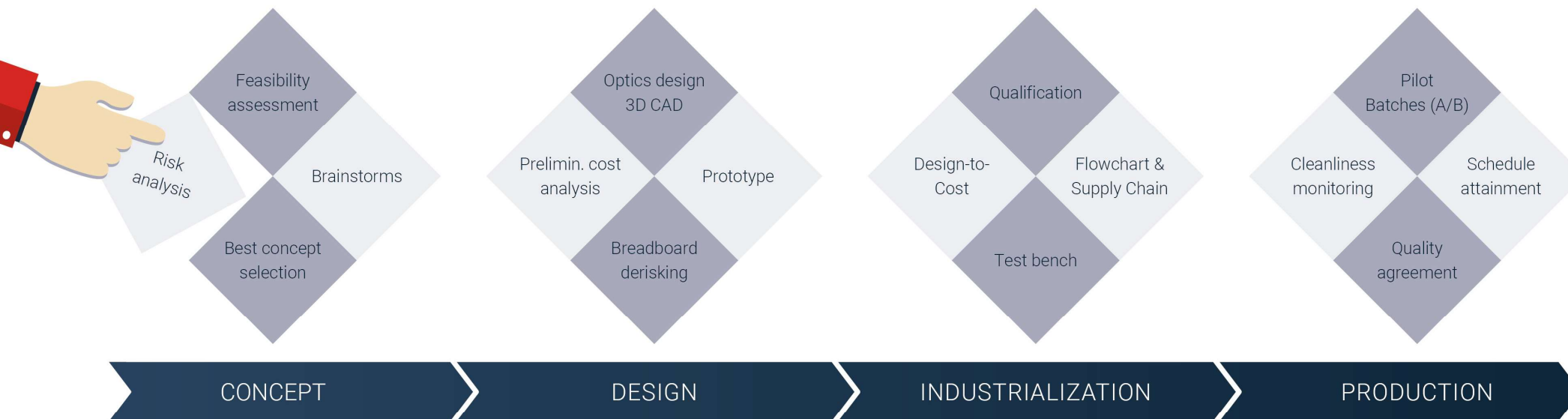

Space at Lambda-X High Tech

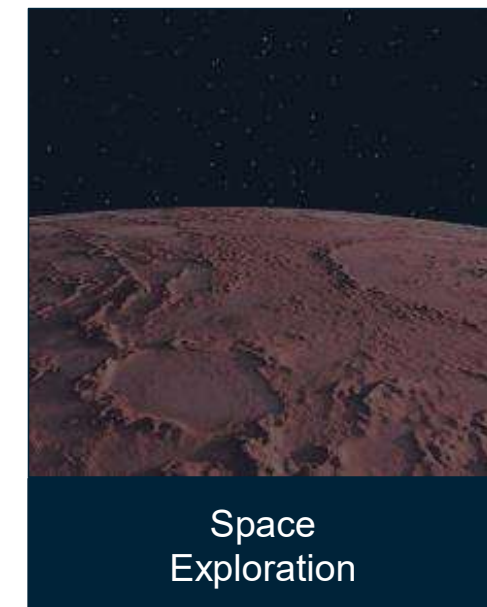
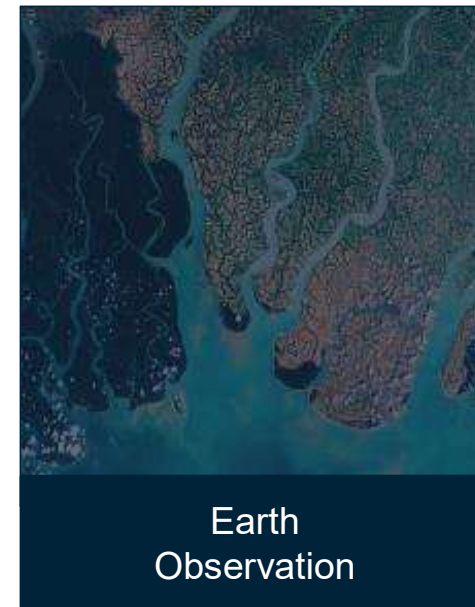
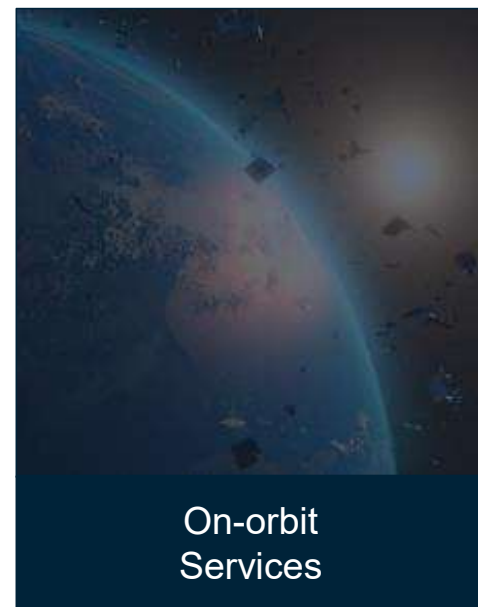
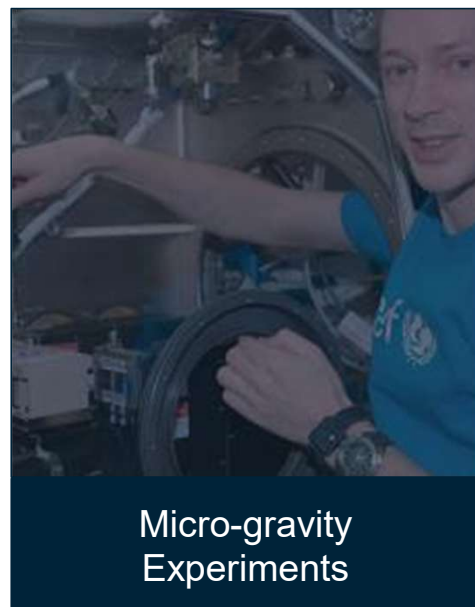

Selection of LX's Earth Observation Projects

CONFIDENTIAL

Earth Observation in Visible – CONAE Project

Project Goal: Developing a High Resolution Space Camera for ships detection in the darkness

Achieved activities by Lambda-X:

- ✓ Design & manufacturing of Visible Lens.
- ✓ Design & Manufacturing of Barrel & Mechanical Housing

Currently planned :

- Payload Integration & Alignment
- EQM Tests (including environmental tests)
- FM Tests (acceptance levels for environmental tests)

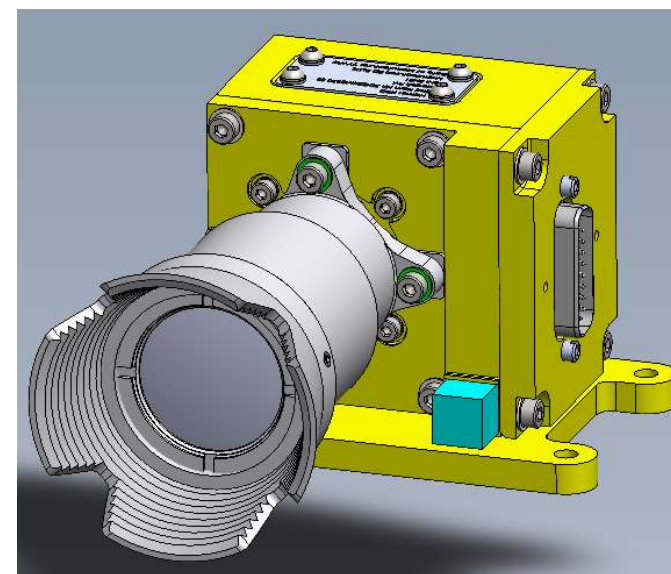
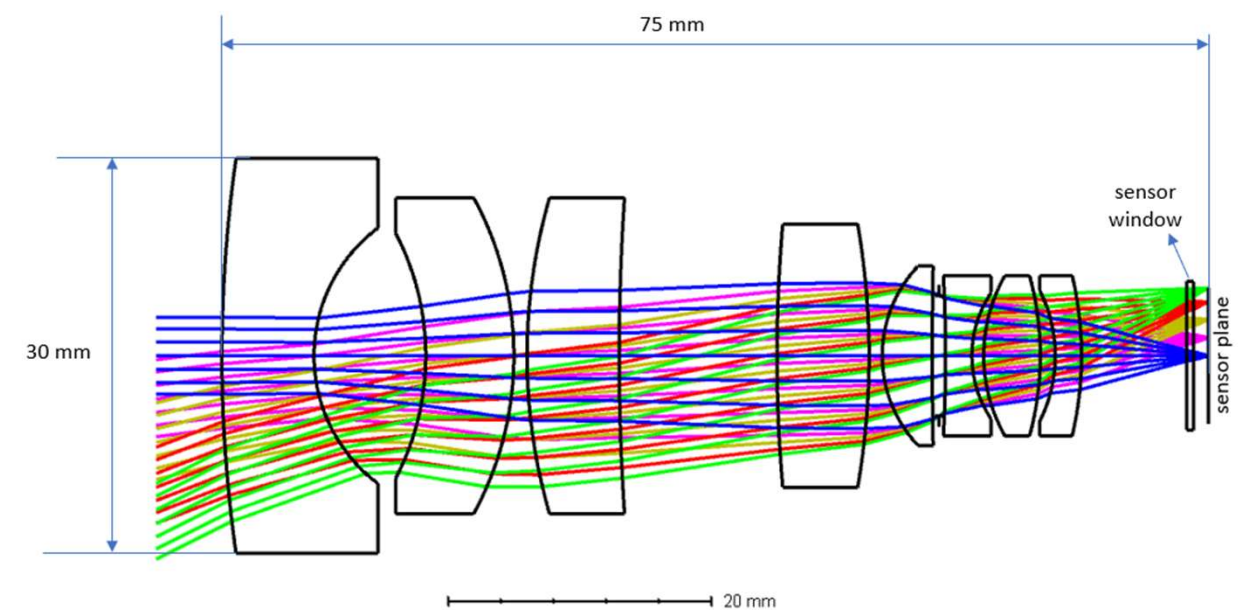

EQM DRB planned on Q3 2025

FM DRB planned on Q4 2025

Earth Observation – Thermal Infrared Payload – In Orbit Demonstrator #1

Payload for earth observation in the **long wavelength infrared (LWIR) spectral domain 8-14 μ m**.

Uncooled bolometer technology - ground sampling distance at 57m for a flight altitude of 450Km.

Achieved activities by Lambda-X:

- ✓ Design & manufacturing of IR Lens.
- ✓ Ruggedization of electronics hardware.
- ✓ On ground qualification for vibration & thermal vacuum environment.
- ✓ Demonstrator delivered.

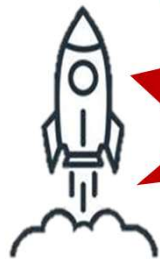
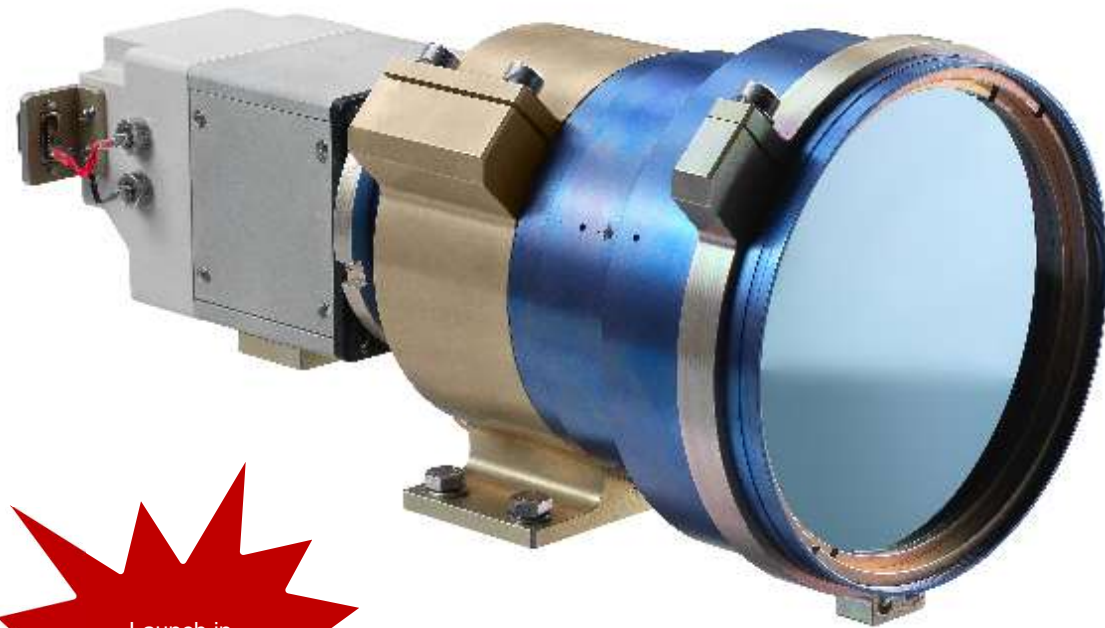

Launch in
January 2025

Earth Observation - Thermal Infrared Payload – In Orbit Demonstrator #2

Update of In Orbit Demonstrator #1

- Lens f-number: F#1
- Optics focal length: 75 mm
- Sensor: 1280*1024 pixels
- Max frame rate: 60Hz
- GSD @520Km: 83m
- Field of view: 11.7° x 9.4°
- Ground FOV: 85.2km (1024 pixels) - 106.5 km (1280 pixels)
- Operational temperature range: -40°C to +70°C
- Non-operational temperature range: -40°C to +85°C
- NETD : ~140mK @30Hz
- Current volume 151x 116 x 110 mm³
- Mass is less than 2Kg

Lambda-X's achieved activities:

- ✓ Design & manufacturing of IR Lens
- ✓ Optics calibration
- ✓ On ground qualification for vibration & thermal vacuum environment
- ✓ FM delivery



Project de-risked through **General Support Technology Programme (GSTP)** ESA in 03/2022

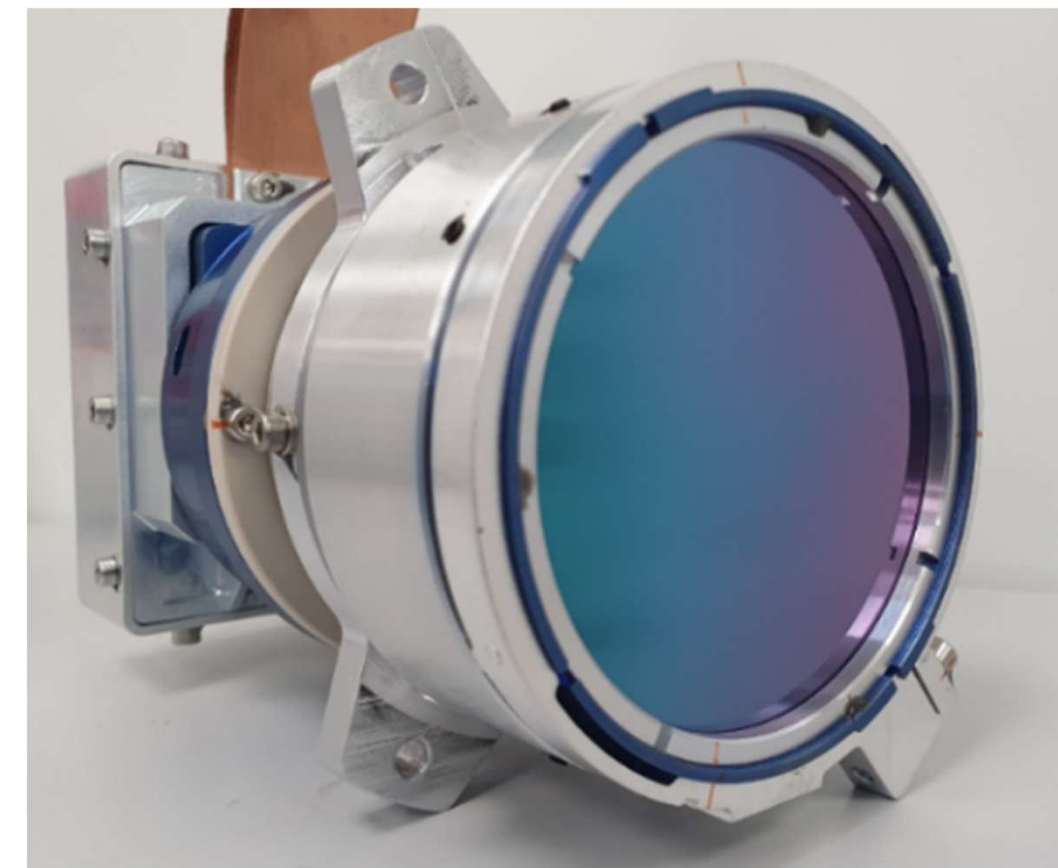

Earth Observation – Thermal Infrared Payload - In Orbit Demonstrator #3

In January 2023, Lambda-X signed a contract with an aeronautics, space, and defense research laboratory, which includes the participation to an *In-Orbit Demonstration Project*.

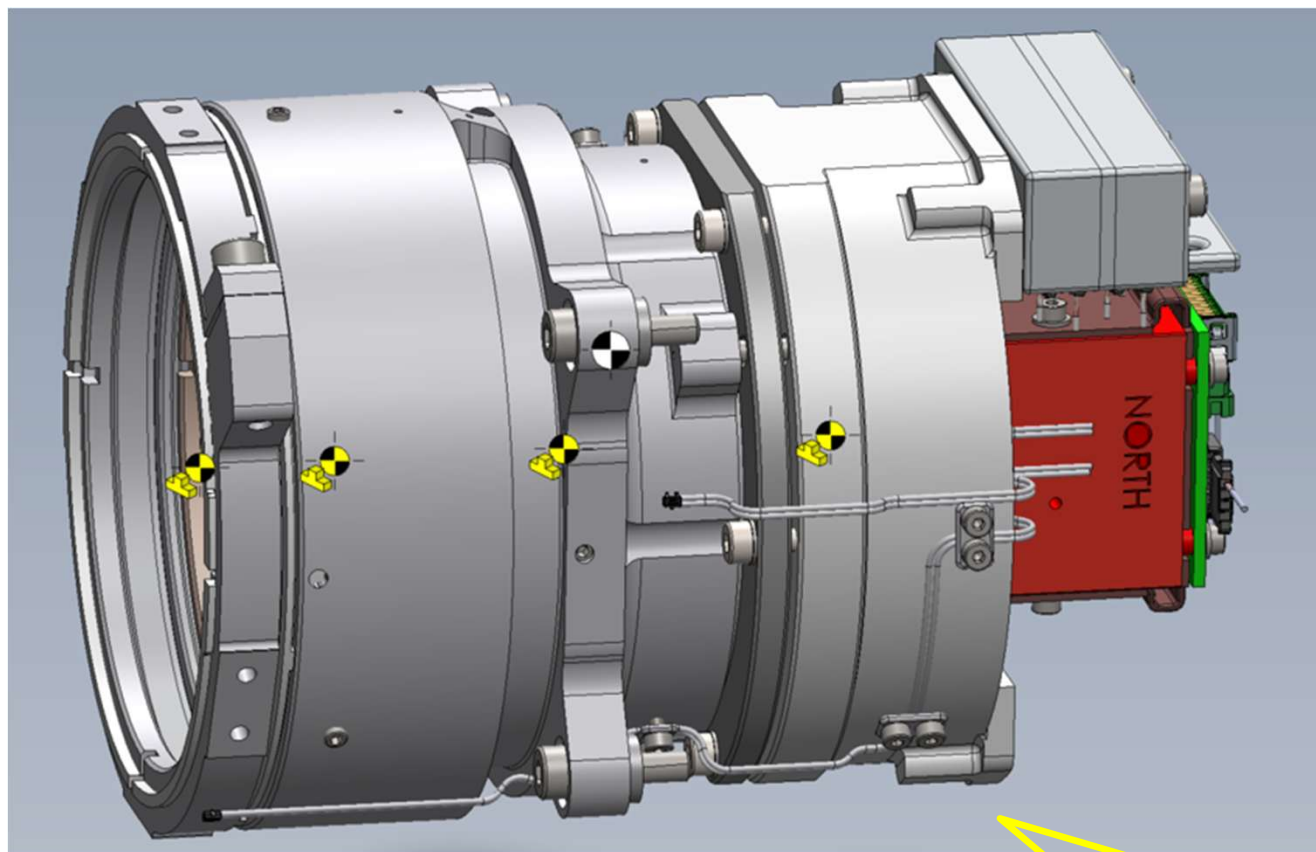

Two nanosatellites will be developed and launched in 2025. One will integrate an **observation system working in the thermal infrared spectral range** (making use of the ATTO 1280 sensor).

Lambda-X's tasks in the project:

- ✓ Design & manufacturing of IR Lens
- ✓ Optics calibration
- ✓ Vibration Testing



DRB EQM: 01/2025
DRB FM : 03/2025

Earth Observation – Methane Detection & Monitoring Payload

In June 2022 Lambda-X signed a contract with a French private company for the development of a **hyperspectral payload** aimed at detecting & monitoring methane in the **short wavelength infrared (SWIR)** and **Visible** spectral domain.

Lambda-X's tasks in the project:

- ✓ Instrument development
- ✓ Models production (STM, EQM, FM)
- ✓ Qualification & delivery

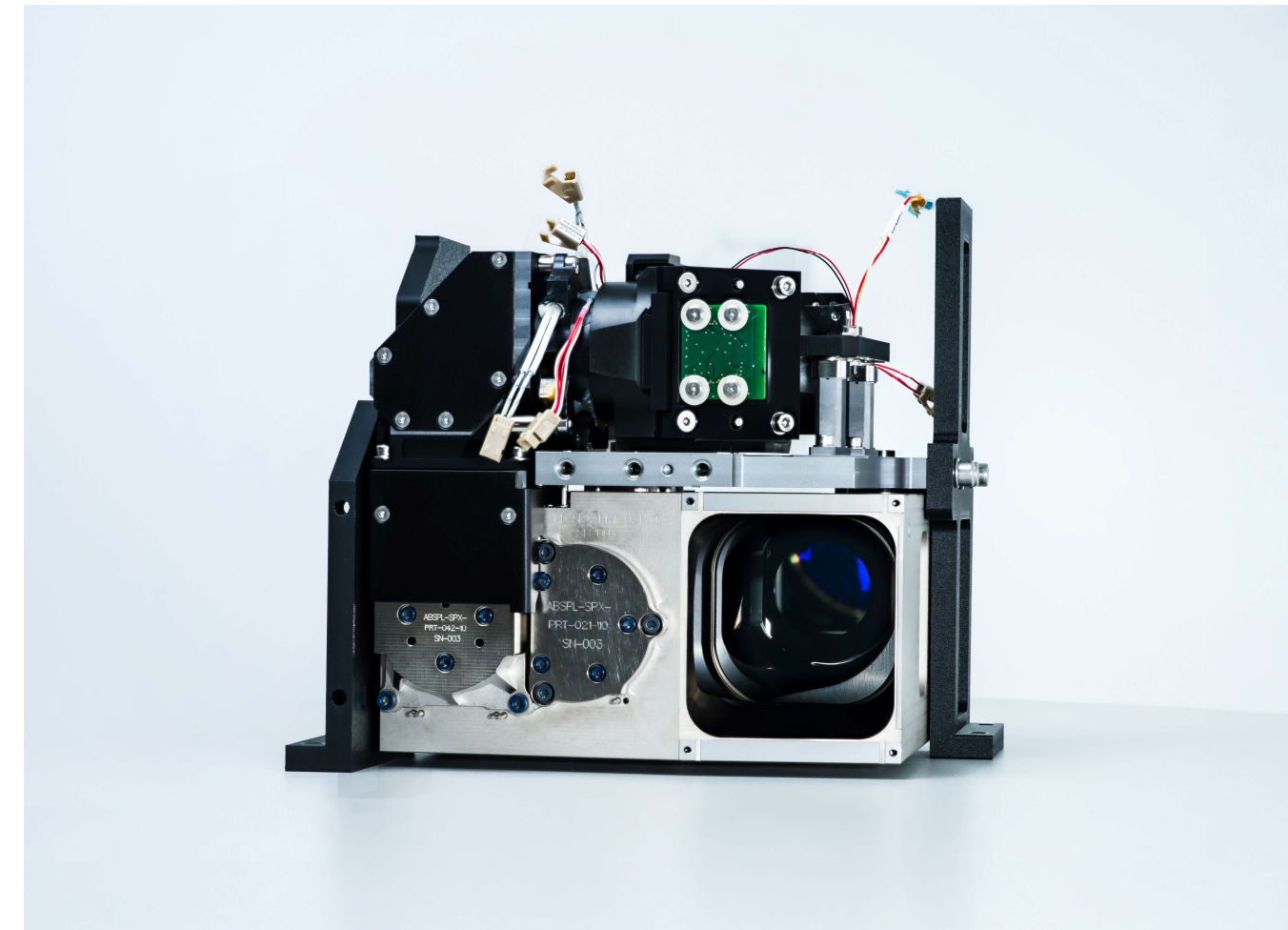
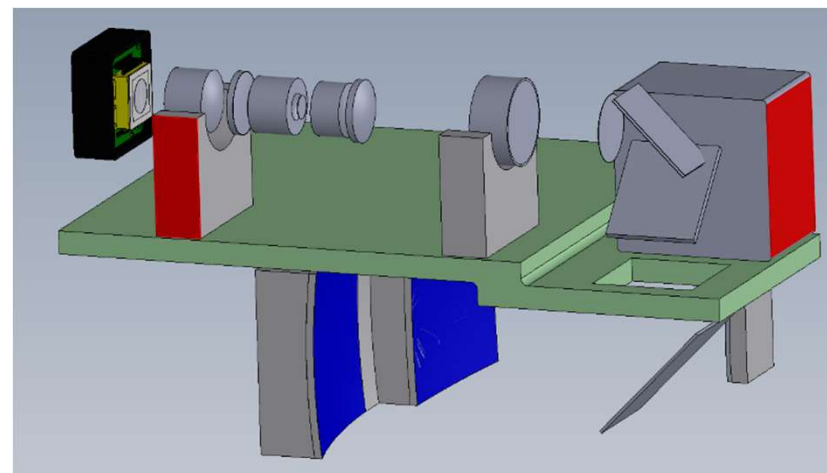

Earth Observation – SWIR Optical Payload

On going R&D Project, aiming at developing optical technologies for Earth Observation in the spectral range 900 – 1700 nm. The instrument shall provide a GSD of 18m at nadir working at 520 km orbit altitude (LEO).

Lambda-X's tasks in the project:

- ✓ Optical instrument development
- ❑ Models production
- ❑ Qualification & delivery

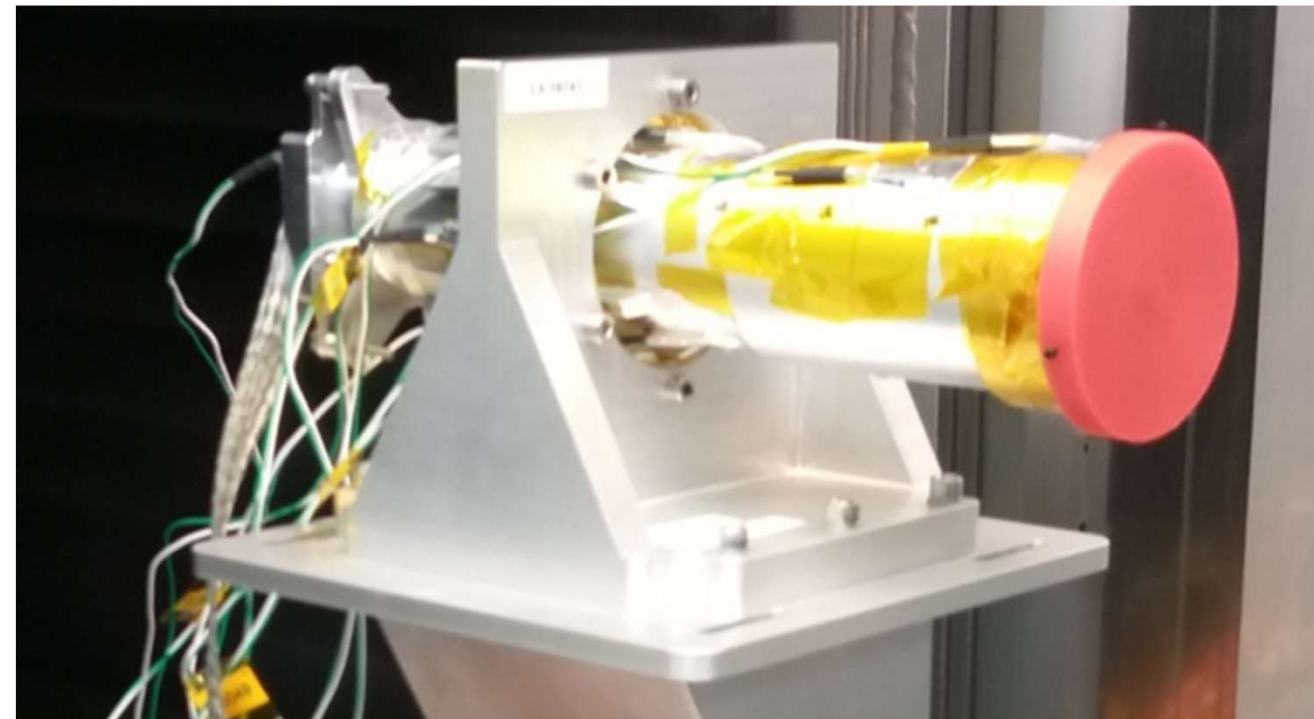

Selection of LX's On-Orbit Projects

CONFIDENTIAL

On-Orbit Services - Imaging Technologies – Platform monitoring

In the frame of ESA's JUICE (JU piter ICy Moons Explorer) Mission, Lambda-X has been selected for the design, manufacturing and test of **custom optics for the monitoring camera**.

Specifications:

FOV: 56°;
DoF: 2m to infinity at 65cy/mm
Volume: 4.5 x 5 x 5 cm³

Qualifications

Temperature: -40°C to 70°C
Radiation (40Mrad's!)

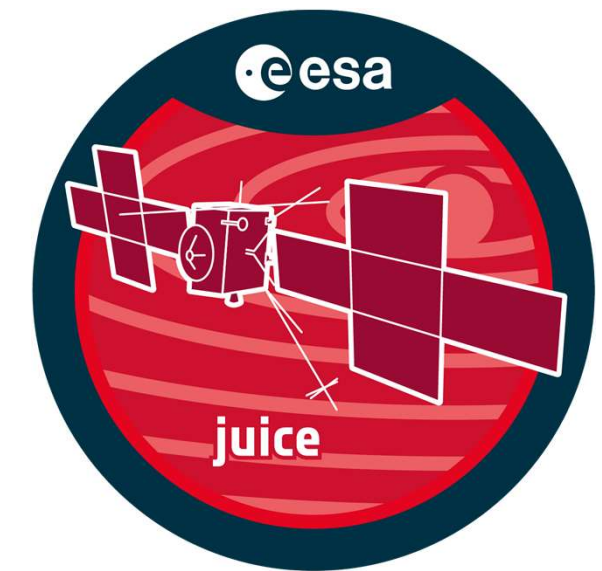

Achieved activities by Lambda-X:

- ✓ Design & manufacturing of the optics.
- ✓ Test campaign of the Qualification Model.
- ✓ Delivery of 5 Qualification & Flight Models

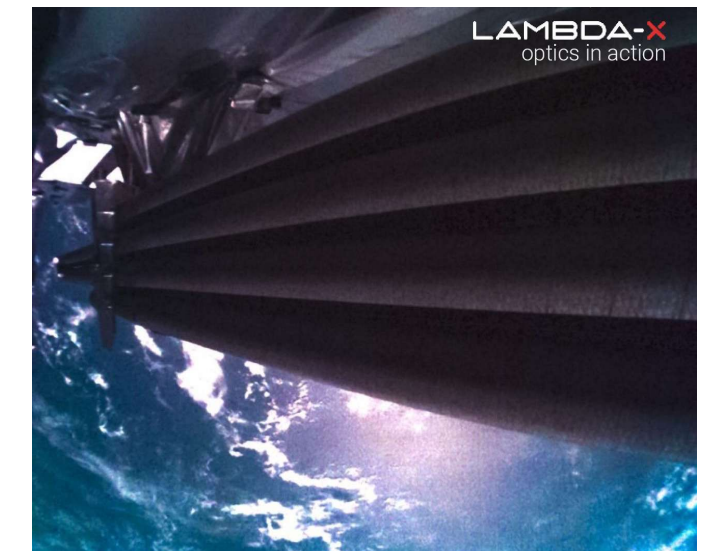

On-Orbit Services - Imaging Technologies – Platform monitoring



ESA's BIOMASS mission is designed to deliver crucial information about the state of our forests. In 2019, Lambda-X was selected for the procurement of **wide field angle optics** for the platform deployment. After the successful completion of the Critical Design Review (CDR) under the supervision of AIRBUS DS, the flight models were delivered in 2020.

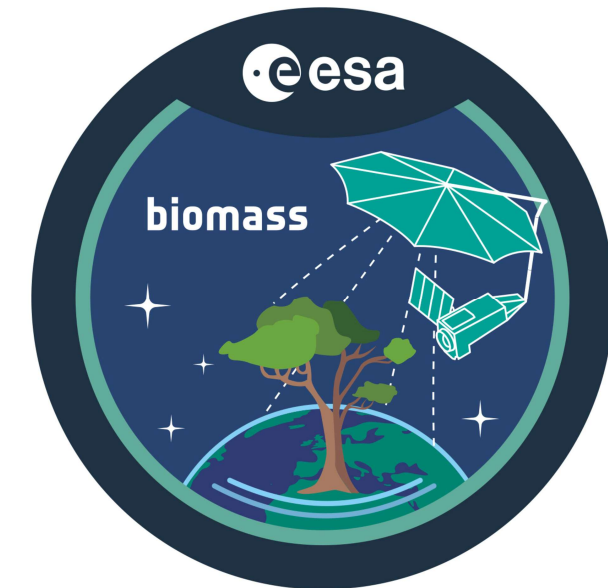

Achieved activities by Lambda-X:

- ✓ Design & manufacturing of the optics.
- ✓ Test campaign of the Qualification Model.
- ✓ Delivery of Qualification & Flight Models



On-Orbit Services/SSA - Imaging Technologies – Active Debris Removal

Payload Development for Active Debris Removal

In the frame of the mission ELSA-M, in 2022 Lambda-X has been commissioned the optics and the mechanical housing of the Visual Cameras A&B (**VISCAM**) aimed at :

- Guiding rendezvous & docking operations
- Supporting the safe and effective removal of failed satellites from orbit.

Lambda-X's achieved activities:

- ✓ Custom Optical Design
- ✓ Structural & Thermal Analysis
- ✓ Detailed Payload Design
- ✓ Procurement of Optical & Mechanical Parts

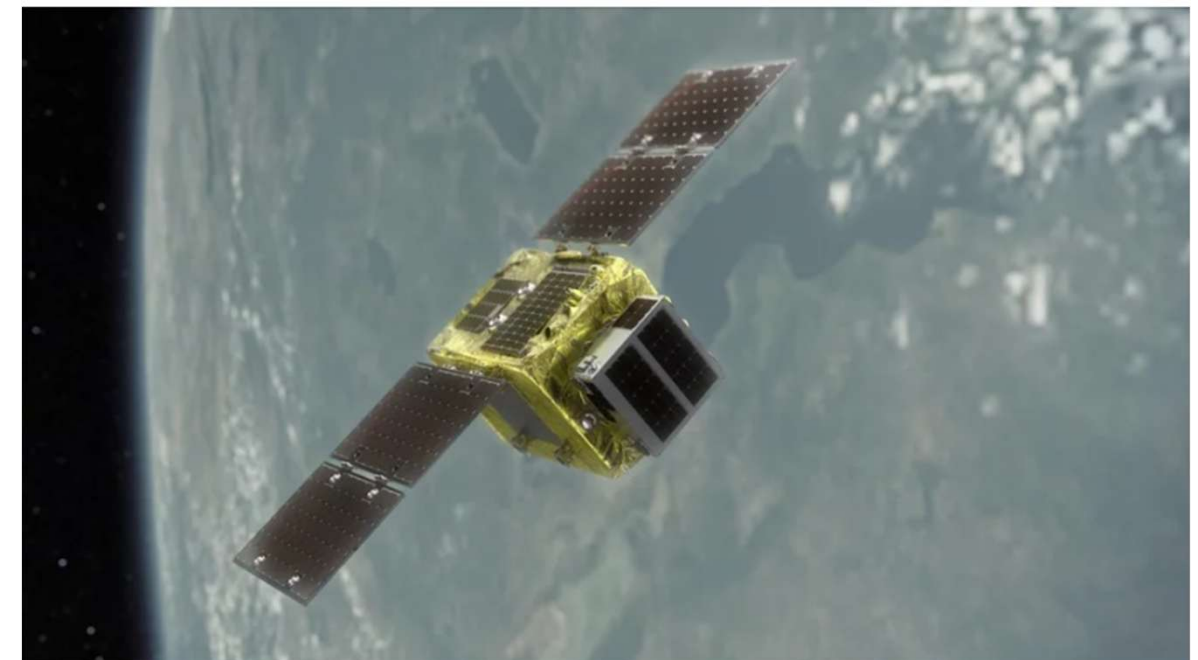

EQM have been delivered on February 2024 to Customer for Qualification

FM DRB has been done in June 2024

On-Orbit Services/SSA - Imaging Technologies – Satellite Inspector #1

Satellite Inspection Payload 1#

Private French SSA Company working on enhancing LEO sustainability, by identifying natural and human threats towards in-orbit assets.

Lambda-X's role in the project:

- Feasibility study based on Customer's specifications
- Co-definition of full project requirement trade-off
- Designing & manufacturing of the satellite inspector's optical system



Visible



Nominal Working Distance: 100 m
 Smallest Working Distance: 50 m
 Largest Working Distance: Infinity



Max. 2kg
 NTH <1.5 kg

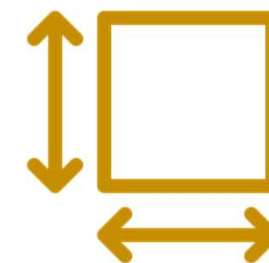

80 x 80 x 170 mm

On-Orbit Services/SSA - Imaging Technologies – Satellite Inspector #2

Satellite Inspection Payload 2#

In 2024 Lambda-X signed a contract with a European Mission Provider for the development (phases C/D) of a satellite inspection payload in two spectral ranges:

- Visible
- SWIR

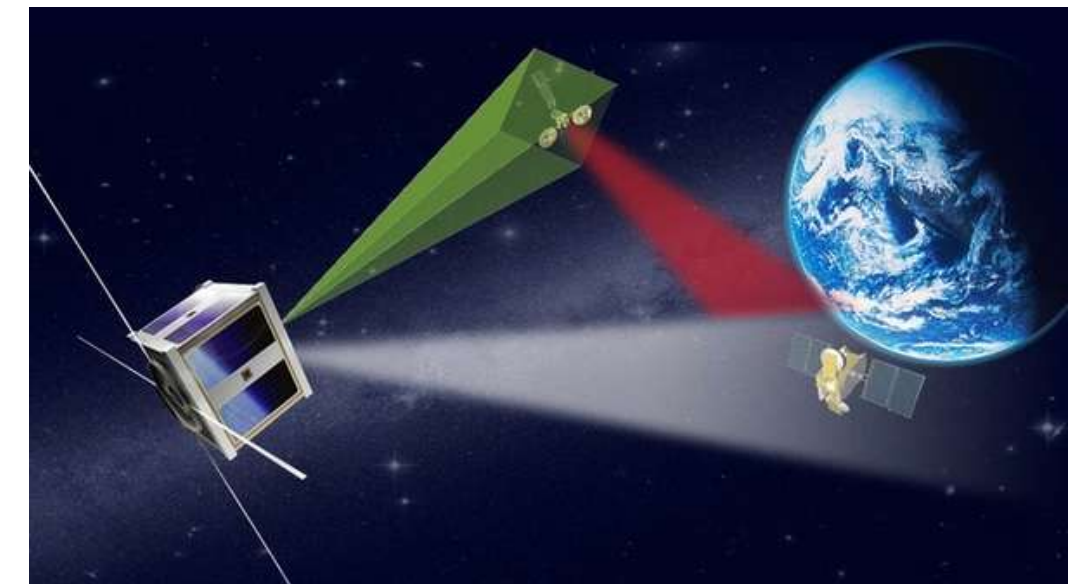

Lambda-X's achieved activities:

- ✓ Co-engineering Phase (up to PDR)
- ❑ EM & PFM Manufacturing & Tests

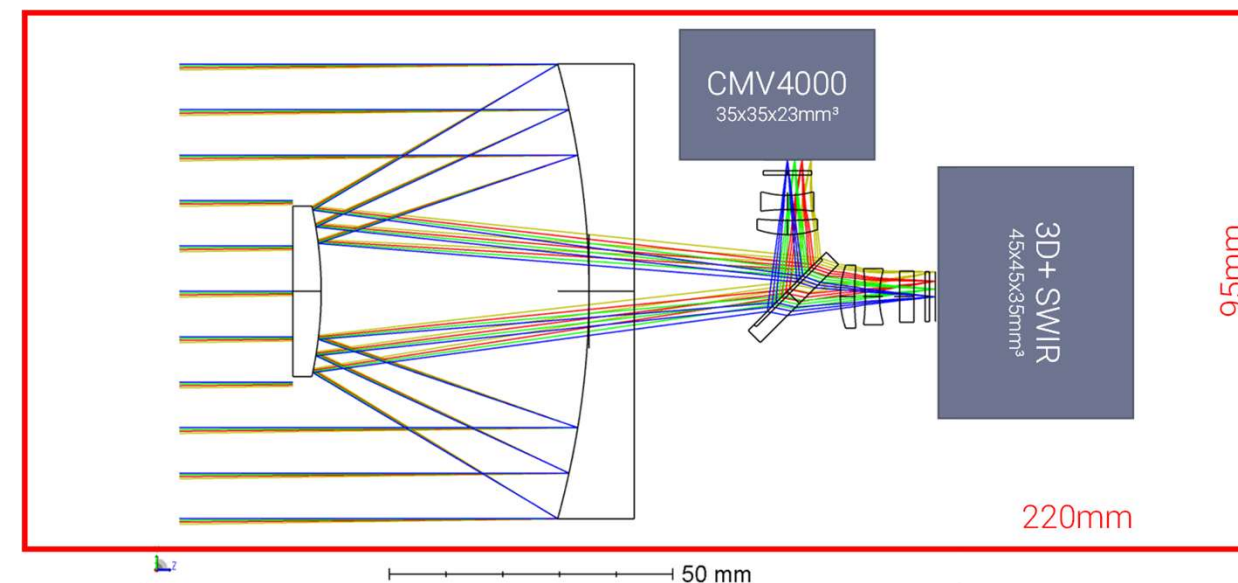

DEFENSE at Lambda-X High Tech – STAALION

Space Threats Analysis based on Automated real-time In-situ capabilities and Onboard processing decentralized Network

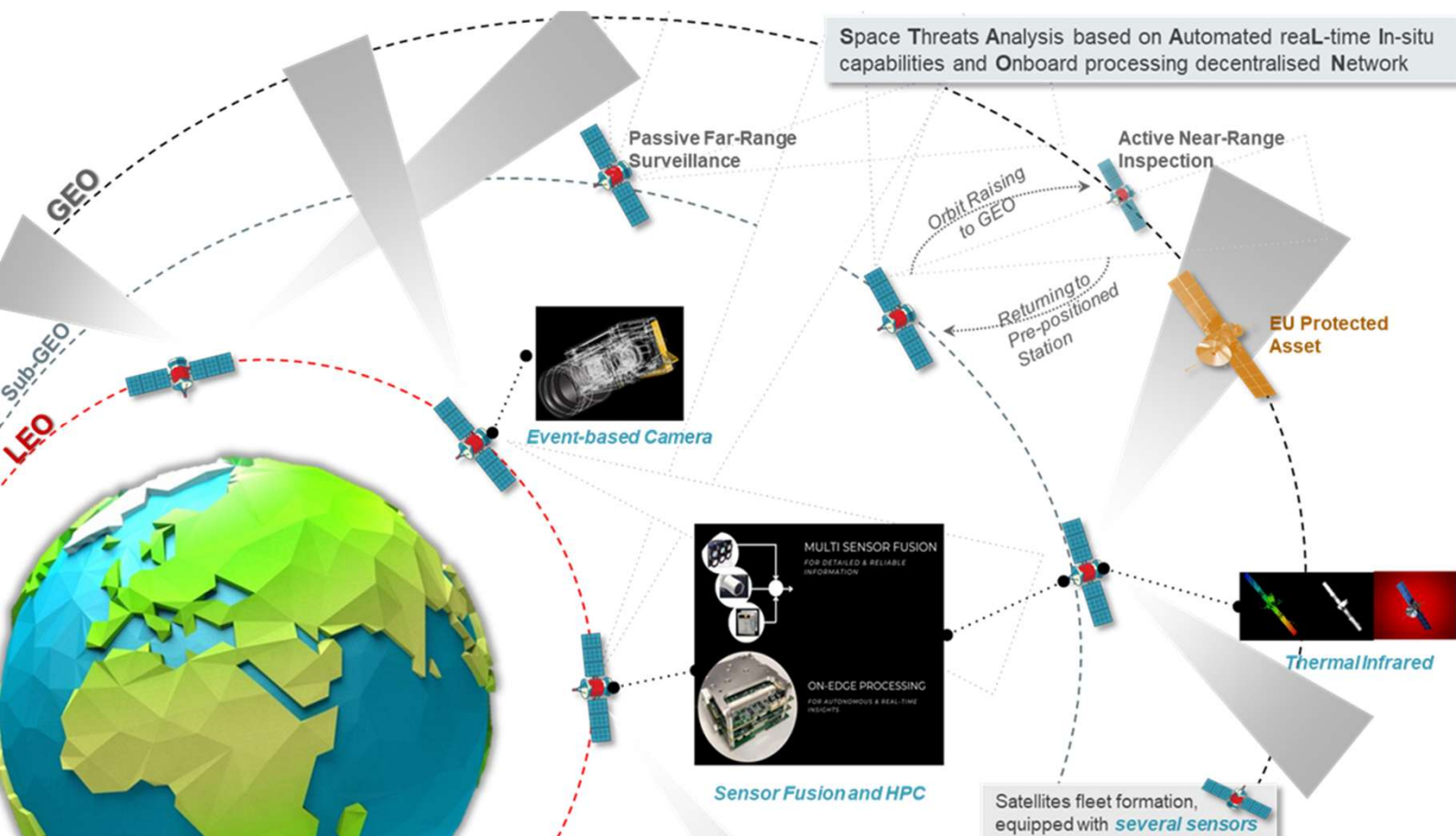

Objective: demonstrate potential performances of In-Situ Space Domain Awareness.

Scope: Fleet of satellites equipped with **multiple sensors to detect, identify, characterize & track threats for European space assets.** On-edge processing to perform **on-board analysis.** Development of **effective algorithms** for anomaly detection, including manoeuvres, new object insertions, and close approaches.

Lambda-X High Tech: Thermal Infrared Imagery, Lens Design.

Selection of LX's Space Exploration Projects

CONFIDENTIAL

Space Exploration – PROSPECT

Package for resource observation, in-situ analysis and prospecting for exploration commercial exploitation and transportation



The project includes an Imaging System to deliver images of drilling and sampling operations. In collaboration with 3D PLUS, **Lambda-X** is responsible for the **Camera Optics development & manufacturing.**



Space Exploration – MMX (Martian Moons eXploration)

MMX is a robotic space probe set for launch in 2024 to bring back the first **samples** from **Mars'** largest moon **Phobos**.



The same designed was also used for the **LUDEAU camera** destined to the Moon.

3D PLUS assigned to Lambda-X the manufacturing tasks for the optical assembly batch of **MMX NavCam cameras with wide FoW**. The project also includes the design and manufacturing of related the mechanical interfaces between each optical assembly and 3D PLUS sensor.



MSR: Deliver samples collected by the Mars Perseverance rover to Earth

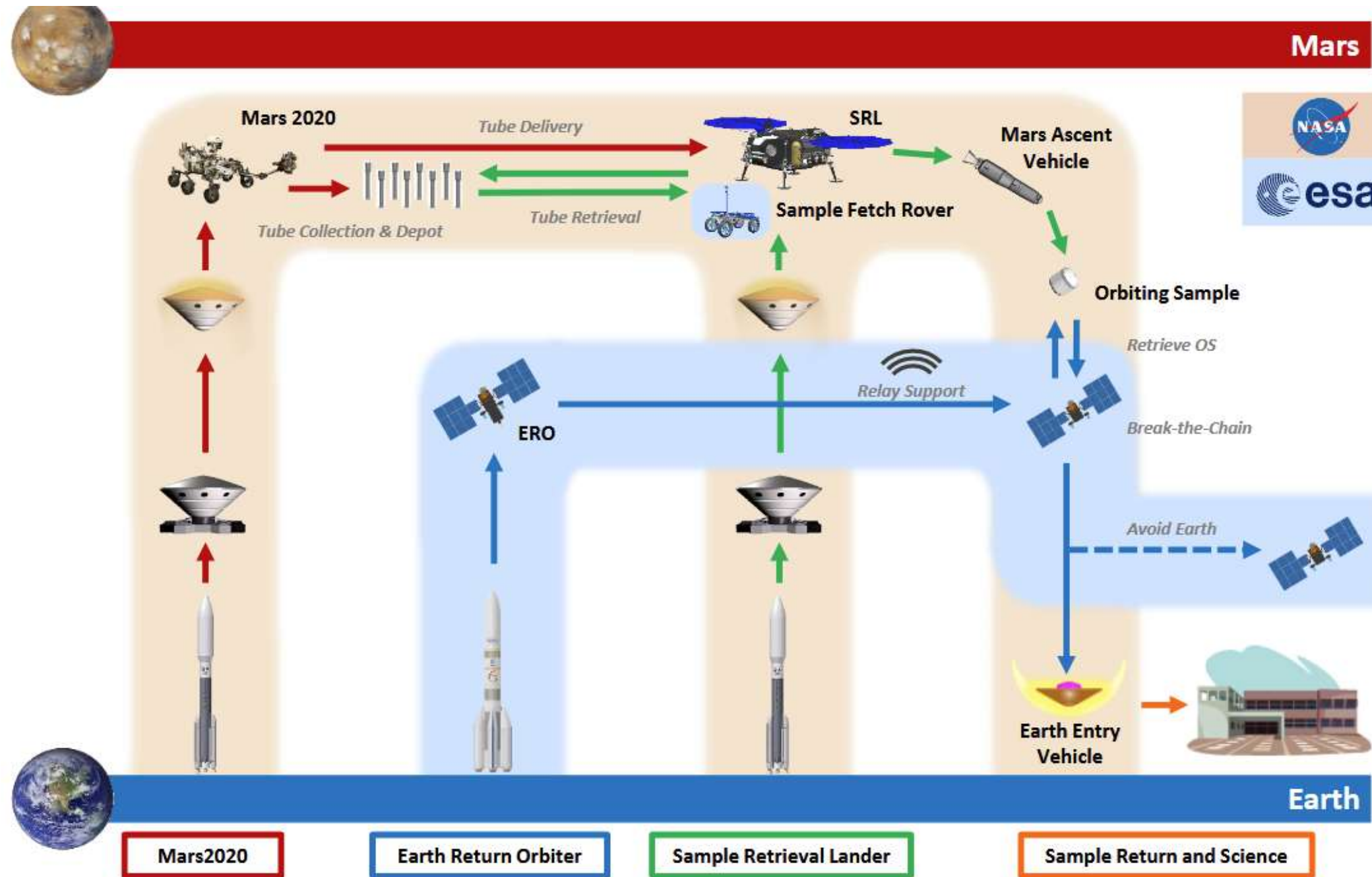

Space Exploration – MSR – ERO – MCOH

The Mars Sample Return (MSR) mission is an ambitious, multi-part project aimed at collecting samples from Mars and returning them to Earth for analysis.

Earth Return Orbiter (ERO): This spacecraft is responsible for traveling to Mars, capturing the sample container launched from the Martian surface, and returning it to Earth.



Lambda-X was chosen by the 3D PLUS & AIRBUS DS consortium to supply the objective lens for integration into the **Monitoring Camera Optical Head (MCOH)**. In this project, Lambda-X is responsible for both the design and manufacturing of the lens as well as the Camera Mechanical Housing.

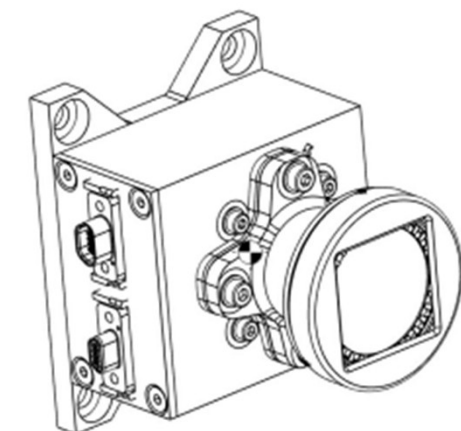

Space Exploration – MSR – STA

The Mars Sample Return (MSR) mission is an ambitious, multi-part project aimed at collecting samples from Mars and returning them to Earth for analysis.

Sample Transfer Arm (STA) Its main function is to transfer the sample tubes from the Perseverance rover to the Mars Ascent Vehicle, which will then launch them into Mars orbit for collection by the ERO.



Lambda-X was chosen by the 3D PLUS to deliver the optical technology (using the PROSPECT configuration) for a **camera** aimed at **guiding the STA operations**.

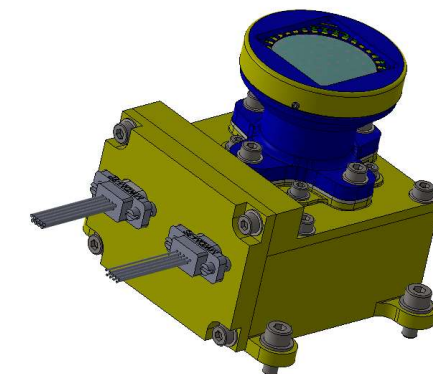

Contacts



Fabrizia Candido

Business Development Manager Space & Defence

fcandido@lambda-x.com

+32 67 47 57 48

+32 471 51 58 53



Jean-Hervé Lecat

Business Develop. Manager Space & Defence

jhlecat@lambda-x.com

+32 67 47 57 27

+32 499 93 02 37

Our pitch

Let's boost your capacity to innovate a better world

Ever wanted to innovate for a better world? Since 1969, we've been all about using innovation to level up everyday solutions. But let's be real, it's tough. That's why we help to boost your innovation capacity, turning game-changing ideas into reality. It's all about multidisciplinary teams of smart minds, design thinking, and breakthrough tech.

We're an innovation company, here to power your new products, services and business. Trusted by front-running corporations and start-ups throughout Europe, admired by our users and peers. Why? With 5 specialized business units, we co-create innovation, forming your end-to-end innovation factory together. Welcome to the sweet spot of innovation.

Koen Verhaert
CEO

