

# Test Solutions

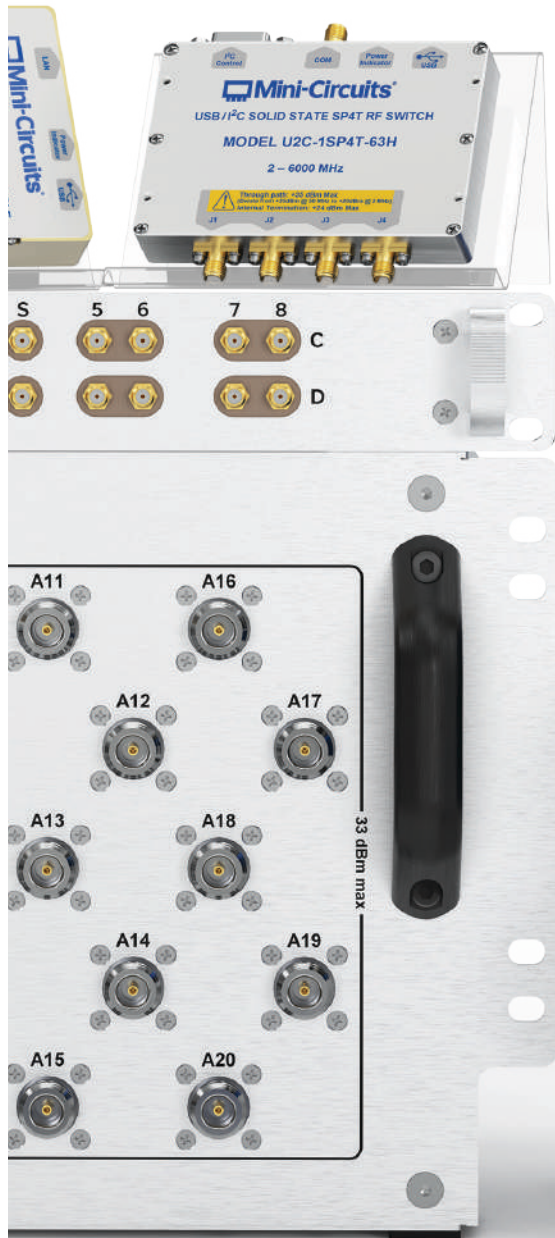

## PRODUCT LINE OVERVIEW

# Get More Out of Your Test Setup

Equipment for test and measurement is one of the largest investments for most companies developing RF/microwave products. The capability to test many devices quickly and reliably can greatly reduce overall production cost and time to market, and a powerful test setup can be a significant competitive advantage. As new applications require more advanced measurements and migrate to higher frequency bands, high-end test instrumentation can run well into the six-figure range, which presents a high barrier to increasing test throughput.

But developing a fast, efficient test setup or expanding capacity of your existing setup needn't require prohibitive cost. Mini-Circuits has developed a line of innovative products to help customers get more out of their test setups by

integrating functions of switching and routing, attenuation, signal generation, sensing and more. Depending on the application, these functions may be used as standalone solutions off the shelf or easily integrated to build scalable, automated testing platforms customized to each user's individual needs. Our test solutions are easy to control via USB, Ethernet and a variety of other convenient interfaces, and our complete software package gives you the ability to plug and play right out of the box, or develop your own software.

Mini-Circuits has successfully helped hundreds of customers improve efficiency and reduce cost in their test operation, and we hope the information in this guide gives you some ideas about how we can help you do the same.



# The Mini-Circuits Difference

## Flexible

Every test application is unique. At Mini-Circuits, our wealth of components in stock allows us to take a building-block approach to developing systems that meet the specific needs of each test setup. From off-the-shelf components and modules to turnkey custom builds, our solutions give you all the functions you need with the flexibility to scale and modify your stack as your needs evolve over time.

- Wide variety of components in stock from DC to 67 GHz
- Off-the-shelf, DIY kits, modular and custom options
- Flexible hardware, software and firmware
- Expand and reconfigure as your needs change

## Reliable

When you work with Mini-Circuits to expand your test setup, you're getting the assurance that comes with 50+ years of quality management experience. All our test solutions come fully tested and characterized by our team in house, and meet the rigorous standards that have earned the industry's trust since 1968.

- All components and assembled systems tested and characterized in-house
- Rugged designs for demanding lab and production environments
- Award-winning quality excellence

## Affordable

Most high-end test equipment comes at a heavy premium for dozens of advanced features that many users don't need. Mini-Circuits test solutions give you the high-performance and functionality you need to get more out of your test setup without the heavy capital expenditures.

- Get more functionality and capacity out of your existing instrumentation
- High-performance custom systems without breaking the bank
- Save cost on extra features you don't need

## Fast

We know the turnaround time on custom test equipment directly affects your time to market. That's why we put the full capability of our manufacturing and supply chain organizations behind our test solutions to make speed a competitive advantage. Mini-Circuits offers some of the fastest turnaround times on custom test equipment in the industry.

- Wide selection of models in stock for immediate shipment
- Modular systems for quick, user-defined configuration
- Established process for custom designs refined over hundreds of successful projects

<b>PRODUCT LINE OVERVIEW</b> .....	<b>07-08</b>
<b>CUSTOM SYSTEMS</b> .....	<b>61</b>
<b>INTEGRATED AMPLIFIERS</b> .....	<b>43-45</b>
<b>LAB ACCESSORIES</b> .....	<b>61-66</b>
<b>MEASUREMENT</b> .....	<b>47-53</b>
Power Sensors .....	51-53
Signal Generators .....	53
<b>PANEL MOUNTED STRUCTURES</b> .....	<b>55-58</b>
Patch Panels .....	56
Passive Component Panels .....	57-58
<b>SIGNAL CONDITIONING &amp; ATTENUATORS</b> .....	<b>29-34</b>
Programmable Attenuators Off the Shelf .....	29-31
Multi-Channel Attenuators Off the Shelf .....	32
Rack-Mount Attenuation Systems .....	33-34

**SIGNAL DISTRIBUTION** ..... 59-60

**SWITCHING & ROUTING** ..... 09-29

Mechanical Switch Boxes ..... 11-12

Modular Switch Systems ..... 13-14

Mechanical Switch Arrays ..... 15-16

Solid State Switches ..... 17-18

Solid State Switch Racks ..... 19-20

**Switch Matrices** ..... 21-28

    Non-Blocking ..... 22-23

    Blocking ..... 24-26

    Full Fan-Out Matrices ..... 27-28

**TARGETED SOLUTIONS & USE CASES** ..... 35-42

Cellular Handover Test Systems ..... 35-36

Mesh Network Simulation Racks ..... 37-38

High Power Test Systems ..... 39-42

# Personal Engineer-to-Engineer Support

Customers choose Mini-Circuits because they know they're getting quality and performance they can count on. But what really sets us apart is our close collaboration with customers at the engineering level from definition to delivery.

The specifications for many systems are often defined concurrently with the design process, and customers look to us to partner with them in making their projects successful. That means we need the competence and expertise to understand your needs, and the agility in our processes design and assemble a diverse range of user-defined solutions on a tight timeline.

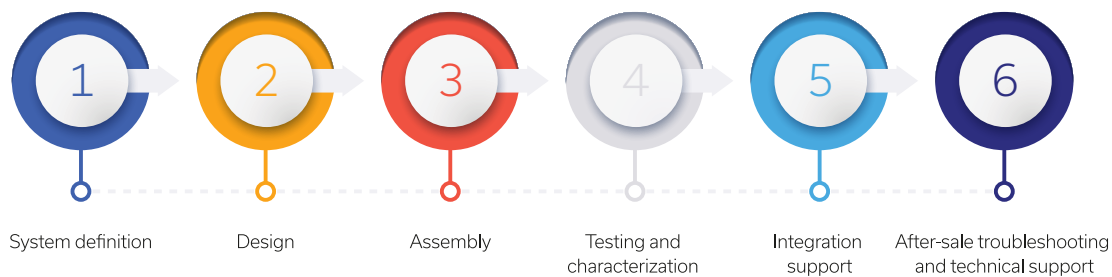

# Our Software or Yours

## Plug and Play

### Mini-Circuits' User-Friendly GUI Software

All Mini-Circuits test solutions come ready to use out of the box with our user-friendly GUI software for Windows® systems. Just install the software package on your PC, connect to the unit via USB or LAN and get to work. Mini-Circuits' GUI program gives you manual control over the hardware with a simple point-and-click interface as well as the ability to automate sequences for your test flow.



### Software Highlights:

- LAN interface for remote control over a network
- SSH support for secure communications with MCL products over a network
- USB interface for local PC control
- Automate switching attenuation and measurement functions from any common programming environment
- LabVIEW, Matlab, Python, C#, C++, VB supported.
- Simple "point and click"
- control using MCL user-friendly GUI

## Integrate with Your Native Test Software

### Full API and Programming Instructions

For users already working with Python, LabVIEW® or other popular test software, we provide a full API with programming instructions for Windows and Linux® environments with every system. This way you have the option to write your own program and integrate your Mini-Circuits hardware seamlessly with the rest of your test setup.

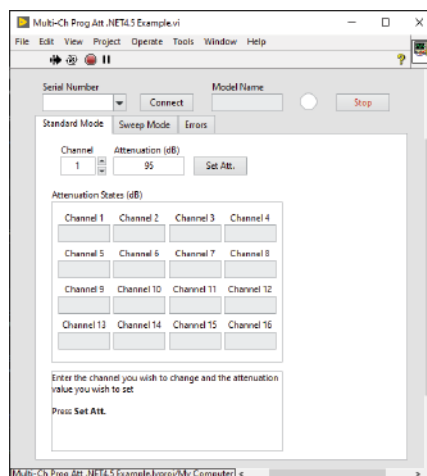

# Switching & Routing

Managing signal traffic between measurement instrumentation and multiple devices under test (DUTs) is one of the most common needs in all lab environments. Mini-Circuits offers a full range of solutions for switching and routing, whether you're looking for complex, integrated switch matrices, simple benchtop switch modules, or discrete mechanical and solid-state switches to assemble yourself.

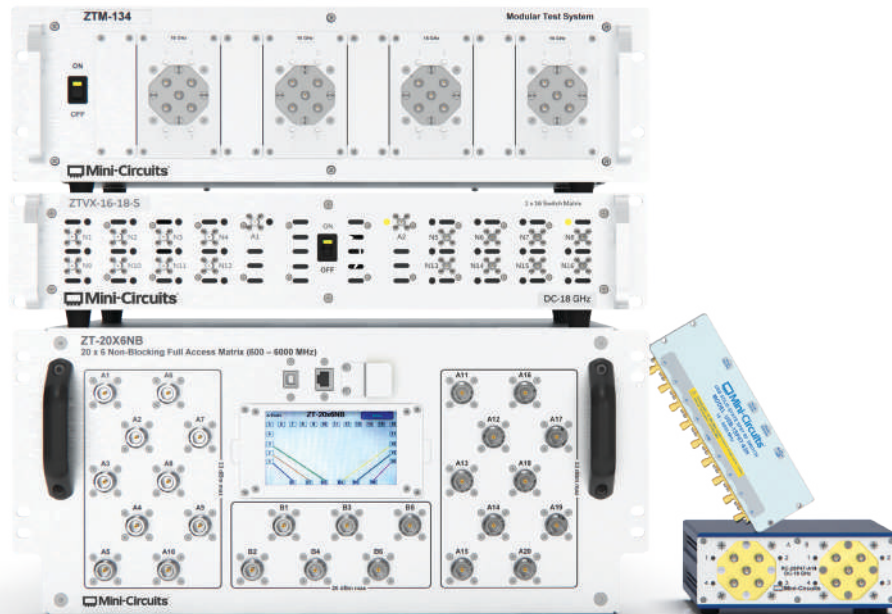
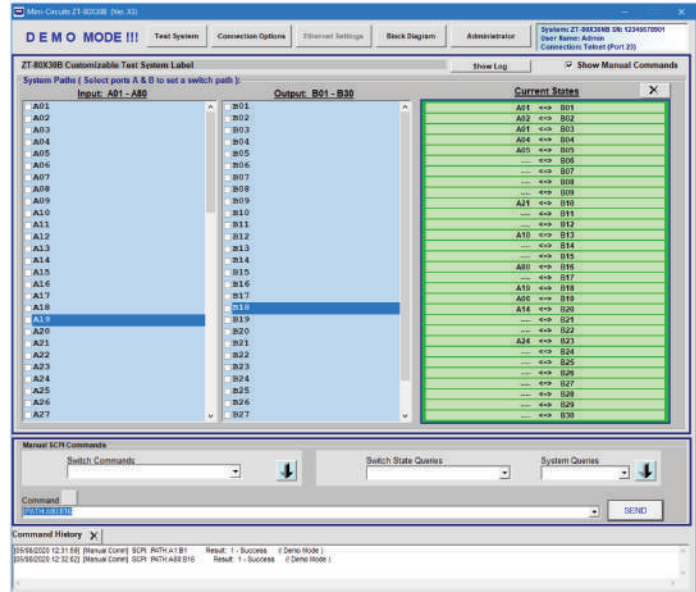



### Options for Every Requirement:

- Mechanical switch boxes from stock
- Modular switch systems
- Rack mount mechanical switch arrays and switch matrices
- Solid state switch systems
- Custom switching systems

# Mechanical Switch Boxes

## Overview

Mini-Circuits' compact RC- and RCM-series USB- and Ethernet-controlled switch boxes offer versatile high-performance mechanical switch systems for lab and production environments. A wide range of switch options are available from stock, from SPDT to SP8T, with frequency ranges up to 50 GHz. Each switch box is integrated with a robust controller supporting Ethernet & USB interfaces. Our electromechanical switches offer exceptionally wide bandwidths with low insertion loss, high isolation and high power ratings, ideal for test and automation applications.

## Key Benefits

- Typically available from stock for immediate shipment
- Affordable solution for a wide range of signal routing and test requirements
- Small size for almost any lab environment

Catalog Models						
Model Number	Switch Type	Frequency	Switch Count	Termination	Connector	
RCM-3SPDT-75F	SPDT	DC-2150	3	Terminated	F-type (75Ω)	
RC-2MTS-12N	DPDT	DC - 12 GHz	2	Transfer	N-type	
RC-1SP6T-A12	SP6T		1	Terminated	SMA	
RC-2SP6T-A12			2	Terminated	SMA	
RCM-1SP8T-12	SP8T		1	Terminated	SMA	
RCM-2SP8T-12			2	Terminated	SMA	
RC-2MTS-18	DPDT	DC - 18 GHz	2	Transfer	SMA	
RC-3MTS-18			3		SMA	
RC-1SPDT-A18	1		SMA			
RC-2SPDT-A18	2		SMA			
RC-4SPDT-A18	SPDT		4	Terminated	SMA	
RCM-6SPDT-18			6		SMA	
RC-8SPDT-A18			8		SMA	
RC-1SP4T-A18	SP4T		1	Terminated	SMA	
RC-2SP4T-A18			2		SMA	
RCM-3SP4T-18			3		SMA	
RC-1SP6T-A18	SP6T		1	Terminated	SMA	
RC-2SP6T-A18			2		SMA	
RC-2MTS-26	DPDT		DC - 26.5 GHz	2	Transfer	SMA



## Catalog Models Continued

Model Number	Switch Type	Frequency	Switch Count	Termination	Connector
RC-3MTS-26	DPDT	DC - 26.5 GHz	3	Transfer	SMA
RC-1SPDT-A26			1		SMA
RC-2SPDT-A26	SPDT		2	Terminated	SMA
RC-4SPDT-A26			4		SMA
RC-8SPDT-A26			8		SMA
RC-1SP4T-26	SP4T		1	Terminated	SMA
RC-2SP4T-26			2		SMA
RC-1SP6T-26	SP6T		1	Terminated	SMA
RC-2SP6T-26			2		SMA
RCM-1SP8T-26	SP8T		1	Terminated	SMA
RCM-2SP8T-26			2		SMA
RC-2MTS-40	DPDT		DC - 40 GHz	2	Transfer
RC-3MTS-40		3			2.92 mm
RC-2SPDT-A40		2			2.92 mm
RC-4SPDT-A40	SPDT	4		Terminated	2.92 mm
RC-8SPDT-A40		8			2.92 mm
RC-2SPDT-40		2		Unterminated	2.92 mm
RC-4SPDT-40	SP4T	4			2.92 mm
RC-1SP4T-40		1		Terminated	2.92 mm
RC-2SP4T-40		2			2.92 mm
RC-1SP6T-40	SP6T	1		Terminated	2.92 mm
RC-2SP6T-40		2			2.92 mm
RC-2SP6T-40R		2		Unterminated	2.92 mm
RC-2MTS-50	DPDT	DC - 50 GHz	2	Transfer	2.4 mm
RC-3MTS-50			3		2.4 mm
RC-2SPDT-50			2		2.4 mm
RC-4SPDT-50	SPDT		4	Unterminated	2.4 mm
RC-8SPDT-50			8		2.4 mm
RC-1SP4T-50	SP4T		1	Terminated	2.4 mm
RC-2SP4T-50			2		2.4 mm
RC-1SP6T-50	SP6T		1	Terminated	2.4 mm
RC-2SP6T-50			2		2.4 mm

# ZK Series –Mechanical Switches with TTL Control

## Overview

Mini-Circuits' ZK-Series is a portfolio of ultra-reliable electro-mechanical switches operating over a wide bandwidth from DC to 18 GHz with high isolation and low insertion loss. The switch is absorptive and fail-safe with a break before make configuration and lifetime of 5 million switching cycles when

used within the noted specifications. Simple control via TTL voltage levels allows integration with a wide range of microcontroller, embedded or custom systems without the additional complexity of USB or Ethernet control from a PC.

## Key Features:

- High performance mechanical switches for lab & production
- Compact & rugged package
- Ethernet & USB with API for simple automation
- Switch configurations from SPDT to SP8T
- Frequency coverage from DC to 18 GHz
- SMA connectors
- LED switch state indicators
- Low insertion loss, high isolation and high-power ratings

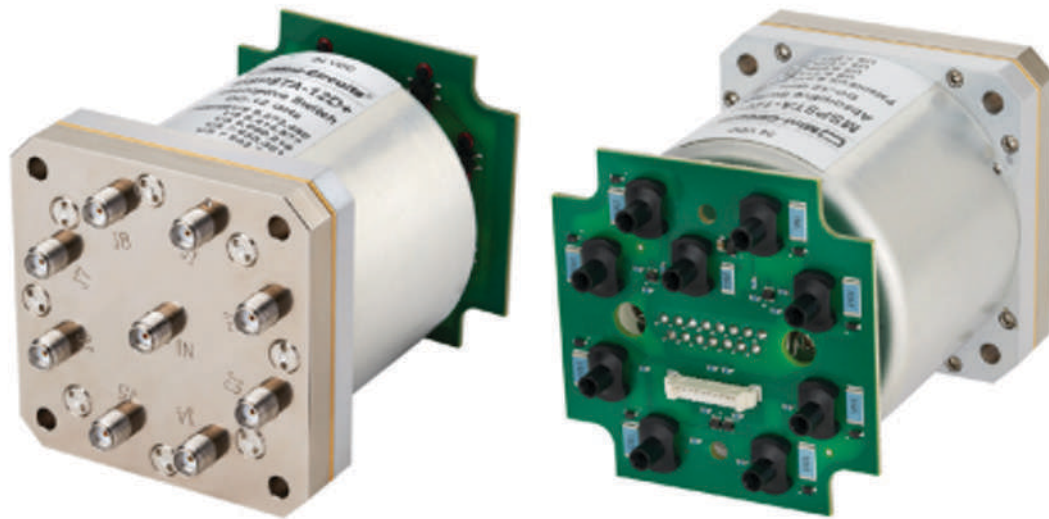

Front View

Back View

Generic photo used for illustration purposes only

### FUNCTIONAL BLOCK DIAGRAM

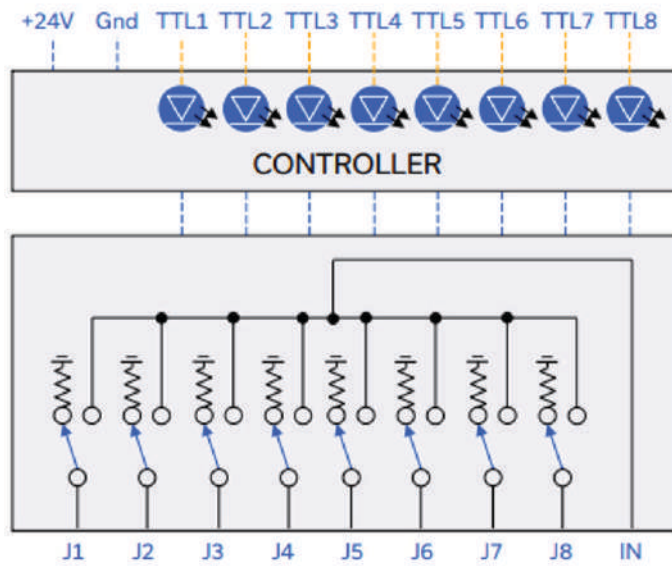

### Catalog Models

Switch Type	Switch Type	Frequency	Insertion Loss (Typ)	Isolation (Typ)	Power Rating (Cold Switching)
ZK-MSP8TA-12	SP8T	DC-12 GHz	0.4 dB	90 dB	20W
ZK-MSP6TA-12	SP6T	DC-12 GHz	0.25 dB	90 dB	20W
ZK-MSP4TA-18	SP4T	DC-18 GHz	0.5 dB	80 dB	20W
ZK-MSP2TA-18	SPDT	DC-18 GHz	0.3 dB	80 dB	20W

# Modular Switch Systems

## Overview

Mini-Circuits' modular switch systems offer flexibility, customizable functionality and fast turnaround for automated test setups. Choose one of our standard benchtop or rack-mount chassis structures and configure your system with our industry-leading range of rugged and high-performance mechanical switches. Mini-Circuits' smart modular controller provides a single interface to your system, with complete software and applications support.

## Key Benefits

- Built to order with fast turnaround
- Easy to Reconfigure Designs
- Reliable SP8T Mechanical Switch operating upto 40 GHz.
- Configure your system online for a free quote!

## Configure Your System Online

Visit our website to visualize your modular switch system in a few easy steps, then submit your configuration and online to receive a full quote and specification:

- RCM series compact benchtop housing [minicircuits.com/WebStore/rcm](http://minicircuits.com/WebStore/rcm)
- ZTM series 3U rack chassis [minicircuits.com/WebStore/ztm](http://minicircuits.com/WebStore/ztm)
- ZTM2 series 5U rack chassis [minicircuits.com/WebStore/ztm2](http://minicircuits.com/WebStore/ztm2)

## Configure and Quote

Populate each window of your test system by selecting from the 12 drop-down menus

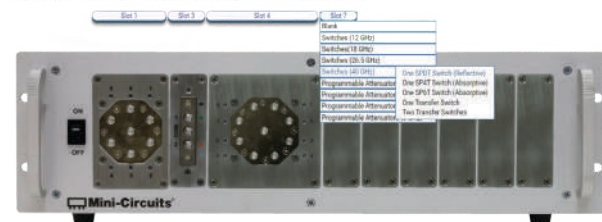

## Popular Benchtop Configurations (RCM-Series)

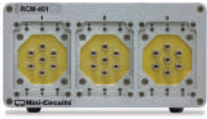

**RCM-401**  
3 x SP6T (40 GHz)

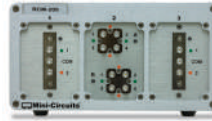

**RCM-205**  
2 x SPDT + 2 x DPDT (18 GHz)

## Popular 3U Rack-Mounted Configurations (ZTM-Series)

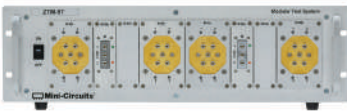

**ZTM-97**  
4 x SP4T (40 GHz)  
2 x SPDT (40 GHz)



**ZTM-6SP6T-26**  
6 x SP6T (26.5 GHz)

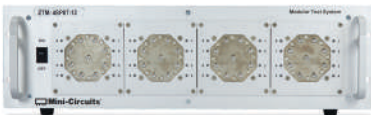

**ZTM-4SP8T-12**  
4 x SP8T (12 GHz)



**ZTM-93**  
8 x SPDT (18 GHz)  
2 x SP6T (12 GHz)

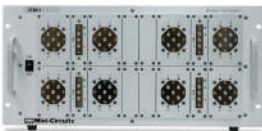

**ZTM2-1**  
8 x SP4T (18 GHz)  
4 x SPDT (18 GHz)

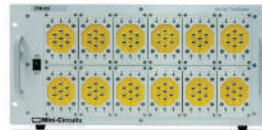

**ZTM-203**  
12 x SP6T (40 GHz)

# Mechanical Switch Arrays

## Overview

Mini-Circuits' purpose-built mechanical switch array racks can be configured according to your exact specifications. Our catalog includes a wide range of standard switch configurations that may solve your problem without the need for development time, but if you don't see a configuration that works for you, get in touch and our applications engineering team will work with you to develop the right solution.

## Key Benefits

- Wide selection of switches from SPDT to SP8T
- Options up to 50 GHz
- Rugged 19" rack-mount chassis
- USB and Ethernet control options

## Featured Systems

### ZT-375-TTL

- 5 x SP4T + 5 x SPDT mechanical switch rack
- DC-18 GHz, absorptive switches
- TTL control
- LED switch state indicators
- 3U rack chassis with integrated power supply



### ZT-16SPDT-A18

- 16 x SPDT mechanical switches
- DC to 18 GHz
- Low profile, 2U height rack chassis
- LED switch state indicators



### ZT-2SP16T-18

- 2 x SPDT + 4 x SP8T mechanical switches
- DC to 18 GHz
- Easily configured into 2 x SP16T switch using Mini-Circuits' 141 series cables
- Low profile, 2U height rack chassis
- LED switch state indicators



## Electromechanical Switch Systems – Featured Configurations

Model Number	Switch Count					Application	Frequency	Rack Height	Insertion Loss (dB)		
	DPDT	SPDT	SP4T	SP6T	SP8T				Type	Panel	
ZT-12SP6T-12R				12		Switch Rack	DC - 12 GHz	4U	SMA	Rear	
ZT-297					9	Switch Rack		4U	SMA	Front	
ZT-311		4		8		4 x SP12T Switch		4U	SMA	Rear	
ZTM2-12SP6T-12				12		Switch Rack		5U	SMA	Front	
ZTM2-8SP8T-12					8	Switch Rack		5U	SMA	Front	
ZTM-4SP8T-12					4	Switch Rack		3U	SMA	Front	
ZTM-6SP6T-12				6		Switch Rack		3U	SMA	Front	
ZT-SP36T-12A						SP36T Switch		4U	SMA	Front	
ZT-166		1	10			SP32T Switch	DC - 18 GHz	4U	SMA	Front	
ZT-169		4	10			4 x SP8T & 2 x SPDT		4U	SMA	Front	
ZT-16SPDT-A18		16				Switch Rack		2U	SMA	Front	
ZT-2SP16T-18		2			4	2 x SP16T Switch		2U	SMA	Front	
ZT-310	32					Switch Rack		5U	SMA	Front & Rear	
ZT-315			1*		5	SP40T Switch		3U	SMA	Front	
ZT-317		3				Switch Rack		1U	N-type	Rear	
ZT-375-TTL		5	5			Switch Rack		3U	SMA	Front	
ZTM2-12SP4T-18			12			Switch Rack	5U	SMA	Front		
ZTM2-24SPDT-18		24				Switch Rack	5U	SMA	Front		
ZTRC-4SPDT-A18		4				Switch Rack	1U	SMA	Front		
ZTRC-8SPDT-A18		8				Switch Rack	2U	SMA	Front		
ZTM-12MTS-26	12					Switch Rack	DC - 26.5 GHz	3U	SMA	Front	
ZTM2-8SP8T-26					8	Switch Rack		5U	SMA	Front	
ZTM-4SP8T-26					4	Switch Rack		3U	SMA	Front	
ZTM-6SP6T-26				6		Switch Rack		3U	SMA	Front	
ZTRC-4SPDT-A26		4				Switch Rack		1U	SMA	Front	
ZTRC-8SPDT-A26		8				Switch Rack		2U	SMA	Front	
ZT-14SP6T-40				14		2 x SP36T Switch		DC - 40 GHz	6U	2.92 mm	Front

# Solid State Switches

## Overview

Mini-Circuits' solid-state switch modules are ideal for applications requiring fast switching times and bullet-proof reliability. Options from SPDT to SP16T are available from stock, with some models operating up to 67 GHz.

Our solid-state design approach achieves superior isolation performance, combining some of the benefits typically reserved to mechanical switches with the speed and longer life of semiconductor-based designs. Ideal for sensitive test applications where signal selectivity is critical!

## Key Benefits

- Ultra-high reliability with long switching life
- Switch transition time as fast as 5 ns
- Daisy-chain configuration simplifies control systems

## Simplify Your Control System

The USB interface with full software support makes integrating switches into computer-controlled test systems a simple case of "plug and play." No need to spend time developing custom micro-controller implementations and software drivers.

TTL, SPI and I2C control options are also available on specific models where direct logic control interfaces are preferred.



## Daisy Chain Control of Multiple Switches

The additional serial control ports on selected models support Mini-Circuits' daisy-chain control feature with "dynamic addressing." This simplifies control systems by allowing multiple switches to be combined into a master-slave chain. Simply connect, then power on and the whole chain of compatible switches can be controlled independently through a single USB connection and software interface.



## Standard Models

Model Name	Switch Type	Low (MHz)	High (GHz)	Switch Count	Termination	Insertion Loss	Isolation	Transition Time	Input Power	Control Interfaces
U2C-1SP2T-63VH	SP2T	10	6	1	Absorptive	4.0 dB	110 dB	700 ns	36 dBm	USB + I <sup>2</sup> C + SPI
USB-SP4T-63	SP4T	1		1	Absorptive	1.0 dB	50 dB	3 μs	27 dBm	USB
USB-2SP2T-DCH	SP2T	DC	8	2	Absorptive	1.4 dB	50 dB	10 μs	35 dBm	USB + Daisy-Chain
USB-1SP16T-83H	SP16T	1		1	Absorptive	7.5 dB	100 dB	5 μs	30 dBm	USB + TTL + Daisy-Chain
USB-4SP2T-852H	SP2T	10	8.5	4	Absorptive	2.0 dB	80 dB	250 ns	30 dBm	USB + Daisy-Chain
U2C-1SP4T-852H	SP4T	2		1	Absorptive	3.7 dB	80 dB	250 ns	30 dBm	USB + I <sup>2</sup> C
USB-2SP4T-852H		10		2	Absorptive	2.5 dB	85 dB	5 μs	30 dBm	USB + Daisy-Chain
USB-1SP8T-852H	SP8T	10		1	Absorptive	4.0 dB	80 dB	250 ns	30 dBm	USB + Daisy-Chain
USB-1SP2T-183	SP2T	100	18	1	Absorptive	2.0 dB	65 dB	50 ns	25 dBm	USB + Daisy-Chain
TTL-1SP4T-183	SP4T			1	Absorptive	4.0 dB	60 dB	50 ns	30 dBm	TTL
USB-1SP4T-183				1	Absorptive	4.0 dB	65 dB	20 ns	25 dBm	USB + Daisy-Chain
TTL-1SP8T-183	SP8T			1	Absorptive	5.7 dB	60 dB	50 ns	30 dBm	TTL
USB-1SP8T-183		1	Absorptive	5.7 dB	60 dB	25 ns	24 dBm	USB + Daisy-Chain		
USB-1SP2T-34	SP2T	100	30	1	Absorptive	2.8 dB	60 dB	5 ns	24 dBm	USB + Daisy-Chain
USB-1SP4T-34	SP4T			1	Absorptive	4.5 dB	60 dB	10 ns	24 dBm	USB + Daisy-Chain
USB-1SP8T-34	SP8T			1	Absorptive	5.0 dB	80 dB	25 ns	24 dBm	USB + Daisy-Chain
USB-1SP2T-A44	SP2T	100	43.5	1	Absorptive	3.5 dB	50 dB	10 ns	24 dBm	USB + Daisy-Chain
eSB-1SP2T-A673	SP2T	100	67	1	Absorptive	4.0 dB	45 dB	600 ns	24 dBm	USB + Daisy-Chain
RCS-1SP2T-A673				1	Absorptive	4.5 dB	45 dB	600 ns	24 dBm	LAN + USB + Daisy-Chain
USB-1SP2T-673				1	Reflective	4.0 dB	35 dB	5 μs	27 dBm	USB + Daisy-Chain
eSB-1SP4T-A673				SP4T	1	Absorptive	6.0 dB	45 dB	600 ns	24 dBm
RCS-1SP4T-A673	1	Absorptive	6.5 dB		45 dB	600 ns	24 dBm	LAN + USB + Daisy-Chain		

## Key Benefits

### eSB & RCS Series Switches operating frequency upto 67 GHz

- Operation to 67 GHz with 1.85 mm connectors
- Ultra-high reliability with low loss and long switching life
- Ethernet & USB control versions
- Daisy-chain control interface

### TTL Controlled Solid-State Switches

- PIN diode solid-state switches, 100 MHz to 18 GHz
- Low insertion loss
- High input power: +30 dBm for hot & cold switching & terminations
- TTL control with very fast switching, 100ns typical switching time to settled time.
- Application in 5G / 6G testing , Radar testing

### eSB Series

- USB + daisy-chain
- Ideal for benchtop applications
- LED state indicators



# Solid State Switch Racks

## Overview

Leverage Mini-Circuits' full range of high-performance solid-state switches to simplify your production test racks, integrating your required switch configuration within a convenient rack-mountable chassis with a single Ethernet / USB control interface.

Popular configurations are available from our catalog without special development effort, and custom systems are available on request. Our novel daisy-chain interface can also be included, enabling multiple switch racks to be stacked so that all control is managed through a single software interface.

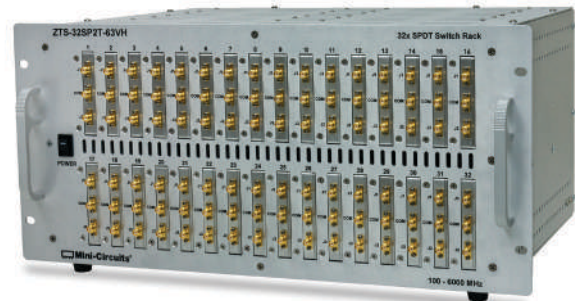

## Standard Models

Model Number	Switch Type	Frequency	Switch Count	Rack Height	Connectors	Panel	Control
ZT-24SP2T-63VH	SPDT	600 - 6000 MHz	24	4U	N-type	Front & Rear	USB & Ethernet
ZTS-32SP2T-63VH		100 - 6000 MHz	32	5U	SMA	Front	USB & Ethernet
ZTS-16SP4T-63H	SP4T	10 - 6000 MHz	16	2U	SMA	Front	USB & Ethernet Daisy-Chain
ZTS-6SP8T-63R	SP8T	10 - 6000 MHz	6	3U	SMA	Rear	USB & Ethernet
ZTS-8SP8T-63		10 - 6000 MHz	8	4U	SMA	Front	USB & Ethernet
ZT-320	SP16T	1 - 6000 MHz	30	3U	SMA	Rear	USB & Ethernet & Daisy-Chain
ZTS-1SP16T-83R		1 - 8000 MHz	1	1U	SMA	Rear	USB & Ethernet
ZTS-1SP80T-63H	SP80T	10 - 6000 MHz	1	2U	SMA	Front & Rear	USB & Ethernet & Daisy-Chain

## Featured Systems

### ZTS-1SP80T-63H

- Single SP80T switch, 10-6000 MHz
- N-type input & SMA outputs
- Control via Ethernet & USB
- Daisy-chain stacking interface



### ZTS-16SP4T-63H

- 16 x SP4T switches, 10-6000 MHz
- SMA connectors on front panel
- Control via Ethernet & USB
- Daisy-chain stacking interface



### ZTS-6SP8T-63R

- 6 x SP8T switches, 10-6000 MHz
- All SMA connectors on rear panel
- High isolation
- Control via Ethernet & USB



## Simplify your switch rack control system using Mini-Circuits' novel daisy-chain stacking system:

1. Connect together multiple solid-state switch racks using the serial In and Out connectors
2. Automatically create a single "stacked" system, by powering on each rack
3. Connect a single USB or Ethernet connection to the "Master" unit for control
4. Easily manage and control every switch in the stack through a single software GUI or API

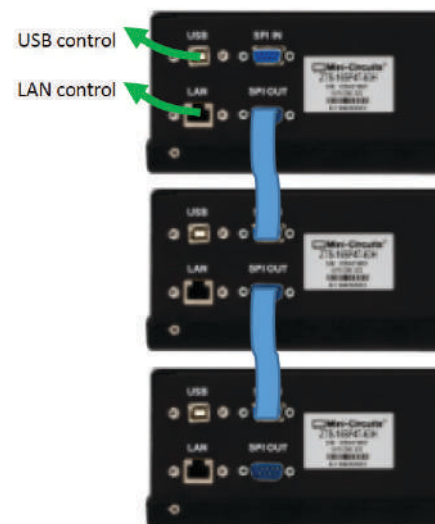

# Switch Matrices

## Overview

Our integrated switch matrices provide reliable and repeatable signal routing for any application. Blocking, non-blocking and full fan-out switch matrices are available using many combinations of mechanical and solid-state switch technologies to meet your unique system requirements.

## Key Benefits

- Blocking, non-blocking and full-fanout configurations
- Ideal for managing complex signal traffic
- Combinations of mechanical and solid state switches for optimal performance



## Switch Matrix Configurations: Comparison Matrix

Feature	Blocking	Non-Blocking	Full Fan-Out
Each path can connect a single input to a single output	Yes	Yes	Yes
Each path can connect a single input to multiple outputs	No	Yes	Yes
Each path can connect multiple inputs to multiple outputs	No	No	Yes
Insertion Loss	Lowest	Medium	Highest
Variable Path Loss	No	No	Yes
Power Rating	Highest	Medium	Medium

# Non-Blocking Switch Matrices

## Fan-Out Operation:

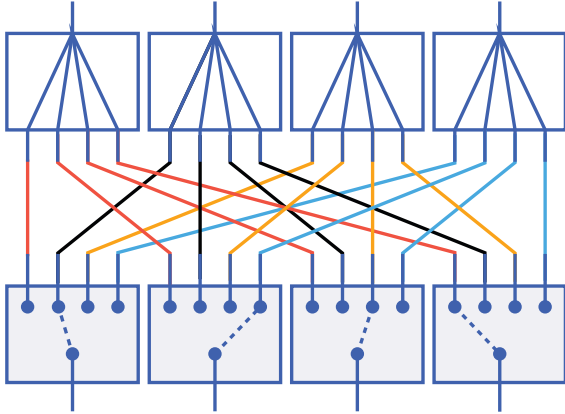

### Construction

- Splitters on inputs, switches on outputs

### Switch Path Combinations

- One to many
- Each path connects a single input to any combination of outputs
- The input port can be used by multiple active paths
- The output ports can't be used by any other active paths

### Advantages

- Multiple devices on the outputs can be driven by the same input

### Common Applications:

- Receiver Testing

## Fan-In Operation:

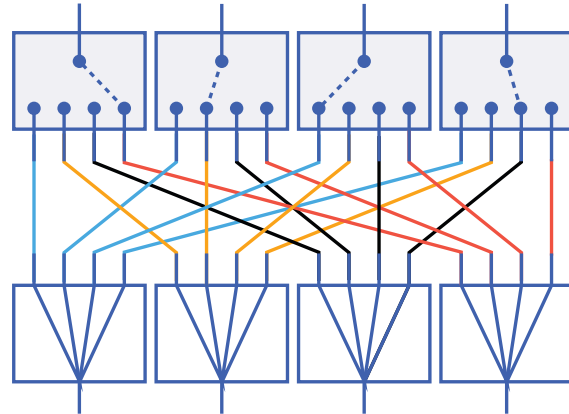

### Construction

- Switches on inputs, splitters on outputs

### Switch Path Combinations

- Many to one
- Each path connects any combination of inputs to a single output
- The input ports can't be used by any other active paths
- The output port can be used by multiple active paths

### Advantages

- Multiple devices on the inputs can feed the same output

### Common Applications:

- Transmitter testing

# Non-Blocking Switch Matrices Continued

## Standard Configurations

Model Name	F Low (MHz)	F High (GHz)	Configuration	Impedance	Height	Connectors	Control
ZT-4X4NB	400	6	4 x 4	50	3U	SMA	USB; LAN
ZT-10X6NB			10 x 6	50	5U	N-type	USB; LAN; Touchscreen
ZT-20X6NB			20 x 6	50	5U	SMA	USB; LAN; Touchscreen
ZT-10X30NB	600		10 x 30	50	4U	SMA	USB; LAN; Daisy-Chain
ZT-80X30NB			80 x 30	50	38U	SMA	USB; LAN
ZT-8X8NB			8 x 8	50	3U		USB; LAN; Daisy-Chain

### Close-Up: ZT-10X30NB

High-performance 10 x 30 non-blocking switch matrix

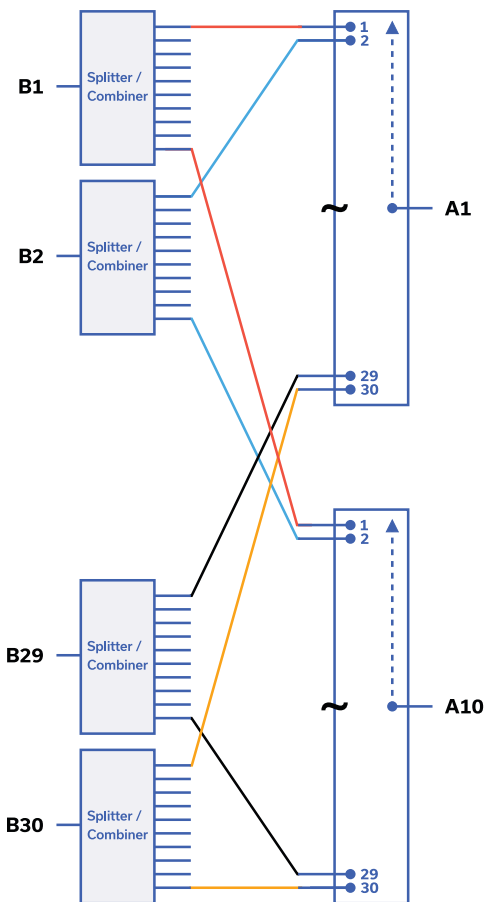

- Bi-directional operation
- Any of the 10 "A" ports can connect to any combination of the 30 "B" ports
- Ideally suited to cellular test systems
- Allows 30 separate test stations to access any of 10 base-station channels, without affecting any other test stations.

Parameter	Conditions	Min	Typ	Max	Units
Frequency	-	600	-	6000	MHz
Path Loss	600-3000 MHz	-	23	25	dB
	3000-6000 MHz	-	26	30	
Isolation-Inative Paths	600-3000 MHz	60	80	-	dB
	3000-6000 MHz	55	70	-	
Return Loss	-	-	None	-	dB

# Blocking Switch Matrices

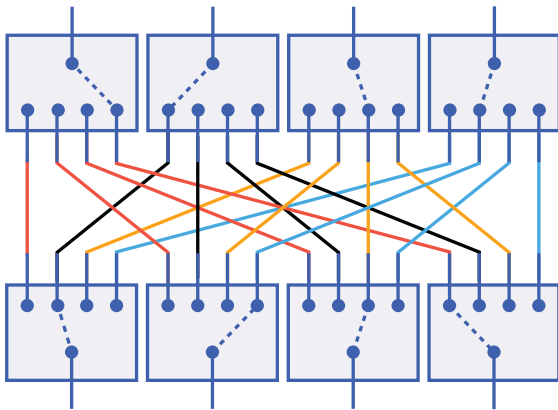

## Construction

- Switches on inputs and outputs

## Switch Path Combinations

- One-to-one
- Each path connects a single input to a single output
- The input and output can't be used by any other active paths
- Bi-directional operation

## Advantages

- Broadest frequency range options
- Lowest insertion loss

## Common Applications:

- Multi-channel / MIMO / LTE radio testing
- Satcom signal routing
- Component characterisation / qualification testing
- VNA extension

## Blocking Switch Matrices Continued

### Blocking Standard Configurations

Model Name	F Low (MHz)	F High (GHz)	Configuration	Impedance	Height	Connectors	Control		
ZTVX-10-75-N	5	2.5	2 x 10	75	4U	N-type	USB; LAN		
ZTVX-12-75-N			2 x 12	75	4U	N-type	USB; LAN		
ZTVX-16-75-N			2 x 16	75	4U	N-type	USB; LAN		
ZTVX-8-75-N			2 x 8	75	3U	N-type	USB; LAN		
ZTVS-16-06-S	10	6	2 x 16	50	3U	SMA	USB; LAN; Daisy-Chain		
ZT-8X8B			8 x 8	50	3U	SMA	USB; LAN; Daisy-Chain		
ZT-12X12B			12 x 12	50	4U	SMA	USB; LAN; Daisy-Chain		
ZT-16X48B			16 x 48	50	14U	SMA	USB; LAN		
ZT-24X48B			24 x 48	50	48U	SMA	USB; LAN		
ZT-24X8B			24 x 8	50	5U	SMA	USB; LAN; Daisy-Chain		
ZTVX-10-12-S	DC	12	2 x 10	50	2U	SMA	USB; LAN		
ZTVX-12-12-S			2 x 12	50	2U	SMA	USB; LAN		
ZTVX-16-12-S			2 x 16	50	2U	SMA	USB; LAN		
ZTVX-32-12-S			2 x 32	50	4U	SMA	USB; LAN		
ZTVX-8-12-S			2 x 8	50	2U	SMA	USB; LAN		
ZT-6X3B			6 x 3	50	3U	SMA	USB; LAN		
ZT-175			6 x 8	50	4U	SMA	USB; LAN		
ZTVX-10-18-S			DC	18	2 x 10	50	2U	SMA	USB; LAN
ZTVX-12-18-S					2 x 12	50	2U	SMA	USB; LAN
ZTVX-16-18-S					2 x 16	50	2U	SMA	USB; LAN
ZTVX-8-18-S	2 x 8	50			2U	SMA	USB; LAN		
ZT-4X4B-18-S	4 x 4	50			3U	SMA	USB; LAN		
ZT-8X8B-1835	8 x 8	50			4U	SMA	USB; LAN		
ZT-4X12B-26-S	DC	26.5			4 x 12	50	4U	3.5 mm	USB; LAN

## Close-Up: ZTVX-16-18-S

### Broadband 2x16 Blocking Switch Matrix

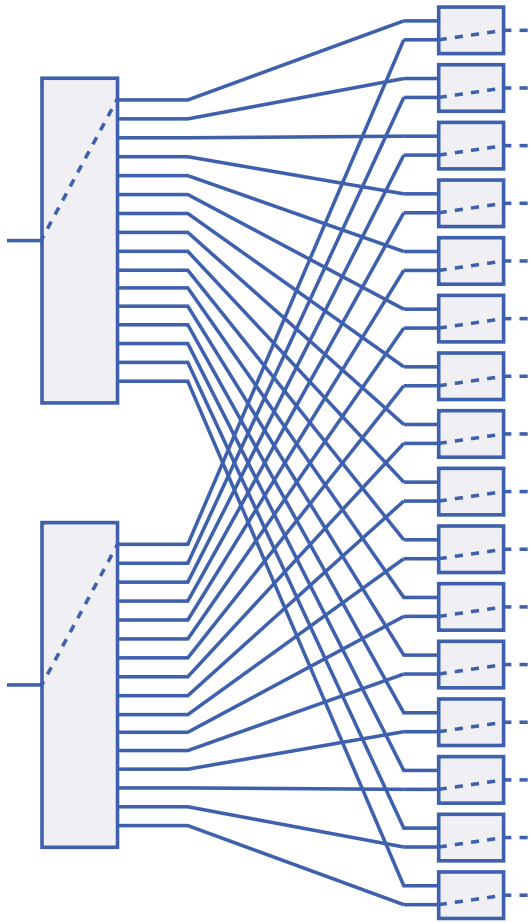

Broadband 2 x 16 blocking switch matrix, operating up to 18 GHz. The low loss, high isolation and blocking configuration with 2 active paths lends itself to use as a VNA extender:

- Extension of a 2-port VNA to multiple DUT
- Characterisation of multi-port devices
- Testing of MIMO systems with high channel counts
- 2 x 8, 2 x 10, 2 x 12, 2 x 16 and 2 x 32 configurations available

Parameter	Conditions	Min	Typ	Max	Units
Frequency	-	DC	-	18	GHz
Path Loss	DC - 8 GHz	-	1.2	-	dB
	8-18 GHz	-	2.0	-	
Isolation- Inactive Paths	DC - 8 GHz	-	100	-	dB
	8-18 GHz	-	90	-	
Return Loss	-	-	15	-	dB
Input Power	Per port	-	-	30	dBm

# Fully Non-Blocking / Full Fan-Out Attenuator Matrices

## Overview

“Full fan-out” or “fully non-blocking” systems use a combination of programmable attenuators and splitter / combiners to provide a completely flexible set of paths between a group of input and output ports. Similar to a switch matrix except any individual path can be “on” (0 dB attenuation), or “off” (max attenuation), or any attenuation value in-between. In addition, all inputs can connect simultaneously to all outputs, and all paths are bi-directional. This completely flexible set of characteristics provides a powerful matrix for test environments.

## Key Benefits

- Many-to-many configuration—all inputs can connect to all outputs simultaneously
- Programmable attenuators on every channel to vary path loss
- Ideal for transceiver / handover test systems

## Construction

- Splitter/combiners on inputs and outputs
- Programmable attenuators used for path “switching” and signal level control

## Switch Path Combinations

- Many to many
- Each path connects any combination of inputs to any combination of outputs
- All input and output ports can be used by multiple active paths

## Advantages

- Completely flexible path combinations
- Programmable attenuators allow precise signal level, rather than just on or off
- Multiple devices on the inputs can feed the same output
- Multiple devices on the outputs can be driven by the same input

## Common Applications

- Transmitter & receiver testing
- Cellular handover testing
- Massive MIMO

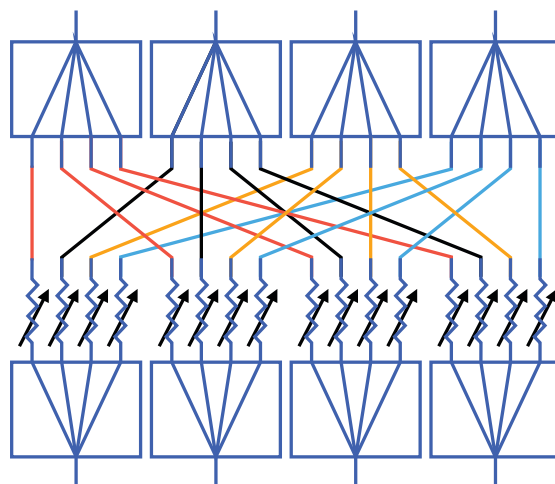

## Fully Non-Blocking Standard Configurations

Model Name	Frequency	Configuration	Attenuation	Height	Connectors	Control
ZT-24RFX8		24 x 8	0-63 dB	5U	SMA	USB; LAN; Daisy-Chain
ZT-16RFX8	500-6000 MHz	16 x 8	0-63 dB	5U	SMA	USB; LAN; Daisy-Chain
ZT-8RFX8		8 x 8	0-63 dB	3U	SMA	USB; LAN; Daisy-Chain
ZT-8RFX8-6E	500-7200 MHz	8 x 8	0-63 dB	3U	SMA	USB; LAN; Daisy-Chain

### Close-Up: ZT-8RFX8-6E

8x8 Full Fan-Out / Fully Non-Blocking Matrix

- Operation from 500 MHz to 7.2 GHz
- USB & Ethernet control



### Path Loss at Attenuation Steps:

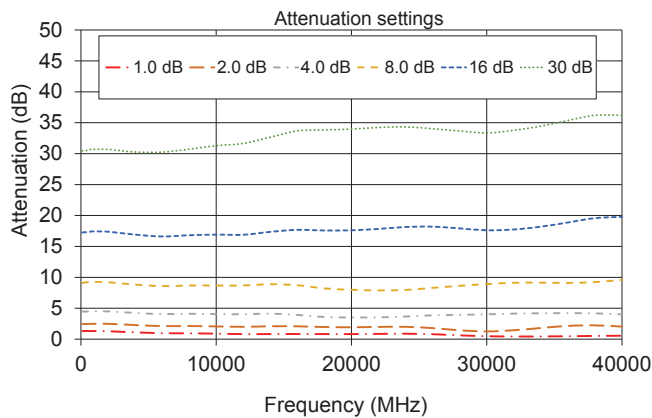

### Functional Schematic:

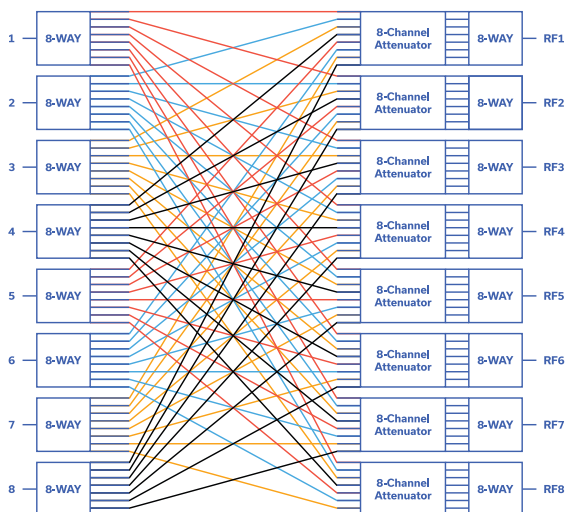

Parameter	Conditions	Min	Typ	Max	Units
Frequency	-	500	-	7200	MHz
Path Loss	500 - 3000 MHz	-	23	28	dB
	3000 - 6000 MHz	-	28	34	
	6000 - 7200 MHz	-	30	34	
Return Loss	500 - 3000 MHz	-	18	-	dB
	3000 - 7200 MHz	-	13	-	
Attenuation Range	Per path, 0.25 dB steps	0	-	63	
Isolation (between adjacent ports @ 0 dB)	500 - 3000 MHz	45	52	-	dB
	3000 - 7200 MHz	48	57	-	
Isolation (in <math>\leftrightarrow</math> out @ 63 dB)	500 - 3000 MHz	-	83	-	dB
	3000 - 7200 MHz	-	90	-	
Input Power	-	-	-	+30	dBm

# Signal Conditioning & Attenuation

Our programmable attenuator product line provides versatile solutions for automating signal level control, simulating the effects of signal fading and a number of other useful functions. Our programmable attenuators offer outstanding accuracy, even at the highest attenuation settings and wide frequency ranges up to 67 GHz. These devices may be used individually or integrated into multi-channel systems for higher-volume setups.

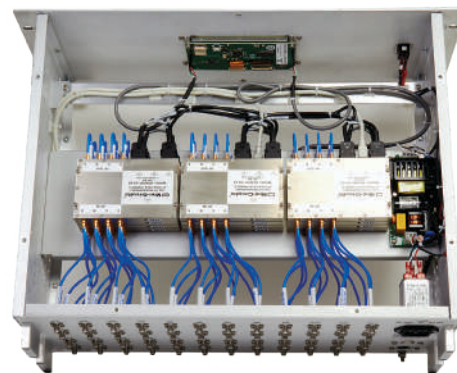

## Programmable Attenuators Off the Shelf

### Overview

Mini-Circuits' compact programmable attenuators are designed with wide attenuation ranges and fine step sizes, for precise signal level control. Coupled with our standard USB & Ethernet control interfaces, these devices are easily integrated into any test system for simulation of transmission loss, signal fading, cross talk and power level calibration.

### Key Benefits

- Frequency range up to 67 GHz
- Attenuation range up to 120 dB
- Step size as small as 0.05 dB
- Automation via Ethernet or USB



### Common Applications

- Transmission loss simulation
- LTE / 4G / 5G network infrastructure
- IoT / Bluetooth / Zigbee / Wi-Fi 6E
- Power level cycling

## Catalog Models

Model Name	F Low (MHz)	F High (GHz)	"Attenuation Range (dB)"	"Attenuation Steps (dB)"	Input Power	Control
RCDAT-3000-63W2	50	3	0 - 63	1	+33 dBm	USB & LAN
RUDAT-4000-120	1	4	0 - 120	0.25	+20 dBm	USB & RS232
RCDAT-4000-120			0 - 120	0.25	+20 dBm	USB & LAN
RUDAT-6000-30	1	6	0 - 30	0.25	+20 dBm	USB & RS232
RUDAT-6000-60			0 - 60	0.25	+20 dBm	USB & RS233
RUDAT-6000-90			0 - 90	0.25	+20 dBm	USB & RS234
RUDAT-6000-110			0 - 110	0.25	+20 dBm	USB & RS235
RCDAT-6000-30			0 - 30	0.25	+20 dBm	USB & LAN
RCDAT-6000-60			0 - 60	0.25	+20 dBm	USB & LAN
RCDAT-6000-90			0 - 90	0.25	+20 dBm	USB & LAN
RCDAT-6000-110	0 - 110	0.25	+20 dBm	USB & LAN		
RCDAT-6G-120H	200	8	0 - 120	0.05	+23 dBm	USB & LAN
RCDAT-8000-30	1		0 - 30	0.25	+28 dBm	USB & LAN
RCDAT-8000-60			0 - 60	0.25	+28 dBm	USB & LAN
RCDAT-8000-90			0 - 90	0.25	+28 dBm	USB & LAN
RCDAT-8G-120H	200	0 - 120	0.05	+23 dBm	"USB & LAN & Daisy-Chain"	
RUDAT-13G-60	10	13	0 - 60	0.5	+23 dBm	USB & SPI & RS232
RUDAT-13G-90			0 - 90	0.5	+23 dBm	USB & SPI & RS233
RCDAT-18G-63	100	18	0 - 63	0.25	+24 dBm	"USB & LAN & Daisy-Chain & TTL"
RCDAT-30G-30	100	30	0 - 30	0.5	+24 dBm	"USB & LAN & Daisy-Chain"
RCDAT-44G-30	100	43.5	0 - 30	0.5	+22 dBm	"USB & LAN & Daisy-Chain"
RCDAT-44G-63			0 - 63	0.5	+22 dBm	"USB & LAN & Daisy-Chain"
RCDAT-50G-30	100	50	0 - 30	0.5	+24 dBm	"USB & LAN & Daisy-Chain"
eDAT-67G-30	10	67	0 - 31.5	0.5	+26 dBm	USB & Daisy-Chain
eDAT-67G-60			0 - 63	0.5	+26 dBm	USB & Daisy-Chain

# Programmable Attenuators Off the Shelf Continued

## Close-Up: RCDAT-18G-63

### Key Features:

- High Frequency, 18 GHz
- Fine attenuation resolution, 0.25 dB
- Fast switching speed
- USB, Ethernet, RS232 and TTL control

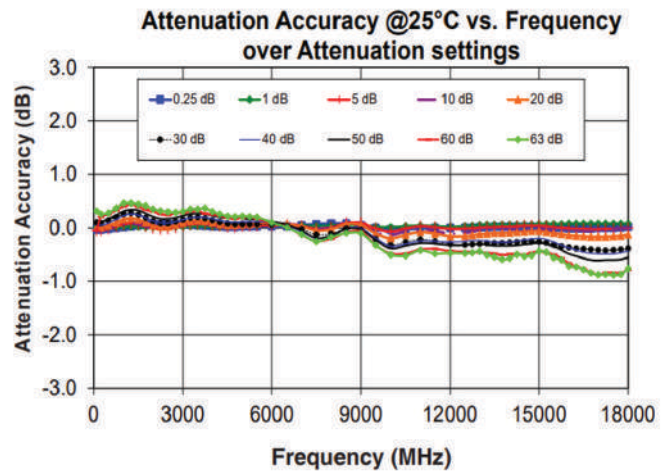

## Close-Up: eDAT-67G-60

### Key Features:

- Super wide bandwidth, solid-state design
- High power handling (+26 dBm CW)
- Daisy-chain control of up to 25 units
- USB control and automation
- Display of attenuation state on unit

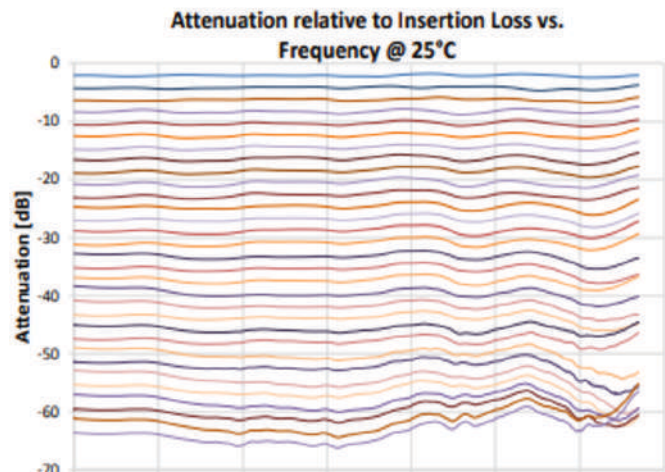

# Multi-Channel Attenuators Off the Shelf

Compact Modules

## Overview

Mini-Circuits' RC4DAT (4-channel) and RC8DAT (8-channel) series programmable attenuators are the perfect solution for multi-channel and multi-device test systems.

Each model combines 4 or 8 independently controllable attenuation channels in one compact package, with high isolation of cross-talk between channels. All channels are controlled through a single interface.

## Key Benefits

- Multiple independently controlled channels in a single, compact module
- Frequency range up to 8 GHz
- Attenuation range up to 120 dB
- Step size as small as 0.05 dB

## Common Applications

- Cellular handover testing
- MIMO verification
- Mesh network testing

## Featured Product: RC8DAT-8G-95PE

### Key Features:

- Eight independently programmable channels
- Over 100 dB Isolation between channels
- Repeatable 0-95 dB attenuation range
- SSH Secure Ethernet communication
- Power over Ethernet (PoE) per IEEE 802.3af

### Applications:

- Wi-Fi 6E MIMO development
- LTE / 5G / IoT / Bluetooth / Zigbee
- Cellular handover testing
- C-band radar / satcom testing
- Automated signal sweeping / fading



## Multi-Channel Attenuators — Catalog Models

Model Number	Freq. Low (MHz)	Freq. High (MHz)	Channels	Attenuation	Step Size	Input Power	Control
RC4DAT-6G-30			4	0 - 30 dB	0.25 dB	+23 dBm	USB & LAN
RC4DAT-6G-60	1	6	4	0 - 63 dB	0.25 dB	+23 dBm	USB & LAN
RC4DAT-6G-95			4	0 - 95 dB	0.25 dB	+23 dBm	USB & LAN
RC4DAT-8G-95	1		4	0 - 95 dB	0.25 dB	+28 dBm	USB & LAN
RC4DAT-8G-95PE			4	0 - 95 dB	0.25 dB	+28 dBm	USB & LAN (PoE)
RC4DAT-8G-120H	100	8	4	0 - 120 dB	0.05 dB	+23 dBm	USB & LAN & Daisy-Chain
RC8DAT-8G-95	1		8	0 - 95 dB	0.25 dB	+28 dBm	USB & LAN
RC8DAT-8G-95PE			8	0 - 95 dB	0.25 dB	+28 dBm	USB & LAN (PoE)

# Multi-Channel Attenuators Continued

## Rack-Mount Systems

### Overview

Our rack-mounted TDAT series multi-channel attenuator systems cater to test systems with many channels running in parallel. Mini-Circuits' high performance attenuators are used with typically 100 dB isolation between channels. Address each channel independently or configure automated sweep, hop and fading sequences across the complete system. Mini-Circuits has designs available for a wide range of requirements, with custom configurations available on request up to 43.5 GHz and beyond.

### Key Benefits

- 19" rack mount chassis
- Up to 48 channels per system
- Daisy chain multiple systems for more channels from a single interface

### Daisy Chain Control Stacking

Multiple units can be configured into a single system using Mini-Circuits' daisy-chain stacking interface, allowing 100s of attenuator channels to be controlled through a single USB or Ethernet connection.

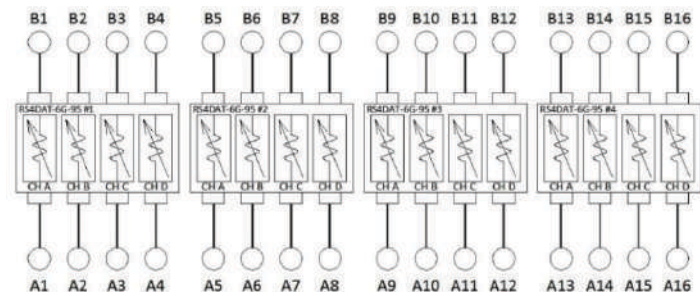
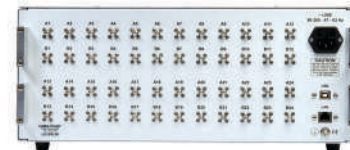

## Rack Mount Attenuation Systems – Standard Configurations

Model Name	Freq(MHz)		Attenuation	Channels	Rack	Connectors	Panel	Control			
	Low	High									
ZTDAT-8-6G30S	1	6	0 - 30 dB	8	1U	SMA	Front & Rear	USB & LAN & Daisy-Chain			
ZTDAT-12-6G30S				12	1U	SMA	Front & Rear	USB & LAN & Daisy-Chain			
ZTDAT-8-6G63SR			0 - 63 dB	8	1U	SMA	Rear	USB & LAN & Daisy-Chain			
ZTDAT-16-6G63S				16	1U	SMA	Front & Rear	USB & LAN & Daisy-Chain			
ZTDAT-8-6G95S			0 - 95 dB	8	8	1U	SMA	Front & Rear	USB & LAN & Daisy-Chain		
ZTDAT-8-6G95SR					8	1U	SMA	Rear	USB & LAN & Daisy-Chain		
ZTDAT-12-6G95S					12	1U	SMA	Front & Rear	USB & LAN & Daisy-Chain		
ZTDAT-12-6G95SR					12	2U	SMA	Rear	USB & LAN & Daisy-Chain		
ZTDAT-16-6G9543					16	2U	4.3-10	Front & Rear	USB & LAN & Daisy-Chain		
ZTDAT-16-6G95N					16	2U	N-Type	Front & Rear	USB & LAN & Daisy-Chain		
ZTDAT-16-6G95S					16	1U	SMA	Front & Rear	USB & LAN & Daisy-Chain		
ZTDAT-24-6G95S					24	2U	SMA	Front & Rear	USB & LAN & Daisy-Chain		
ZTDAT-8-8G95S					0 - 95 dB	8	8	1U	SMA	Front & Rear	USB & LAN & Daisy-Chain
ZT16DAT-8G95S							16	1U	SMA	Front	USB & LAN & Daisy-Chain
ZT8DAT-8G95SF	10	13	0 - 60 dB	8	1U	SMA	Front & Rear	USB & LAN & Daisy-Chain			
ZTDAT-4-13G60S				4	1U	SMA	Front	USB & LAN			
ZTDAT-8-13G60S			8	2U	SMA	Front	USB & LAN				
ZTDAT-4-13G90S			0 - 95 dB	4	1U	SMA	Front	USB & LAN			
ZTDAT-8-13G90S				8	2U	SMA	Front	USB & LAN			
ZTDAT-4-18G63S			0 - 63 dB	18	4	1U	SMA	Front	USB & LAN		
ZTDAT-8-44G63K	8	2U			2.92 mm	Front	USB & LAN				

# Targeted Solutions & Use Cases

In addition to hundreds of general-purpose test systems, Mini-Circuits has developed several solutions based on common test use cases in the market. Our solutions include multiple options for simulating real-world signal conditions in the lab environment, high-power test systems to scale up throughput for burn-in testing and more.



## Cellular Handover Test Systems

### Overview

Testing of multi-band cellular systems typically requires a test environment capable of combining and varying signals from multiple radios and interferers into the device (or devices) under test. Mini-Circuits has a range of handover test systems combining programmable attenuators and power splitters and combiners for this purpose. These configurations allow simulation of “real-world” conditions for wireless handsets, radio-heads, antenna systems, base-stations and nodes.

### Key Benefits

- Simulates distance and signal transition in a lab environment
- Independently controlled attenuation on every channel
- Expandable by connecting multiple units in daisy chain configuration

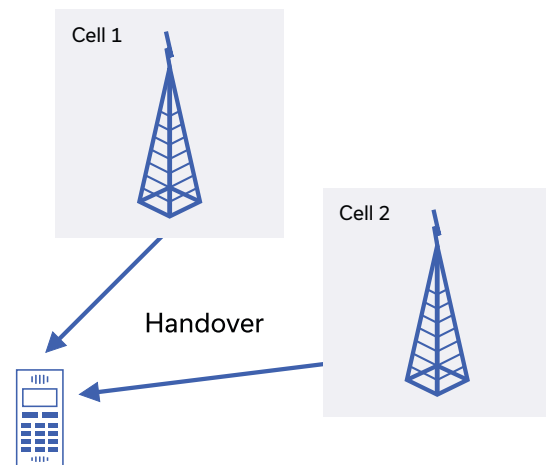

### Typical applications include:

1. Varying path loss between a wireless device and node during transmission
2. Hand-over from one node to another as a wireless device moves out of range
3. Verification of device performance in the presence of multiple radio signals and interferers

## Cellular Handover Test Standard Configurations

Model Name	Frequency	Inputs	Outputs	Attenuation	Height	Connectors	Control
ZT-279	500 - 6000 MHz	2	4	0 - 95 dB	1U	SMA	USB & Ethernet & Daisy-Chain
ZT-278	500 - 6000 MHz	4	32		3U	SMA	
ZT-217	600 - 6000 MHz	3	20		4U	N-type	
ZT-217-S	600 - 6000 MHz	3	20		4U	SMA	

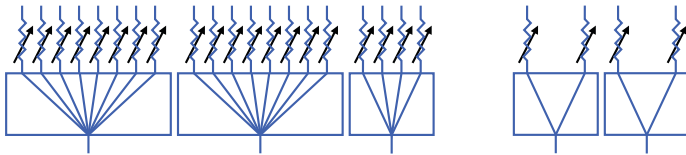

**ZT-217 and ZT-217-S**

**ZT-279**

### Close-Up: ZT-278

4-Input to 32-Output Matrix

#### Key Features:

- Independent 0-95 dB attenuation per output
- Operation from 500 MHz to 6 GHz
- USB & Ethernet control

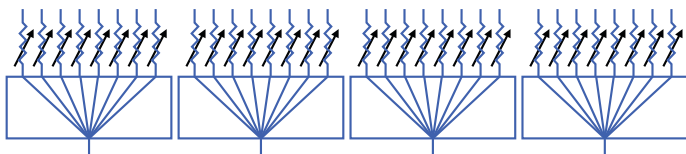

Parameter	Conditions	Min	Typ	Max	Unit
Frequency	-	500	-	6000	MHz
Insertion Loss	Attenuation = 0 dB	-	18	22	dB
Return Loss	-	-	12	-	dB
Isolation	Between outputs of the same splitter	22	35	-	dB
	Between adjacent input ports	90	100	-	
Attenuation Range	0.25 dB Steps	0	-	90	dB
	0.50 dB Steps	90	-	95	
Input Power	RF-A, RF-B, RF-C, RF-D	-	-	+30	dBm
	A1-8; B1-8; C1-8; D1-8	-	-	+23	

# Mesh Network Simulation Racks

## Overview

Mini-Circuits has developed a range of test systems for characterizing wireless mesh network devices. All external ports of the mesh are interconnected to simulate an over-the-air wireless mesh configuration. Programmable attenuators on each internal path allow the path loss to be varied independently between any pair of devices, without affecting communication between any other pair.

This configuration allows the simulation of real-world mesh characteristics within a confined lab or production environment, including:

1. Receiver sensitivity
2. Changes in range between devices
3. Performance in the presence of interfering signals
4. Ability of devices to relay signals between nodes

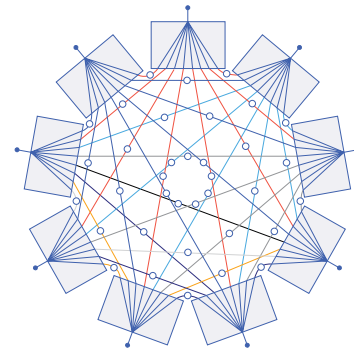

## Key Benefits

- Configurations from 3 to N ports
- Independently controlled attenuation on every path

## Common Applications

- R&D testing of wireless "smart" devices
- Bluetooth, Zigbee, Z-Wave, WiFi, IoT
- Qualification / acceptance testing of military radios
- UHF / VHF band man-pack / vehicular systems
- ISM band fire & security monitoring

## Mesh Network Test Standard Configurations

## Close-Up: ZTMN-0695C-S

### Key Features:

- 6 fully interconnected test ports (15 internal paths)
- 95 dB programmable attenuation per path
- Configure automated sweep / hop / fading sequences
- Ethernet & USB control



Parameter	Conditions	Min	Typ	Max	Unit
Frequency	-	2000	-	8000	MHz
Insertion Loss	Direct path	-	30	35	dB
	Indirect path	55	70	-	dB
Isolation	Direct path	95	110	-	dB
	Indirect path	-	-	-	-
Return Loss	-	-	17	-	dB
Attenuation Range	2000 - 7200 MHz	0	-	95	dB
	7200 - 8000 MHz	0	-	90	dB
Attenuation Steps	-	-	0.25	-	dB
Input Power	-	-	-	+25	dBm

## Close-Up: ZTMN-1695A-S

### Key Features:

- 16 fully interconnected test ports
- Single rack-mountable chassis, 5U height
- 90 dB programmable attenuation per path
- Configure automated sweep / hop / fading sequences
- Ethernet & USB control



Parameter	Conditions	Min	Typ	Max	Unit
Frequency	-	30	-	3000	MHz
Insertion Loss	30-2000 MHz	-	33	38	dB
	2000-3000 MHz	-	36	44	dB
Isolation	Direct path (30-3000 MHz)	-	110	-	dB
	Leakage path (30-3000 MHz)	-	70	-	dB
Return Loss	-	-	15	-	dB
Input Power	Per port	-	-	+25	dBm
Attenuation Range	Per path	0	-	90	dB
Attenuation Steps	0 - 90 dB Range	-	0.25	-	dB

## Custom Mesh Configurations

Custom frequency, port and connector configurations can be provided on request.

Number of Ports	Number of Paths
4	6
6	15
8	28
9	36
16	120
32	496

# High Power Test Systems

## Overview

Mini-Circuits provides all the key building blocks needed for creation of high-power RF test systems. Our off the shelf 100W saturated output power amplifiers can be combined with signal sources, distribution systems and loads to create complete integrated test systems.

## Key Benefits

- Signal sources, amplifiers and distribution systems
- Distribute signal up to 100W into multiple channels

## High Power Test Applications

- HTOL (high temperature operating life)
- General burn-in / RF stress testing
- EMC / EMI testing

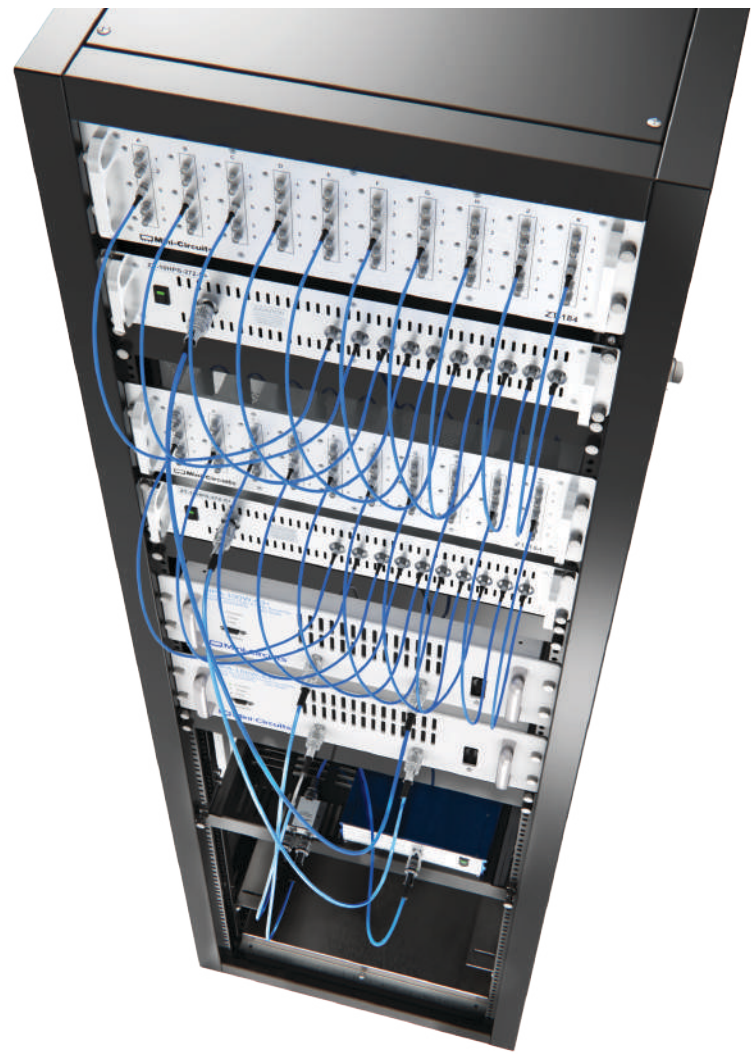

## Featured Systems

Model Name	Frequency (MHz)	Output Channels	Power per Channel (W)	Description
HTOL-700-2700-1W	700 - 2700	80	1	HTOL signal source and distribution system
HTOL-2500-6000-1W	2500 - 6000	80	1	HTOL signal source and distribution system
HTOL-700-2700-3W	700 - 2700	80	3	HTOL signal source and distribution system

## High-Power Passive Systems

### Key Benefits

- Rack-mountable splitters rated up to 100W
- High power attenuator / load boxes
- High power switch systems



### Featured Systems

Model Name	Frequency (MHz)	Power (W)	Rack Height	Description
ZT-184	500 - 6000	30	3U	10 x 4-way splitter / combiner panel
ZT-10HPS-272	700 - 2700	100	2U	10-way high power splitter
ZT-16HPS-63W-S	700 - 6000	100	2U	16-way high power splitter
ZT-20HPS-63-S	2500 - 6000	100	2U	20-way high power splitter
ZT-337	DC - 6000	100	3U	4-channel 30 dB higher power attenuator
ZT-234	1 - 3000	100	4U	High power switch / attenuator system

## High-Power Amplifiers

### Key Benefits

- Rack-mountable broadband amplifiers
- Saturated output powers up to 100W
- See p. 51 for custom amplifier configurations



### Featured Systems

Model Name	Frequency (MHz)	Gain (dB)	PSAT (W)	Rack Height
HPA-25W-272+	20 - 2700	50	25	2U
HPA-25W-63+	700 - 6000	53	25	2U
HPA-50W-63+	700 - 6000	56	50	3U
HPA-272+	700 - 2700	48	100	3U
HPA-100W-63+	2500 - 6000	58	100	3U

## Use Case: 80-Channel HTOL Test System

HTOL (high temperature operating life) is a test methodology intended to stress a device over an extended period of time, allowing calculation of a device's long-term reliability. The test is applicable to a wide range of component manufacturing applications, IC manufacturers in particular, including amplifiers, filters and transceivers.

The concept requires an RF splitter system to distribute a test signal over a large number of DUT (device under test) channels in parallel so that a statistically significant calculation of reliability can be made. A high power signal source is also required, sufficient to drive each DUT at the appropriate level whilst also overcoming the inevitable signal losses, inherent in the distribution system.

Mini-Circuits can provide all the building blocks required for HTOL testing, including a ready-made integrated system supplied in a rack cabinet. The system pictured in the block diagram and image below is HTOL-700-2700-1W, a complete HTOL test setup capable of driving 80 parallel DUT at 1W each in the 700-2700 MHz band.

### The component modules are:

- **SSG-6000RC** signal source
  - 25 to 6000 MHz CW signal generation with up to +14 dBm output
- **ZAPD-2-272+** power splitter
  - Wideband 2-way splitter, routing the signal source into 2 parallel paths
- 2 x **HPA-272+** high power amplifiers
  - Pair of 700 to 2700 MHz power amplifiers, each with 100 W saturated output power
- 2 x **ZT-10HPS-272+** high power splitters
  - Pair of 10-way splitters covering 700 to 2700 MHz with 100W input power rating
- 2 x **ZT-184** medium power splitter matrix
  - Each ZT-184 houses 10 x 4-way splitter/combiners covering 380 to 4600 MHz, with an input power rating of 30W

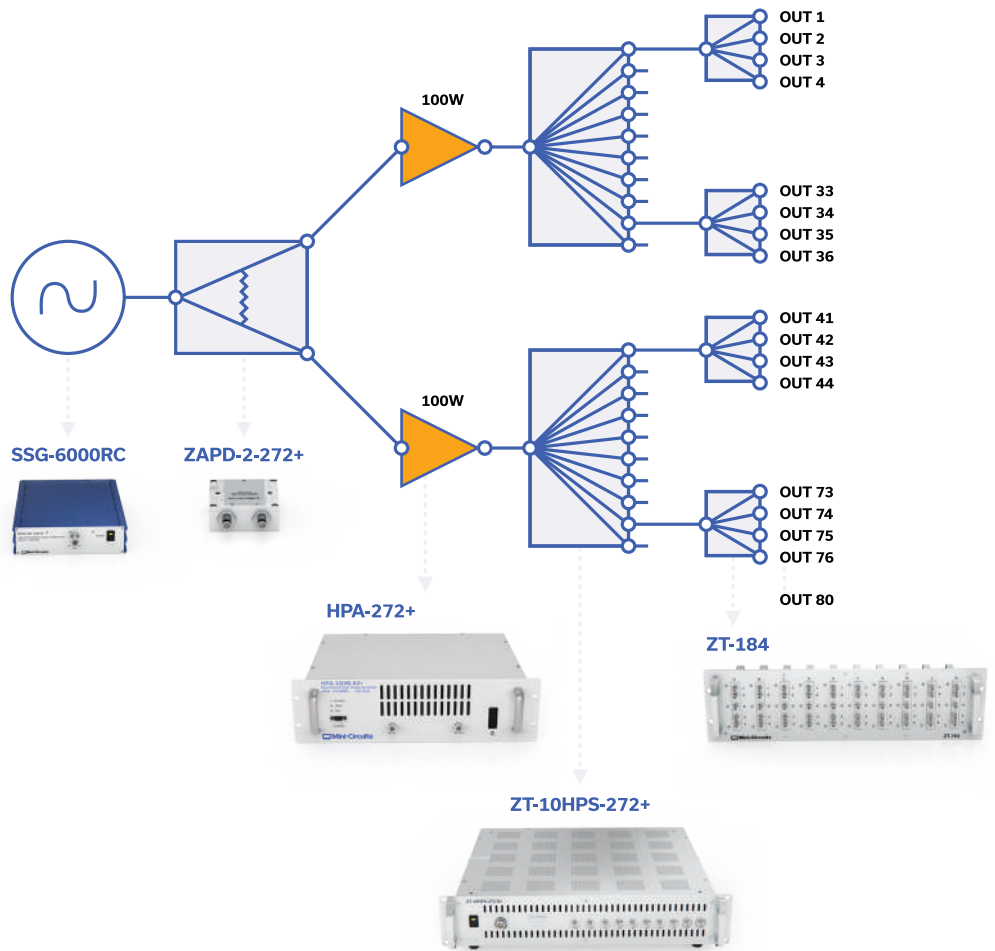

# Integrated Amplifier Systems

## Overview

Mini-Circuits' extensive selection of amplifiers in stock allows us to build integrated amplifier systems for specific test applications. These systems range in complexity from simple multi-channel amplifier racks to designs with additional functions such as gain control, filtering and more.

## Key Benefits

- Wide selection of amplifier modules in stock
- Custom integration
- Rugged designs ideal for demanding lab use
- Fast turnaround
- See p. 48 for high-power rack mount amplifiers



## Close-Up: ZT-228

### 4-Channel Wi-Fi Diplexing Amplifier



Mini-Circuits' ZT-228 is a 4-channel filtered amplifier for Wi-Fi applications. Each of the 4 inputs is split and independently amplified on separate paths for the low and high Wi-Fi bands (centered at 2.4-2.5 and 5.7-5.9 GHz, respectively), with 60 dB rejection of the opposite band. The system is housed in 1U rack-mount chassis with a built-in AC power supply.

## RF Specifications (per channel):

Parameter	Value
<b>Low Band</b>	
Frequency	2.4-2.5 GHz
Gain	17 dB typ
P1dB	16 dBm typ
NF	6 dB typ
High Band Rejection	60 dB typ
<b>High Band</b>	
Frequency	5.7-5.9 GHz
Gain	17 dB typ
P1dB	17 dBm typ
NF	4 dB typ
Low Band Rejection	60 dB typ
Input Power	10 dBm max
Pass Band Return Loss	12 dB typ

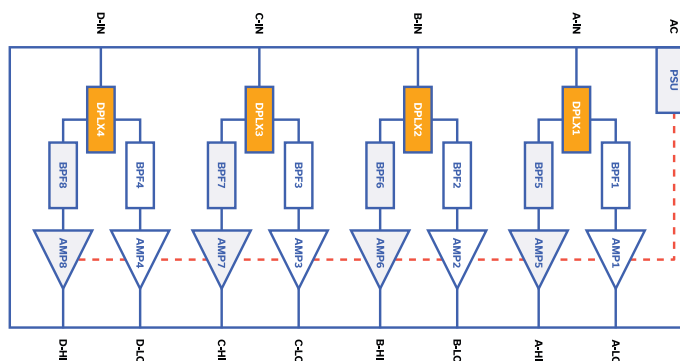

## Close-Up: ZT-270

### 4-Channel Variable Gain Amplifier

Mini-Circuits' ZT-270 is a UHF band variable gain amplifier (VGA) with 4 independently controlled channels. Each channel provides up to 2W output power with 30 dB gain control at 0.25 dB steps. Four separate ON/OFF power switches on the front panel allow any channel to be quickly and safely isolated by terminating the input signal into an internal load. The gain can be controlled via USB or Ethernet (supporting both HTTP and Telnet network protocols).

The system is housed in a compact 19-inch rack chassis (3U height) with SMA connectors, 4 x RF inputs on the front panel and 4 x RF outputs on the rear panel.

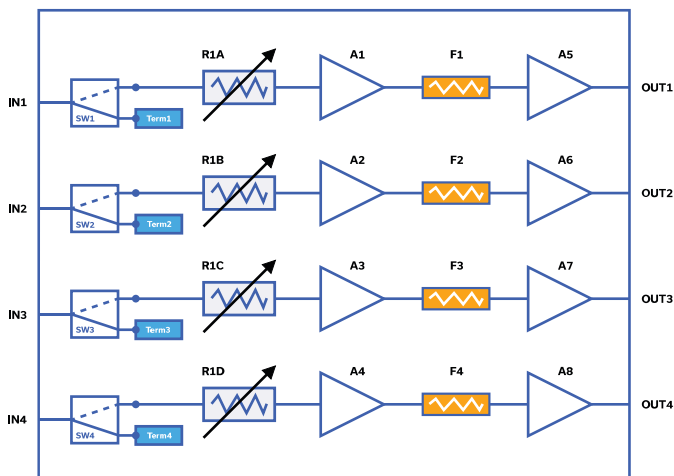

## Specifications (Each Amplifier, 25 °C)

Parameter	Conditions	Min	Typ	Max	Unit
Frequency	-	10	-	300	MHz
Small Signal Gain	@ 0 dB attenuation	50	52	-	dB
Input Return Loss	-	-	18	-	dB
Output Return Loss	-	-	15	-	dB
Attenuation Range	-	0	-	30	dB
Step Size	-	-	0.25	-	dB
Input Power	@ 0 dB Attenuation Setting	-	-	-20	dB

## Approximate Attenuation Settings for 2W Output

Input Power (dBm)	RCDAT Setting (dB)	Output Power (dBm)
4	24	33
0	20	33
3	17	33

## Close-Up: ZT-285

### 12-Channel Amplifier System

ZT-285 is a 12-channel amplifier system, supplied in a 2U height, 19" rack-mount chassis with a single AC mains power supply connection and SMA input / output connectors on the front and rear panels. Each independent amplifier channel operates over 500-2500 MHz, ideal for L-band satellite communications and telecommunications applications, achieving high gain and high directivity across the band.

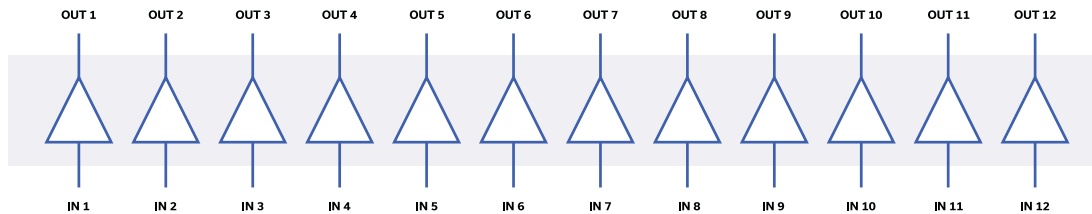

### Specifications (Each Amplifier, 25 ° C)

Gain over Frequency in GHz (dB)					Maximum Power (dBm) Output (1 dB Comp.)			Dynamic Range		VSWR (:1) 1.5-2. GHz		Active Directivity (dB)	
0.5	1.0	1.5	2.0	2.5	Min @ 2 GHz	FL	FU	NF (dB) 1 GHz	IP3 (dBm)		In	Out	
									1 GHz	2 GHz			
37	41.5	41	39	37	33	19	17	2.9	24	26	1.3	1.5	24

# Measurement Solutions

## Overview

- Power Meters
- Signal Generators



# Smart Power Sensors

Power sensors are an essential tool for any RF/microwave test engineer. Mini-Circuits developed its extensive PWR series of smart power sensors to provide an option for any test requirement, budget and experience level.

The series includes a range of high-performance sensors up to 40 GHz supporting measurements of any signal type, from CW / single tone applications to pulsed signals and most modern digital modulations. Input power ranges down to -60 dBm are ideal for measurement of transmitted signals and characterization of components with high loss or rejection (such as filters). Sample rates up to 80 million samples per second allow detailed signal analysis with very fine measurement resolution.

The included measurement software for Windows® walks the user through the power sensor settings, displays measurements and provides powerful data recording and export capabilities. A flexible API is provided with programming instructions and examples to set up automated power measurements in a range of common programming environments.

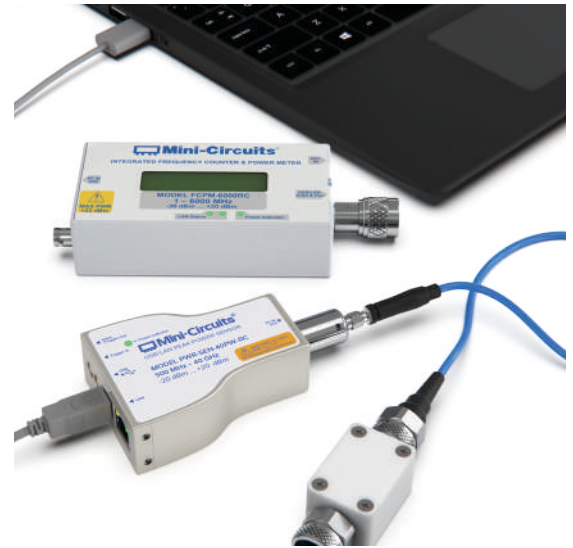

## Peak & Average Power Sensors

### Features & Advantages:

- High performance sensors for measurement of modulated and fast pulsed signals
- Peak, average and statistical (crest factor / duty cycle) analysis of power samples
- Trace the modulation / pulse profiles with time
- Up to 30 MHz video bandwidth, supporting pulse profiling with resolution down to 13ns



### Featured Systems

Model Name	Frequency (MHz)		Input Power (dBm)		Sample Rate (/s)	Video Bandwidth (MHz)		Control	LCD
	Min	Max	Min	Max		Internal	Video Out		
PWR-8P-RC	0.01	8	-60	20	500k	0.1	10	USB & Ethernet	No
PWR-8PW-RC	0.01	8	-60	20	20	10	30	USB & Ethernet	No
PWR-9PWHS-RC (NEW)	0.05	9	-60 (avg) -40 (pk)	20	80M	30	30	USB & Ethernet	Yes
PWR-18PWHS-RC	0.05	18	-60 (avg) -40 (pk)	20	80M	30	30	USB & Ethernet	Yes
PWR-40PW-RC	0.5	40	-20	20	20	10	30	USB & Ethernet	No

## RMS Power Sensors

### Features & Advantages:

- Cost-effective sensors for RMS (average) measurements of power vs. time
- Measure modulated and multi-tone signals
- Measure pulsed signals with moderate duty cycles ( $\geq 2\%$ )



### Featured Systems

Model Name	Frequency (MHz)		Input Power (dBm)		Measurement Speed (ms)	Control	LCD
	Min	Max	Min	Max			
PWR-6LRMS-RC	0.05	6	-45	10	30	USB & Ethernet	No
PWR-6RMS-RC	0.05	6	-35	20	30	USB & Ethernet	No
PWR-9RMS-RC (NEW)	0.05	9	-60	20	0.5	USB & Ethernet	Yes
PWR-18RMS-RC	0.05	18	-60	20	0.5	USB & Ethernet	Yes

## CW Power Sensors

### Features & Advantages:

- Lowest cost sensors for average power measurement of CW single-tone signals
- Ideal for lab testing and signal-level calibration of test systems
- FCPM-6000RC provides both power and frequency measurement with integrated LCD screen.



### Featured Systems

Model Name	Frequency (MHz)		Z0 ( $\Omega$ )	Dynamic Range		measurement Speed (ms)	Control	LCD	Freq Measurement?
	Low	High		Low (dBm)	High (dBm)				
DWR.2.5GHS.75	0.1	2.5	75	-30	+20	30	USB	No	No
PWR-4GHS	0.009	4	50	-30	+20	30	USB	No	No
PWR-6GHS	1	6	50	-30	+20	30	USB	No	No
PWR-6GHS	50	6	50	-45	+10	30	USB	No	No
FCPM-6000RC	1	6	50	-30	+20	30	USB & Ethernet	Yes	Yes
PWR-8GHS	1	8	50	-30	+20	30	USB	No	No
PWR-8GHS-RC	1	8	50	-30	+20	30	USB & Ethernet	No	No
PWR-8FSI	1	8	50	-30	+20	10	USB	No	No

## Easy to Use Software

### Graphical User Interface (GUI) For Windows

Mini-Circuits' full software and support package including user guide, Windows GUI, API, programming manual and examples can be downloaded free of charge (refer to the last page for the download path).

#### A comprehensive set of software control options is provided:

- GUI for Windows - Simple software interface for control via Ethernet and USB.
- Programming / automation via Ethernet:
  - Complete set of control commands which can be sent via any supported protocol.
  - Simple to implement in the majority of modern programming environments.
- Programming / automation via USB:
  - DLL files provide a full API for Windows with a set of intuitive functions which can be implemented in any programming environment supporting Net Framework or ActiveX.
  - Direct USB programming is possible in any other environment (not supporting Net or ActiveX).

Please contact [testsolutions@minicircuits.com](mailto:testsolutions@minicircuits.com) for support.

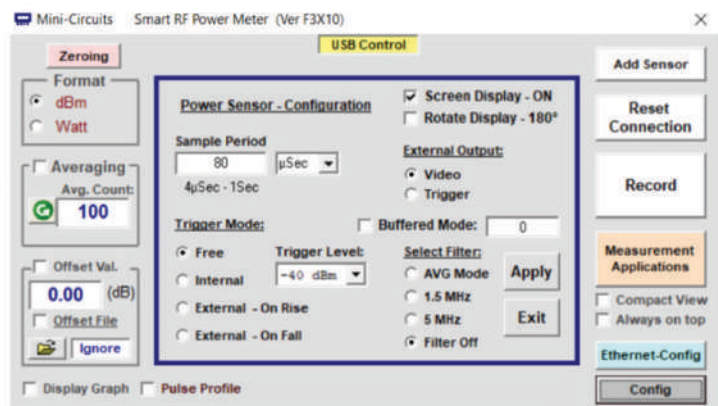
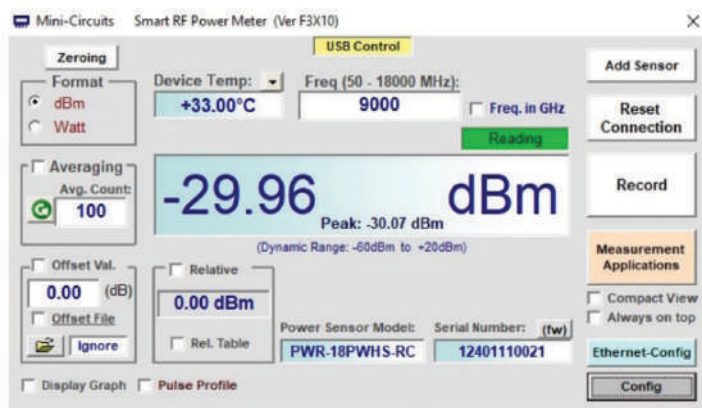

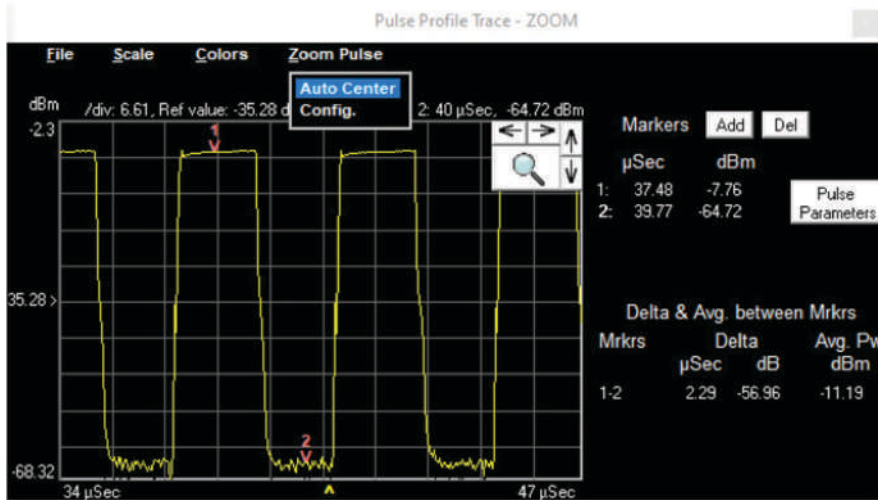

### Calculated Parameters

Parameter	Value
Pulse Width (mSec)	0.044
Pulse Period (mSec)	8.020
Duty Cycle (%)	0.55
Rise Time (μs)	3.54
Fall Time (μs)	3.54
Pulse Pwr ( dBm)	0.75
Cycle Avg. ( dBm)	-19.70
Crest Factor (dB)	20.45
Over Shoot (dB)	0.98

## Calibration

Mini Circuit support the calibration of its Smart Power Sensors and Synthesized Signal Generators products.

For more information contact [testsolutions@minicircuits.com](mailto:testsolutions@minicircuits.com)



## SSG-44G-RC (100 MHz TO 44 GHz)

# Wideband Sig Gen

High Quality, Cost-Effective Millimeter Wave Signal Generator for Your Test Bench or ATE

### Features

- 100 MHz to 44 GHz, -40 to +17 dBm
- Low phase noise & excellent harmonic rejection
- CW & pulsed outputs with 0.5  $\mu$ s pulse width
- Automated sweep & hop list sequences
- Compact package with Ethernet & USB control
- SSH secure Ethernet communication

### Common Applications

- 5G FR1, FR2 & FR3, millimeter wave radio
- Semiconductor burn-in & life testing
- Automated production test systems
- Benchtop signal generator
- Wideband LO source

### Complete Series:

Model Number	Frequency	Output Power
SSG-6000RC	25 MHz to 6 GHz	-65 to +14 dBm
SSG-6001RC	1 MHz to 6 GHz	-70 to +15 dBm
SSG-15G-RC	10 MHz to 15 GHz	-50 to +16 dBm
SSG-30G-RC	10 MHz to 30 GHz	-47 to +23 dBm
SSG-30GHP-RC	10 MHz to 30 GHz	-47 to +28 dBm
SSG-44G-RC	100 MHz to 44 GHz	-40 to +17 dBm

LEARN MORE

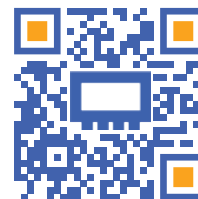

## Signal Generators

Mini-Circuits' SSG series offers reliable and repeatable signal sources with full automation via Ethernet or USB, available at a fraction of the cost of traditional benchtop signal sources. Other high-end signal generators on the market often come with advanced features many customers don't need. Our generators provide a versatile, high-performance signal source at a fraction of the cost.

### Common Applications

- LTE / 5G / Wi-Fi (2.4-7.2 GHz) testing
- Dynamic Frequency Selection (DFS) simulation
- Lab and field test equipment
- High volume production testing / ATE



### Catalog Models

Model Name	Frequency		Resolution (Hz)	Output Power		Control
	Low (MHz)	High (MHz)		Low (dBm)	High (dBm)	
SSG-6000RC	25	6,000	3-6	-65	+14	USB & Ethernet
SSG-6001RC	1	6,000	3-6	-70	+15	USB & Ethernet
SSG-15G-RC	10	15,000	0.1	-50	+16	USB & Ethernet

### Close-Up: SSG-15G-RC

Ultra-Wideband Synthesized Signal Generator

- 10 MHz to 15 GHz with 0.1 Hz resolution
- CW and pulsed output signals
- 60 dB typical output dynamic range
- Configure automated sweep, hop and pulse sequences
- USB & Ethernet control



# Panel-Mounted Structures

## Overview

Mini-Circuits' panel-mounted structures provide clean, organized management of cable runs and connections in complex, high-volume test setups. Multiple connector adapters, power splitters, directional couplers and other essential RF components and test accessories can be integrated efficiently within the test system. Custom configurations are available upon request.

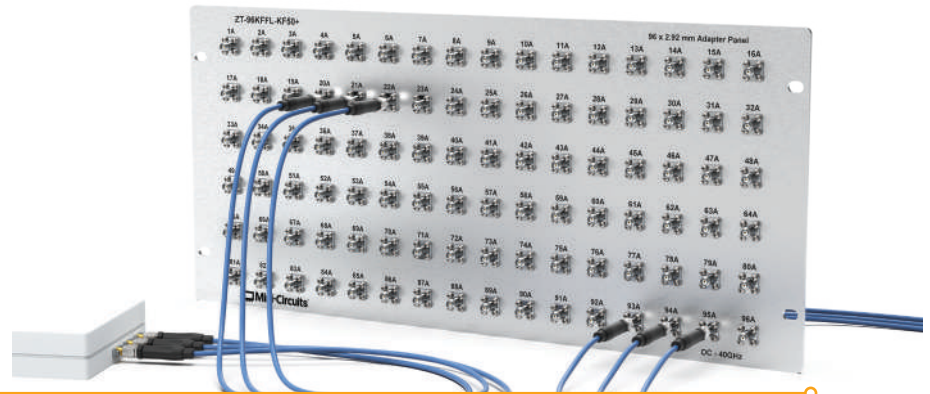

## Key Benefits

- Organized management of cable runs in busy test setups
- Choose from adapters, splitters couplers and other coaxial components
- Wide variety of standard configurations
- Custom configurations with fast turnaround

## Types/families

- Patch panels
- Passive component panels

# Patch Panels

## Key Benefits

- Tidy cable connections with patch panels directly on the rack
- Convert between connector types
- Use as "connector savers" to reduce wear on high-cost test equipment connectors

## Featured Configurations

### 2ZT-32KFFL-KF50+ | DC to 40 GHz

- 32 x connector adapters
- 2.92 mm female to 2.92 mm female
- 19" width, 2U height

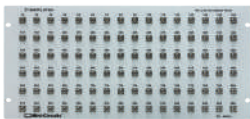

### ZT-182 | DC to 11 GHz

- 48 x connector adapters
- N-type female to N-type female
- 19" width, 4U height



### ZT-183 | DC to 18 GHz

- 48 x connector adapters
- N-type female to SMA female
- 19" width, 4U height

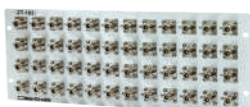

### ZT-240 | DC to 6 GHz

- 24 x connector adapters
- N-type female to N-type female
- 19" width, 3U height
- Extended mounting brackets



### ZT-396 | DC to 18 GHz

- 16 x connector adapters
- N-tSMA female to SMA female
- 19" 19" width, 1U height



### ZT-312 | DC to 18 GHz

- 12 x connector adapters
- N-type female to SMA female
- 19" width, 1U height



### ZT-314D | DC to 18 GHz

- 80 x connector adapters
- SMA female to SMA female
- 19" width, 2U height

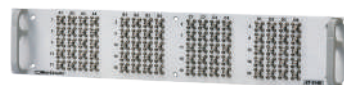

## Passive Component Panels

**Choose from 1000+ passive components in stock:**

- Power splitter / combiners
- Directional couplers
- High power fixed attenuators
- Simplify test setups by integrating accessories into the rack

### ZT-275 | DC to 18 GHz

- 10 x 30 dB fixed attenuators, 2W
- 19" width, 2U height
- SMA female connectors



### Featured Configurations

#### ZT-230 | 1 to 500 MHz

- 8 x 10 dB directional couplers
- 19" width, 2U height
- SMA female connectors

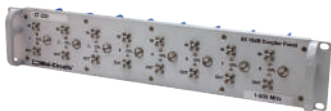

#### ZT-333 | 100 to 900 MHz

- 4 x 2-way splitter/combiners
- 19" width, 1U height
- SMA female connectors



#### ZT-256 | DC to 18 GHz

- 12 x 2-way resistive splitter/combiners
- 19" width, 2U height
- SMA female connectors

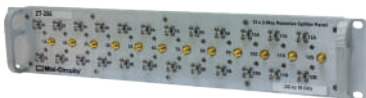

#### ZT-245 | 300 to 1000 MHz

- 1 x 8-way splitter/combiner
- 19" width, 1U height
- SMA female connectors



### ZT-277 | 600 to 6000 MHz

- 3 x 4-way splitter/combiners
- 19" width, 1U height
- SMA female connectors



### ZT-255 | 500 to 8500 MHz

- 8 x 2-way splitter/combiners
- 19" width, 2U height (black anodized panel)
- SMA female connectors

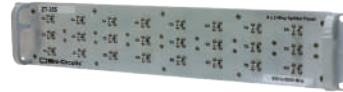

### ZT-257 | 600 to 6000 MHz

- 4 x 4-way splitter/combiners
- 19" width, 1U height
- SMA female connectors



### ZT-229B | 0.5 to 600 GHz

- 16 x 2-way splitter/combiners
- 19" width, 2U height
- SMA female connectors

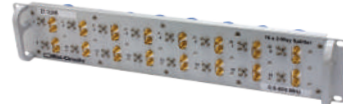

### ZT-184 | 500 to 6000 MHz

- 10 x 4-way splitter/combiners
- 19" width, 3U height
- SMA female connectors



### ZT-222 | 350 to 6000 GHz

- 20 x 2-way splitter/combiners
- 19" width, 4U height
- N-type female connectors



### ZT-304 | 500 to 6000 MHz

- 8 x 2-way splitter/combiners
- 19" width, 1U height
- SMA female connectors



# Signal Distribution

## Overview

For test systems requiring distribution of signal to many DUTs, Mini-Circuits' signal distribution systems combine splitter/combiners and directional couplers to expand test signal into multiple channels. Amplifiers can also be incorporated to minimize path loss and manage signal power from input to output.

## Key Benefits

- Wide selection of splitter/combiners and directional couplers in stock
- Bandwidths up to 65 GHz
- RF input power up to 250W
- Rack-mounted, panel-mounted or benchtop structures

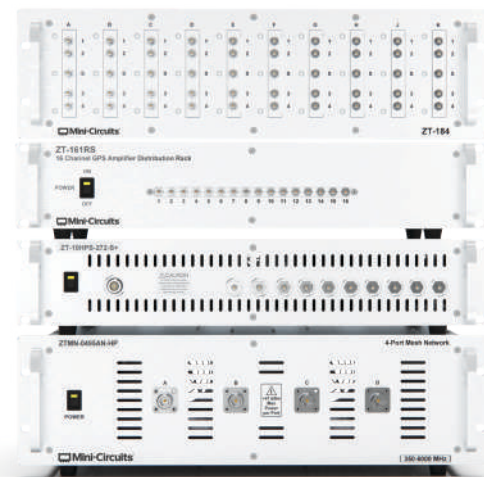

## Standard Configurations

Model Name	Description	Frequency Range (MHz)	# of Inputs	# of Outputs	Connector Type
ZT-104	16-Way Active Splitter - 10 MHz Reference Distribution Module	10	1	16	BNC
ZT-201	20x2-Way Splitter Array	350 to 6000	20	40	N-type
ZT-207	6x 2-Way Splitter Array	350 to 6000	6	12	N-type to SMA
ZT-208	4x 4-Way Splitter Array	380 to 4600	4	16	N-type
ZT-246	12 x 2-Way Splitter Array	350 to 6000	12	24	SMA
ZT-161RS	16-Way Active L-Band Splitter	900 to 2250	1	16	SMA
ZT-338	8-Way Active L-Band Splitter	950-2150	1	8	SMA

## Close-Up: ZT-161RS

### L-Band Active Splitter Module

- 16-way active splitter
- Ideal for GNSS signal distribution applications
- 20+ dB gain per channel



### Specifications (25 ° C)

Parameter	Conditions	Min	Typ	Max	Unit
Frequency	-	1200	-	1600	MHz
Gain	Per Channel	20	-	-	dB
VSWR	-	-	1.4	-	dB
Isolation	Between Outputs	-	25	-	dB
Input Power	-	-	-	-25	dBm

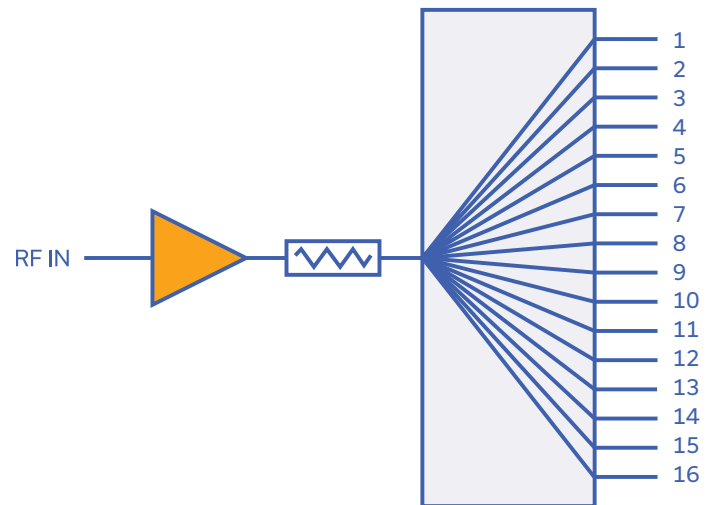

# Custom Systems

## Overview

Our experience in the test space has evolved according to your needs. The diversity of customer requirements for highly customized test solutions has led us to build our business around principles of flexibility, reliability, economy and speed. Our wealth and variety of components in stock allows along with our in-house design, manufacturing and applications expertise allows us to develop a wide range of custom equipment for your special requirements at highly competitive cost and with fast turnaround.

## Key Benefits

- Designed and built to your unique test requirements
- All systems fully characterized during production
- On-site integration available when needed
- Full GUI and API for programming with your native test software



# Lab Accessories

Mini-Circuits' extensive selection of thousands of stocked catalog components offers everything you need to supply your RF test lab. If you're considering one of our integrated systems for your test setup, be sure to check out our connectorized components for all your needs on the bench.



## Connector Types:

BNC, N-Type, SMA, SMA reverse polarity, SMA quick connect, SMP, 3.5 mm, 2.92 mm, rugged 2.92, 2.4 mm, rugged 2.4 mm, 1.85mm



DC TO 110 GHz

## Adapters

Wide Variety of Connector Types

- All gender combinations
- Standard, right-angle, bulkhead and NMD mounting types
- Low loss and excellent VSWR
- Rugged construction

DC TO 110 GHz

## Amplifiers

250+ Connectorized Models

- High power amplifiers up to 100W
- Class A and Class AB linear amplifiers
- Low noise amplifiers, NF as low as 0.4 dB
- Ultra-wide bandwidths with flat gain
- Rugged designs with built-in protections

DC TO 110 GHz

## Attenuators

200+ Connectorized Models

- Precision fixed
- Digital step
- Voltage variable
- Input power up to 100W
- Attenuation from 0 to 50 dB

DC TO 67 GHz

## Coaxial Cables

375+ Models in Stock

- Precision test cables
- VNA cables
- Interconnect cables
- Custom assemblies available on request

### Connector Types:

BNC, MMCX, N-Type, SMA, SMP, 3.5 mm, 2.92 mm, rugged 2.92, 2.4 mm, rugged 2.4 mm, 1.85mm

DC TO 65 GHz

## Couplers

190+ Connectorized Models

- Directional, bi-directional, dual-directional and RF tap
- Power handling up to 250W
- DC passing and DC blocking
- 50 and 75Ω designs



**Connector Types:**

BNC, N-Type, SMA, 2.92mm, 2.4mm, 1.85mm

DC TO 65 GHz

## DC Blocks

Wideband, High-Voltage

- DC input up to 200V
- Low insertion loss
- Excellent return loss



**Technology for every need:**

Cavity, ceramic resonator, lumped LC, LTCC, microstrip, suspended substrate, waveguide

DC TO 87 GHz

## Filters

For Every Application

- 500+ connectorized models in stock
- Low pass, band pass, high pass, band stop, diplexers and triplexers
- Custom designs with fast turnaround

METROLOGY-GRADE

## Gauges

Optimize Performance

- Check connector interfaces for optimal performance before mating
- Avoid unreliable measurements due to misaligned or damaged connectors
- Available for SMA, BNC and N-Type connector types
- Easy calibration



DC TO 3000 GHz

## Impedance Matching Pads

Seamless 50/75Ω Conversion

- Ideal for testing 75Ω devices
- Excellent VSWR (1.05 to 1.3)
- Flat attenuation vs. frequency
- BNC, SMA and N-Type connector options

10 MHz TO 40 GHz

## Power Detectors

Wide Bandwidth and Dynamic Range

- Input power ranges spanning -60 to +20 dBm
- Peak and RMS measurement types
- Linear-in-dB response
- Fast response time

1 TO 650 MHz

## Phase Detectors

For Monitoring and Levelling Circuits

- High DC output vs. phase, up to 1V
- Low DC offset
- Coaxial and Surface Mount Models

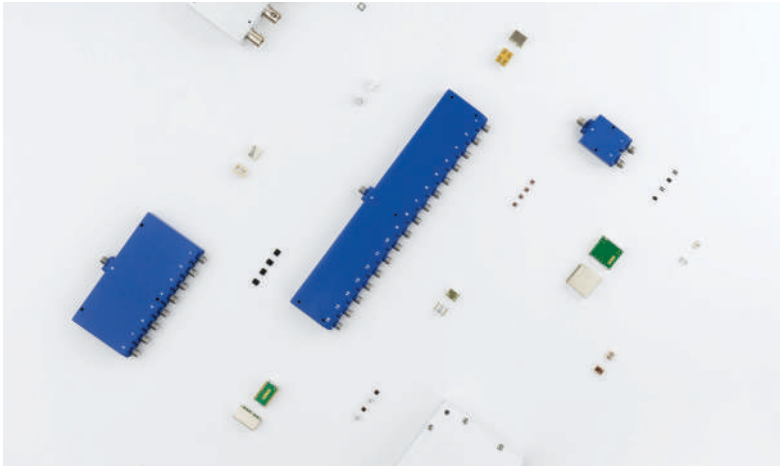

DC TO 67 GHz

## Power Splitters & Combiners

300+ Connectorized Models

- High DC output vs. phase, up to 1V
- Low DC offset
- Coaxial and Surface Mount Models

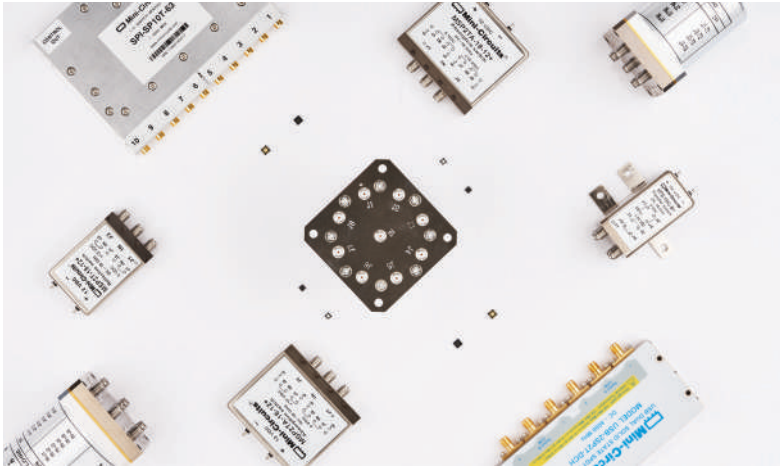

DC TO 67 GHz

## Switches

Ultra-Reliable

- Switch configurations from SPDT to SP16T
- Patented electromechanical switches capable of 10-million cycles without failure
- Solid-state switches with high isolation up to 110 dB

DC TO 110 GHz

## Terminations

Up to 50W

- Excellent return loss
- 50 and 75Ω models
- Wide selection of connector types

### Connector Types:

DIN 1.0/2.3, BNC, TNC, SMB, SMA, SMP, N-Type,  
2.92mm, 2.4mm, 1.85mm

PRECISION TOOLED

## Wrenches

Simplify Connection and Disconnection

- Eases connections in tight spaces and crowded port configurations
- Prevents damage to connectors

**Pocket-sized SMA wrenches ideal for crowded port configurations**



**8-in-lbs calibrated break-over torque wrenches for SMA, 3.5 mm, 2.92 mm, 2.4 mm and 1.8 mm**



// Been working with Mini-Circuits for over 12 years at this company and my previous one. The basic standard has always been quick, timely response to quote requests, rarely late on deliveries, and no quality issues at all. A true pleasure to deal with, and I wish more of my suppliers would work and perform as well as Mini-Circuits does.

— **Mark P.**  
BAE SYSTEMS

