

Good Light & Environment, Superior Yield & Returns.



National High-tech Enterprise (NHTE)  
Specialized, Sophisticated, and Novel SMEs



Tel: 18106967090

Website: <https://www.xmgoodlight.com/>

Address: Room C, 201, No. 34, Guanri Road, Software Park Phase II,  
Torch High-tech Zone, Xiamen City

天之诺<sup>®</sup>  
TIANZHINUO

禽之乐<sup>®</sup>

GAEFLF<sup>®</sup>

Chicking<sup>®</sup>  
CHICKING

**Intelligent Farming Lighting**

Xiamen Good Light Technology Co., Ltd.

Contact Information for International: +86 15260400606  
(Same number for WeChat and WhatsApp.)



## Corporate Honors



## Company Profile

Xiamen Good Light Technology Co., Ltd. established in 2014, is a high-tech enterprise specializing in the research, production, sales and service of lighting control systems for livestock and poultry farming.

Good Light Technology has been awarded the title of National High Technology Expertise, Specialized, Sophisticated, and Novel SMEs, Innovative SMEs, Technological SMEs, and has passed the ISO9001 quality management system certification. It has also obtained a number of core technological intellectual property rights. At the same time, it has signed a strategic cooperation agreement for talent development and cultivation with universities, achieving a joint venture of industry-university-research, and conducting cooperative research and talent cultivation. Good Light Technology attaches great importance to product research and development innovation, aiming to meet the needs of livestock and poultry farming. It focuses on using automation, intelligence, AI + big data technology to achieve the goals of livestock and poultry farming being unmanned, low cost, high survival rate, energy conservation and environmental protection.

In the future, we will adhere to the corporate tenet of "honesty, pragmatism, innovation and excellence", and provide high-quality and efficient services to meet the needs of our customers.

## Intelligent Technology Solution

Ensuring Security and Stability for Mutual Benefit and a Win-Win Outcome.

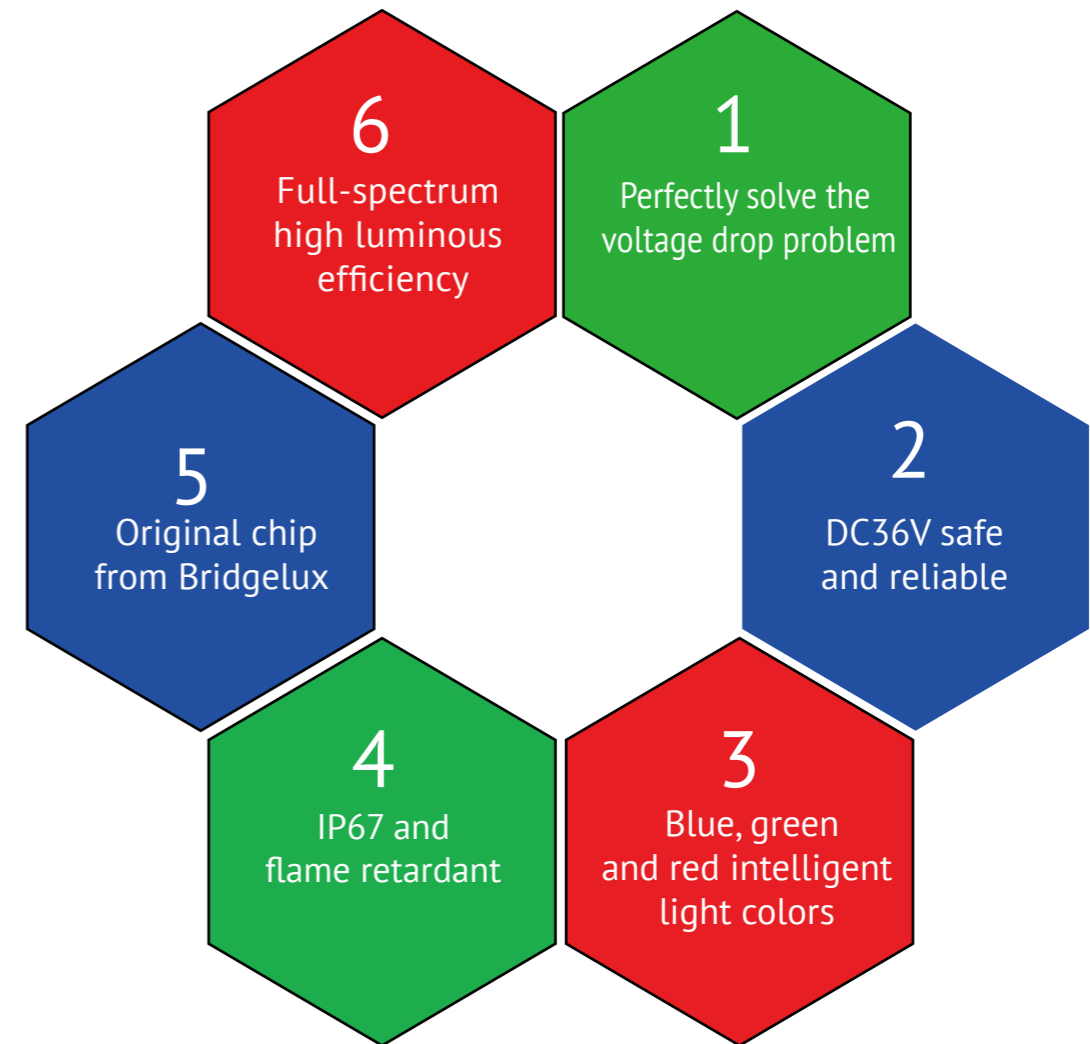

# Technical Principle Of LED Intelligent Multi-color Farming Lighting

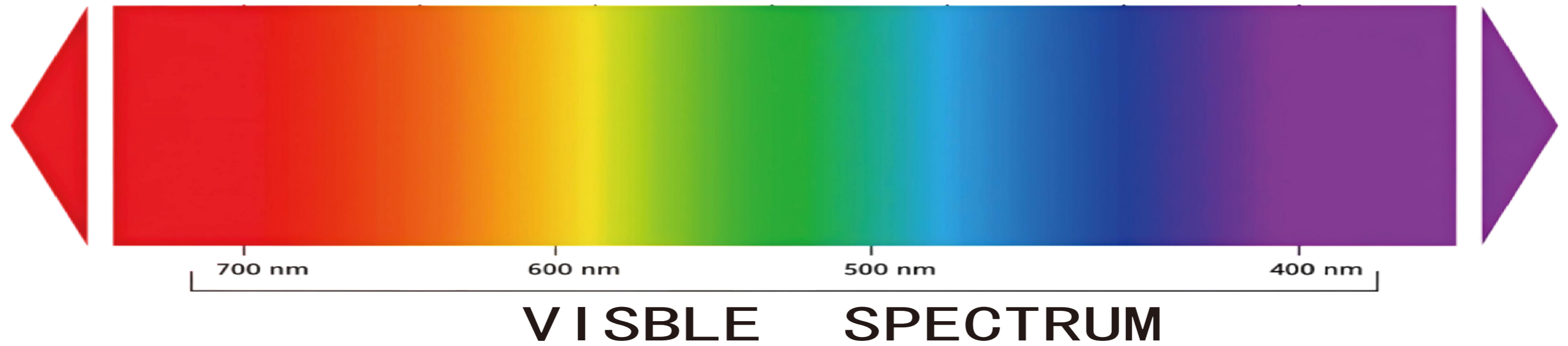

Red Light  
(Added light)

Warm Yellow Light  
(Main color temperature)

Green Light  
(Added light)

Blue Light  
(Added light)

Purple Light  
(Added light)

White Light  
(Main color temperature)

Warm White Light  
(Main color temperature)

●

- Reduce the aggression of poultry
- Promote sexual maturity
- Increase egg production rate

●

- Simulating the light of dusk
- Help poultry relax
- Induces natural rest behavior

●

- Create a gentle lighting environment
- Reduce stress in poultry
- Improve comfort level

●

- Enhance the immunity of poultry
- Improve growth performance
- Be relatively friendly to vision

●

- Enhance the vigilance of poultry
- Increase activity level of poultry
- Promote growth and development of poultry

●

- Assists in synthesis of vitamin D in poultry body
- Have potential disinfectant and sterilizing effects

●

- Illumination close to sunlight
- Promote normal activities of poultry
- Regulate growth rhythm of poultry

# Intelligent Farming Lighting Control System

TZN-KZXT-6010/6020/6050

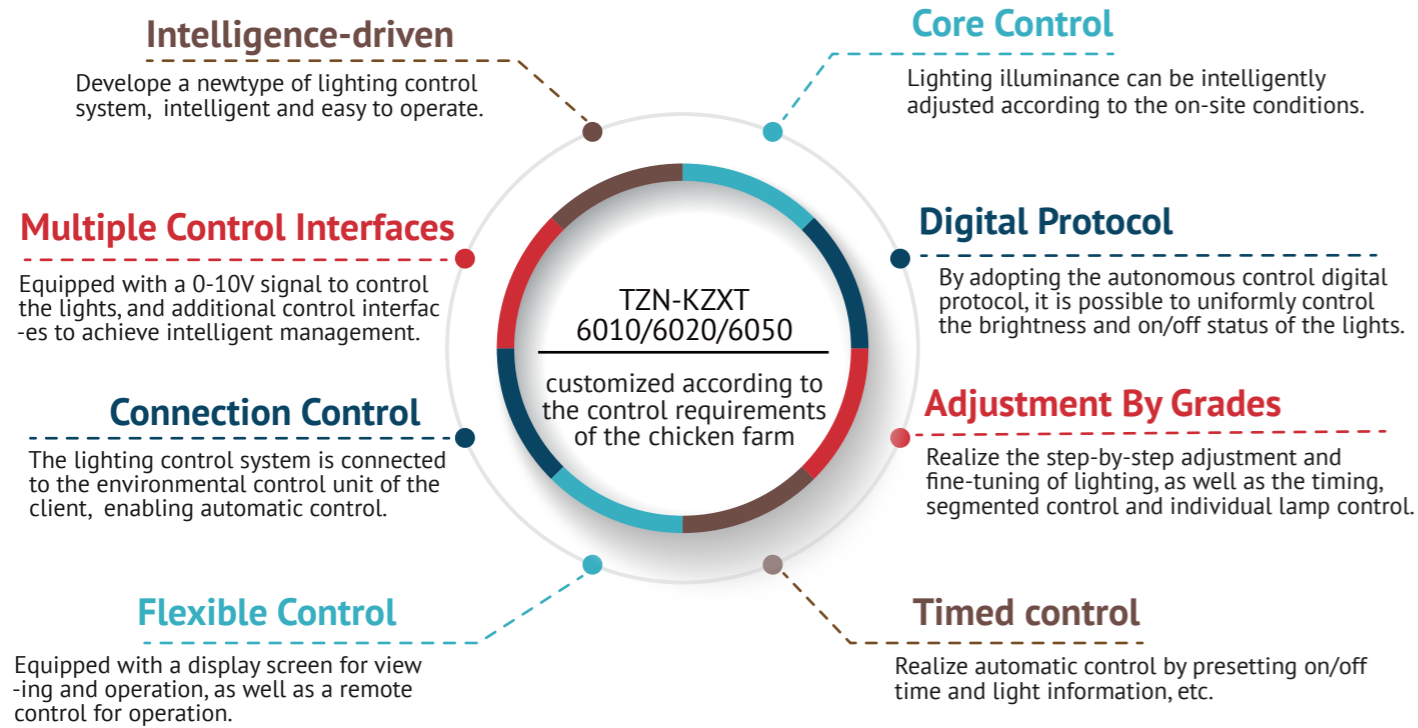

Intelligent Farming Lighting - Function Diagram

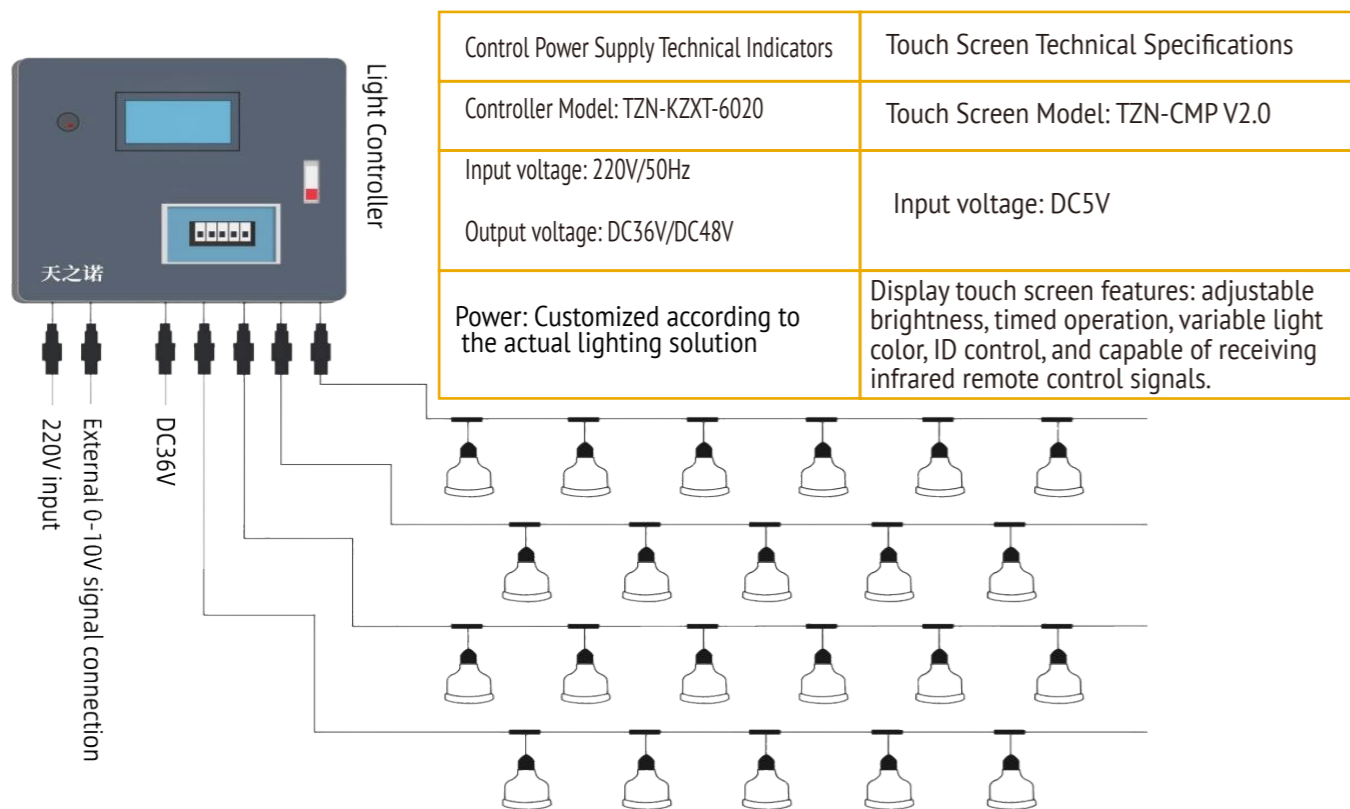

# LED Patent Products Introduction

## PAR35 LED Poultry Light Bulb

TZN-YZLED6.5WDC36V



1.Power	6.5W
2.Voltage	DC36V
3.Color Temperature	Full spectrum / 3000K / 4000K / 5000K + blue light / red light / green light / UV light
4.Luminous Flux	1000LM
5.Interface	E27 / Male-Female Connector
6.Illuminance	Uniform
7.Flicker	Flicker-free
8.Voltage Drop	Has no effect on the lights
9.Characteristics	Anti-corrosion, resistant to acid and alkali, easy to clean, easy to install
10.Lamp Life	50000H
11.IP Rating	IP67
12.Application	Mainly used in free-range farms / cage farms



## S50 Farming Lamp

TZN-S50 4W DC36V



1.Power	4W
2.Voltage	DC36V
3.Color Temperatur	Full spectrum / 3000K / 5000K + blue light / green light / red light / UV light
4.Luminous Flux	600LM
5.Interface	Waterproof male-female connector
6.IP Rating	IP67
7.Illuminance	Uniform
8.Application	Suitable for cage farming (4 tiers, 6 tiers, 8 tiers, etc.)

# LED Patent Products Introduction

## LED Poultry Light Tube

TZN-T5LNL6.5WDC36V  
/ TZN-T5LNL2WDC36V



1.Power	6.5W / 2W
2.Voltage	DC36V
3.Color Temperature	Full spectrum / 3000K / 4000K / 5000K + blue light / red light / green light / UV light
4.Luminous Flux	1000LM/160LM
5.Interface	Waterproof male-female connector (The length of the connecting line can be adjusted)
6.Illuminance	Uniform
7.Flicker	Flicker-free
8.Voltage Drop	Has no effect on the lights
9.Characteristics	Anti-corrosion, resistant to acid and alkali, easy to clean, easy to install
10.Lamp Life	50000H
11.Size	1200MM
12.IP Rating	IP67
13.Application	Mainly used in free-range farms / cage farms

## LED Batten Lamp

TZN-TP188C03  
/ TZN-TP308C06



1. Input Voltage	AC180V-265V/50-60Hz
2.Input Current	100mA / 170mA
3.Power	18±2W / 30±2W
4.Power Factor	≥0.95
5.Color Temperature	6500±200K
6.Luminous Flux	≥2000LM / ≥4000LM
7.Color Rendering Index	≥80
8.Operating Environment Temperature	-25°C-55°C
9.Execution Standard	GB7000.1-2015/GB7000.201-2008
10.Application	Can be used in hatcheries, food factories, slaughterhouses, breeding farms, etc.

## TZN-R8PRO

TZN-R8PRO DC36V6.5W/  
TZN-R8PRO DC48V6.5W/  
TZN-R8PRO DC220V6.5W



1. Power	6.5W
2.Voltage	DC36V/DC48V/DC220V
3.Color Temperature	Full spectrum / 3000K / 5000K
4.Luminous Flux	1000LM
5.Illuminance	Uniform
6.Flicker	Flicker-free
7.Voltage Drop	Has no effect on the lights
8.Characteristics	Corrosion-resistant, acid and alkali resistant, easy to clean, easy to install
9.Lamp Life	50000H
10.Luminous angle	120°
11.IP Rating	IP67
12.Application	Mainly used in free-range farms / cage farms

## Flood Lamp Blue Light

TZN-TGDLG20W



1.Power	20W
2.Voltage	DC5V
3.Color Temperature	Blue light
4.Characteristics	Blue light, rechargeable, requires wearing sunglasses when using
5.IP Rating	IP67
6.Application	Mainly used for assisting in catching chickens

# Intelligent Control System

## Intelligent Light Controller 6010(digital screen)



Control Power Supply Technical Indicators	Digital Screen Technical Specifications
Controller Model: TZN-KZXT-6010	Digital Screen Model: TZN-SMP V1.0
Input voltage: 220V/50Hz	Input voltage: DC5V
Output voltage: DC36V/DC48V	
Power: Customized according to the actual lighting solution	Characteristics of the display digital tube: 3-digit 7-segment red light, capable of receiving infrared remote control signals

## LED Mosquito Repellent Lamp

TZN-LED15WAC90-265V



1.Power	15W
2.Voltage	AC90-265V
3.Luminous Flux	1500LM
4.Interface	E27
5.Application	Mainly used for repelling mosquito



## Intelligent Light Controller 6020(7inch Touch screen)



Control Power Supply Technical Indicators	Touch Screen Technical Specifications
Controller Model: TZN-KZXT-6020	Touch Screen Model: TZN-CMP V2.0
Input voltage: 220V/50Hz	Input voltage: DC5V
Output voltage: DC36V/DC48V	
Power: Customized according to the actual lighting solution	Display touch screen features: adjustable brightness, timed operation, variable light color, ID control, and capable of receiving infrared remote control signals.

## Cable Waterproof Lamphoder Connecting Line

TZN-DLXE27



1.Material	National Standard 3C Cable
2.Interface	E26, E27, male-female connectors (other interface options available upon request)
3.Applicable	Used with LED Poultry Light Bulbs. Customized according to the requirements of the chicken house.
4.Feature	Flame-retardant(UL1581), waterproof



# Product Application Projects

Broiler Free-range Farm



Breeder Free-range Farm



— Broiler Cage Farm —

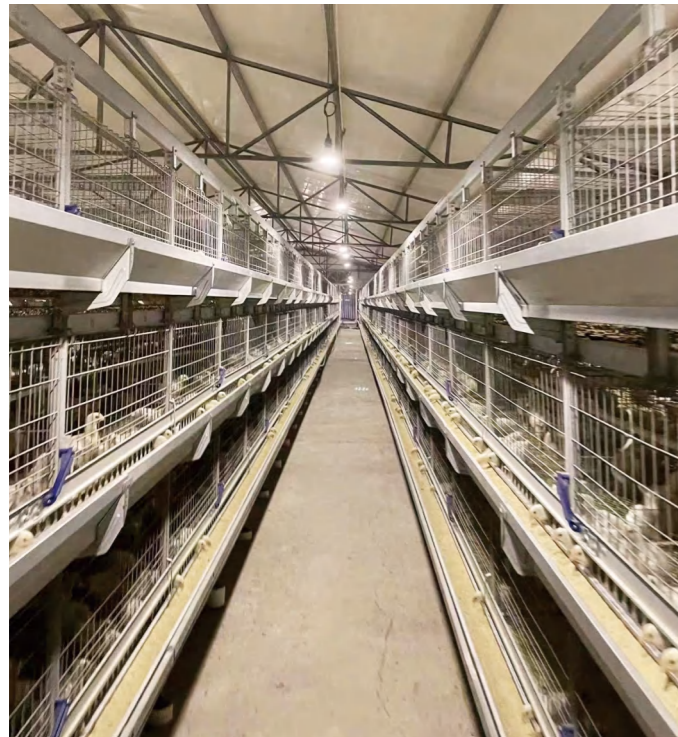
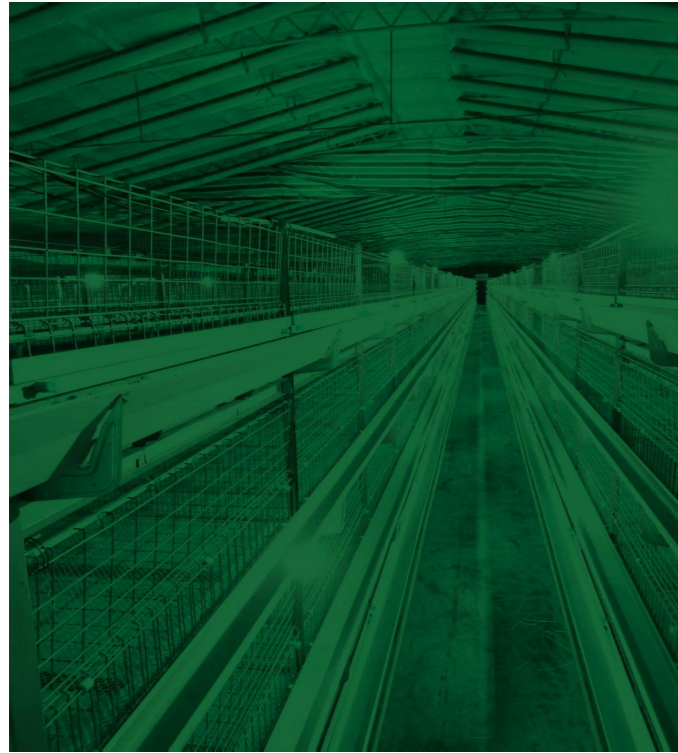

— Commercial Layer Cage Farm —

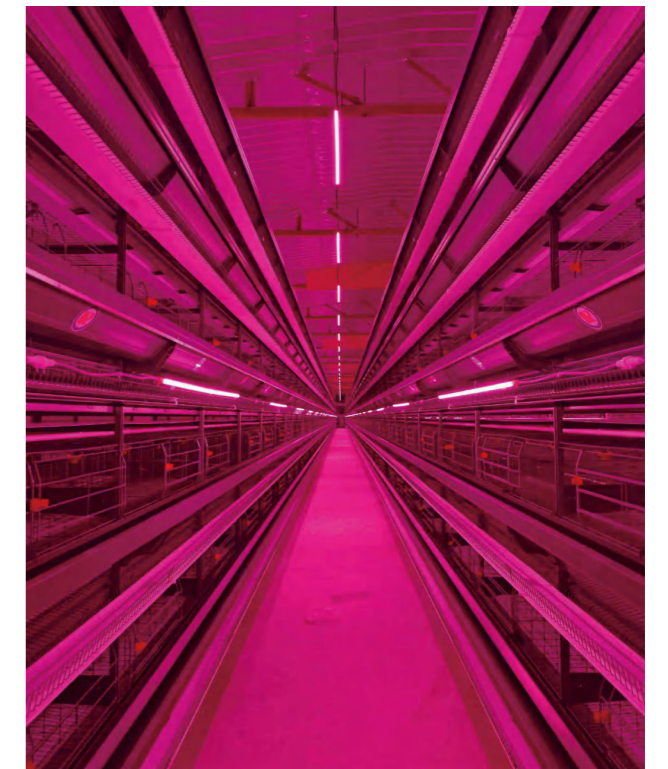

# Company Qualifications and Patent Certificates

Those who know how to change will win, and those who keep their integrity and innovate will advance. For an enterprise to remain invincible in the market, it must rely on technological innovation. Good Light Technology has established a research and development team in its scientific research, constantly keeping an eye on the latest technologies in the industry, increasing its independent research and development efforts, converting the latest technology into the strength for enterprise competition, continuously developing new products, and enhancing the competitiveness of the enterprise. It now holds multiple patent certificates for lighting systems and livestock and poultry farming lighting equipment, and has obtained certifications such as ISO9001, after-sales service system certification, data security, data security, and CE.

## Breeder Cage Farm



# Quality Assured, Reliability You Can Trust.



# Together, we build the future.

