



seabreath®  
wave energy

*Turning Ocean Motion into Clean, Predictable Energy*

Founder & CEO: **Luigi Rubino**

Location: Italy

Stage: Seed – Deep Tech / Ocean Energy

SEABREATH SRL - Strada Val Parma, 18 (località Vigatto) 43124 Parma – ITALY CF - PI: 02862900343 - REA PR-272956



# Problem

Wave motion is one of the planet's largest energy resources, yet it has remained untapped because:

- Existing wave energy technologies are too expensive.
- They are fragile and require continuous maintenance.
- They have low efficiency.
- They are not scalable.
- They cannot withstand the marine environment.

**Result: a huge potential market left completely unserved.**





# Opportunity

The world needs energy that is:

- Stable and predictable — not intermittent like solar or wind.
- Generated close to shore, where 40% of the global population lives.
- Sustainable, with minimal environmental footprint.
- Easily integrated into beaches, islands, and nearshore infrastructure.
- Viable for remote and off-grid locations.

Wave energy has the potential to become the major renewable source, but only with a technology that truly works.





# Solution

Seabreath is a modular, floating, multi-chamber OWC WEC that finally overcomes the sector's long-standing technological barriers.

## Key features:

- Delivers ~2× the efficiency of conventional OWC-type WECs.
- No submerged mechanical components → exceptional reliability and uptime.
- Lower CAPEX and minimal OPEX.
- Fully modular design: deployable as an energy breakwater pier, floating, or nearshore.
- Near-zero environmental impact, with additional benefits such as coastal protection and enhanced marine habitats.



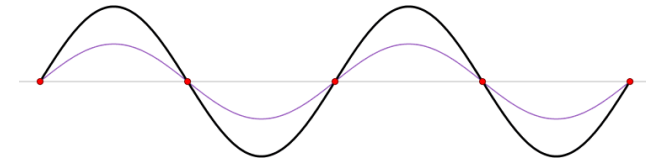

# Working

Seabreath is a modular, floating, multi-chamber OWCs-type WEC that overcomes the sector's historical limitations.

## How it works:

- Wave motion causes the water level inside the chambers to rise and fall.
- As the wave rises, it compresses the air and pushes it through the delivery duct.
- As the wave falls, it draws air in through the turbine's exhaust.
- External valves compensate for absolute air/water volume variations, increasing overall efficiency.
- The resulting near-constant airflow drives a unidirectional turbine, which can achieve up to twice the efficiency of the traditional bidirectional turbines used in OWC systems.

L'onda fa variare il livello nei settori

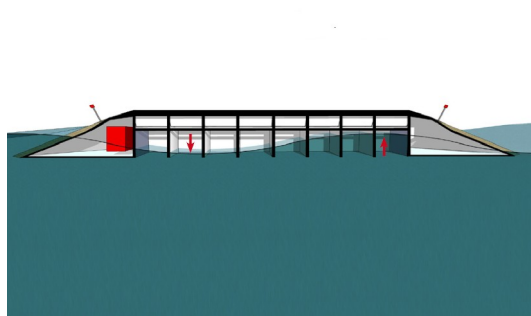

Quando il livello scende è aspirata dalla condotta A  
Quando il livello sale l'aria è spinta nella condotta B

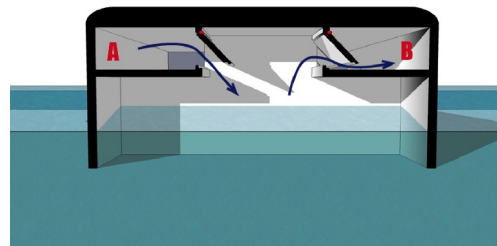

Il circolo d'aria alimenta la turbina

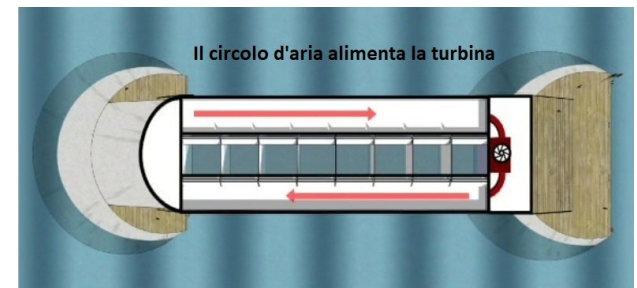

# Why now?

- The crisis of fossil fuels and their environmental impact are accelerating the shift toward alternative energy sources that are renewable and non-polluting.
- Wave energy, with its vast and highly predictable potential, is increasingly attracting the interest of governments, public authorities, and energy producers.
- Other alternative sources are gradually revealing structural and environmental limitations.



# Market

**Wave Energy TAM: hundreds of billions.**

**Main segments:**

- Islands and remote communities.
- Ports and coastal infrastructure.
- Coastal defense + energy (hybrid solutions).
- Offshore industries (oil & gas → decarbonization).
- Utilities and governments with net-zero targets.

**No global leader exists yet.  
Seabreath can become the first**

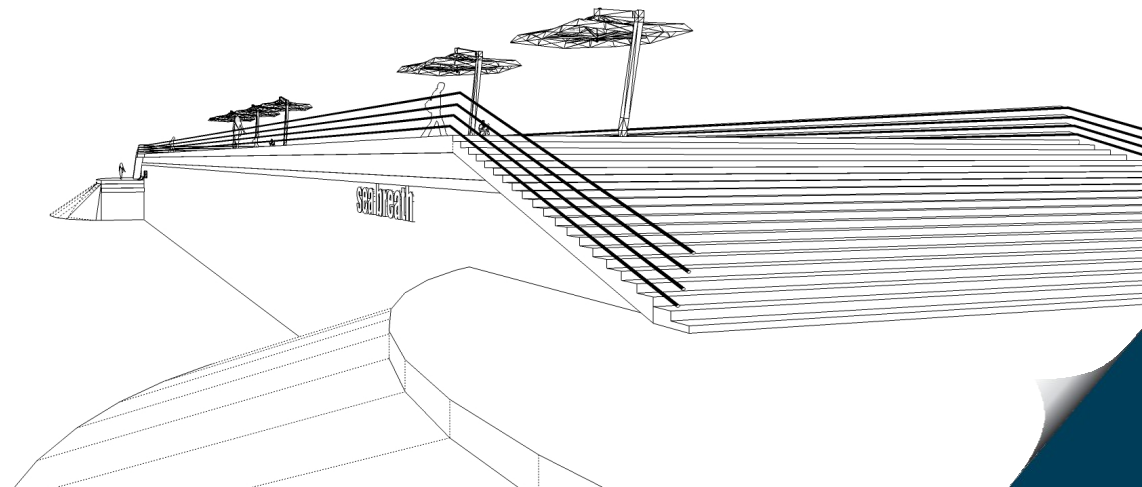

# State of art/Traction

Seabreath Wave Energy is the first wave-power technology truly competitive with other renewable energy sources.

The main companies currently active in wave energy are: Oceanlix, OceanEnergy, CorPower Ocean, Sinn Power, and Seabased.

## Traction:

- Laboratory validation at university facilities completed.
- Entering TRL6 with open-sea testing.
- Growing interest from foreign governments, public authorities, ports, islands, and coastal infrastructure operators.

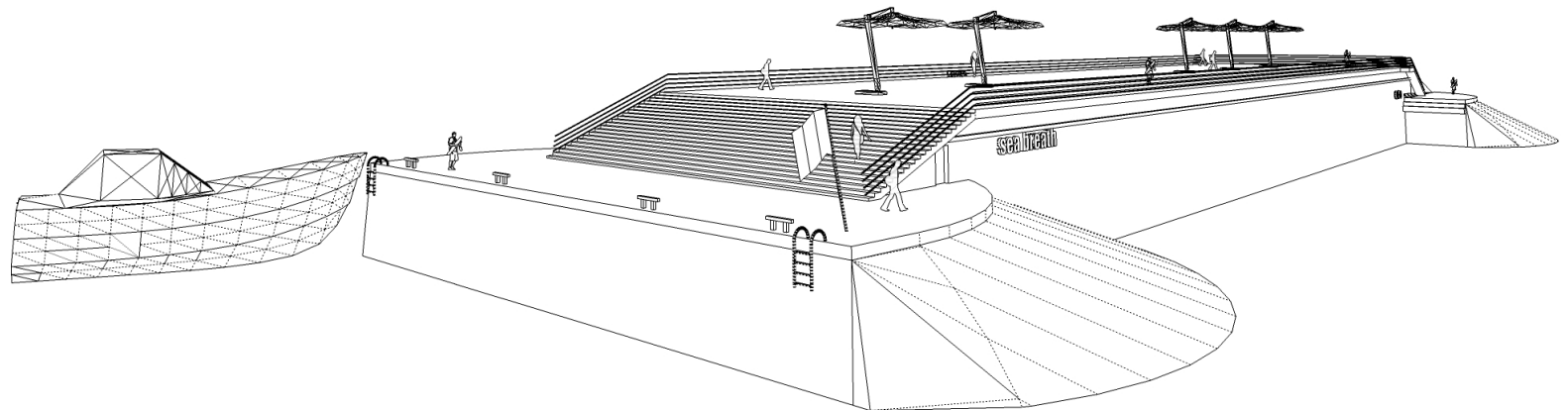

# Go-to-market



## Phase 1 – Pilot (TRL6–7)

- Prototyping and demonstration installations in ports and islands.
- Partnerships with public institutions and universities.

## Phase 2 – Early Commercial

- Sale of modules to ports and coastal communities.
- Integration with existing infrastructure.

## Phase 3 – Global Scale-Up

- Industrial-scale production.
- International licensing.
- Standardization as a breakwater solution.

# Advantages



- High efficiency
- Breakwater functionality
- Creation of usable space
- Low environmental impact (recycled materials, coastal and marine-life protection, very low acoustic emissions—comparable to a breath)
- Modular system with low production, transport, and installation costs
- High resistance to adverse conditions
  
- **Seabreath is designed to become the industrial standard for wave energy.**

# Business model

- Sale of Seabreath modules (CAPEX).
- Maintenance contracts (OPEX).
- Revenue-sharing agreements with ports and islands.
- Licensing to offshore operators.
- Partnerships with utilities and governments.

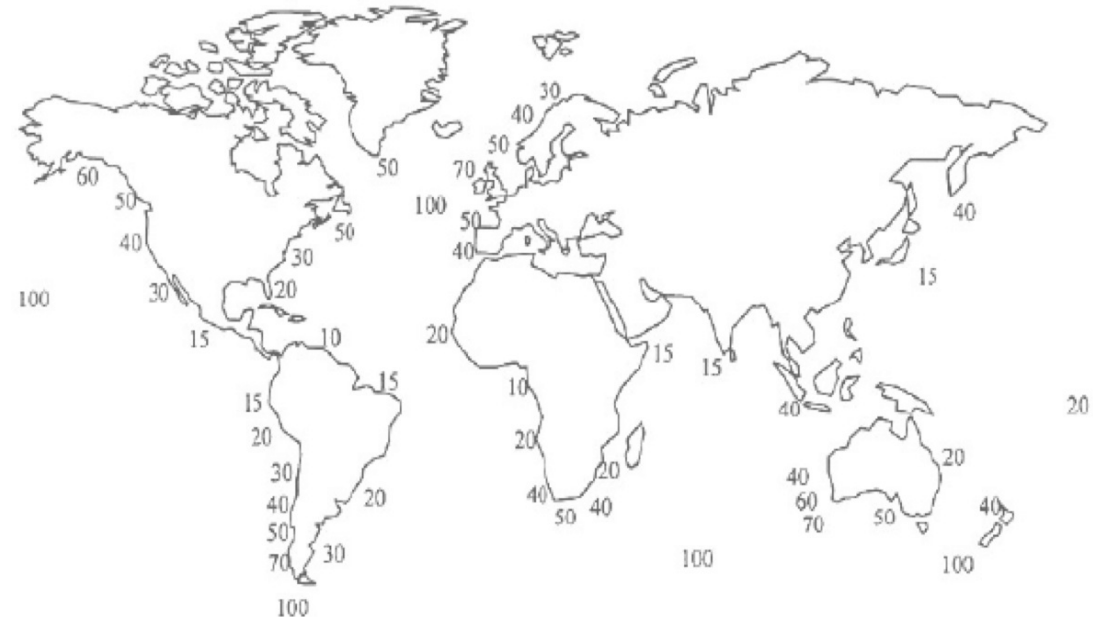

# Summary financial projections

- Gross margin per module: 40–60%.
- Customer payback period: 4–6 years.
- Estimated energy cost competitive with offshore wind and solar.
- High scalability → increasing margins over time.

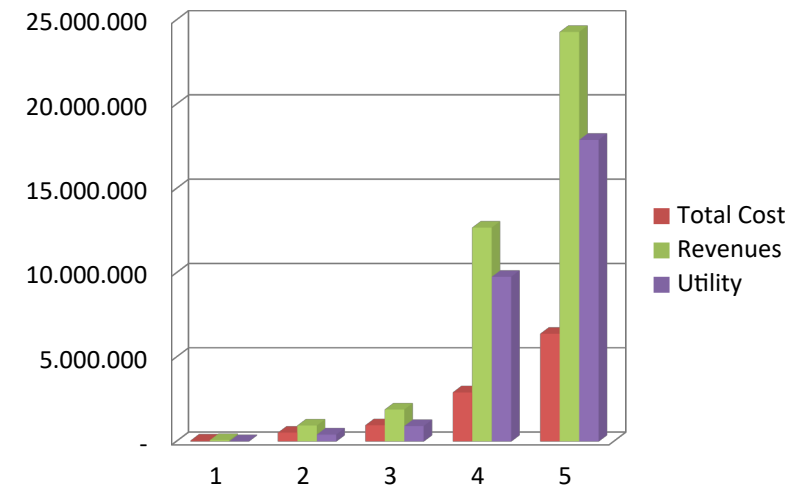



# Team



- 1 Graduate in Economics & Business – administration and project management
- 1 Senior Mechanical Engineer – construction and site supervision
- 1 Naval Engineer – design and testing
- 1 Industrial Engineer – specialist in green economy, materials research, and logistics
- 1 Electronics Engineer – electrical and electronic system design
- 1 Designer – graphic and industrial design
- 2 Specialized Technicians – technical fabrication and assembly
- **Collaborations:** 1 Technology park, 1 specialized Marine-Engineering firm, 2 companies focused on marine electronic design, 1 University, 1 metal-mechanical company, 1 manufacturer of 3D-printed turbines.

# Roadmap

**2026–2027:** TRL6 — engineering, open-sea testing, optimization.

**2028–2029:** TRL7 — first commercial pilots.

**2030–2031** — Industrialization and initial sales.

**2031+** — Global scale-up and utility partnerships.



# Ask

**We are opening to new partners and investors to:**

- Complete TRL6 and open-sea testing
- Launch pre-industrialization
- Scale toward the first commercial installations

**Target round: €X (confidential negotiation)**

**Runway: 18–24 months**

**Use of funds:**

- Advanced R&D and prototyping
- Open-sea testing
- Industrialization
- Business development





# Final vision

To make wave energy a fundamental, reliable, and competitive power source, transforming the world's coastlines into sustainable energy infrastructures.

**Seabreath aims to become the global standard for wave energy.**





# Contact:

## Seabreath LLC

Str. Val Parma, 18

43124 - Parma (Vigatto) - ITALY

Tel.: mobile+39-347-5884093 / +39-0521-645437

Mail: [info@seabreath.it](mailto:info@seabreath.it)

Web: <https://www.seabreath.it/>



Parma IT, 22/04/2026

***We're ready to move fast. If you are too, let's schedule a follow-up***

***Thank you for your attention***