



www.ergonresearch.it
info@ergonresearch.it

Lorenzo Mazzei (R&D Program Manager)

Email: lorenzo.mazzei@ergonresearch.it

Mobile: +39-3358225482

The information contained in this document is Ergon Research S.R.L. proprietary and is disclosed in confidence.
It is the property of Ergon Research S.R.L. and shall not be used, disclosed to others or reproduced, without the express written consent of Ergon Research S.R.L.

The gaps we fill



Provide specialized expertise

The development of innovative and high-performing products needs increasingly specific knowledge.



Overcome resource constraints

Complex engineering projects often must be carried out with limited resources (time, manpower, or tools).

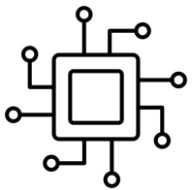

Give access to advanced tools

Challenging problems require solutions that can be achieved only with customized solutions, state-of-the-art software and huge computational resources.

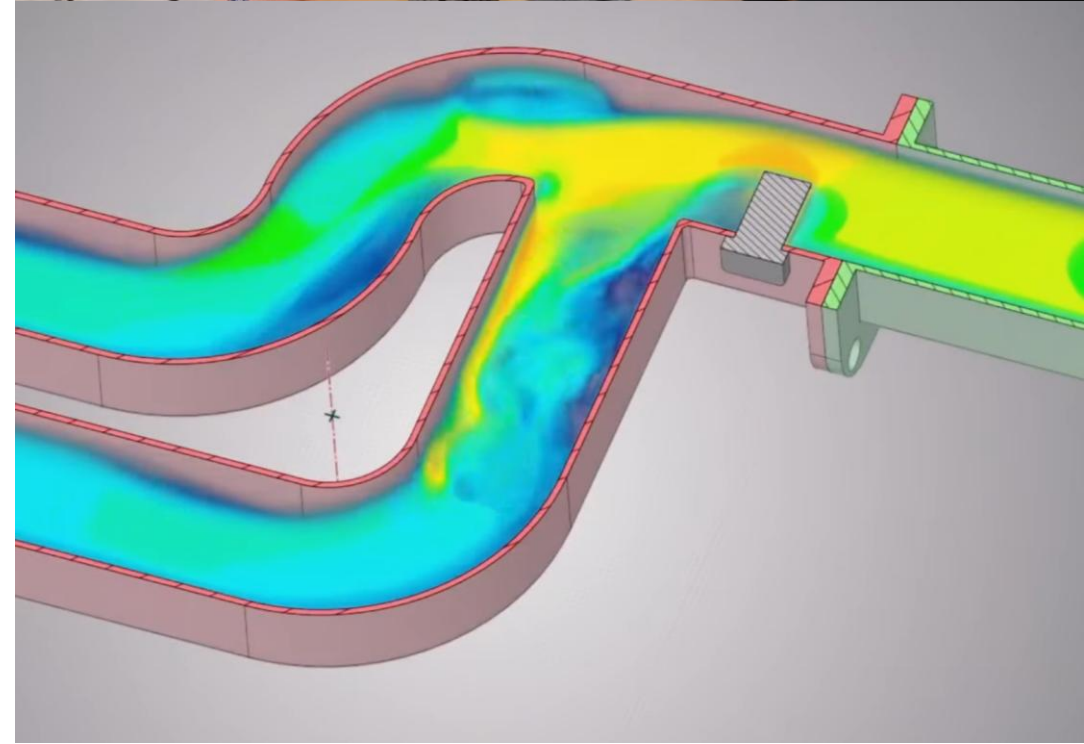
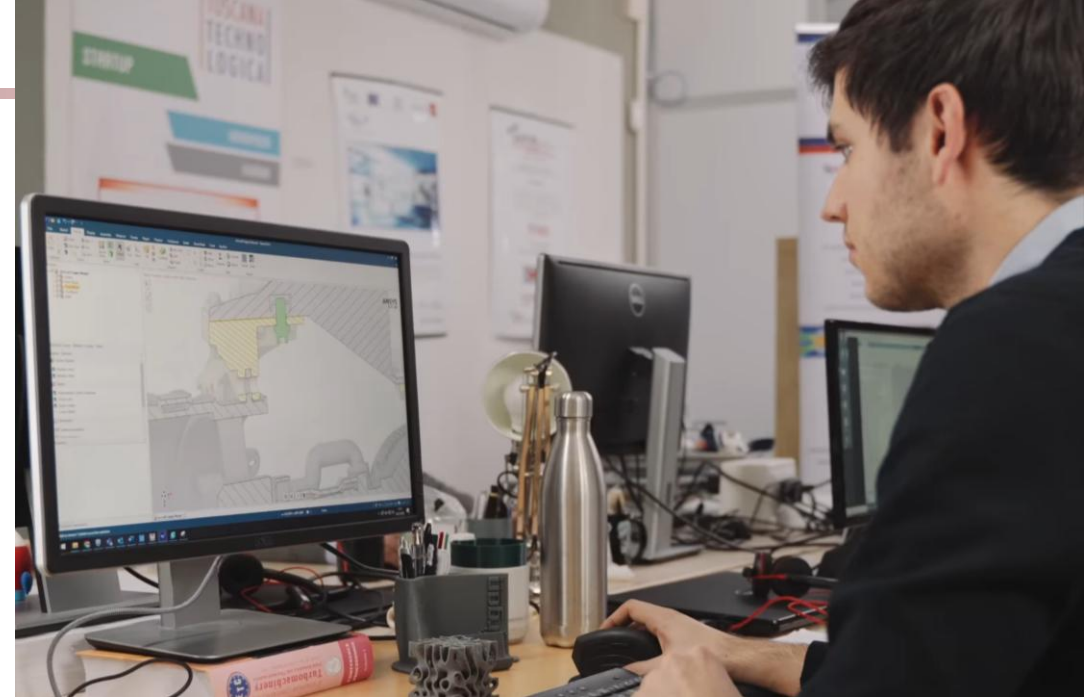

Our history

- **Ergon Research** is a consulting and research firm based in **Florence, Italy**.
 - We supply specialized services for **Research & Development & Innovation (R&D&I)**.
 - Extreme focus on **thermo-fluid** components and systems.
 - Originated from the academic **Heat Transfer and Combustion Group**.
 - Former **spin-off** of the **University of Florence (UNIFI)**.
- Today's key features:
 - 35 full-time resources, 12 of which have a **PhD**.
 - Internal high-performance computing (HPC) cluster with 1000+ cores.
 - Recognized as an **Innovative SME**.

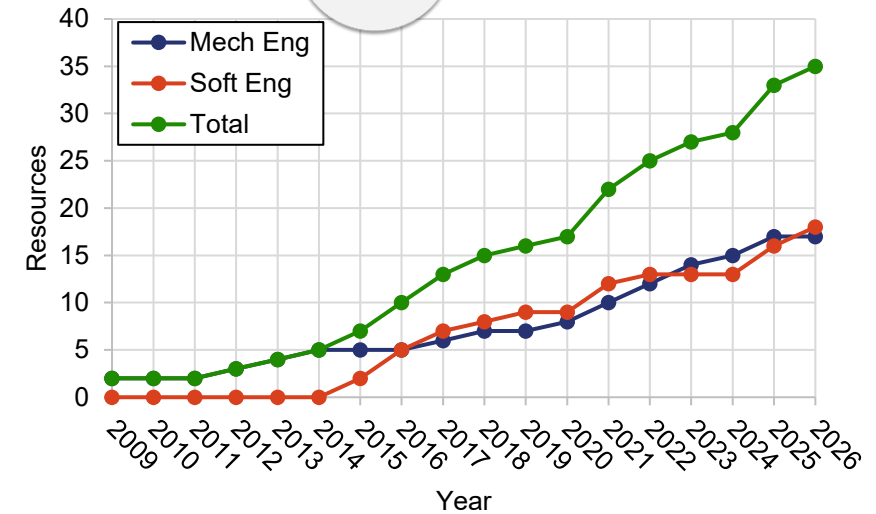

2008

Founded as High-Tech SME

2010

Collaboration with large industrial OEMs



2011

Partner in FP7 projects (aeronautics)

2012

Approved as University of Florence Spin-Off

2016

Team of 10 people and new headquarters



2017

Software development team integration



2019

Coordinator of ACCENTO



CLEAN AVIATION

2023

Participation to Horizon Europe and Clean Aviation projects



EUROPEAN DEFENCE FUND
EUROPEAN UNION

2024

Participation to EuroHPC and EDF projects



Copyright 2026
Ergon Research SRL.
All rights reserved.

Our strength

Integration of advanced **simulation** and **experimental** testing, **software** development, **theoretical** aspects.



SIMULATIONS

CFD - Computational
Fluid Dynamics

Multiphysics

Power plant simulations

Flow Networks

Machine performance



EXPERIMENTS

Test rig design

Instrumentation design and development

Laboratory testing

Data acquisition and post-processing tools



CODING

Maintenance and development of customer
proprietary software

Development of dedicated calculation tools for
aerothermal design and analysis

Development of dedicated CFD models and solvers



RESEARCH

Optimization

Innovative solutions

Procedures and best practices definition

Training

International research project

Main sectors

Aerospace

PowerGen / Oil&Gas

Defense

Transportation

Thermal Management

Energy Transition





Simulations

Nozzle thrust vectoring

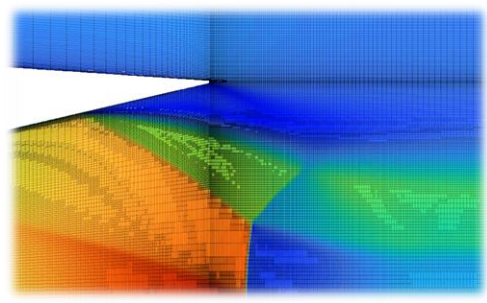

Jet noise

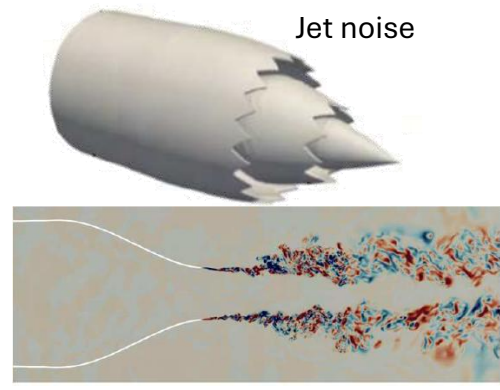

External aerodynamics

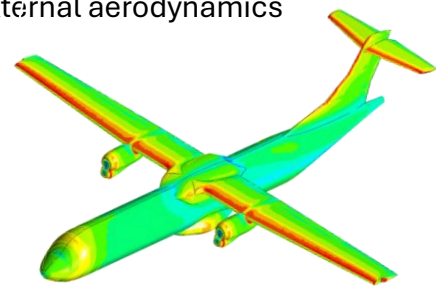

Turbomachinery aerodynamics and cooling

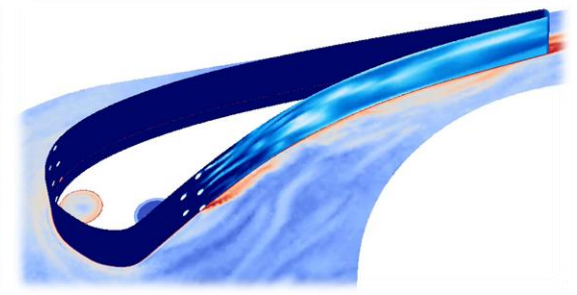
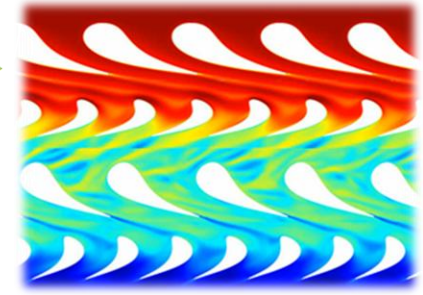

Design of AM heat sinks and heat exchangers

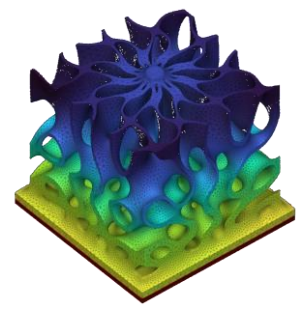

Transient battery modelling

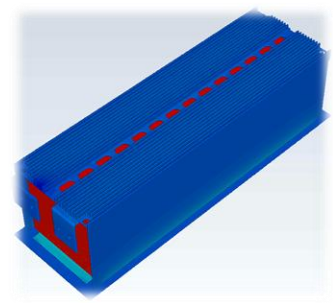

Electric motors cooling

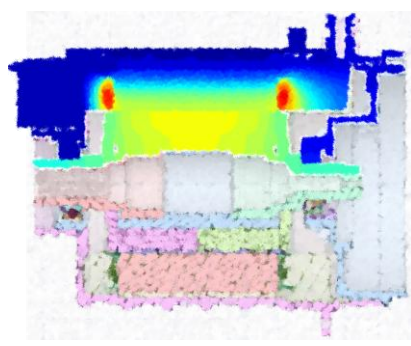

Inverter cooling

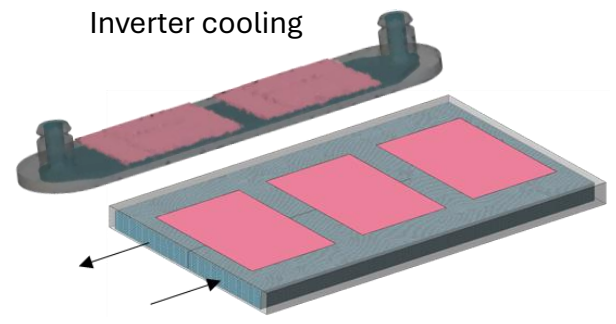

EV charging station cooling

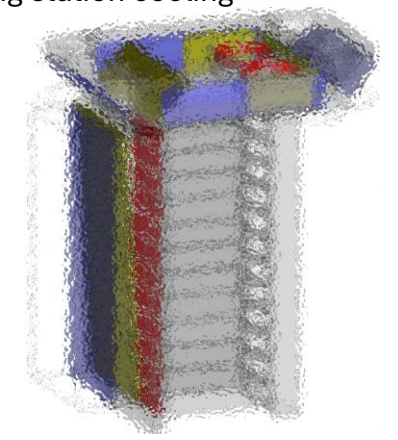

Aeroacoustics damping

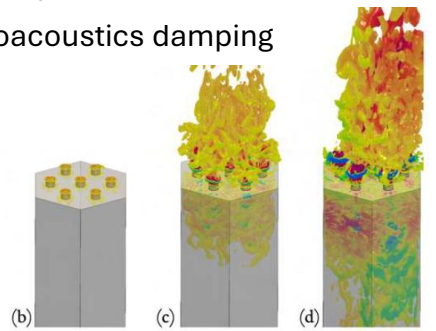

Combustion technologies

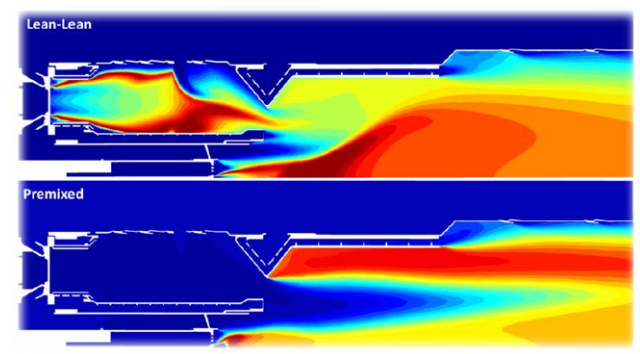

1D MBSE of powertrains, powerplants, fluid distribution systems

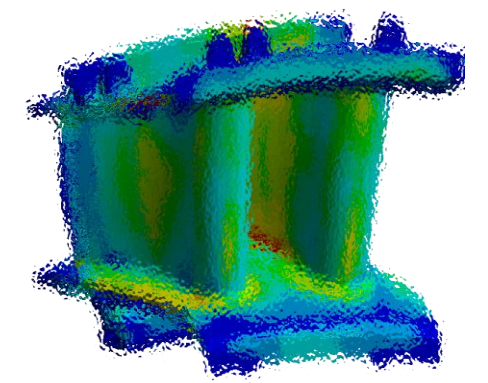
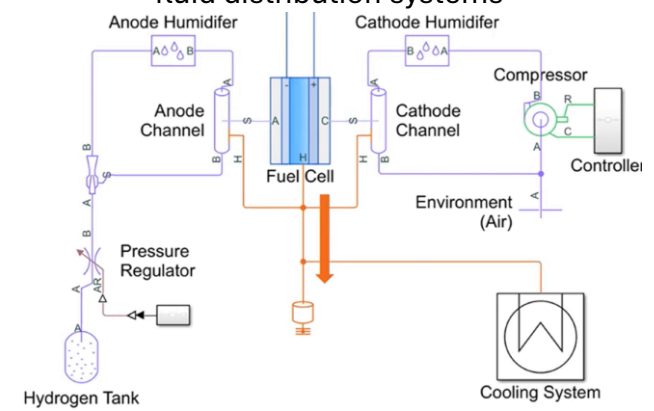

Copyright 2026 Ergon Research SRL. All rights reserved.



Experimental testing

- **Applications:** Aero, Thermal, Combustion
- **Turnkey hardware:** Design + Manufacturing + Certification
 - Cooled/uncooled rakes (temperature, emissions)
 - Test articles, test rigs, up to entire test cells
- **Testing:** collaboration with third-party partners
 1. **Air:** up to 60 kg/s and 30 bar
 2. **Fuels:** Jet A-1, NG, H₂, NH₃, syngas
 3. **Thermal management fluids:** air, water, oil
 4. **Rotating rigs:** gear-box, gas turbine, stator-rotor cavity
 5. **Measurement techniques:** IR camera, TLC, TSP, T-couples, PSP, gas sampling, PIV, HWA, 3-/5-probe, oil&dye, high-speed camera, borescope, OH*, acoustics

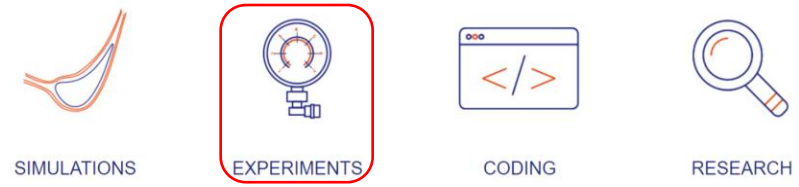

Gearbox test rig



Mesh heater

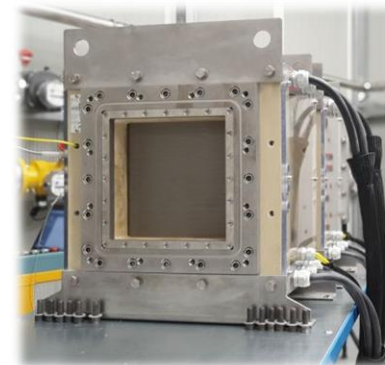

Water-cooled components for combustion testing

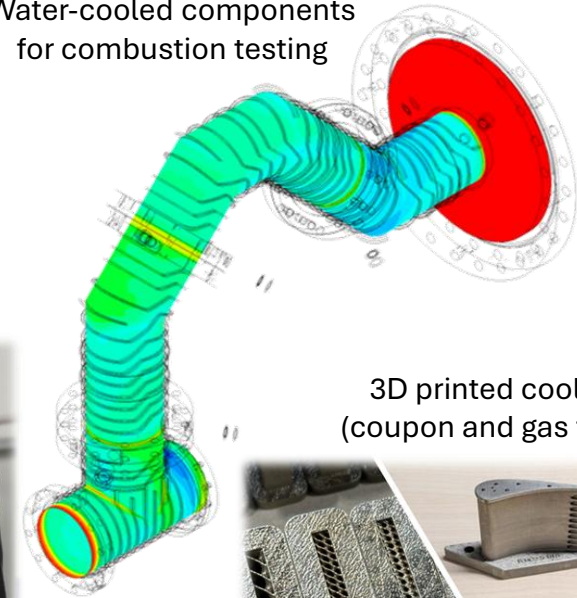

3D printed cooling systems (coupon and gas turbine vanes)



Vessel+deflector of GT exhaust

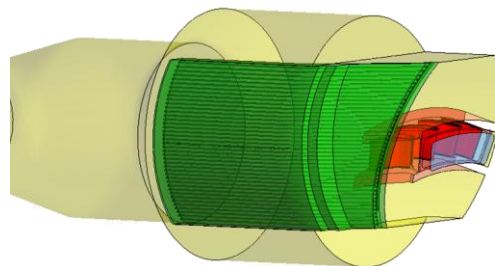

Temperature/emissions rakes

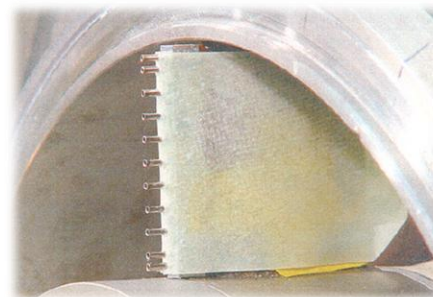

Full annular combustion test campaign



Impingement heat transfer rig

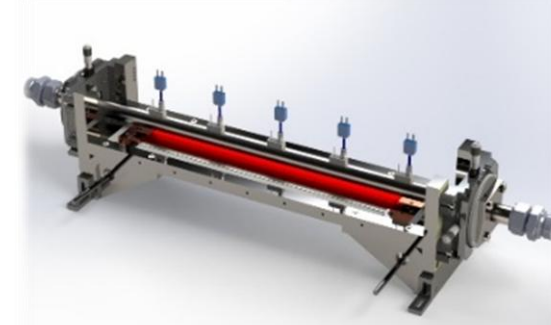

Copyright 2026
Ergon Research SRL.
All rights reserved.

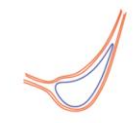

SIMULATIONS



EXPERIMENTS

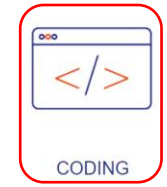

CODING



RESEARCH

Coding

Technical tools

Low time consuming
High reliability and robustness



Web apps

Standalone and web application
Authentication systems

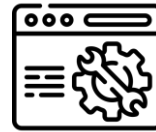

Data management

Storage and versioning of data
Advanced search and query capabilities

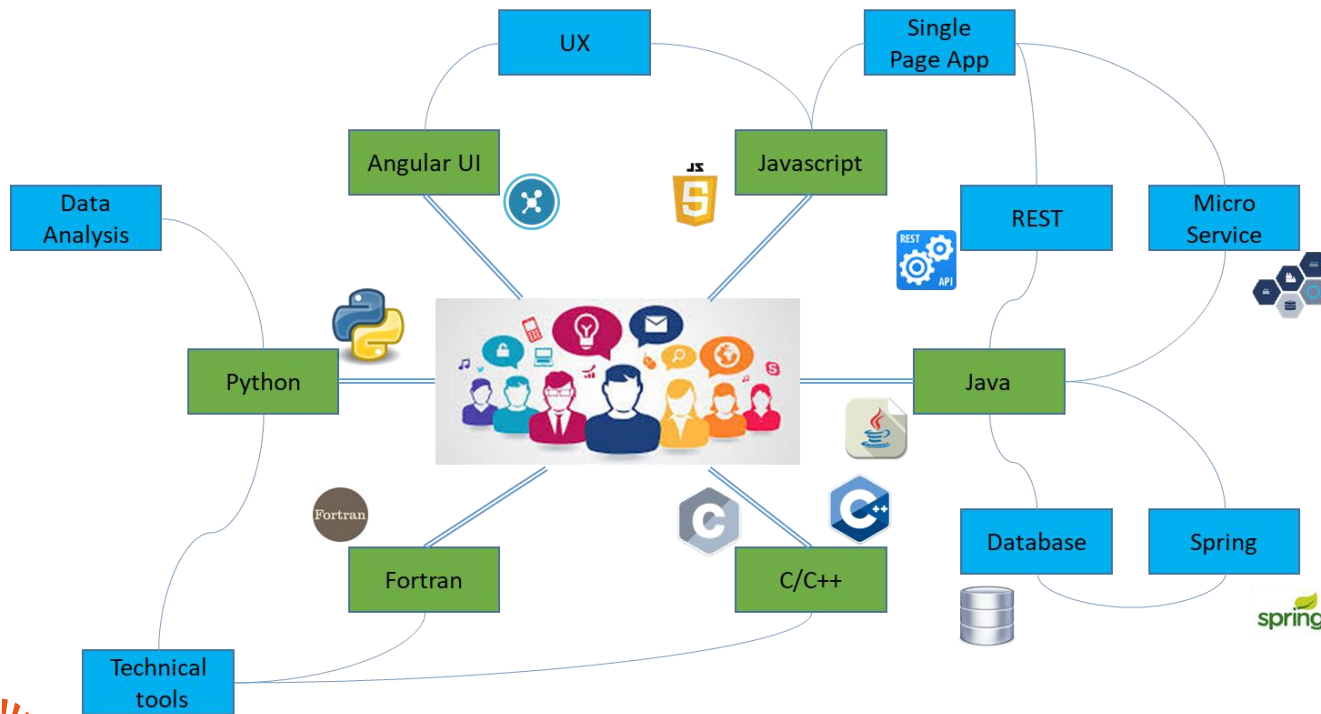

Bando Regione Toscana – POR CREO 2014-2020 – Azione 1.1.5 sub-azione a1) Bando 1 “Progetti strategici di ricerca e sviluppo”, D.D. n. 7165 del 24.05.2017 e ss.mm.ii

i-MAAT Mathematical Analytical Application Tool

Proprietary customizable Industry 4.0 tool for the formal **management of technical knowledge** and the implementation of **Model Based Enterprise**



Copyright 2026
Ergon Research SRL.
All rights reserved.

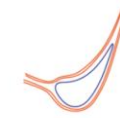

SIMULATIONS



EXPERIMENTS



CODING



RESEARCH

Ongoing EU-funded R&D&I projects

- **HYDEA** 2023-2027 – HYdrogen DEMonstrator for Aviation
 - Design of high-pressure combustion test rigs
- **HOPE** 2023-2027 – Hydrogen Optimised multi-fuel Propulsion system for clean and silent aircraft
 - Development of CFD models for multi-fuel (kero-H₂) and design of new combustion system
- **AMBER** 2023-2027 – InnovAtive DeMonstrator for hyBrid-Electric Regional Application
 - Design of innovative thermal management systems for fuel cells
- **TRIATHLON** 2024-2027 – Thermodynamics-dRiven control mAnagement of Hydrogen powered and electrified propuLsion for aviatiON
 - Studies on fuel cell system, thermal management solution enabled by additive manufacturing, hydrogen and air flow conditioning, whole powertrain static and dynamic modelling during the flight envelope
- **SONATA** 2025 – Sistemi di raffreddamentO in maNifattura AddiTiva per la propulsione innovativa
 - Numerical optimization and prototype realization of gas turbine cooling systems made in additive manufacturing
- **SILENT** 2023-2027 – Studies and pre-design of next-generation quiet hypersonic wind tunnel facilities for European strategic auTonomy
 - Full pre-design of a low-enthalpy Wind Tunnel and feasibility studies of a flight-enthalpy Wind Tunnel for hypersonic applications
- **DAMAGER** 2024-2028 – stuDY of Additive ManuFActuring for low-cost, low-observable, hiGHly-deployable, expendable/atritable tuRbojet engines
 - Design, metallic/ceramic additive manufacturing and testing of compressors, recuperators, combustors, turbines and nozzles for high-efficiency and low-cost small turbojet for expendable/atritable UAVs

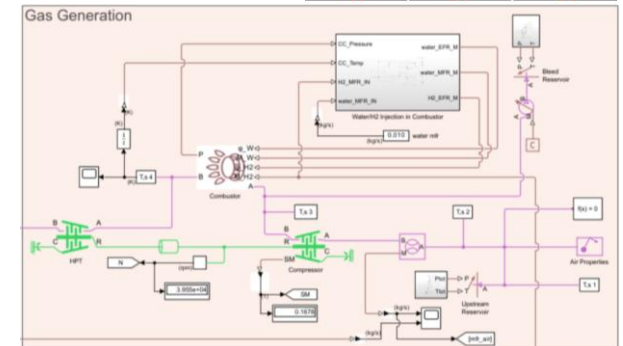
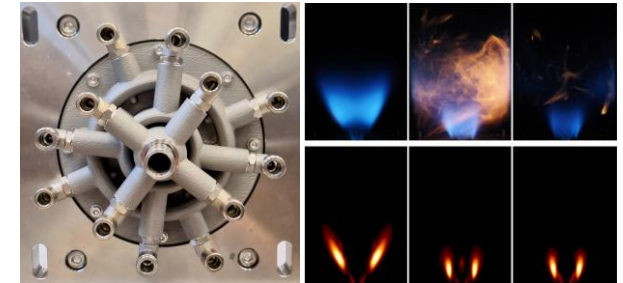



SIMULATIONS



EXPERIMENTS



CODING



RESEARCH

Past EU-funded R&D&I projects

- **NEWAC** 2006-2011 – NEW Aero Engine Core Concepts – EU FP7
 - Design and development of experimental test rig components for combustor cooling systems
- **LEMCOTEC** 2011-2015 – Low Emissions Core-Engine Technologies – EU FP7
 - Design and development of experimental test rig components for combustor cooling systems
- **IMPACT-AE** 2011-2015 – Intelligent Design Methodologies for Low Pollutant Combustors for Aero-Engines – EU FP7
 - Development of a high-pressure and high-temperature test rig for aeronautic combustor testing
- **ATENE** 2013-2015 – Advanced Technologies for ENergy Efficiency - FAR FAS
 - Development of technologies for energy efficiency in the turbomachinery field
- **ENOVAL** 2013-2017 – Engine Module Validators – EU FP7
 - Design of a gearbox test rig for the investigation of heat rejection and lubrication
 - Development of dedicated numerical tools to predict windage and heat rejection
- **RI.CO.EM** 2015-2016 – POR FESR 2014-2020
 - Reactive CFD simulations to improve a furnace to sinter alumina spheres

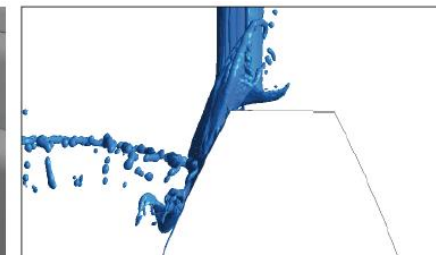
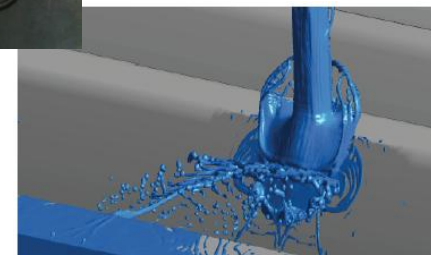
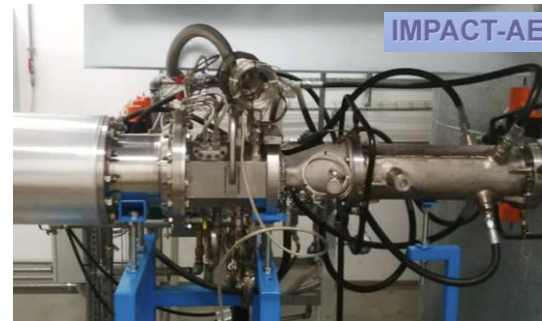
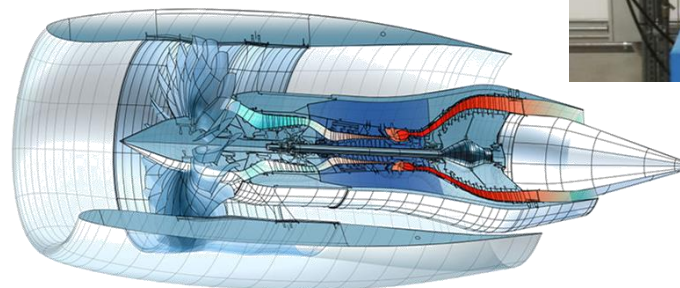
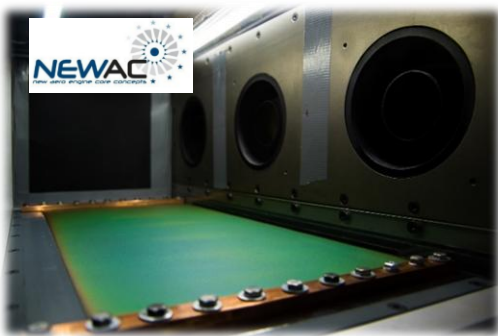

Copyright 2026
Ergon Research SRL.
All rights reserved.



SIMULATIONS



EXPERIMENTS



CODING



RESEARCH

Past EU-funded R&D&I projects

- **i-MAAT**: 2017-2018 – Mathematical Analytical Application Tool – POR FESR 2014-2020
 - Development of software platform that streamlines the knowledge-based design process orchestrating the data exchange between different tools (coordinator Baker Hughes)
- **S-TECH** 2017-2019 – Smart Turbine tEChnologies – FAR FAS
 - Design of high-pressure combustion test rig
- **ACCENTO** 2019-2022 – Active Clearance Control dEsign and characterization – CleanSky 2
 - Coordination, test rig design, commissioning and operation ACC system design tools development
- **HPacC-WIND** 2022-2023 – High-Performance air-cooled Condenser in any WIND conditions – ff4EuroHPC
 - Coordination, CFD simulations and digital twin creation of air-cooled condensers
- **FULCRUMS** 2024-2025 – high-Fidelity cfd simULations of non-Conventional hydRogen combUstion systemM for aeronauticS – EuroHPC
 - Coordinator, use HPC to simulate H₂ aeronautical combustion systems
- **HPCC4SCO2** 2025 - High Performance Centrifugal Compressor for Supercritical CO2
 - HPC simulations for hi-fi design of sCO₂ centrifugal compressors



i-MAAT
Mathematical Analytical Application Tool

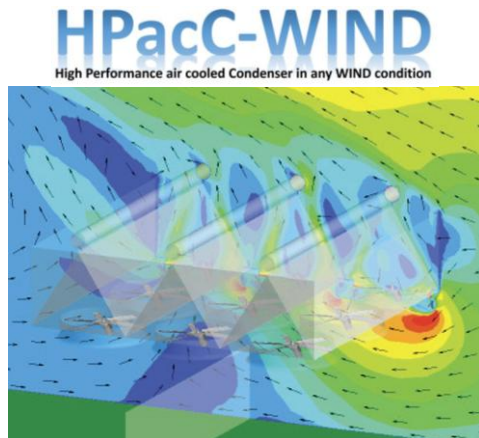

HPacC-WIND
High Performance air cooled Condenser in any WIND condition

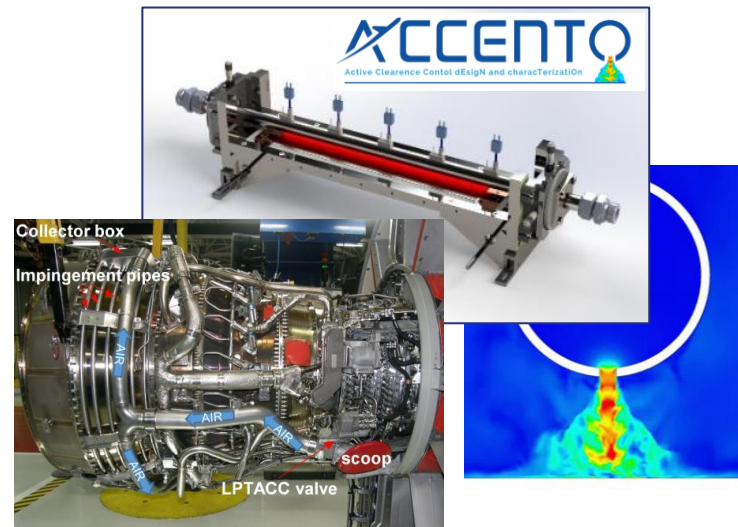

ACCENTO
Active Clearance Control dEsign and characterization

FULCRUMS

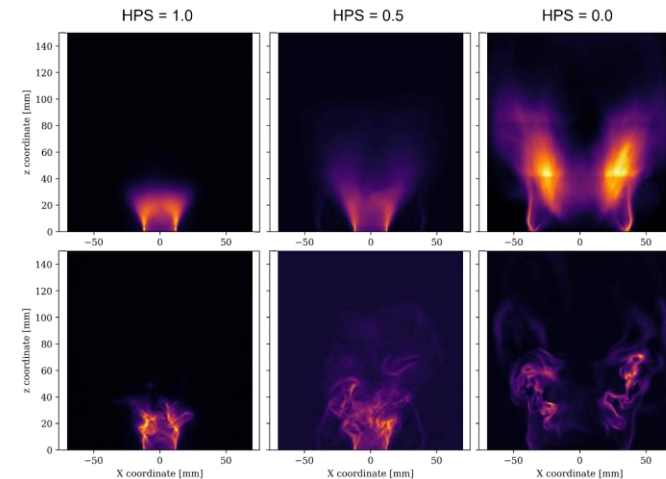

Copyright 2026
Ergon Research SRL.
All rights reserved.

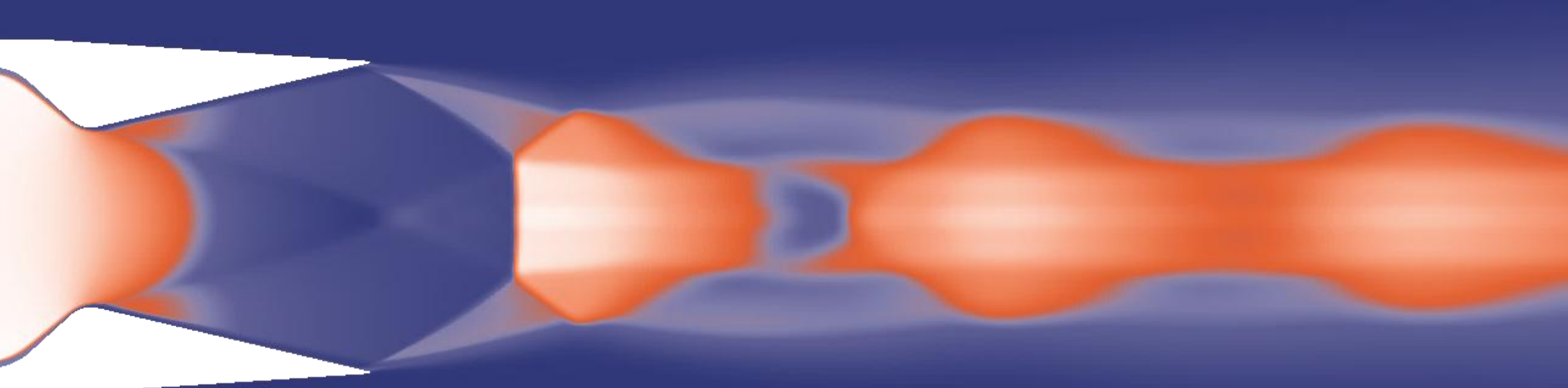

From advanced cooling to hypersonic technologies,
we craft solutions for complex challenges.

Blending precision with adaptability,
we turn problems into seamless performance.

Where innovation meets efficiency,
we make engineering flow smoothly.





 Via G. Campani 50, 50127 Firenze

 Tel - (+39) 055 5391855

 Web - www.ergonresearch.it

 Email - info@ergonresearch.it

 P.IVA - C.F. 05877940485