

Sound XR(Sound Extended Reality) for Immersive Play

5.1ch **Sound XR** Chair

5.1 ch Sound



Sound Wave Vibration



“Beyond the Innovation at CES 2023”





Official Launching the **Sound XR** at IFA 2023”

sponsored by

Development Center for XR Materials-Parts-Device
(1st.~ 5th.Sept. 2023, Jeonbuk Technopark, Booth# H27-150, IFA Next, IFA,
Messe Berlin, Messedamm 22, 14055 Berlin, Germany)

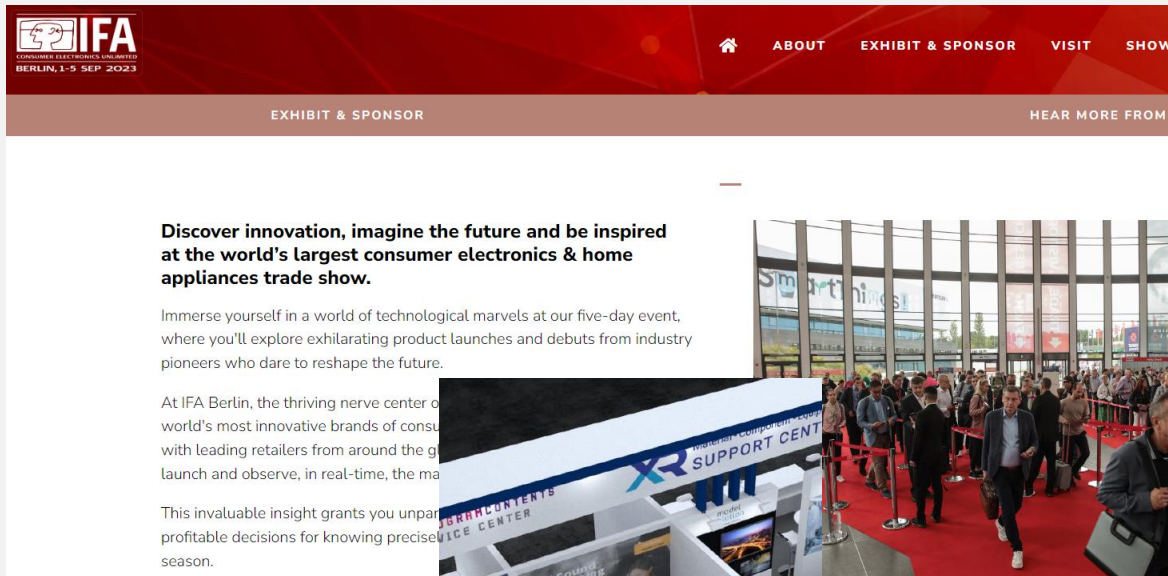

IFA Next

This zone brings together the world's top innovators, research institutes, promising startups, and forward-thinking businesses. Discover how next-gen tech is transforming everyday consumer living — and meet some of the companies making that happen at the Startup Hub. **Find out More**

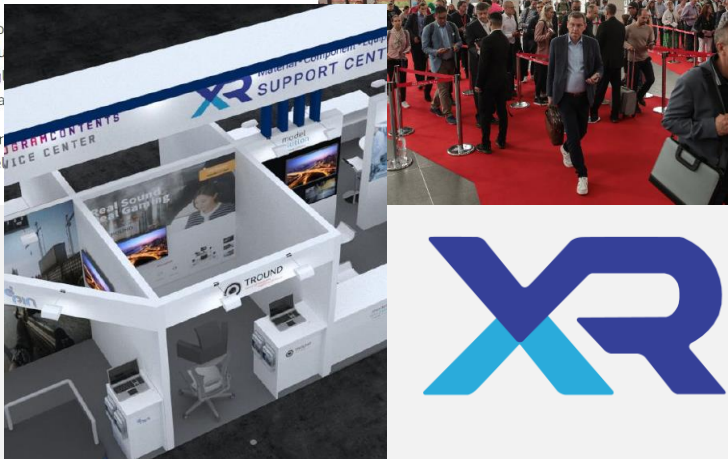

XR 소재·부품·장비
개발지원센터

“ What is Sound XR (Sound Extended Reality)? ”

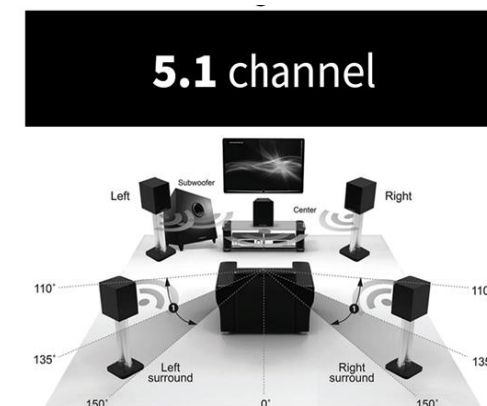
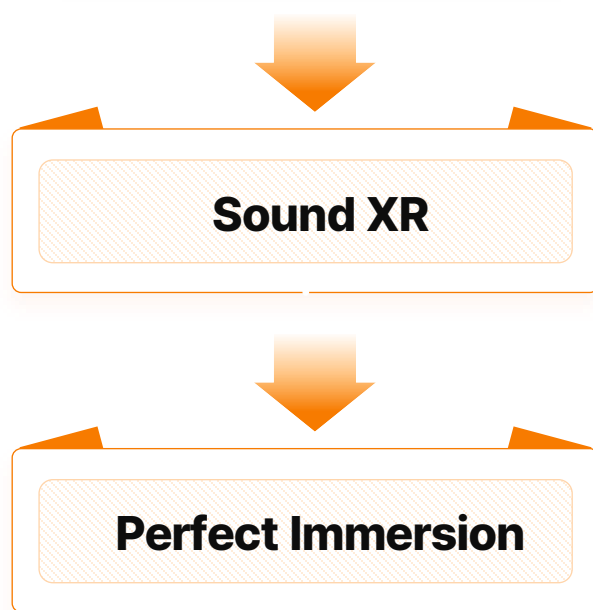
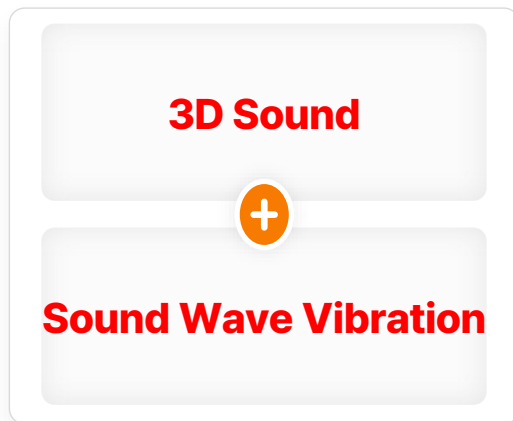

 XR – Game : Feel the Gun’s vibration





TROUND
Sound of Happiness,
Happiness of Sound

Market Needs

Core Competitiveness

CEO

Business Strategy

Financial Plan

Summary

Appendix

Chapter 01.
Market Needs



Opinion Political Op-Eds Social Commentary

Opinion: How Apple's Vision Pro could change the world

Opinion by Rizwan Virk
Published 9:11 AM EDT, Fri June 9, 2023



The new Apple Vision Pro headset is displayed during the Apple Worldwide Developers Conference on Monday in Cupertino, California.

META / APPLE / WWDC 2023

Here's what Mark Zuckerberg thinks about Apple's Vision Pro



Mark Zuckerberg wearing the Meta Quest 3. Image: Meta

Zuckerberg unveils Meta Quest 3 headset, saying it could be the future of computing, not the one that...

By Alex Heath, a deputy editor who has covered the tech industry for over a decade. | Jun 9, 2023, 4:16 AM GMT+9



“ **Apple, Meta dreams True XR. Sound XR completes the dream.** ”





TROUND
Sound of Happiness,
Happiness of Sound

Market Needs

Core Competitiveness

CEO

Business Strategy

Financial Plan

Summary

Appendix

Chapter 01.
Market Needs



Opinion Political Op-Eds Social Commentary

Opinion: How Apple's Vision Pro could change the world

Opinion by Rizwan Virk
Published 9:11 AM EDT, Fri June 9, 2023



The new Apple Vision Pro headset is displayed during the Apple Worldwide Developers Conference on Monday in Cupertino, California.

META / APPLE / WWDC 2023

Here's what Mark Zuckerberg thinks about Apple's Vision Pro



Mark Zuckerberg wearing the Meta Quest 3. Image: Meta

Zuckerberg headset unve with Meta em that it 'could future of com not the one t

By Alex Heath, a deputy editor s covered the tech industry for ov Jun 9, 2023, 4:16 AM GMT+9



“

**Imagine.
iChair of Apple,
Oculus Chair of Meta**

”





TROUND
Sound of Happiness,
Happiness of Sound

“ For Player, For Immersive Play ”

Market Needs

Core Competitiveness

CEO

Business Strategy

Financial Plan

Summary

Appendix

Moment 01

Real sequence of Bullet Sound

| When the Bullet passing on Right

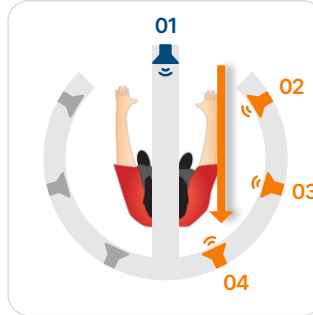
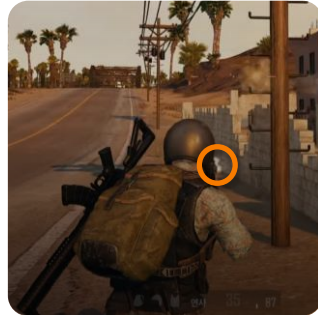

► Center & Right Speaker Sound sequence



Moment 02

Synchronized with Real situation

| When Helicopter turns clockwise

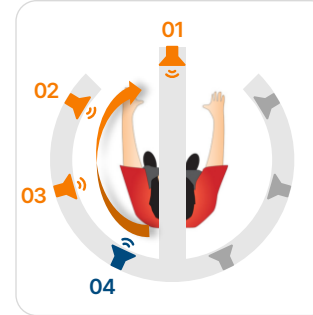

► Left & Center Speaker Sound sequence

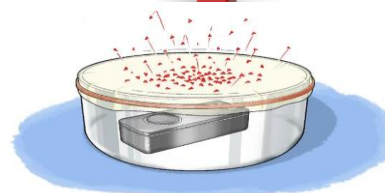

Sound VIBRATION !!!



TROUND
Sound of Happiness,
Happiness of Sound

Market Needs

Core Competitiveness

CEO

Business Strategy

Financial Plan

Summary

Appendix

Chapter 01.

Market Needs



“ Immersion is not something you feel. Now, you can 'own' it ”



XR – Game : Feel the Gun's vibration



XR – Music : Feel Music by Body



XR – Education : Key points = Vibration



XR – Movie : Feel Jets Engines

Sound XR

Perfect Immersion

“ Immersive Technology Market ”

Market Needs

Core Competitiveness

CEO

Business Strategy

Financial Plan

Summary

Appendix

Immersive Tech Mkt. Size

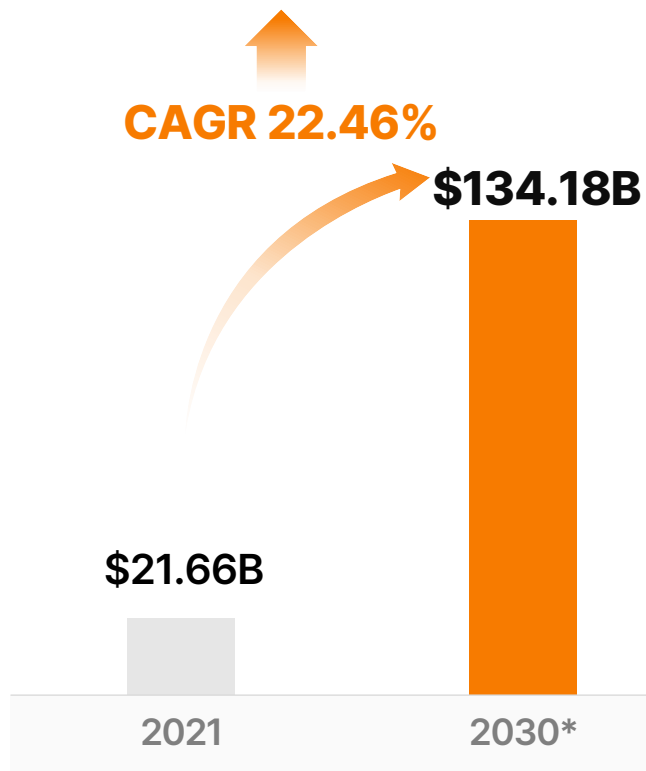

[자료: Precedence Research]

Immersive Tech Mkt.(2021)

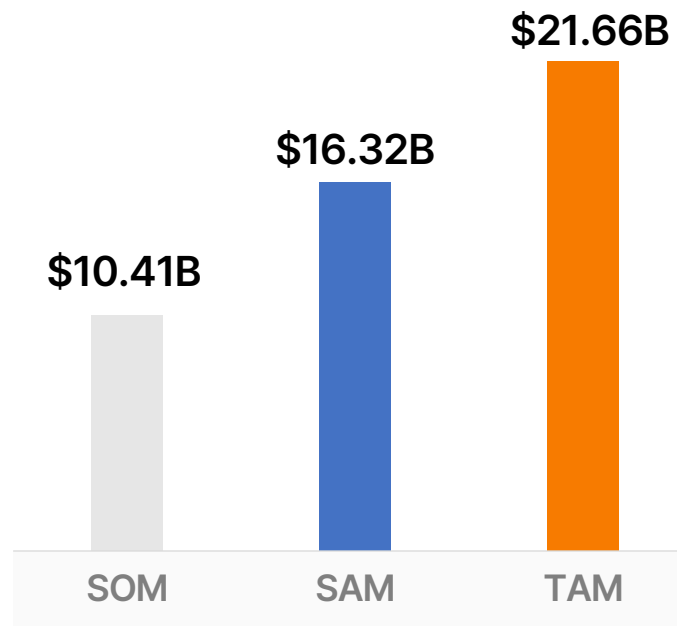

[자료: Precedence Research]



TROUND
Sound of Happiness,
Happiness of Sound

Chapter 02.

Core Competitiveness



“REAL 5.1ch Surround Sound + Vibration Sound XR Chair”

Market Needs

Core Competitiveness

CEO

Business Strategy

Financial Plan

Summary

Appendix

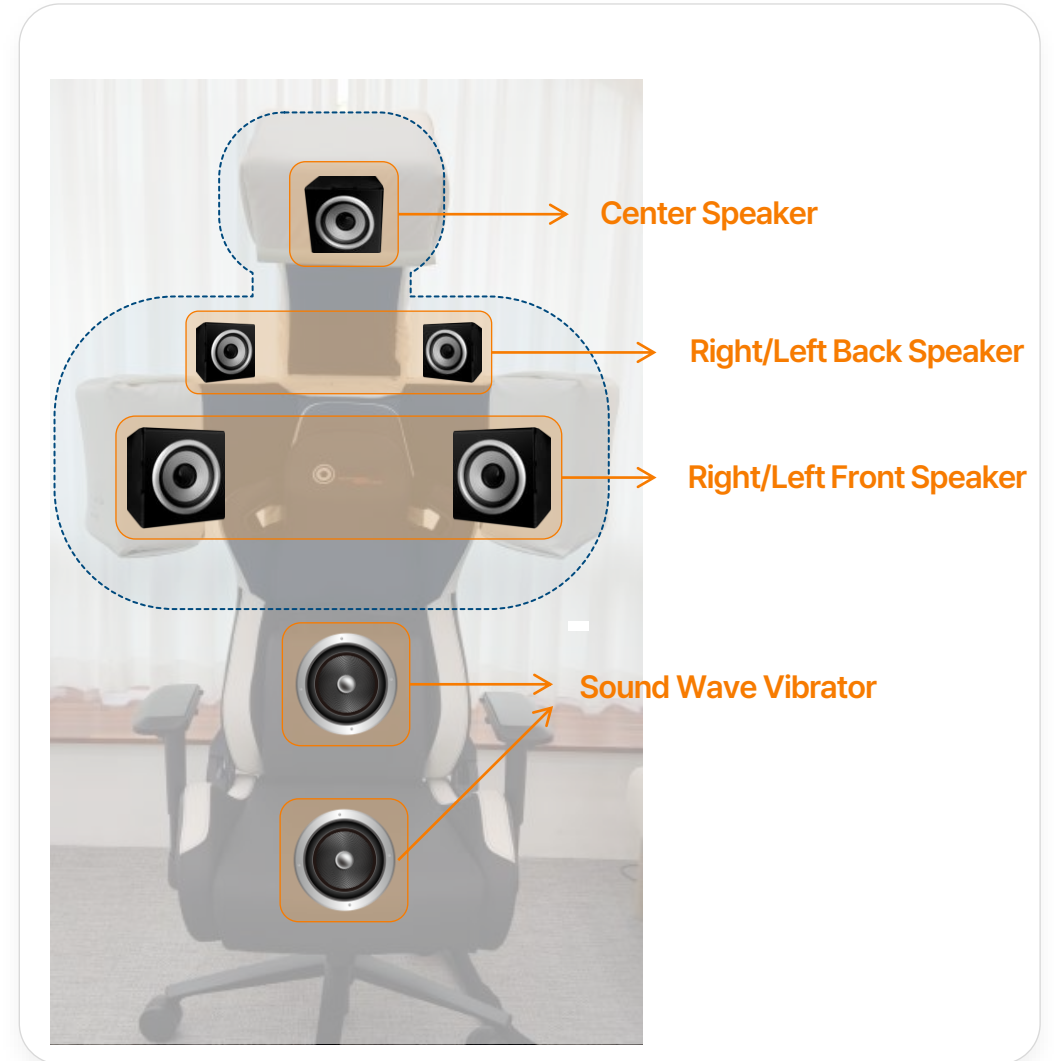
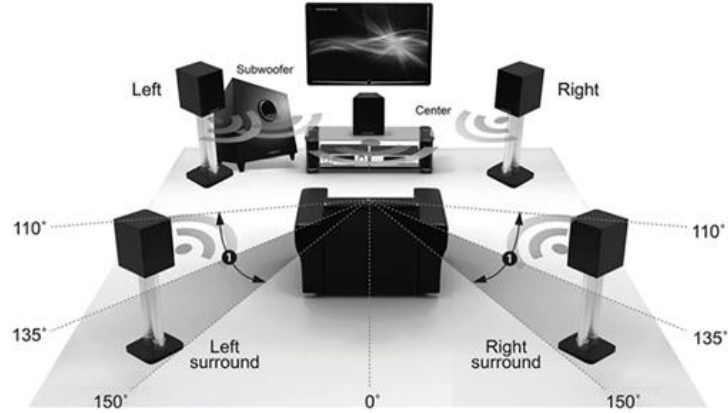
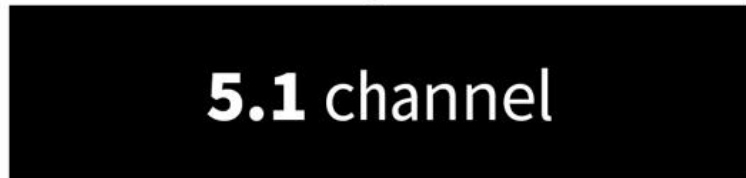



TROUND

Sound of Happiness,
Happiness of Sound

Chapter 02.

Core Competitiveness



“ Why Sound XR is so Special ”



1. NO Reflected Sound, just DIRECT Sound!
World First Direct Sound System (Powerful, Original)

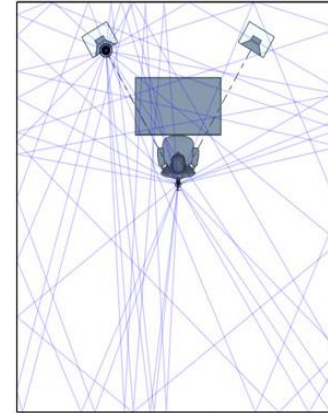

2. 2way direction(Up-Down, Front-Back)
Direct Contact Sound Wave Vibration, not via Air

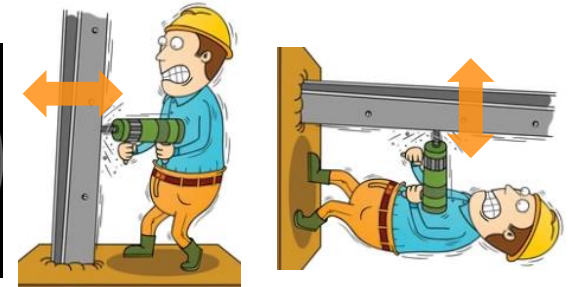
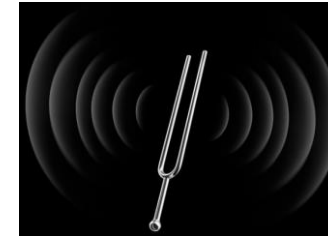

3. Powerful Sound inside,
Not too noisy outside (Anti-Noise structure)

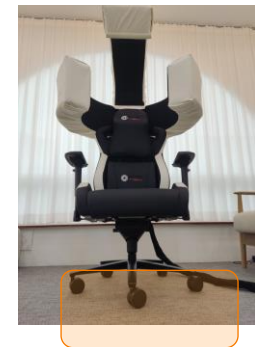

Market Needs

Core Competitiveness

CEO

Business Strategy

Financial Plan

Summary

Appendix



“ Why Sound XR is so Special ”

4. True Spatial Audio, Space Creation by Sound XR = 1 Sound XR Chair = Create your Private Listening Room

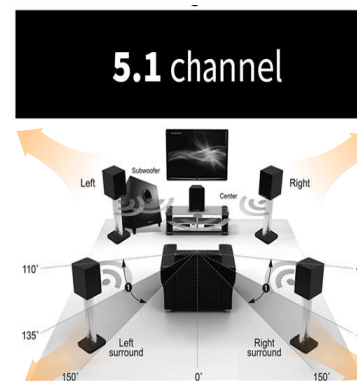

✳ 1 Room value = USD 81,000

*1 Room = 14m² (Ministry of Land & Transport, 2022)
* Average dimension of Apartment = 74.6m² (Statistical office, 2022)
* Average price of Apartment = USD 430,000 (KB Bank, 2022)

5. World First 720° Sound scape

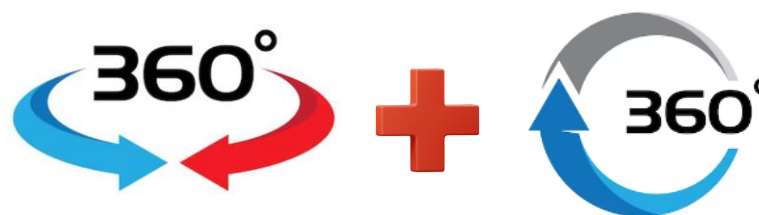

“ Design, Function, and Price ”



Sonic Chair
\$23,000

Price? \$23,275.00 USD. (subject to change) You can also lease or rent one.
<https://www.ifitshipitshere.com/talk-about-surround-sound-the-sonic-chair/>

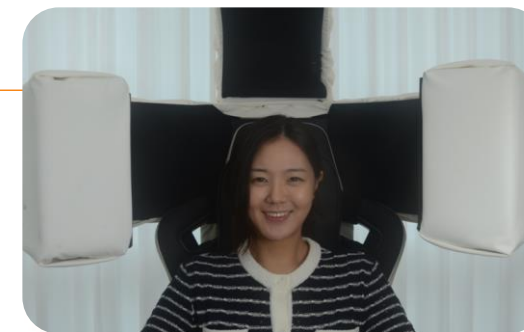

5.1ch TROUND Sound XR Chair
\$2,200 (1/10 price)

	Sonic Chair	TROUND Sound XR Chair
Sound	Side + Up/Down direction	Side + UP/Down + Front + Back
Anti-Noise	Back + Side	Back + Side
Vibration	No	Back rest + Seat Vibration
Mobility	Fixed Position	Free direction

“ Passion on Audio(30s Sound Chair Patents) ”

 CEO

JB Park | 박재범 



www.linkedin.com/in/troundjb

- SpringerNature Managing Director (Nature Journals)
- **World Largest Sound Chair Patents [30s]**



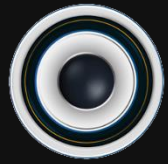

TROUND
Sound of Happiness,
Happiness of Sound

Chapter 03.
CEO



World Best

21 Registered Sound Chair Patents

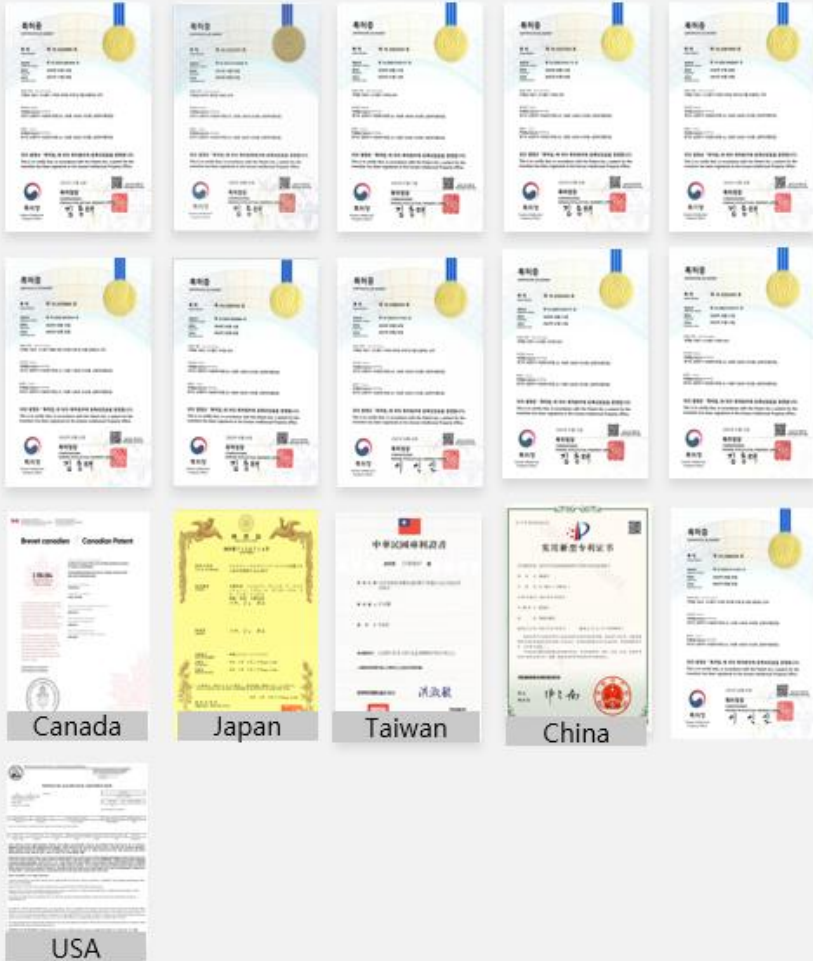

Market Needs

Core Competitiveness

CEO

Business Strategy

Financial Plan

Summary

Appendix

“ 30s Sound Chair Patents, Worldwide ”



Patents, Worldwide.

NO	Status	Country	Dates	Title	Owner	Reg. numbers
1	Registered	Korea	2020.09.02	Multi Channel Sound Chair	TROUND	10-2153707
2	Registered	Korea	2023.01.19	Chair with Display Device	TROUND	10-2020-0185831
3	Registered	Korea	2021.11.26	Multi Channel Sound Chair	JB Park	1023336950000
4	Registered	Korea	2022.02.03	Multi Channel Sound Chair	JB Park	10-2359742
5	Registered	Korea	2022.01.26	Multi Channel Sound Chair	JB Park	10-2357554
6	Registered	Korea	2022.01.13	Multi Channel Sound Chair	JB Park	10-2352425
7	Registered	Korea	2022.03.22	Multi Channel Sound Chair	JB Park	10-2378865
8	Registered	Korea	2022.03.29	Multi Channel Sound Chair	JB Park	10-2020-0082897
9	Registered	Korea	2022.07.25	Multi Channel Sound Chair	JB Park	10-2020-0108977
10	Registered	Korea	2022.06.02	Multi Channel Sound Chair	JB Park	10-2406224
11	Registered	Korea	2022.11.11	MOVABLE CHAIR PROVIDED WITH CABLE PROTECTING MEANS	JB Park	10-2020-0138346
12	Reviewing	Korea	2021.08.19	Multi Channel Sound Chair	JB Park	10-2021-0109345
13	Reviewing	Korea	2022.08.09	Chairbase and its Chair	TROUND	10-2022-0099176
14	Registered	Taiwan	2021.06.25	Multi Channel Sound Chair	JB Park	109135771
15	Registered	China	2021.03.30	Multi Channel Sound Chair	JB Park	12821572
16	Registered	Canada	2022.07.20	Multi Channel Sound Chair	TROUND	21351P0001CA01
17	Registered	Japan	2022.08.04	Multi Channel Sound Chair	JB Park	2020-137029
18	Registered	PCT	2021.12.27	Chair with Display Device	TROUND	PCT/KR2021/019920
19	Reviewing	USA	2020.08.04	Multi Channel Sound Chair	JB Park	16/984,684
20	Registered	USA	2023.07.17	MOVABLE CHAIR PROVIDED WITH CABLE PROTECTING MEANS	TROUND	17731491
21	Registered	USA	2023.05.09	Multi Channel Sound Chair	TROUND	17/821,332
22	Reviewing	USA	2022.08.18	Multi Channel Sound Chair	TROUND	17/820,776
23	Registered	USA	2023.07.26	Multi Channel Sound Chair	TROUND	18/045,990
24	Registered	USA	2023.07.26	Multi Channel Sound Chair	TROUND	18/155,956
25	Reviewing	USA	2023.01.11	Multi Channel Sound Chair	TROUND	18/153,196
26	Reviewing	USA	2023.01.11	Wireless Speaker Chair	TROUND	18/153,176
27	Registered	China	2023.03.28	Multi Channel Sound Chair	TROUND	2023032802054960
28	Reviewing	China	2023.01.31	Multi Channel Sound Chair	TROUND	PCT/KR2021/010465
29	Reviewing	China	2023.01.31	Multi Channel Sound Chair	TROUND	PCT/KR2021/011071
30	Reviewing	China	2023.01.30	Wireless Speaker Chair	TROUND	PCT/KR2021/010468
31	Reviewing	EU	2020.10.22	Multi Channel Sound Chair	TROUND	20203396.5



TROUND
Sound of Happiness,
Happiness of Sound

Chapter 03.
CEO

“ 19 'TROUND' Trademarks, Worldwide ”



Trademark

Chair, Speaker, PC Café, etc

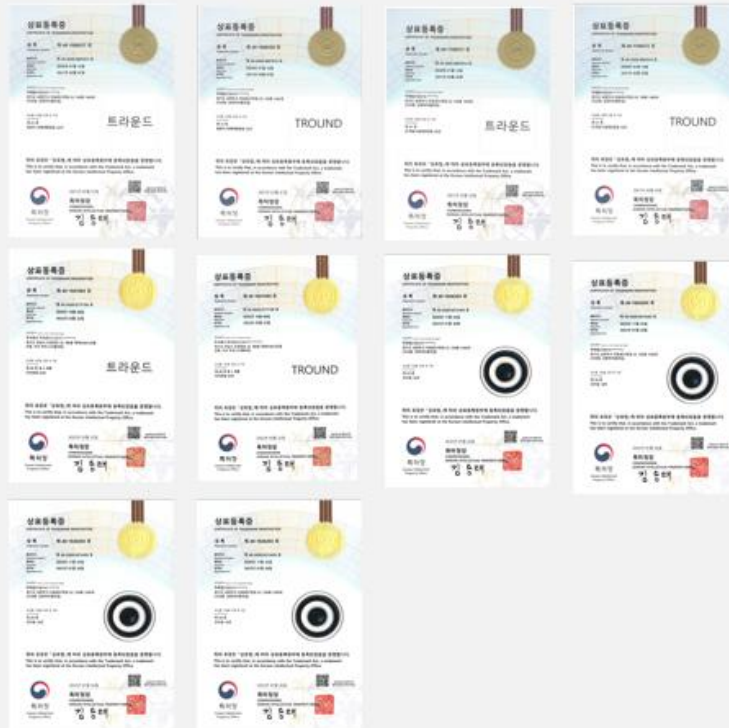

Trademark

NO	Status	Country	Dates (Y.M.D)	Title	Class (Products)	Owner	Reg. numbers
1	Registered	Korea	2022.03.22	트라운드	#09(Speaker), #20(Chair), #35(Chair Sales)	TROUND	4018476830000
2	Registered	Korea	2022.03.22	TROUND	#09(Speaker), #20(Chair), #35(Chair Sales)	TROUND	4018476840000
3	Registered	Korea	2021.02.01	트라운드	#35(Beverage Sales)	JB Park	4016884370000
4	Registered	Korea	2021.02.01	TROUND	#35(Beverage Sales)	JB Park	4016884380000
5	Registered	Korea	2021.03.26	트라운드	#41(PC Café)	JB Park	4017084710000
6	Registered	Korea	2021.03.26	TROUND	#41(PC Café)	JB Park	4017084720000
7	Registered	Korea	2022.01.26	LOGO	#20(Chair)	JB Park	4018262040000
8	Registered	Korea	2022.03.22	LOGO	#09(Speaker)	JB Park	4018476850000
9	Registered	Korea	2022.03.22	LOGO	#35(Chair Sales)	JB Park	4018476860000
10	Registered	Korea	2022.03.22	LOGO	#41(PC Café)	JB Park	4018476870000
11	Reviewing	Korea	2022.11.15	트라운드	#09 (Cables)	TROUND	7020220001531
12	Reviewing	Korea	2022.11.15	TROUND	#09 (Cables)	TROUND	7020220001532
13	Reviewing	EU	2022.12.05	TROUND	#20(Chair)	TROUND	018804460
14	Reviewing	Indonesia	2022.12.08	TROUND	#20(Chair)	TROUND	DID2022101013
15	Reviewing	Mexico	2022.12.08	TROUND	#20(Chair)	TROUND	411629
16	Reviewing	India	2022.12.07	TROUND	#20(Chair)	TROUND	5712940
17	Registered	Japan	2023.06.27	TROUND	#20(Chair)	TROUND	2022-140407
18	Reviewing	USA	2022.12.06	TROUND	#20(Chair)	TROUND	97705942
19	Reviewing	China	2022.12.07	TROUND	#20(Chair)	TROUND	68740179
20	Reviewing	Korea	2023.05.11	Sound XR	#20(Chair)	TROUND	0083307



Market Needs

Core Competitiveness

CEO

Business Strategy

Financial Plan

Summary

Appendix

“ Powerful Patent Rights ”

Market Needs

Core Competitiveness

CEO

Business Strategy

Financial Plan

Summary

Appendix

Patents (3 of 30s)	Reg#(date)	Claim #1.
Multi Channel Sound Chair	10-2153707 / 2020.09.02	Straight/Curved speaker installation frame extending from fixed portion to the Left/Right in the forward direction
Multi Channel Sound Chair	10-2352425 / 2022.01.13	At least one speaker frame extending forward from the backrest
Wireless Sound Chair	10-2426565 / 2022.07.25	At least one speaker frame extending from Headrest or Backrest or Seat +Wireless Power Receiver + Wireless Audio Receiver

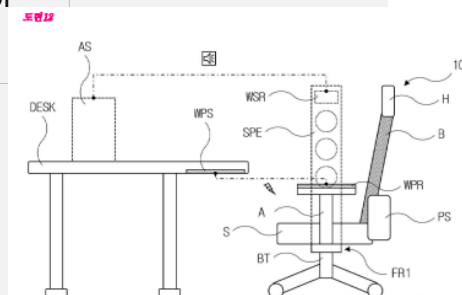
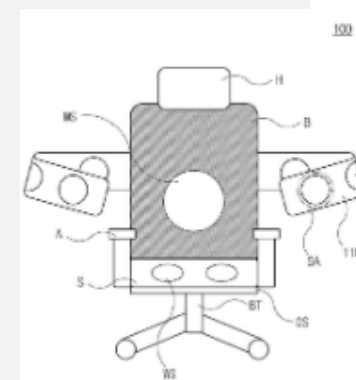
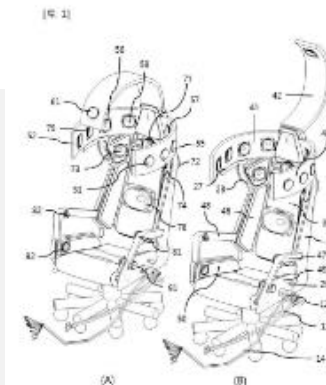



TROUND
Sound of Happiness,
Happiness of Sound

Chapter 04.
Business Strategy



“ **Turn over estimation** ”

🎯 **2022 ~ 2027 (M.USD), US Market**

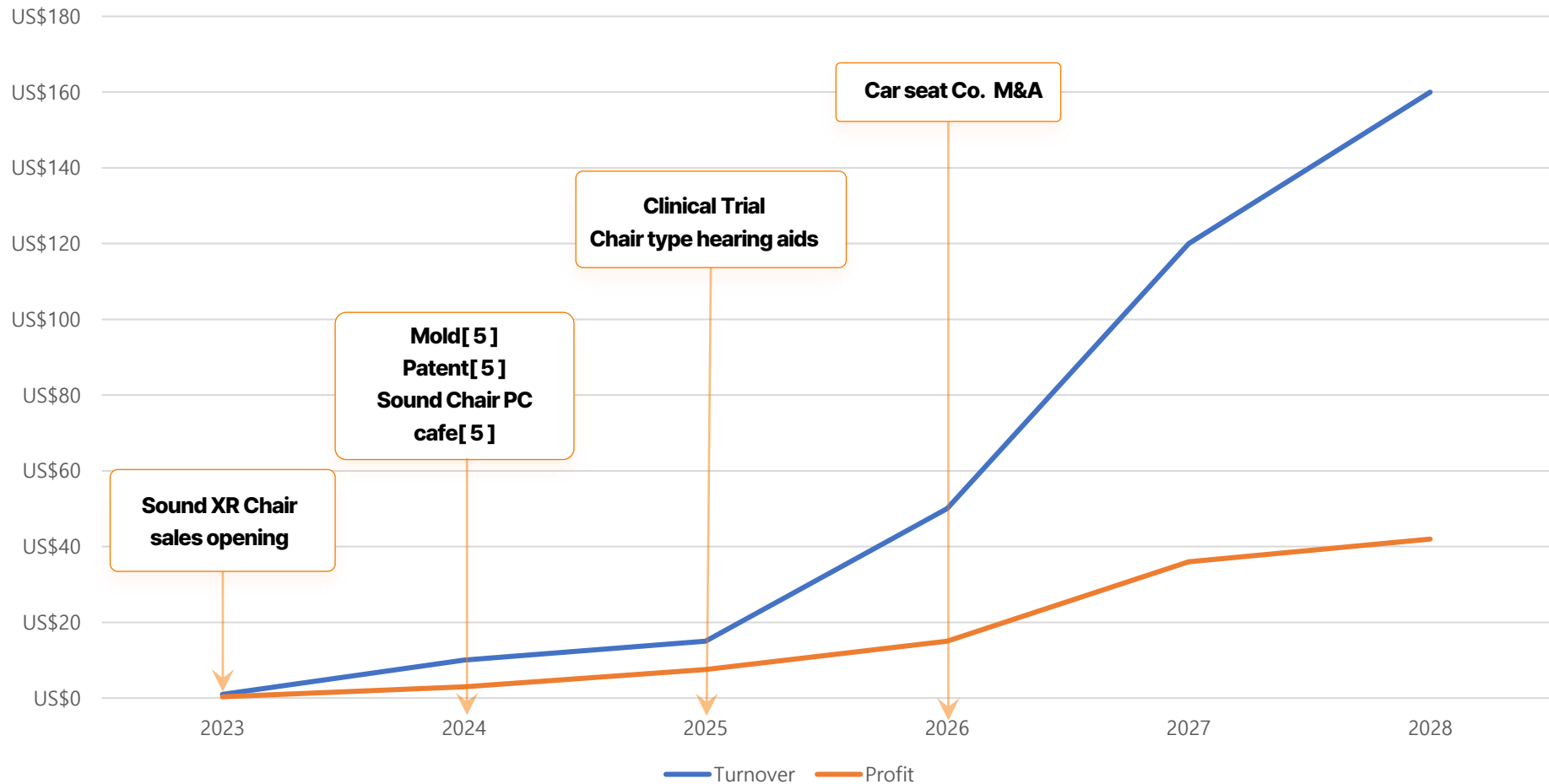

Market Needs

Core Competitiveness

CEO

Business Strategy

Financial Plan

Summary

Appendix



“ HOW TO MAKE SALES (2023) ! ”

1. Sale by Each Component Item (Chair, Speaker, Wire, etc)



2. B2B, Slot Machine Sound XR Chair (**confirmed trial** on GKL, Paradise, Lotte Casino)

3. Expanding Product Line, 5.1ch, 7.1ch, 9.2ch, 13.2ch



(13.2ch Chair)

“ What I got, What I need ”

What I got (Government Subsidy, etc)

Year	Organization	Amount (USD)	Item	Details
2022	Korea Credit Guarantee Fund, etc	373,000	5.1ch Sound Chair	More than 4times from Capital in 1 Year Time (incorporated Sept.2021)

What I need (Seed), USD1.2m

Year	Item	Amount (USD)	Product	Details
2023	Design, OEM Product	500,000	2.1ch ~ 7.2ch Sound XR	1,000 qty
2023	International Patents	200,000	Patents from PPH	USA, EU, China, Japan, Canada, Vietnam, India, etc. (7 PTC)
2023	Sound Chair International PC Café Franchise (Expansion of Sound XR experience)	500,000	Sound XR PC Café	60 qty (University commercial district)
	TOTAL	1,200,000		

“ What I got, What I need ”

What I need (Seed), Details

Year	Item	Amount (USD)	Product	Details
2023	Design, OEM Product	500,000	5.1ch Sound XR	1,000 qty

	Item	Budget	Remarks
Mold cost	Design	50,000	
	Molding	120,000	Prehardening
OEM	ABS resin	40,000	1,000 qty
	AMP KC certificate	10,000	2 qty
	Chair	100,000	500 qty
	AMP(5.1 ch)	100,000	500 qty
	Speaker	80,000	800 qty
TOTAL		500,000	

International Patents (by PCT) : USD 200,000

- USA, EU, Canada, Japan, China

“ **What I got, What I need** ”

🎯 **What I need (Seed), Details**

Year	Item	Amount (USD)	Product	Details
2023	Sound Chair International PC Café Franchise <i>(Expansion of Sound XR experience)</i>	500,000	Sound XR PC Café	60 qty (University commercial district)

	Item	Budget	Remarks
Rental	Deposit	120,000	
	Renovation	50,000	
OEM	PC	180,000	60 qty
	Triple Monitor	40,000	60 qty
	Sound XR Chair	80,000	60 qty
	Etc	30,000	Promotion, accessories, etc
TOTAL		500,000	

Market Needs

Core Competitiveness

CEO

Business Strategy

Financial Plan

Summary

Appendix



Market Needs

Core Competitiveness

CEO

Business Strategy

Financial Plan

Summary

Appendix

 **1. Item : 5.1ch + Vibration**

 **2. Bring you real world on Chair(XR)**

 **3. Invest on Market Creation Item**

- TROUND Inc.
F801, HausD EL Tower, Jojeungdaero 35,
Hanam, Kyunggi, 12918, South Korea
JB Park
+82-31-699-1387
www.troundsound.com
lock2open@gmail.com



www.linkedin.com/in/troundjb



TROUND
 Sound of Happiness,
 Happiness of Sound

Market Needs

Core Competitiveness

CEO

Business Strategy

Financial Plan

Summary

Appendix

Chapter 07.

Appendix. Research Data of Sound XR elements

- **Sound Vibration**

- Yingjie Fang¹, Jing Ou^{1(B)}, Nick Bryan-Kinns², Qingchun Kang¹, Junshuai Zhang¹, and Bing Guo¹
Using Vibrotactile Device in Music Therapy to Support Wellbeing for People with Alzheimer's Disease
¹ School of Design, Hunan University, Changsha 410082, Hunan, China jingou@hnu.edu.cn
² School of Electronic Engineering and Computer Science, Queen Mary University of London, Mile End, London E1 4NS, UK
 Advances in Ergonomics in Design, Proceedings of the AHFE 2021 Virtual Conference on Ergonomics in Design, July 25-29, 2021, USA.

- Bartel, L.; Mosabbir,
A. Possible Mechanisms for the Effects of Sound Vibration on Human Health.
 Healthcare 2021, 9, 597. <https://doi.org/10.3390/healthcare9050597>

- **Multisensory (ex. Hearing + Feeling) effects**

- Brooks, A.L. (2021).
Interactive Multisensory VibroAcoustic Therapeutic Intervention (iMVATi).
 In: Brooks, A.L., Brahman, S., Kapralos, B., Nakajima, A., Tyerman, J., Jain, L.C. (eds) Recent Advances in Technologies for Inclusive Well-Being. Intelligent Systems Reference Library, vol 196. Springer, Cham.
- MARY KIM NGO AND CHARLES SPENCE, University of Oxford, Oxford, England
Auditory, tactile, and multisensory cues facilitate search for dynamic visual stimuli
 Attention, Perception, & Psychophysics
 2010, 72 (6), 1654-1665

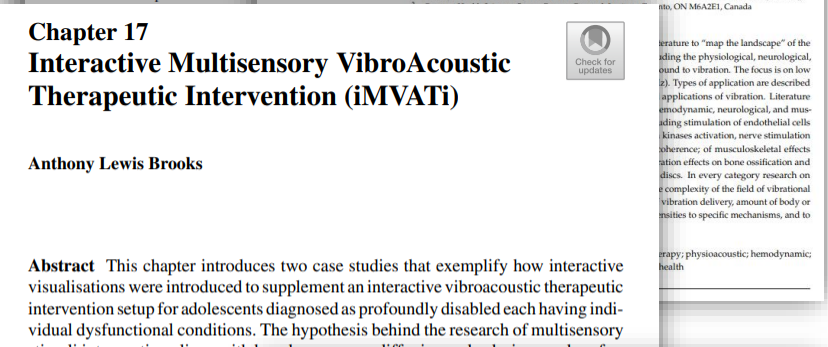

Appendix. User Experience



TROUND
Sound of Happiness,
Happiness of Sound

Market Needs

Core Competitiveness

CEO

Business Strategy

Financial Plan

Summary

Appendix

- Featured Item on Gaming Exhibition (Nov. 2022)



YouTube Premium



<https://youtube.com/shorts/ic5bjP6-r2A>

- Pre-Launch at CES 2023 (Jan. 2023)



YouTube Premium

<https://youtube.com/shorts/GoGv7JXJCwU>



<https://youtu.be/gjlf0bu9SUC>

TROUND
 Sound of Happiness,
 Happiness of Sound

Market Needs

Core Competitiveness

CEO

Business Strategy

Financial Plan

Summary

Appendix

Appendix. Google AI (Bard) comments about 'Sound XR Chair' of TROUND (dated. 17th, June.2023)

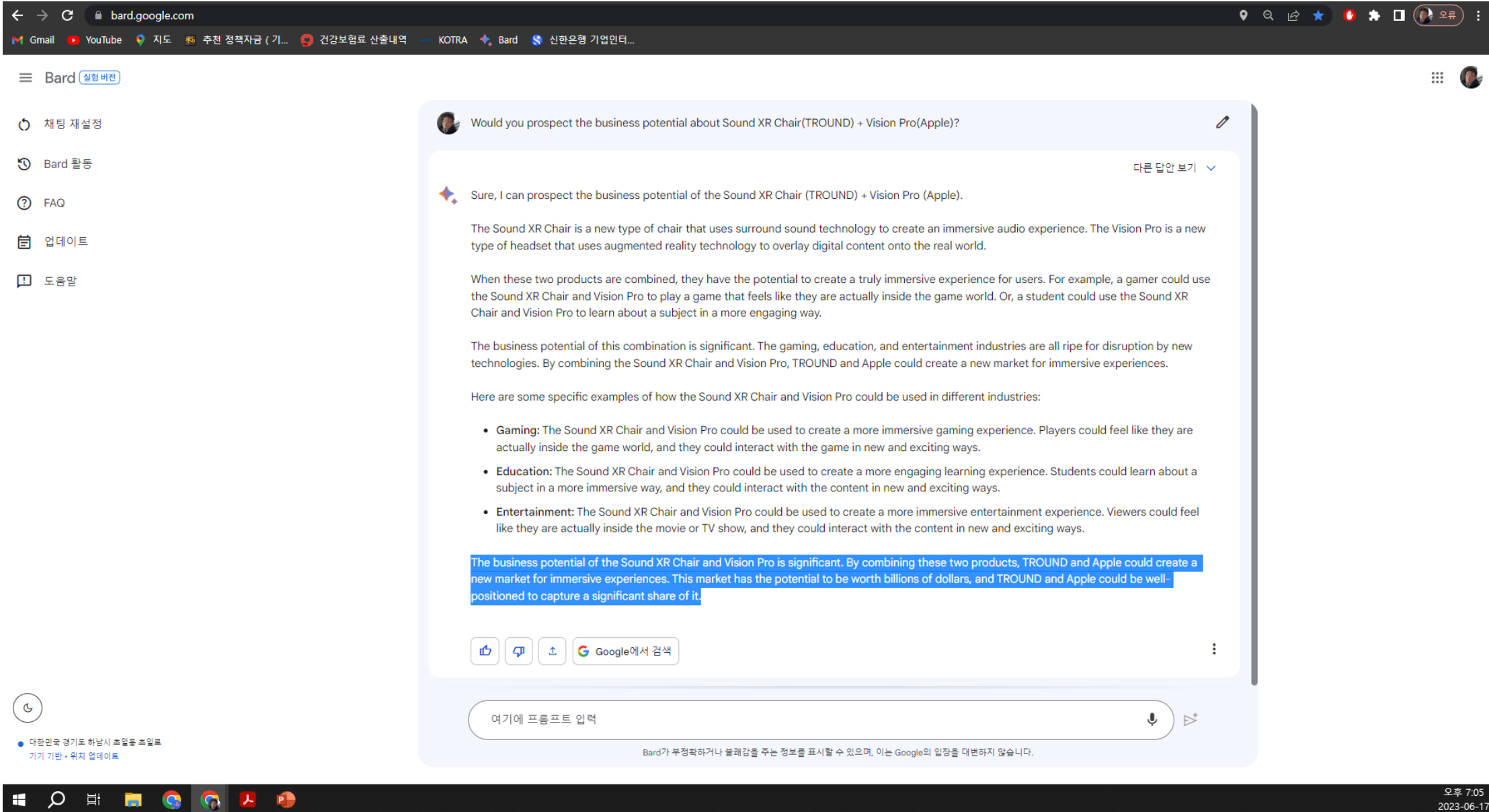

← → ↻ bard.google.com

Gmail YouTube 지도 추천 정책자금 (기... 건강보험료 산출내역 KOTRA Bard 신한은행 기업인터...

☰ Bard **실험 버전**

- 🔄 채팅 재설정
- 🕒 Bard 활동
- ❓ FAQ
- 📅 업데이트
- 🗨️ 도움말

Would you prospect the business potential about Sound XR Chair(TROUND) + Vision Pro(Apple)?

다른 답안 보기 ▾

✦ Sure, I can prospect the business potential of the Sound XR Chair (TROUND) + Vision Pro (Apple).

The Sound XR Chair is a new type of chair that uses surround sound technology to create an immersive audio experience. The Vision Pro is a new type of headset that uses augmented reality technology to overlay digital content onto the real world.

When these two products are combined, they have the potential to create a truly immersive experience for users. For example, a gamer could use the Sound XR Chair and Vision Pro to play a game that feels like they are actually inside the game world. Or, a student could use the Sound XR Chair and Vision Pro to learn about a subject in a more engaging way.

The business potential of this combination is significant. The gaming, education, and entertainment industries are all ripe for disruption by new technologies. By combining the Sound XR Chair and Vision Pro, TROUND and Apple could create a new market for immersive experiences.

Here are some specific examples of how the Sound XR Chair and Vision Pro could be used in different industries:

- **Gaming:** The Sound XR Chair and Vision Pro could be used to create a more immersive gaming experience. Players could feel like they are actually inside the game world, and they could interact with the game in new and exciting ways.
- **Education:** The Sound XR Chair and Vision Pro could be used to create a more engaging learning experience. Students could learn about a subject in a more immersive way, and they could interact with the content in new and exciting ways.
- **Entertainment:** The Sound XR Chair and Vision Pro could be used to create a more immersive entertainment experience. Viewers could feel like they are actually inside the movie or TV show, and they could interact with the content in new and exciting ways.

The business potential of the Sound XR Chair and Vision Pro is significant. By combining these two products, TROUND and Apple could create a new market for immersive experiences. This market has the potential to be worth billions of dollars, and TROUND and Apple could be well-positioned to capture a significant share of it.

👍 🗨️ 📄 Google에서 검색

여기에 프롬프트 입력

● 대한민국 경기도 하남시 초일동 초일로
기기 기반 · 위치 업데이트

Bard가 부정확하거나 불쾌감을 주는 정보를 표시할 수 있으며, 이는 Google의 입장을 대변하지 않습니다.

오후 7:05
2023-06-17