

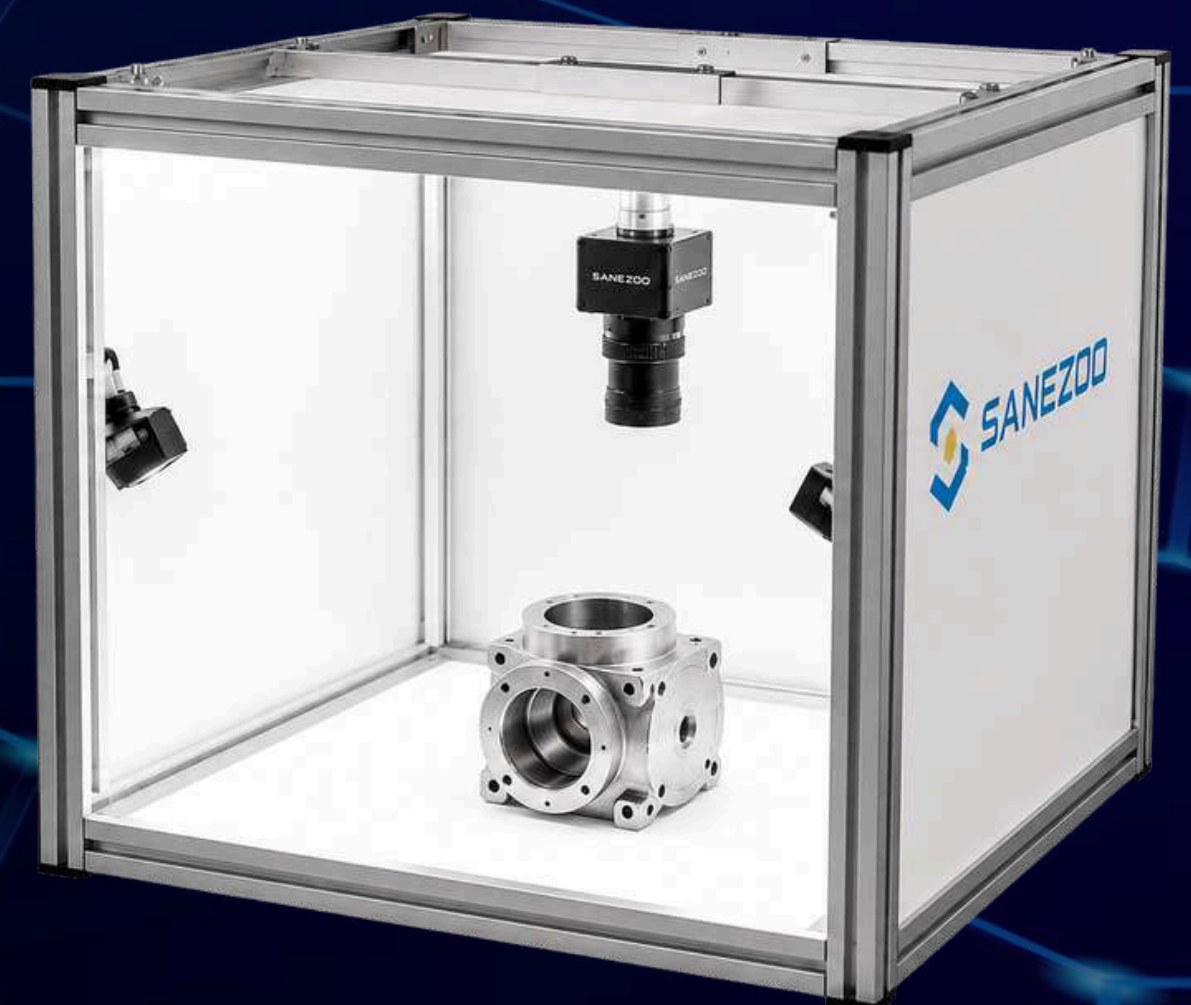

Sanezoo SmartCube

Fast Visual Quality Control

A Practical First Step Toward Automated Inspection



www.sanezoo.eu

When quality control needs to be fast, not complicated

A ready-to-deploy inspection workplace for manufacturers who need stable quality control results quickly

SANEZOO SmartCube combines everything needed for automated visual inspection in one controlled environment:

- camera
- lighting
- mechanical structure
- inspection software
- evaluation logic





The station arrives as a complete solution that can be configured for the required inspection task.



A complete inspection workplace in one station

Many inspection problems are urgent, but full line integration takes time, it requires mechanical changes and specialized engineering.

SANEZOO SmartCube offers a faster route: a standalone inspection workplace that can be deployed without rebuilding the production line. It can also serve as a first step toward a full-scale automation project.

-  Complete visual inspection setup
-  Controlled imaging environment
-  Standalone or semi-automatic operation
-  Configurable for different products
-  No complex production line integration



From manual checks to repeatable decisions

Manual visual inspection is flexible, but not always consistent. Different operators may judge the same part differently. Fatigue, lighting conditions, experience, and production pressure all affect the result.

SANEZOO SmartCube creates controlled inspection conditions and evaluates each product according to the same logic every time.



End-of-Line Quality Check

For deployment directly after production or assembly, where parts are checked before moving to the next process, packaging, or shipment

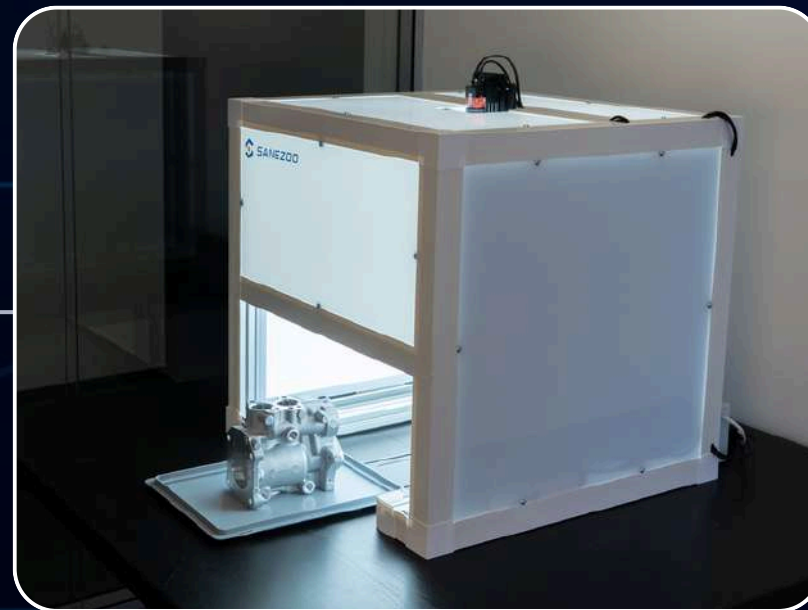

Quality Lab Validation

For controlled inspection in a qualified lab environment, useful for validation, complaint analysis, process verification, or detailed quality checks



Flexible Inspection Workspace

For use in a regular production workspace, technical room, workshop, or quality-control area — without the need for a dedicated lab or full line integration



One station, many inspection tasks

SANEZOO SmartCube can verify product completeness, detect visible defects, check the presence or position of components, measure and inspect selected areas of the part.

It can be used for different types of products and materials, depending on the configuration.

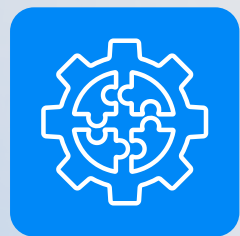

Assembled parts



Plastic components

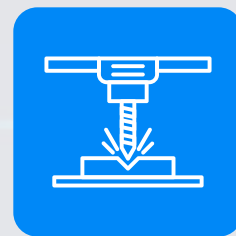

Machined surfaces

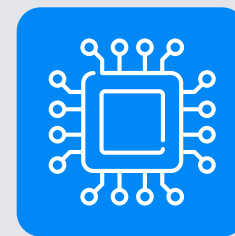

Electronic parts



Packaging

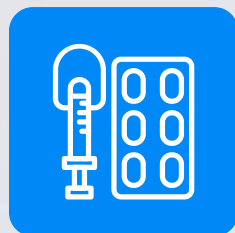

Medical products

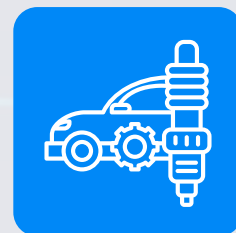

Automotive components

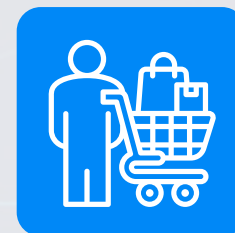

Consumer goods



Compact station, configurable setup

SANEZOO SmartCube is designed as a compact standalone inspection workplace that can be easily adjusted to different products, inspection tasks, and deployment environments.

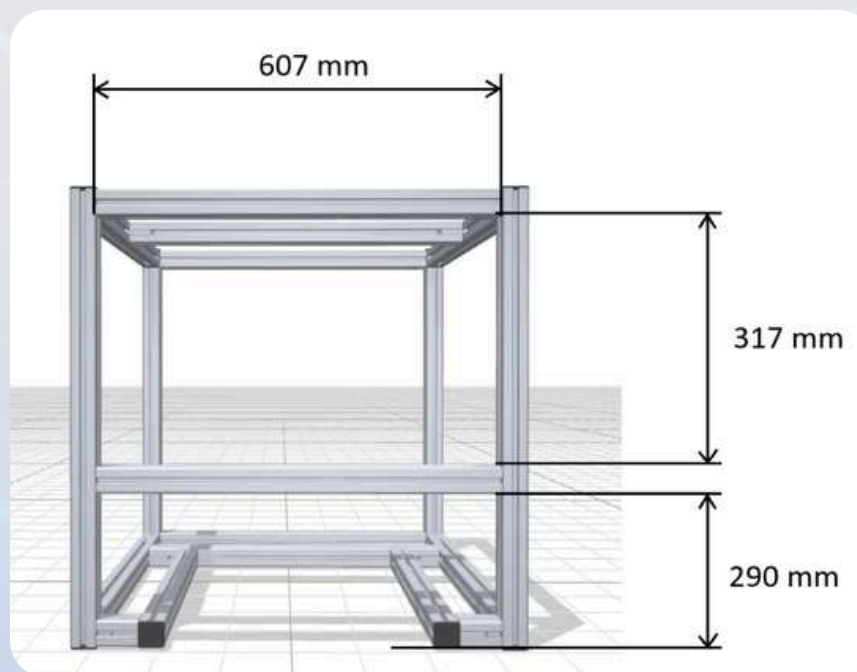

Dimensions

637 × 637 mm (configurable according to application needs)

Inspected part size

Configurable and adjustable depending on the product

Part positioning

Manual loading, semi-automatic loading, fixture-based positioning, tray-based positioning, or customized holder

Deployment

End-of-line quality check, quality lab, flexible inspection workspace

Line integration

Not required

Camera setup

Configurable according to inspection task

Lighting setup

Integrated controlled illumination (configurable according to application needs)



Sanezoo Studio

Various inspection tasks in one environment

SANEZOO Studio provides intuitive configuration for all SANEZOO products, user-friendly interfaces, and seamless integration into various environments.

It enables a wide range of applications within a single unified system – eliminating the need for multiple separate platforms.

Role-based interface – operator, admin, supervisor

Each user sees only relevant data and tools

One system for multiple processes

From barcode and OCR verification to detection, measurement, quality inspection, object validation and zone definition control

Built-in user assistants

For optics setup, exposure adjustment, part alignment, and more

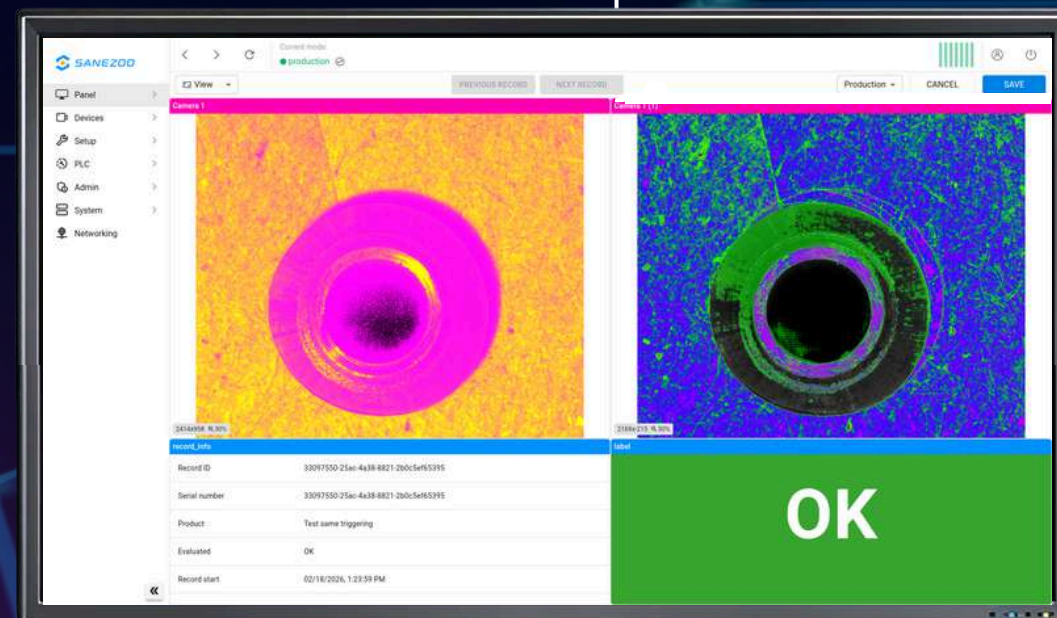
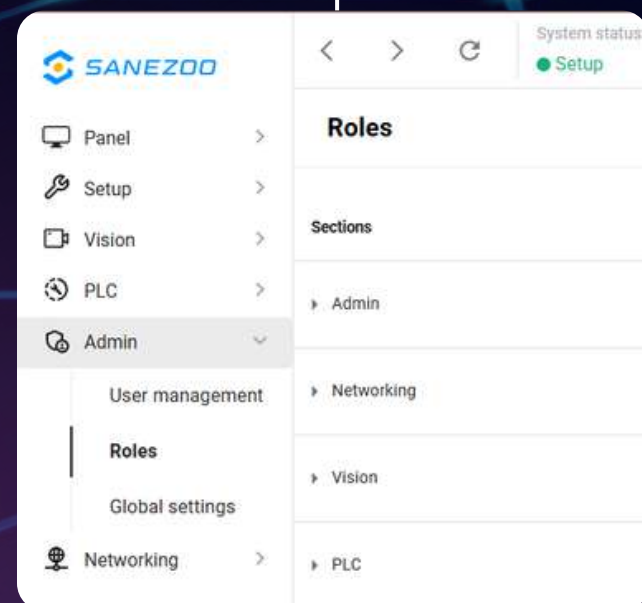

Anomaly detection

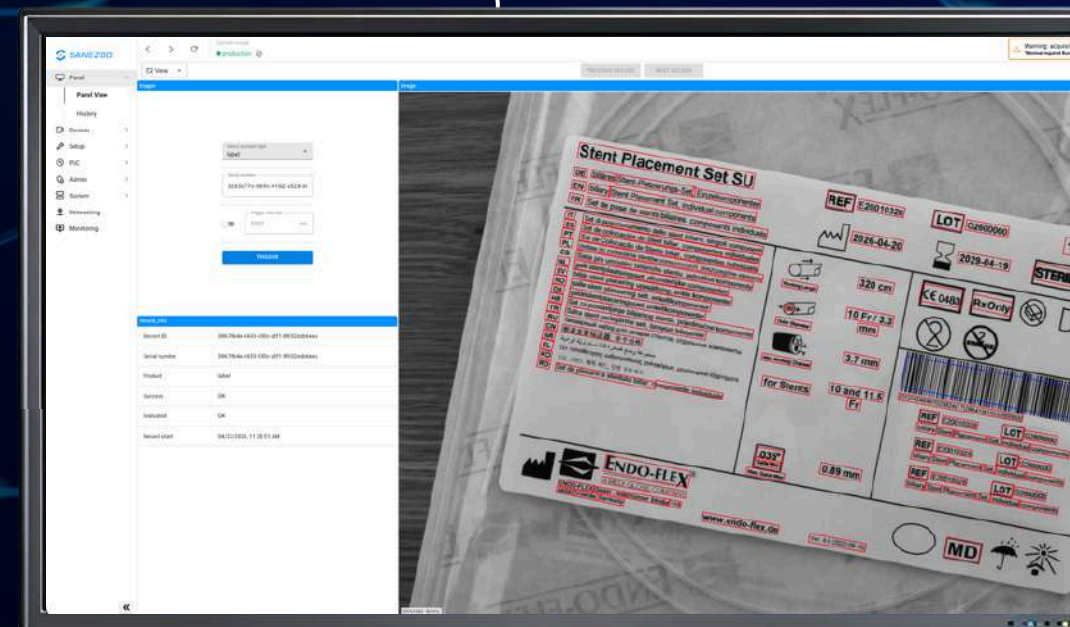

OCR verification

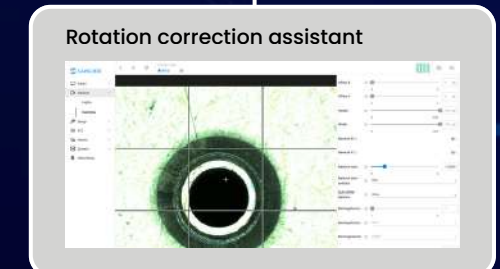
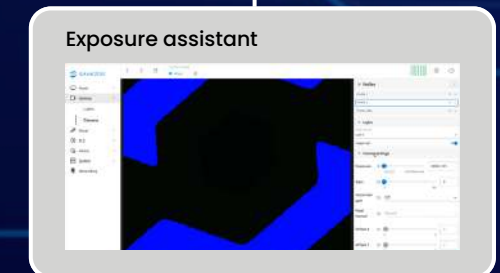
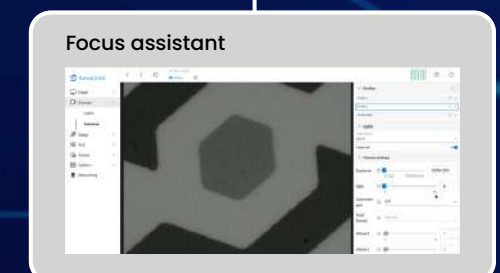

Quick business value without unnecessary complexity

Fast return on investment	ROI from approximately 10 months, depending on production volume and inspection workload
Quick deployment	Standalone plug-and-play station without the need for complex production line integration
Stable inspection results	Repeatable quality control based on defined imaging, lighting, and evaluation parameters
Lower personnel costs	Operation by non-specialist personnel with minimal training requirements
Reduced quality risks	Early detection of NOK parts helps prevent complaints, rework, and reputational damage
Flexible configuration	One station can be adapted to different products, inspection tasks, and user roles



Why choose Sanezoo

Comprehensive solutions for any task

Thanks to proprietary software and hardware development, we design solutions tailored to specific production conditions.

The combination of both layers creates a unified platform capable of addressing a wide range of industrial requirements — not limited to a single use case.



Stable quality with fast return of investment



Modular architecture

The system can be easily extended with new functionalities according to evolving needs



Controllable platform

Application logic is built from combinable modules that can be freely chained and modified



One system, endless possibilities

Unified environment for all applications — no need to train personnel on multiple separate systems



Proven ROI

Investment typically returns within 10 months through labor savings and reduced scrap rates



Margin & reputation protection

Systematic quality control eliminates unnecessary warranty costs and strengthens customer trust



References and awards

Trusted by leading industrial companies and recognized at international trade fairs.





SANEZOO®

Teach Cameras to Think

SANEZOO SE
Czech Republic
Vlněna 526/7,
602 00 Brno
+420 604 276 216
sales@sanezoo.com
sanezoo.eu

