

Pompa de testare

375/6

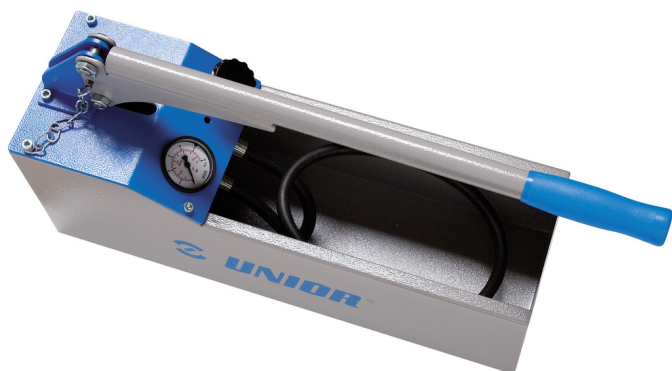

0

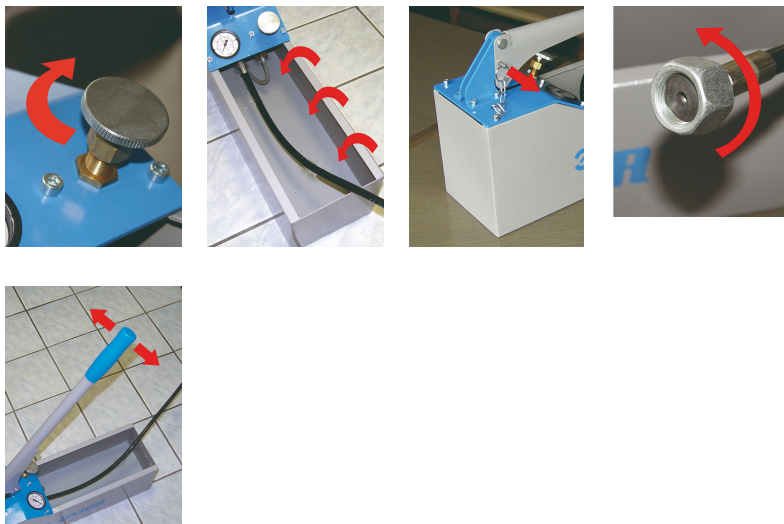

Caracteristicile produsului

- este utilizata pentru testarea presiunii si scurgerilor de apa in instalatiile de incalzire ce lucreaza sub presiune
- capacitatea maxima - 12 litri
- confectionata din material anticoroziv
- Pistonul si cilindrul sunt facute din otel inoxidabil, ghidurile si papucii sunt facute din alama. Aceste material previn coroziunea, cresc durabilitatea si ofera o viata lunga de folosire

Profile



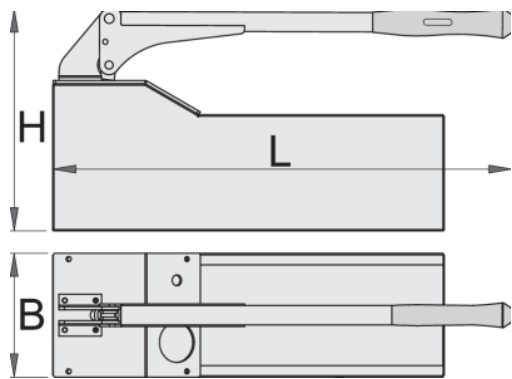

Barcode	L	B	H	Icon
---------	---	---	---	------

602600

605

160

286.5

8800

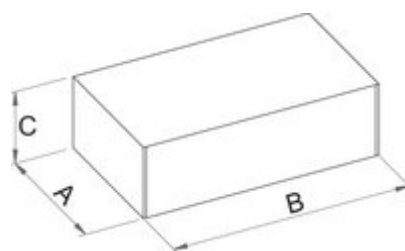

Ambalaj pentru retail

Barcode	MA	MB	MC	Icon
---------	----	----	----	------

602600

175

620

305

8800

Ambalaj pentru transport

Barcode	Hand icon	TA	TB	TC	Icon
---------	-----------	----	----	----	------

602600

1

175

620

305

8800