

Discuri de taiere pentru otel

1200/1



Caracteristicile produsului

- Partea plata intarita pentru pentru taierea unghiulara, viteza discului 80 m/s, prevazute cu o insertie metalica
- Disc de taiere OSA in conformitate cu standardul European EN 12413 (nu este permisa polizarea pe partea laterala)
- material: A30S1BF

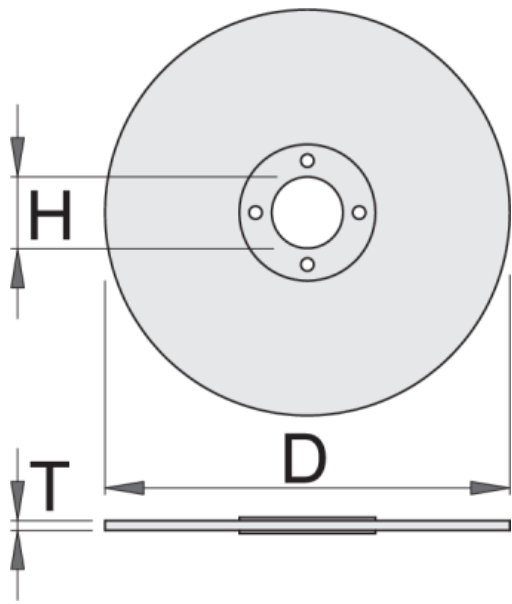

Barcode	D	T	H	Icon
610484	115	3	22	72
610485	125	3	22	87
610486	180	3	22	160
610487	230	3	22	282

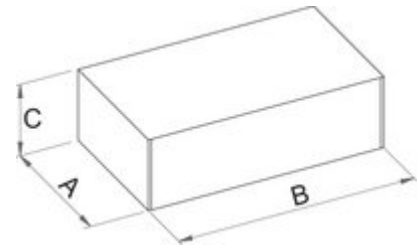

Ambalaj pentru retail

Barcode	MA	MB	MC	Icon
610484	118	118	85	142
610485	128	128	85	157
610486	181	181	90	230
610487	233	233	90	352

Ambalaj pentru transport

Barcode	Hand	TA	TB	TC	Icon
610484	1				
610485	1				
610486	1				
610487	1				