



ECOMOBILITY GENERAL CATALOGUE



ECOMOBILITY 
SCAME
electrical solutions

2015-2016



**ECOMOBILITY
GENERAL
CATALOGUE
2015-2016**

www.scame.com

Scame: a growing group

IN LESS THAN FIFTY YEARS
WE HAVE BUILT AN
INDUSTRIAL BUSINESS THAT
HAS ALWAYS PRESERVED
THE SPIRIT OF ITS ORIGINS

Scame was founded amidst the enthusiasm of the Italian economic boom of the 60's and has always pursued its raison d'être in thriving by improving. Today it is an international industrial group of about 800 people employed in 18 subsidiary and associated companies operating under the parent company headquartered in Parre (Bergamo) in Alta Valle Seriana. Scame has a capillary presence throughout Italy with its own sales agencies and operates worldwide with branches and loyal distributors.



SCAME in the world



Italy
Parre (Bergamo)

 **SCAME**^{ARGENTINA}
Argentina

 **SCAME-SEE**
Bosnia Herzegovina

 **SCAME**^{BRASIL}
Brazil

 **SCAME**^{CHILE}
Chile

 **SCAME-TOP**
China

 **SCAME-HR**
Croatia

 **SCAME-CZ**
Czech Republic

SOBEM  **SCAME**
France

 **SCAME**^{INDIA}
India



 **SCAME**_{POLSKA}
Poland

 **SCAME**_{PORTUGAL}
Portugal

 **SCAME**_{RO}
Romania

 **SCAME-SK**
Slovakia

 **SCAME**_{IBERICA}
Spain

 **SCAME**_{MIDDLE EAST}
U.A.E.

 **SCAME-UK**
United Kingdom

 **SCAME-UY**
Uruguay

 **SCAME-UA**
Ukraine

SEND AN E-MAIL TO THE
ADDRESS infotech@scame.com
AND YOU'LL RECEIVE THE
ANSWERS TO ALL YOUR
QUESTIONS ABOUT TECHNICAL
ASPECTS, INSTALLATION
AND CONFORMITY WITH THE
STANDARDS .

A decorative graphic in the bottom left corner of the page, featuring stylized green leaves and swirling vines.

The Scame technical information centre is able to promptly provide clear and complete answers to all your questions regarding the Scame products. The leading distributors of electrical material, with the support of our sales agencies and technical promoters, represent an additional capillary reference network. Information and updates can be found in the Info-point section of the internet site and in the newsletter sent periodically to the registered users.



infotech@scame.com

■ Connectors



■ Wall box

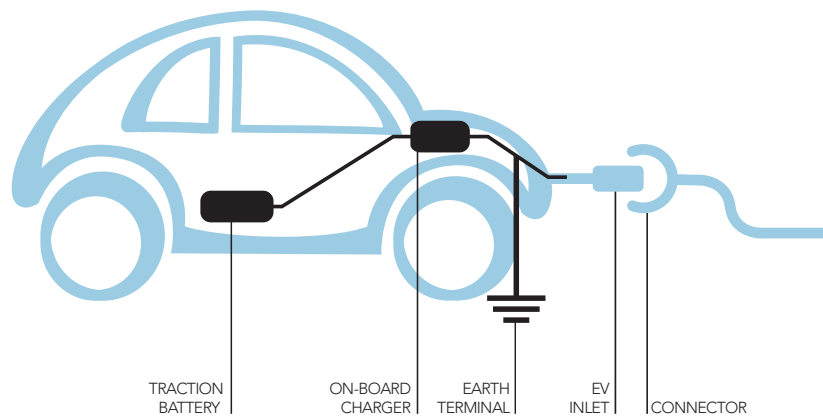



■ Cord set



■ Domino



■ Charging stations

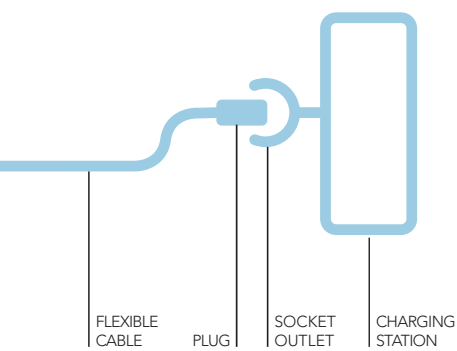

There is a great effort behind this project.

The world changes. It is inevitable. It is often a steady evolution, but at times sudden changes occur that lead to new scenarios in just a short time. The introduction of electric vehicles on the market entails the creation of new habits, new structures, and new needs. In such an evolving context, it is important to establish points of reference that guide the change; in this case, the more qualified, and thus credible, figure becomes the main player. SCAME did not hesitate for a second to offer a tangible and functional contribution in order to achieve sustainable choices from a technological, economic and environmental standpoint.

A considerable commitment, which SCAME has gladly been devoted to for many years, with the aim of providing tomorrow's drivers with practical and safe instruments.



We aim to build on good ideas.

In Europe, there are many technicians with experience and skills, but in order to make the most of this wealth it was necessary to find a way to coordinate the work being carried out, channel choices and share objectives. SCAME, in conjunction with other manufacturers strive to ensure compliance of connections used to supply electrical vehicles with IEC/CENELEC standards. All the efforts were geared towards setting up a European connecting standard capable of guaranteeing the highest levels of safety.



We set only one possible
choice for ourselves:



total safety!

European standards define possible cases for electric vehicle connection to the source of power. Within the standardization activities, SCAME has elected to develop its products by presenting original and ground-breaking solutions on the topic of safety that have been

appreciated and considered as reference standards at the European level. SCAME thus received proper recognition for the valuable expertise gained while developing its range of products with innovative spirit and designing ability.



IPXXD PROTECTION

Paragraph 11.3.2 of standard IEC/EN 61851-1 requires IPXXD protection (entry test of wire with 1-mm diameter) against accidental contact for connected and unconnected plugs in case of two-way energy transfer.

This requirement is especially important as it prevents users not trained in the use of these connectors from coming in contact with potentially live parts; moreover, it is required by most European countries.

The LIBERA Series connectors satisfy this requirement thanks to the adoption of pins and contact-tubes protected by shutters that can be opened only after the plug is inserted into the socket, as it has been for years now for domestic connectors. As the shutters satisfy the IPXXD degree of protection, the LIBERA Series connectors do not require additional sectioning devices in order to achieve an equivalent degree of protection.

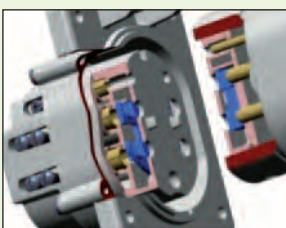

Closed shutters.

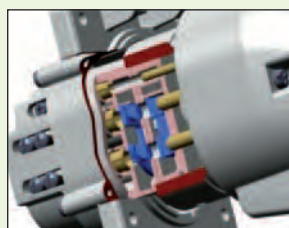

Plug shutter opening.

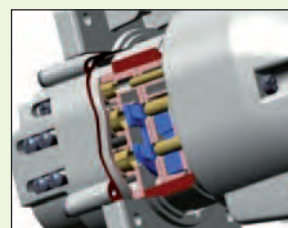

Socket shutter opening.



Complete insertion.

Our solution is simple. And efficient.

IEC/EN 61851-1: CHARGING METHODS

The reference standard for EV charging stations is the IEC/EN 61851-1, which describes four charging modes:

MODE 1

Connection of the EV to the a.c. mains using domestic connectors up to 16 A, type A 30 mA RCD (Residual Current Device) protection in upstream.



MODE 2

Connection of the EV to the a.c. mains using domestic or industrial connectors up to 32 A, type A 30 mA RCD protection, control device on the cable (ICCB In-Cable Control Box).



MODE 3

Connection of the EV to the a.c. mains with dedicated connectors, type A 30 mA RCD protection, control device in the charging station.



MODE 4

Connection of the EV to the a.c. mains with off-board battery charger.



Moreover, depending on the type of cable connection, there are three different possible cases:

CASE A

EV connection to the a.c. mains using a supply cable and plug permanently attached to the EV.



CASE B

EV connection to the a.c. mains using a detachable cable equipped with plug and socket.



CASE C

EV connection to the a.c. mains using cable and socket permanently attached to the charging station.







IEC/EN 62196-1 AND IEC/EN 62196-2: MODE 3 CONNECTORS

The reference standards for Mode 3 connectors are the IEC/EN 62196-1 and 2, and they describe three different types of connection:

CONNECTIONS



| VEHICLE | Type 1 | Type 2 |
|-----------------|---|---|
| Circuit | Single-phase | Single/three-phase |
| Current | 32 A | 70 A (single-phase) 63 A (three-phase) |
| Max. voltage | 250 V | 480 V |
| No. of contacts | 5 | 7 |
| Connector |  |  |

| STATION | Type 2 | Type 3A | Type 3C |
|-----------------|--|---|---|
| Circuit | Single/three-phase | Single-phase | Single/three-phase |
| Current | 70 A (single-phase) 63 A (three-phase) | 16 A | 63 A |
| Max. voltage | 480 V | 250 V | 480 V |
| No. of contacts | 7 | 4 | 7 |
| Connector |  |  |  |

CONNECTORS FOR ELECTRIC VEHICLES

TYPE 3A CONNECTOR

MODE **3**



Type 3A connector was launched in Italy in 2000 as the unique connection system for Mode 3 charging electric vehicles in environments open to third parties. Featuring a design derived from the SCAME IEC 309 socket-outlets, it adopted the quick snap-on device and it uses an additional CP contact for the control pilot circuit to verify the continuity of the protective conductor, in accordance with standard CEI 69-6. Given its small size, it is the preferred connector for small vehicles, such as scooters and motorcycles, with charging power lower than 3 kW. Thanks to the adaptors, it is also possible to use 3A plugs to charge in environments closed to third parties, such as private garages, in mode 1.

N.B.: The IPXXD degree of protection, and consequently the shutters, are not necessary for type 3A plugs as the vehicles for which they are designed don't require them.

REFERENCE STANDARDS

EN 62196-1 (2012)

Plugs, socket-outlets, vehicle couplers and vehicle inlets.
 Conductive charging of electric vehicles.
Part 1: General requirements.

EN 62196-2 (2012)

Plugs, socket-outlets and vehicle couplers.
 Conductive charging of electric vehicles.
Part 2: Dimensional interchangeability requirements for a.c. pin and contact-tube accessories.

CEI 69-6 (2001)

Standardization sheet of plug and socket-outlet for the connection of electric road vehicles to the supply network.

TECHNICAL CHARACTERISTICS

| | |
|------------------------|--|
| Rated current: | 16 A |
| Rated voltage: | 200-250 V AC |
| Frequency: | 50-60 Hz |
| Insulation voltage: | 250 V |
| Protection degree: | IP44 - IP54 (sockets with interlock) IPXXD (sockets) |
| Operating temperature: | -30°C to +50°C |
| Glow Wire test: | 850°C 850°C-960°C (sockets with interlock) |
| Material: | Technopolymer |
| IK Grade at 20°C: | IK07 - IK08 (sockets with interlock) |
| Colour: | Grey |
| Number of poles: | L1-N-PE-CP |
| Size of conductors: | 1 to 2.5 mm ² (plugs and connectors) 1 to 4 mm ² (flush-mounting sockets) |
| Saline solution: | Resistant |
| UV rays: | Resistant |

MODE 1 – CHARGING OF EV WITHOUT PWM IN ENVIRONMENTS CLOSED TO THIRD PARTIES

Vehicle connection to the AC mains using standardized connectors up to 16 A.

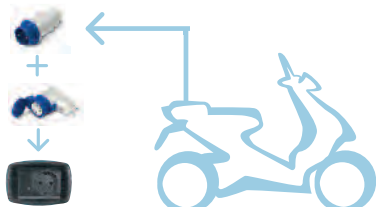

SIMPLIFIED MODE 3 – CHARGING OF EV WITHOUT PWM IN ENVIRONMENTS OPEN TO THIRD PARTIES

Vehicle connection to the AC mains using specific connectors, control pilot circuit.

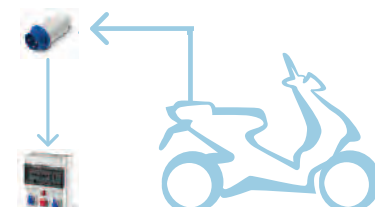

MODE 3 CHARGING OF EV WITH PWM IN ENVIRONMENTS OPEN TO THIRD PARTIES

Vehicle connection to the AC mains using specific connectors, control pilot circuit.

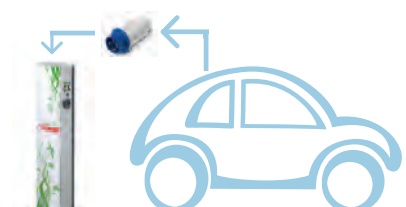



Type 3C connector is designed for electric vehicles with charging power greater than 3 kW, such as cars, promoted by the EV Plug Alliance, as a single European solution, infrastructure-side. Derived from type 3A connector, it keeps the same protection characteristics against indirect contact as well as the additional contact used to check continuity of the protective conductor.

The evolution consisting in the possibility to have both single-phase and three-phase wiring, higher rated current, introduction of the shutters on the plug side (a necessary requirement in the case of "Smart Grid") and the additional PP (Proximity Plug) contact for cable size identification. Due to the heavy-duty operating conditions, special attention was taken in the choice of materials in order to guarantee proper resistance to heat, chemical agents and mechanical stress, in compliance with the strict parameters set by the automotive industry.

REFERENCE STANDARDS

EN 62196-1 (2012)

Plugs, socket-outlets, vehicle couplers and vehicle inlets.
Conductive charging of electric vehicles.
Part 1: General requirements.

EN 62196-2 (2012)

Plugs, socket-outlets and vehicle couplers.
Conductive charging of electric vehicles.
Part 2: Dimensional interchangeability requirements for a.c. pin and contact-tube accessories.

TECHNICAL CHARACTERISTICS

| | |
|------------------------|--|
| Rated current: | 32 A |
| Rated voltage: | 380-480 V AC |
| Frequency: | 50-60 Hz |
| Insulation voltage: | 500 V |
| Protection degree: | IP44 - IP54 (sockets with interlock) (IPXXD) |
| Operating temperature: | -30°C to +50°C |
| Material: | Technopolymer |
| Glow Wire test: | 850°C 850°C-960°C (sockets with interlock) |
| IK degree at 20°C: | IK08 |
| Colour: | Grey |
| Number of poles: | L1-L2-L3-N-PE-CP-PP |
| Size of conductors: | 1.5 to 6 mm ² (plugs with screw terminals) 2.5 to 6 mm ² (plugs with crimped terminals) 1.5 to 10 mm ² (flush-mounting sockets) |
| Saline solution: | Resistant |
| UV rays: | Resistant |

LABORATORY TESTING

RESISTANCE TESTS



RESISTANCE TO CHEMICAL AGENTS

| Saline solution | Acids | | Base | | Solvents | | | | Mineral oil | UV rays |
|-----------------|--------------------|-----------|--------------------|-----------|---------------|---------------|---------------|--------------------|-------------|-----------|
| | Concentrated | Diluted | Concentrated | Diluted | Hexane | Benzol | Acetone | Alcohol | | |
| Resistant | Limited resistance | Resistant | Limited resistance | Resistant | Not resistant | Not resistant | Not resistant | Limited resistance | Resistant | Resistant |

T Y P E 2 C O N N E C T O R W I T H S H U T T E R S

M O D E 3



The current standard type 2 connector provides a IPXXB degree of protection for socket outlets installed on charging stations. Since this degree of protection is unsuitable for the concerned application, type 2 must be joined with a device upstream that ensures complete isolation.

The SCAME solution using the shutters, as already done for the type 3A, 3C and domestic connectors, can upgrade the degree of protection to IPXXD, ensuring protection against direct contact with potentially live parts.

The type 2 connector with shutters, apart from meeting the expectations of the European Commission, also fulfils the safety requirements for domestic environments required by the regulations and laws of most European Union member states.

REFERENCE STANDARDS

EN 62196-1 (2012)

Plugs, socket-outlets, vehicle couplers and vehicle inlets.
 Conductive charging of electric vehicles.
Part 1: General requirements.

EN 62196-2 (2012)

Plugs, socket-outlets and vehicle couplers.
 Conductive charging of electric vehicles.
Part 2: Dimensional interchangeability requirements for a.c. pin and contact-tube accessories.

TECHNICAL CHARACTERISTICS

| | |
|------------------------|---------------------------|
| Rated current: | 32 A |
| Rated voltage: | 380-480 V AC |
| Frequency: | 50-60 Hz |
| Insulation voltage: | 500 V |
| Protection degree: | IP55 (mated) (IPXXD) |
| Operating temperature: | -30°C to +50°C |
| Material: | Engineering plastic |
| Glow Wire test: | 850°C-960°C |
| IK Grade at 20°C: | IK08 |
| Colour: | Black |
| Number of poles: | L1-L2-L3-N-PE-CP-PP |
| Size of conductors: | 2.5 to 10 mm ² |
| Saline solution: | Resistant |
| UV rays: | Resistant |

T Y P E 2 W I T H O U T S H U T T E R S

Type 2 connector is designed for electric vehicles with charging power greater than 3 kW, such as cars. It was adopted by German manufacturers and selected by the European Commission as a standard solution on the infrastructure-side.

As the 3C-type connector can be wired in both single-phase and three-phase, it has the same contacts arrangement (CP and PP contacts).

Since the type 2 connector cannot be disconnected under load, the SCAME type 2 socket already provides an interlocking mechanism that blocks the plug during the charging and that closes the lid when the socket is not engaged. The latching device is operated by a single 2-position actuator.

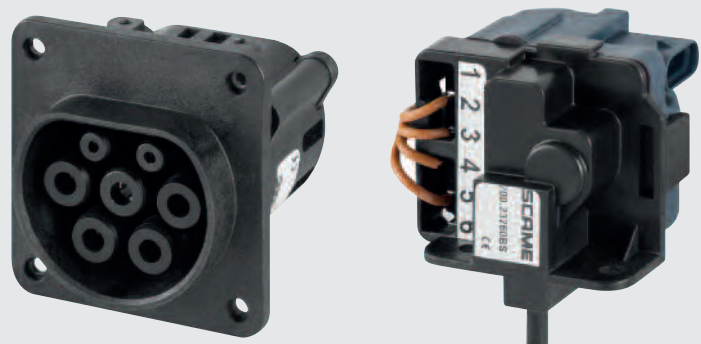



The cord-set is used to connect the vehicle to the charging station. It consists of a plug for infrastructure-side connection, a connector (movable socket) for the vehicle side, a cable with adequate cross-section and polarity suited to mobile use, particularly resistant to operating conditions.

Compared to case A (cord-set fixed to the vehicle) and case C (cord-set fixed to the charging station), case B is the more versatile one thanks to the compatibility that can be achieved between the various standards in use today in the international scenario of connections.

TECHNICAL CHARACTERISTICS

| | |
|------------------------|-----------------------------|
| Rated current: | 16 A / 20 A / 32 A |
| Rated voltage: | 200-250 V AC / 380-480 V AC |
| Frequency: | 50-60 Hz |
| Insulation voltage: | 250/500 V |
| Protection degree: | IP44 |
| Operating temperature: | -30°C to +50°C |
| Material: | Technopolymer |
| Saline solution: | Resistant |
| UV rays: | Resistant |

REFERENCE STANDARDS

EN 62196-1 (2012)

Plugs, socket-outlets, vehicle couplers and vehicle inlets.

Conductive charging of electric vehicles.

Part 1: General requirements.

EN 62196-2 (2012)

Plugs, socket-outlets and vehicle couplers.

Part 2: Dimensional interchangeability requirements for a.c. pin and contact-tube accessories.

CEI 69-6 (2001)

Standardization sheet of plug and socket-outlet for the connection of electric road vehicles to the supply network.

SAE J1772 (2012)

Electric vehicle and plug in hybrid electric vehicles conductive charge coupler.

CABLE

| | |
|-------------------------|-----------|
| Rated voltage: | 300/500 V |
| Wire insulation/sheath: | TPE / TPE |
| Maximum temperature: | +105°C |

LATCHING SYSTEM

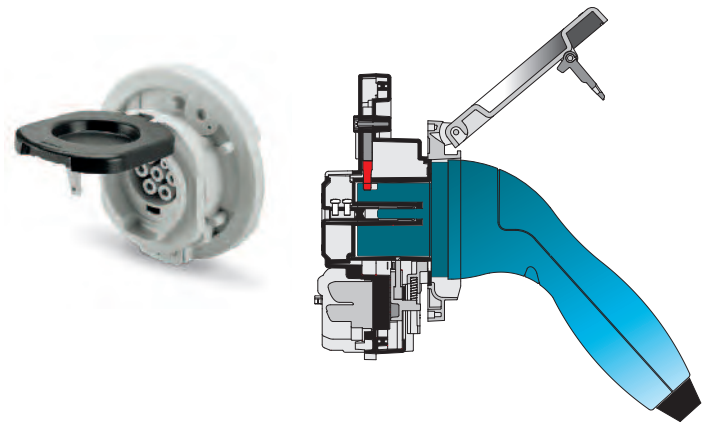
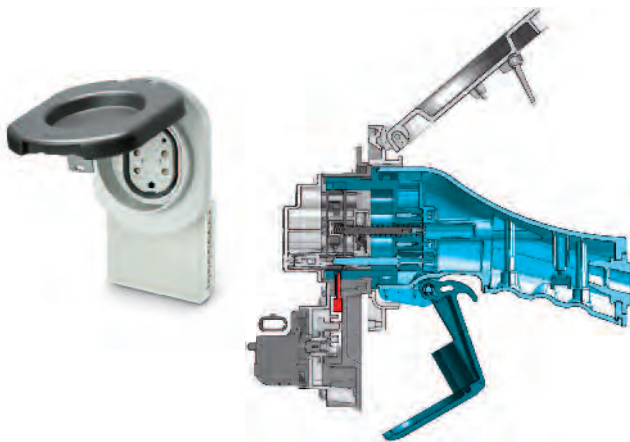
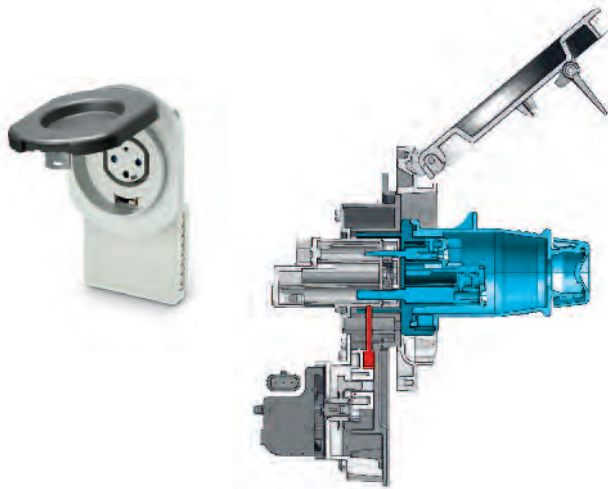

The flush-mounting socket-outlets of the LIBERA Series are also available in the optional version with built-in latching system in order to avoid accidental or intentional extraction of the plug in charging stations located in unsupervised places, such as squares and roads. The locking function is achieved by means of a pin, operated by a bi-stable actuator that also blocks the opening of the cover in the resting position.

For proper system management, the socket also provides the position status of the lock (inserted/not inserted) and of the cover (closed) by means of 3 built-in micro switches. All plugs included in the LIBERA Series are also equipped with a hole in the bottom part of the body in which the pin is housed.

Sockets with the locking function are supplied with no actuator piloting systems, consequently the operating principle shown in the figures at the side presupposes coupling to an external control system supplied by Scame in the case of assembled systems.

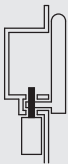
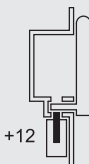
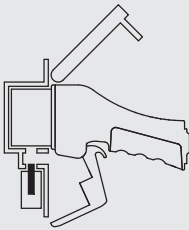
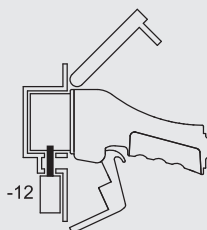
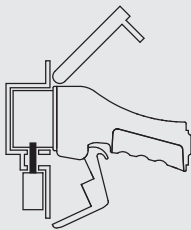
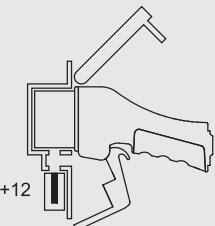
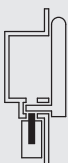
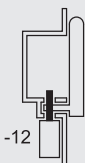
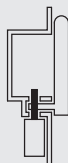
| | | | | |
|---|---|--|--|---|
| <p>1. Idle.</p>  | <p>2. User identification (RFID). Lock opening.</p>  | <p>3. Cover opening. Plug insertion.</p>  | <p>4. User identification (RFID). Lock closing.</p>  | <p>5. Charging.</p>  |
| <p>6. User identification (RFID). Lock opening.</p>  | <p>7. Plug removal. Cover closing.</p>  | <p>8. Lock closing.</p>  | <p>9. Idle.</p>  | |

The legislative scenario is complex



While contributing to defining the new standards, SCAME put technology at the service of common sense, with the aim of pursuing practical and intelligent design choices. Indeed, the choices made when defining connection methods and designing the relevant equipment have led to the offer of simple and safe products. This means that the utilization methods are perfectly suited to the user, that production costs are low and that safety is ensured.

The connection developed by Scame

CHARGING MODE 3

SCAME's charging stations use charging mode 3, in accordance with IEC / EN 61851-1.

Charging mode 3 consists in connecting the vehicle to the AC mains using specific connectors and with a control pilot circuit inside the charging station to verify continuity of the protective conductor between vehicle and grid during the charging.

This check is necessary to ensure proper operation of protections against indirect contacts, hence to prevent any dangerous voltage from being discharged through accidental contact with unaware persons; it is usually mandatory for vehicles with power above 3 kW, and, in Italy, for public or private environments open to third parties. The control circuit also arranges for communication between charging station and vehicle (PWM Circuit) and for cable size identification (Resistor Coding).

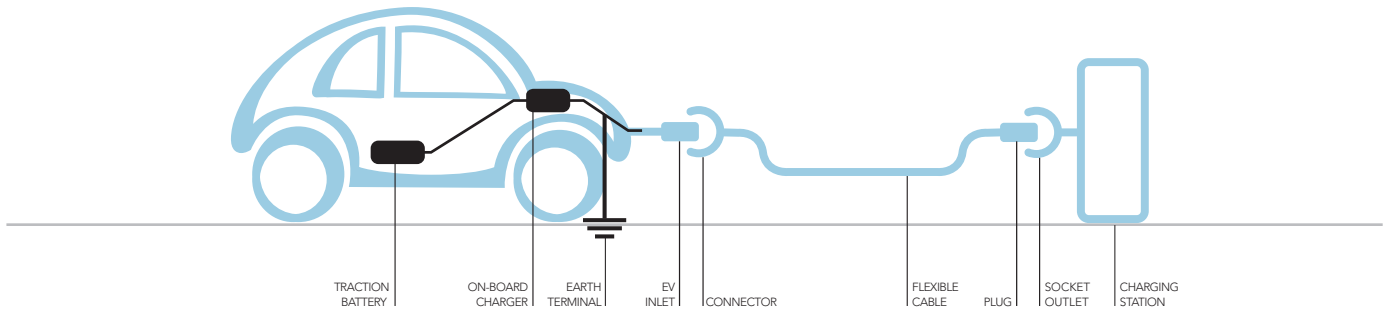

MODE 3 PWM CIRCUIT (PULSE WIDTH MODULATION)

PWM circuit operation is described in Annex A of standard IEC/EN 61851-1. This circuit arranges for communication between charging station and electric vehicle: the station communicates the supply network availability to the vehicle through a frequency-modulated signal, the vehicle adjusts the load returning its status through a voltage value.

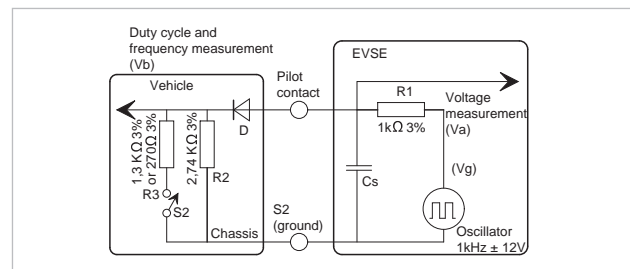

"SIMPLIFIED" MODE 3

In the case of vehicles without PWM, the circuit operates in "simplified mode", measuring the earth resistance value only and limiting the charging current to 16 A (10 A in the future).

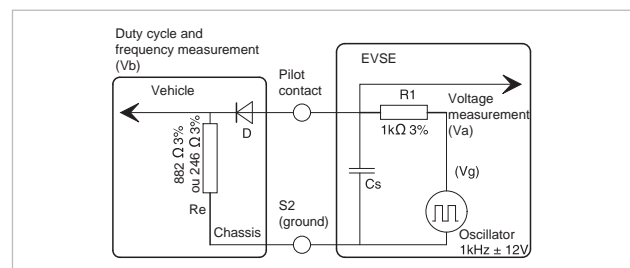

RESISTOR CODING

Resistor Coding operation is described in Annex B.5 of standard IEC / EN 61851-1 and it is mandatory in the case of 3C type connectors, type 1 and type 2, when it is possible to wire the plug using cables with different cross-sections and current carrying capability. Depending on the max charging current, a resistance is positioned between the PP contact and the earth, with a value that identifies cable size. The PWM circuit then checks that the charging current does not exceed the maximum drawable current.

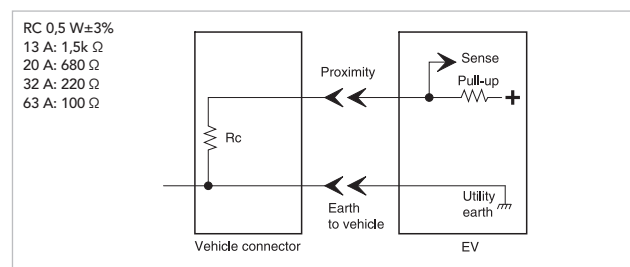



The Wall Box is a wall-mounted charging station with the same features as the UB versions, yet featuring a dedicated design that makes it suitable for installation in domestic or similar environments.

TECHNICAL CHARACTERISTICS

| | |
|------------------------|----------------|
| Rated current: | 16 A / 32 A |
| rated voltage: | 230 V AC |
| Frequency: | 50-60 Hz |
| Insulation voltage: | 250 V |
| Protection degree: | IP54 |
| Operating temperature: | -25°C to +40°C |
| Material: | Technopolymer |
| Glow Wire test: | 650°C |
| IK grade at 20°C: | IK08 |
| Colour: | Grey |
| Installation: | Wall-mounted |
| Saline solution: | Resistant |
| UV rays: | Resistant |

REFERENCE STANDARDS

EN 61851-1 (2011)

Electric vehicle conductive charging system.

Part 1: General requirements.

EN 61439-1 (2011)

Low-voltage switchgear and control gear assemblies.

Part 1: General requirement.

FEATURES

- Mode 3 charging with PWM pilot circuit
- Identification of connected cable size
- Protection against overloads and indirect contacts
- Measurement of power output and current drawn
- Control of proper contactor opening
- Identification of users authorized to the charging
- Management of plug interlock system
- Operation in free stand-alone or personal mode
- Set up for serial communication

APPLICATION EXAMPLES



UB DOMINO UNITS

MODE 3



UB switchboards are wall-mounted charging stations using the modular composition possibilities offered by the SCAME Domino Series switchboards.

TECHNICAL CHARACTERISTICS

| | |
|------------------------|---------------------|
| Rated current: | 16 A / 32 A |
| Rated voltage: | 230 V AC / 400 V AC |
| Frequency: | 50-60 Hz |
| Insulation voltage: | 250 V / 500 V |
| Protection degree: | IP44 - IP54 |
| Operating temperature: | -25°C to +40°C |
| Material: | Technopolymer |
| Glow Wire test: | 650°C |
| IK grade at 20°C: | IK07 |
| Colour: | Grey |
| Installation: | Wall-mounted |
| Saline solution: | Resistant |
| UV rays: | Resistant |

REFERENCE STANDARDS

EN 61851-1 (2011)

Electric vehicle conductive charging system.
 Part 1: General requirements.

EN 61439-1 (2011)

Low-voltage switchgear and control gear assemblies.
 Part 1: General requirement.

FEATURES

- Mode 3 charging with PWM pilot circuit
- Identification of the connected cable size
- Protection against overloads and indirect contacts
- Measurement of power output and current drawn
- Control of proper contactor opening
- Identification of users authorized to the charging
- Management of cover locking and plug interlock system
- Management of charging in case of power failure (optional)
- Operation in free stand-alone or personal mode
- Set up for serial communication

APPLICATION EXAMPLES





The CA charging column is a free-standing, two-sided charging station made of painted steel sheet that can be equipped with type 2, 3A, 3C and domestic socket-outlets having a built-in anti-extraction locking system and with movable outlets with permanently connected cable (case C connection). Suited for private or public open areas, these columns feature removable front panels in Plexiglas that allow quick and easy customization.

TECHNICAL CHARACTERISTICS

| | |
|------------------------|---------------------------|
| Rated current: | 16 A - 32 A - 50 A - 63 A |
| Rated voltage : | 230 V AC / 400 V AC |
| Frequency: | 50-60 Hz |
| Insulating voltage: | 250 V / 500 V |
| Protection degree: | IP54 |
| Operating temperature: | -25°C to +40°C |
| Material: | Steel sheet |
| Glow Wire test: | - |
| IK grade at 20°C: | IK10 |
| Colour: | Grey |
| Installation: | Free-standing |
| Saline solution: | Resistant |
| UV rays: | Resistant |

REFERENCE STANDARDS

EN 61851-1 (2011)

Electric vehicle conductive charging system.

Part 1: General requirements.

EN 61439-1 (2011)

Low-voltage switchgear and control gear assemblies.

Part 1: General requirement.

FEATURES

- Mode 3 charging with PWM pilot circuit
- Identification of the connected cable
- Protection against overloads and indirect contacts
- Measurement of power output and current drawn
- Control of proper contactor opening
- Identification of user authorized to the charging
- Management of cover locking and plug interlock system
- Management of charging in case of power failure
- Operation in free stand-alone or personal mode
- Set up for serial communication

APPLICATION EXAMPLES



Head with LED indications



LED display with RFID reader



Customizable front panel



Compartment protected by door with lock



Separating plate for cable entry



Free-standing base with separating chamber

CB CHARGING STATION

MODE 3



The CB charging column is a free-standing, two-sided charging station with the same features as the CA column but made of stainless steel sheet instead and with a smart design. Suited for private and public open areas and for environments requiring greater corrosion resistance.

TECHNICAL CHARACTERISTICS

| | |
|------------------------|----------------|
| Rated current: | 16 A – 32 A |
| Rated voltage: | 400 V AC |
| Frequency: | 50-60 Hz |
| Insulation voltage: | 500 V |
| Protection degree: | IP54 |
| Operating temperature: | -25°C to +40°C |
| Material: | AISI 304 steel |
| Glow Wire test: | - |
| IK grade at 20°C: | IK10 |
| Colour: | Satin-finished |
| Installation: | Free standing |
| Saline solution: | Resistant |
| UV rays: | Resistant |

REFERENCE STANDARDS

EN 61851-1 (2011)

Electric vehicle conductive charging system.
 Part 1: General requirement..

EN 61439-1 (2011)

Low-voltage switchgear and control gear assemblies.
 Part 1: General requirement.

FEATURES

- Mode 3 charging with PWM pilot circuit
- Identification of the connected cable size
- Protection against overloads and indirect contacts
- Measurement of power output and current drawn
- Control of proper contactor opening
- Identification of user authorized to the charging
- Management of cover locking and plug interlock system
- Management of charging in case of power failure
- Operation in free stand-alone or personal mode
- Set up for serial communication

APPLICATION EXAMPLES



Head with LED indications



LED display with RFID reader



Flush-mounting outlet with door



Compartment protected by door with lock



Separating plate



Free-standing with separating chamber

RES(ource) is more than just an equipment device used to charge electric vehicles. RES(ource) is also a source of energy, communication and services. A successful blend of design and functionality, it expresses through its shape and colours the vocation to fit in historical, architectural and valuable landscapes, typical of the Italian scenery.

TECHNICAL CHARACTERISTICS

| | |
|------------------------|-----------------------------|
| Rated current: | 32 A |
| rated voltage: | 400 V AC |
| Frequency: | 50-60 Hz |
| Insulation voltage: | 500 V |
| Protection degree: | IP54 |
| Operating temperature: | -25°C to +40°C |
| Material: | Corten steel - Steel sheet |
| Glow Wire test: | - |
| IK grade at 20°C: | IK10 |
| Colour: | Oxidized (rust-like) - Grey |
| Installation: | Free-standing |
| Saline solution: | Resistant |
| UV rays: | Resistant |

FEATURES

- Mode 3 charging with PWM pilot circuit
- Identification of the connected cable size
- Protection against overloads and indirect contacts
- Measurement of power output and current drawn
- Control of proper contactor opening
- Management of service based on the available credit
- Management of cover locking and plug interlock system
- Management of charging in case of power failure
- Operation in free stand-alone or personal mode
- Set up for serial communication



Customisable advertising

Coin payment

2 socket-outlets

Design with low environmental impact

REFERENCE STANDARDS

EN 61851-1 (2011)

Electric vehicle conductive charging system.
Part 1: General requirements.

EN 61439-1 (2011)

Low-voltage switchgear and control gear assemblies.
Part 1: General requirement.

APPLICATION EXAMPLES





ZE READY CERTIFICATION PROCEDURE FOR POTENTIAL PARTNER

- Acceptance of the collaboration contract
- Participation in the technical course at SCAME covering the following topics:
 - Reference standards
 - Installation, configuration and use of SCAME charging stations
 - Additional ZE READY requirements
- Installation of products according to:
 - Current standards
 - Technical manual
 - ZE READY requirements
- Filling in the installation report
- Affixing the label.

ZE READY LABEL is a quality brand owned by Renault that guarantees full compatibility of the charging infrastructure with ZE Renault vehicles.

When affixed, it ensures that the charging stations and their installation, are carried out in compliance with specific requirements established by the members of the ZE Ready workshop, which anticipate upcoming rules and regulations concerning the charging of electric vehicles in order to ensure their safety and performance.

ZE READY is a trademark granted by Renault to accredited partners. The right to use the trademark is only given to companies that have control over the product and its installation. SCAME stations have been tested and accredited in conformity with ZE READY 1.2 requirements, so any installer that wishes to successfully comply with ZE READY expectations can become SCAME's partner. For more information about SCAME products, the certification process and how to become a partner, please contact SCAME at info@scame.com.



For the software we

A truly complete project cannot be limited to defining the technical characteristics of the equipment. In such a complex scenario such as the one that is evolving in this sector, it is crucial to provide for advanced utilization modes of the power supply system, taking advantage of plant management technologies that allow an optimization of equipment use.

SCAME has provided for the interaction with sophisticated control and management tools, also developing an advanced software system that makes the SCAME world compatible with the most depending market requirements.



component have worked hard

CONTROL CARD

Scame's charging stations are equipped with a control card that was developed in cooperation with our partner, GENERALE SISTEMI, which supplies basic functions such as PWM circuit, resistor coding, energy measurement, RFID user identification, indicator lights and RS485 serial communication.

Depending on the versions, additional functions such as emergency power supply, display management, anti-extraction locking and lights command are provided by a special expansion module.

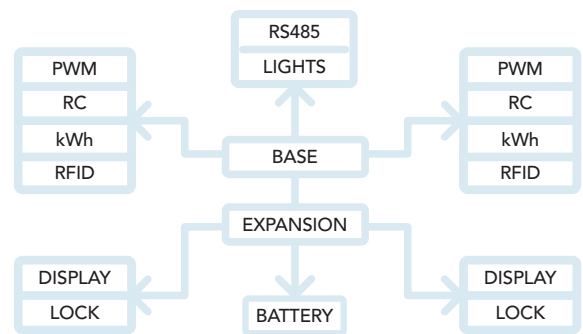
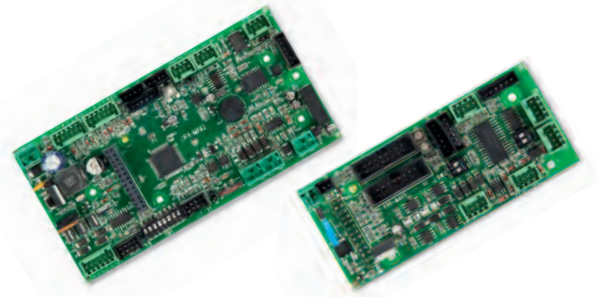

USER INTERFACE

204.CAXXX



204.CBXXX



204.UBXX

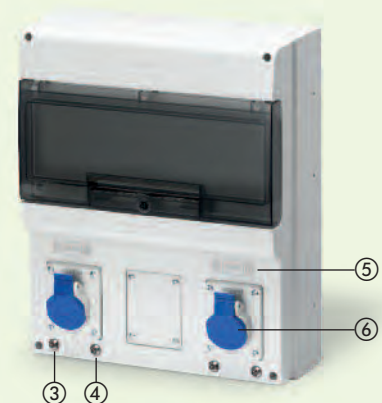

- ① GENERAL LIGHTS: if blue, charging in progress; if green, ready to charge; if red, there is a failure; if OFF there is no AC mains.
- ② LCD DISPLAY: provides the user with instructions on how to charge and displays information regarding the charging process and about any anomaly.
- ③ WHITE OPERATING LED: if ON it indicates normal operation; if flashing, control or programming is in progress.
- ④ BLUE OPERATING LED: if ON indicates charging is in progress; if flashing charging is suspended.
- ⑤ RFID READER: to enable/stop the charging or open the socket-outlet cover, the User Card must be placed over this area.
- ⑥ STOP CHARGE BUTTON (free mode)
- ⑦ SOCKET-OUTLET: depending on the version, can be type 1, type 2, type 3A, 3C or domestic, with or without interlocking device, complies with IEC 62196-1 and 2.

Three configurations for charging

STAND-ALONE

The charging stations are not connected together and operate independently. The station administrator can leave them in free charging mode (FREE) or limit the charge to authorized users (PERSONAL). Through the card programmer, the administrator can nevertheless control the charging depending on a specific time interval and/or the number of accesses.



ACTIVE CARD

Each User Card can be programmed by assigning an expiry date and/or a limited number of accesses through the 208.PROG programmer, to be connect to one's PC, and the supplied SActive software.

SActive software

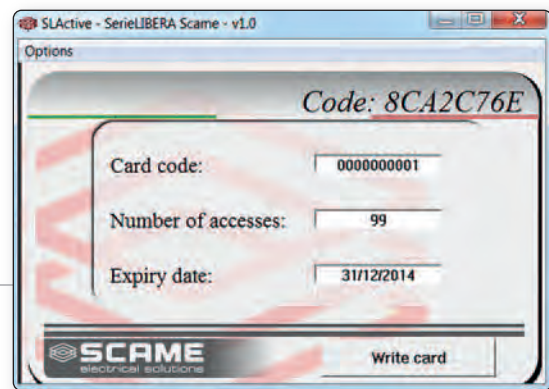

WEB

The stations are connected together to local server and by a GPRS/ADSL modem the data are transferred to the web server (master server).

The station administrator accesses the web server to manage users, monitor and configure the stations, calculate consumption, etc. Users also can access the web server only as far as their own account is concerned. The development of systems that take advantage of station connection to a web server is entrusted to our partner, GENERALE SISTEMI, which operates the service.

WEB SERVICES

The services via the Internet developed by SCAME in cooperation with GS SISTEMI offer the following solutions:

- real-time display of system status (column free, busy, charging, etc.);
- recording of consumption;
- calculation of statistics on column use and availability.
- monitor of failures/malfunctions

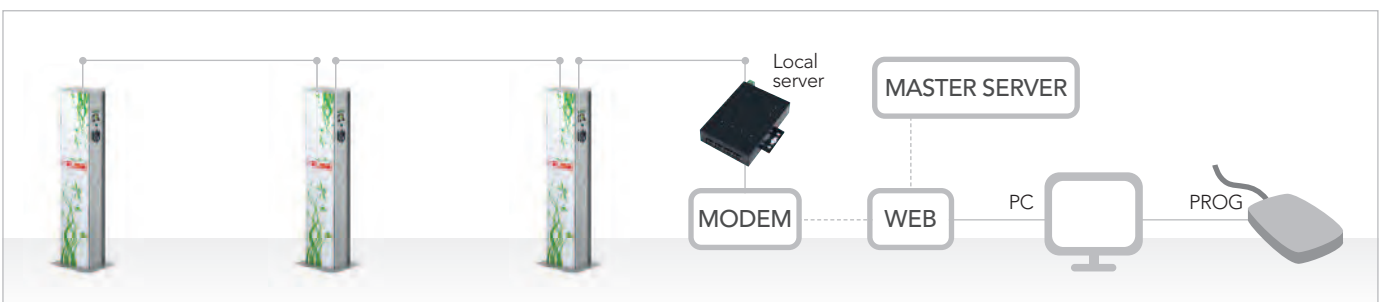

stations

NET

The charging stations are connected together and to a local server, which can only be accessed by the station administrator. In addition to being a data concentrator, the server contains the standard software developed in cooperation with our technological partner, GENERALE SISTEMI, through which it is possible to manage users, monitor and configure the charging stations, record consumptions, etc. Through the card programmer, the administrator can nevertheless control the charging depending on a specific time interval and/or the number of accesses.

The services are managed through a local server located nearby the columns.

The system used to manage SCAME's charging stations does not require the installation of software in order to work, as the program is already installed on the server.

The operating status of the outlets of the connected stations is reported in real time on the web page shown here below.



Local server with standard management software

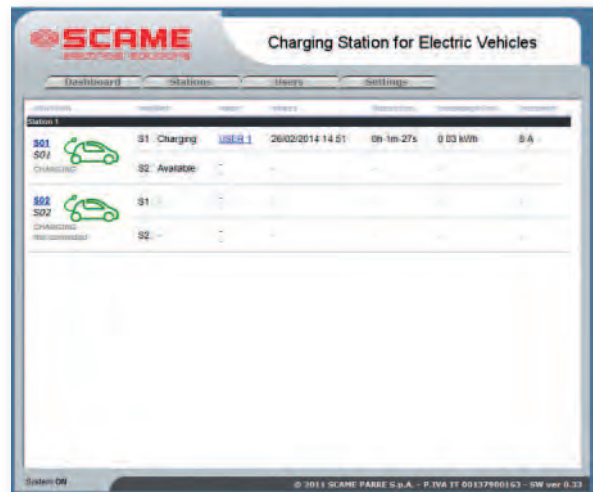

LAN



WLAN

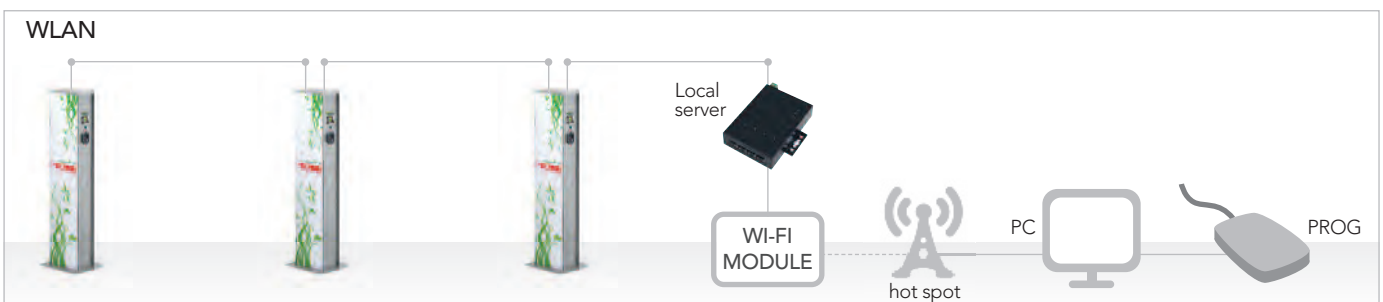

ALTERNATIVE SOLUTIONS

To complete its product range, SCAME offers the Fast Charge quick charging stations in Mode 4.

REFERENCE STANDARDS

EN 61851-1 (2011)

Electric vehicle conductive charging system.
Part 1: General requirements.

IEC 61439-1 (2011)

Low-voltage switchgear and control gear assemblies.
Part 1: General requirement.

N.B:

- The term "fast charge" means the ability of a battery to charge up to 80% of capacity in 10/15 minutes.
- Mode 4 consist in a DC supply of the vehicle using a dedicated connector that allows even a digital communication between vehicle and station. The most used standards today are:
 - CHAdeMO is the name of the Japanese association that promotes this charging mode, which requires the use of dedicated connectors, pre-setting the vehicle for this charging mode, and digital communication between vehicle and charging station defined by a proprietary protocol (CAN bus).
 - The Combined Charging System (CCS) Type 2, also called "COMBO 2", supports both conventional a.c. charging and fast d.c. charging. Both connectors fit into the vehicle inlet and the communication is provided by power line. COMBO 2 is a standard promoted by the German carmakers. The European Commission specified the use of the COMBO 2 according to IEC 62196 as a common standard throughout Europe.

CHAdeMO CHARGING STATION (CH) MODE 4



CHAdeMO connector



FEATURES

- Mode 4 charging according to CHAdeMO standard
- Electronic protection system:
 - Revers polarity
 - Short circuit
 - Anti-arcing
 - Over temperature
- Protection against overloads and indirect contacts
- Charging history (200 charge cycles)
- Management of charging in case of power failure
- Operation in stand-alone free mode
- Set up for serial communication

TECHNICAL CHARACTERISTICS

| | |
|------------------------|----------------|
| Input voltage: | 400 V AC |
| Input current: | 32 A - 80 A |
| Frequency: | 50-60 Hz |
| Output voltage: | 50-600 V DC |
| Output current: | 125 A Max. |
| Efficiency: | > 92% |
| Power factor: | 0.95 |
| Protection degree: | IP54 |
| Operating temperature: | -25°C to +40°C |
| Material: | Steel sheet |
| Glow Wire test: | - |
| IK grade at 20°C: | IK10 |
| Colour: | Grey |
| Installation: | Free-standing |
| Saline solution: | Resistant |
| UV rays: | Resistant |

MOBILE CHARGING STATION

MODE 4



CHAdEMO connector



Combo 2 connector



FEATURES

- Mode 4 charging according to CHAdEMO standard
- Mode 4 charging according to DIN 70121 protocol
- Mode 3 charging with PWM circuit
- Protection against short-circuit, overcurrent, overvoltage and residual current
- Monitoring of earth resistance and insulation
- Operation in stand-alone free mode
- Set up for serial communication

TECHNICAL CHARACTERISTICS

| | |
|------------------------|------------------|
| Input voltage: | 400 V AC |
| Input current: | 28 A - 32 A |
| Frequency: | 50-60 Hz |
| Output voltage: | 170-500 V DC |
| Output current: | 50 - 60 A max. |
| Efficiency: | > 93 % |
| Power factor: | 0.99 |
| Protection degree: | IP54 |
| Operating temperature: | 25°C to +40°C |
| Material: | Galvanized steel |
| IK Grade at 20°C: | IK10 |
| Colour: | White |
| Saline solution: | Resistant |
| UV rays: | Resistant |

COMBINED CHARGING STATION



CHAdEMO connector



Combo 2 connector



Type 2 socket-outlet



APPLICATION EXAMPLES





There are several electric vehicles on the market today that, due to their construction, do not fall within the charging modes covered by standard EN61851 - 1 (e.g., scooters/ bike with off-board battery charger) .

For these vehicles, SCAME has developed special versions of its domestic connectors that have the same technical features of mode 3 connectors to be 'exploited' (such as inserted plug detection and anti-extraction lock system), so that they can be used in SCAME's charging infrastructure.

N.B.: Please note remember that in Italy, domestic connectors are not suited for charging electric vehicles in mode 1 in environments open to third parties.

TECHNICAL CHARACTERISTICS

| | |
|------------------------|---|
| Rated current: | 16 A |
| Rated voltage: | 200 - 250 V AC |
| Frequency: | 50-60 Hz |
| Insulation voltage: | 250 V |
| Protection degree: | IP54 (IPXXD) |
| Operating temperature: | -25°C to +35°C -30°C to +50°C (sockets with interlock) |
| Material: | Technopolymer |
| Glow Wire test: | 650°C-750°C 850-960 / (sockets with interlock) |
| IK grade at 20°C: | IK08 |
| Colour: | Grey / Light blue |
| Number of poles: | L1-N-PE-CP |
| Size of conductors: | 1 to 4 mm ² |
| Saline solution: | Resistant |
| UV rays: | Resistant |

REFERENCE STANDARDS

EN 60884-1

Plugs and socket-outlets for household and similar purposes.

Part 1: General requirements.

UNEL SOCKET-OUTLET WITH INTERLOCK

The flush-mounting socket-outlets of the LIBERA Series are also available in the UNEL version with built-in plug locking device for a charging system in mode 1 having the same features as the socket-outlets with lock in mode 3.

In this case, however, the anti-extraction function is obtained by locking the lid opening even when the plug is inserted.

The use of this socket-outlet is allowed only in areas where mode 3 is not mandatory. The socket-outlet is supplied without the external actuator. Operation is guaranteed only with the UNEL plug.



EVOBIKE CHARGING STATION

DC



FEATURES

- Charging in DC standard EvoBike mode
- Protection against overloads and indirect contacts
- Identification of users authorized to the charging
- Management of cover locking and plug interlock system
- Operation in free stand-alone or personal mode

TECHNICAL CHARACTERISTICS

| | |
|------------------------|------------------------------|
| Rated current: | 32 A |
| Rated voltage: | 230 V AC |
| Frequency: | 50-60 Hz |
| Insulation voltage: | 250 V |
| Protection degree: | IP44 |
| Operating temperature: | -25°C to +40°C |
| Material: | Steel sheet |
| Glow Wire test: | - |
| IK grade at 20°C: | IK10 |
| Colour: | Anthracite |
| Installation: | Wall-mounted / free-standing |
| Saline solution: | Resistant |
| UV rays: | Resistant |

To increase its product range, SCAME also offers charging stations in DC for vehicles that are equipped with an external battery charger and are therefore not covered by current standards.

This is a bar structure that can be easily integrated in a cantilever roof sheltering; it contains the control and identification electronic parts and can house the battery charger best suited for the vehicle to be charged (not included). The system also includes a connecting system which the vehicle must equip itself, based on a proprietary connector standard.

REFERENCE STANDARDS

EN 61851-1 (2011)

Electric vehicle conductive charging system.
Part 1: General requirements.

EN 61439-1 (2011)

Low-voltage switchgear and control gear assemblies.
Part 1: General requirement.









APPLICATION EXAMPLES





ECOMOBILITY
GENERAL
CATALOGUE
2015-2016
PRODUCTS

3A TYPE CONNECTORS - SINGLE-PHASE 16 A 230 V~ 1P+N+PE+CP - IP44

| DESCRIPTION | PACK. | CODE | DESCRIPTION | PACK. | CODE |
|--|--------|------------|---|--------|------------|
|  Plug | 10/100 | 200.01633 |  Flush-mounting socket-outlet with flange 70x87 mm | 10/60 | 200.01663 |
|  Angled plug | 10/100 | 200.01633A |  Flush-mounting socket-outlet with interlock IP54 | 1/20 | 200.01663B |
|  Fixed plug with flange 70x87mm | 10/40 | 200.01693 |  Italian plug adaptor P17 | 10/100 | 200.01623 |
|  Straight outlet | 10/100 | 200.01643 |  French-German plug adaptor | 10/100 | 200.01624 |

DOMESTIC CONNECTORS - SINGLE-PHASE 16 A 230 V~ 1P+N+PE - MODE 1

| DESCRIPTION | PACK. | CODE | DESCRIPTION | PACK. | CODE |
|---|--------|-------------|--|-------|-----------|
|  UNEL IP54 flush-mounting socket-outlet with flange 70x87 mm (with switch) | 10/100 | 570.4062-SW |  UNEL IP54 flush-mounting socket-outlet with interlock | 1/10 | 200.4007B |

DOMOPLUS Series

For domestic use
IP66 with inserted plug



For additional information, please refer to our general catalogue





OMNIAPLUS Series

For domestic use
IP56 with inserted plug
with lock device



For additional information, please refer to our general catalogue

3C TYPE CONNECTORS - SINGLE/THREE-PHASE 16 A - 32 A 400 V~ 3P+N+PE+CP+PP - IP44







| | DESCRIPTION | PACK. | CODE | | DESCRIPTION | PACK. | CODE |
|---|--|-------|----------------|---|---|--------|--------------|
| | Plug with screw terminals 1.5 to 6 mm ² | 10/40 | 200.33233 | | Crimped pin kit 2.5 mm ² | 10/100 | 200.332KITC2 |
|  | Plug with crimped terminals 2.5 mm ² | 10/40 | 200.33233C2(*) |  | Crimped pin kit 4 mm ² | 10/100 | 200.332KITC4 |
| | Plug with crimped terminals 4 mm ² | 10/40 | 200.33233C4(*) | | Crimped pin kit 6 mm ² | 10/100 | 200.332KITC6 |
| | Plug with crimped terminals 6 mm ² | 10/40 | 200.33233C6(*) | | | | |
|  | Plug with crimped terminals 2.5 mm ² | 1 | 200.33234C2(*) |  | Flush-mounting socket-outlet with interlock IP54 | 1/20 | 200.33263B |
| | Plug with crimped terminals 4 mm ² | 1 | 200.33234C4(*) | | | | |
| | | | |  | Flush-mounting socket-outlet with flange 70x87 mm | 10/60 | 200.33263 |

(*) Cable to be defined at the time of the order.

TYPE 2 CONNECTORS - SINGLE/THREE-PHASE 16A - 32 A 400 V~ 3P+N+PE+CP+PP

| | DESCRIPTION | PACK. | CODE | | DESCRIPTION | PACK. | CODE |
|---|--|-------|------------|---|---|--------|-------------|
|  | Recessed socket-outlet with interlock system (plug and lid) IP54 without shutters IPXXB | 1/10 | 200.23264B |  | Standard lid IP55 for: 200.23266S 200.23266 | 12/120 | 200.23260CS |
| NEW  | Recessed socket-outlet with shutters IPXXD IP55 (mated) IP55 (with lid) | 1/12 | 200.23266S | NEW  | Compact lid IP55 for: 200.23266S 200.23266 200.23265 | 12/120 | 200.23260CC |
| NEW  | Recessed socket-outlet without shutters IPXXB IP55 (mated) IP55 (with lid) | 1/12 | 200.23266 | NEW  | Top plug locking with rotary activator and 2 switches for locking detection for: 200.23266S 200.23266 200.23265 | 12/120 | 200.23260BS |
| NEW  | Recessed socket-outlet without shutters IPXXB (compact version) IP54 (mated) IP55 (with lid) | 1/12 | 200.23265 | NEW  | Anti vandalic flange with interlock system (plug and lid) IP55 | 1/1 | 200.23260FA |

CORD SET (*)

| | PLUG | CABLE | CONNECTOR | PACK. | CODE |
|---|-----------------|-----------------------------------|-----------------|-------|--------------|
|  | Type 3A 16 A 1P | 3x2.5+1x0.5 mm ² - 5 m | Type 1 20 A 1P | 1/5 | 200.CS3A1T11 |
|  | Type 3A 16 A 1P | 3x2.5+1x0.5 mm ² - 5 m | Type 3A 16 A 1P | 1/5 | 200.CS3A13A1 |
|  | Type 3A 16 A 1P | 3x2.5+1x0.5 mm ² - 5 m | Type 2 20 A 1P | 1/5 | 200.CS3A1T21 |
|  | Type 3C 32 A 3P | 3x2.5+1x0.5 mm ² - 5 m | Type 1 20 A 1P | 1/5 | 200.CS3C1T11 |
| | Type 3C 32 A 3P | 3x6+1x0.5 mm ² - 5 m | Type 1 32 A 1P | 1/5 | 200.CS3C1T12 |
|  | Type 3C 32 A 3P | 5x2.5+1x0.5 mm ² - 5 m | Type 2 20 A 3P | 1/5 | 200.CS3C1T22 |
| | Type 3C 32 A 3P | 5x6+1x0.5 mm ² - 5 m | Type 2 32 A 3P | 1/5 | 200.CS3C1T24 |
|  | Type 2 20 A 1P | 3x2.5+1x0.5 mm ² - 5 m | Type 1 20 A 1P | 1/5 | 200.CST21T11 |
| | Type 2 32 A 1P | 3x6+1x0.5 mm ² - 5 m | Type 1 32 A 1P | 1/5 | 200.CST23T12 |
|  | Type 2 20 A 1P | 3x2.5+1x0.5 mm ² - 5 m | Type 2 20 A 1P | 1/5 | 200.CST21T21 |
| | Type 2 32 A 1P | 3x6+1x0.5 mm ² - 5 m | Type 2 32 A 1P | 1/5 | 200.CST23T23 |
| | Type 2 32 A 3P | 5x6+1+0.5 mm ² - 5 m | Type 2 32 A 3P | 1/5 | 200.CST24T24 |

(*) Special version available on request

Scame Solutions for charging systems:

1. single-family home



POWER SUPPLY AND ENERGY MANAGEMENT:

- connection to the distribution board in the flat;
- connection to an electrical board inside the garage;
- connection to a meter dedicated to power the charging station.

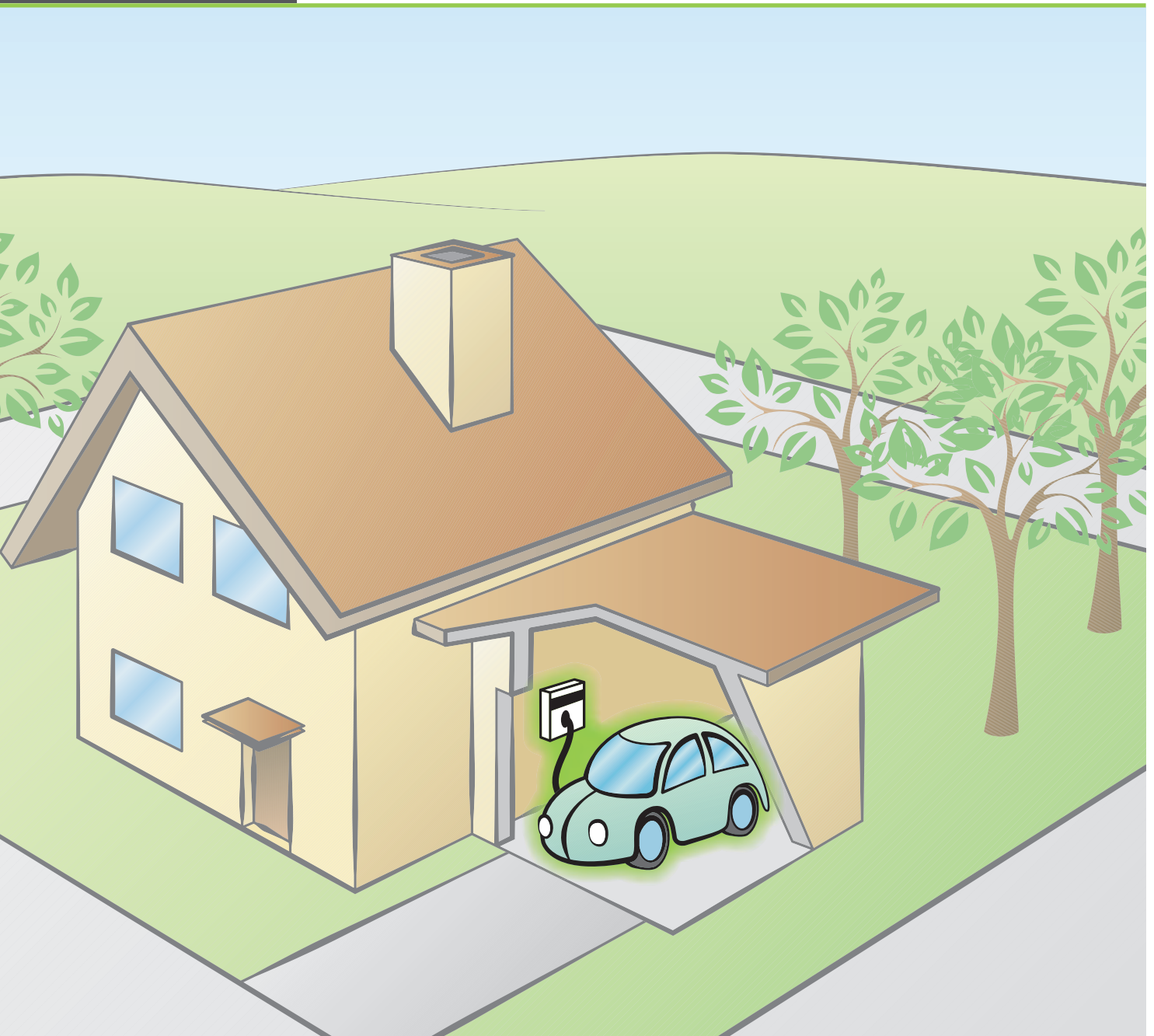

IN A PRIVATE GARAGE





UB-L CONSUMER UNIT WITHOUT RFID AND PROTECTIONS (*)

| DESCRIPTION | PACK. | CODE |
|--|-------|--------------|
|  No. 1 socket-outlet Type 3C – 3.5 kW | 1/1 | 204.UB11L-3C |
|  No. 1 socket-outlet Type 3A – 3.5 kW | 1/1 | 204.UB11L-3A |

WB-E WALL BOX WITHOUT RFID, PROTECTION AND ENERGY METERING (*)

| NEW | DESCRIPTION | PACK. | CODE |
|---|---|-------|---------------|
|  | No. 1 socket-outlet Type 3C – 3.5 kW | 1/1 | 204.WB11E-3C |
| | No. 1 socket-outlet Type 2 – 3.5 kW (▲) | 1/1 | 204.WB11E-T2 |
| | No. 1 socket-outlet Type 3A – 3.5 kW | 1/1 | 204.WB11E-3A |
|  | No. 1 cable+connector Type 1 – 3.5 kW | 1/1 | 204.WB11E-T11 |
| | No. 1 cable+connector Type 2 – 3.5 kW | 1/1 | 204.WB11E-T21 |

WB-L WALL BOX WITHOUT RFID AND PROTECTIONS (*)

| NEW | DESCRIPTION | PACK. | CODE |
|---|---|-------|----------------|
|  | No. 1 socket-outlet Type 3C – 3.5 kW | 1/1 | 204.WB11L-3C |
| | No. 1 socket-outlet Type 3C – 7 kW | 1/1 | 204.WB11L-3C32 |
| | No. 1 socket-outlet Type 2 – 3.5 kW (▲) | 1/1 | 204.WB11L-T2 |
| | No. 1 socket-outlet Type 2 – 7 kW | 1/1 | 204.WB11L-T232 |
| | No. 1 socket-outlet Type 3A – 3.5 kW | 1/1 | 204.WB11L-3A |
|  | No. 1 cable+connector Type 1 – 3.5 kW | 1/1 | 204.WB11L-T11 |
| | No. 1 cable+connector Type 1 – 7 kW | 1/1 | 204.WB11L-T12 |
| | No. 1 cable+connector Type 2 – 3.5 kW | 1/1 | 204.WB11L-T21 |
| | No. 1 cable+connector Type 2 – 7 kW | 1/1 | 204.WB11L-T23 |

(*) Special versions available on request.

(▲) With latching system.

2. Apartment buildings and parking lots

POWER SUPPLY AND ENERGY MANAGEMENT:

- connection to the existing electrical system for communal areas;
- connection to an individual electrical system;
- connection to an energy meter dedicated to EV charging;
- option to use an RFID badge;
- option to lock the socket-outlet cover.

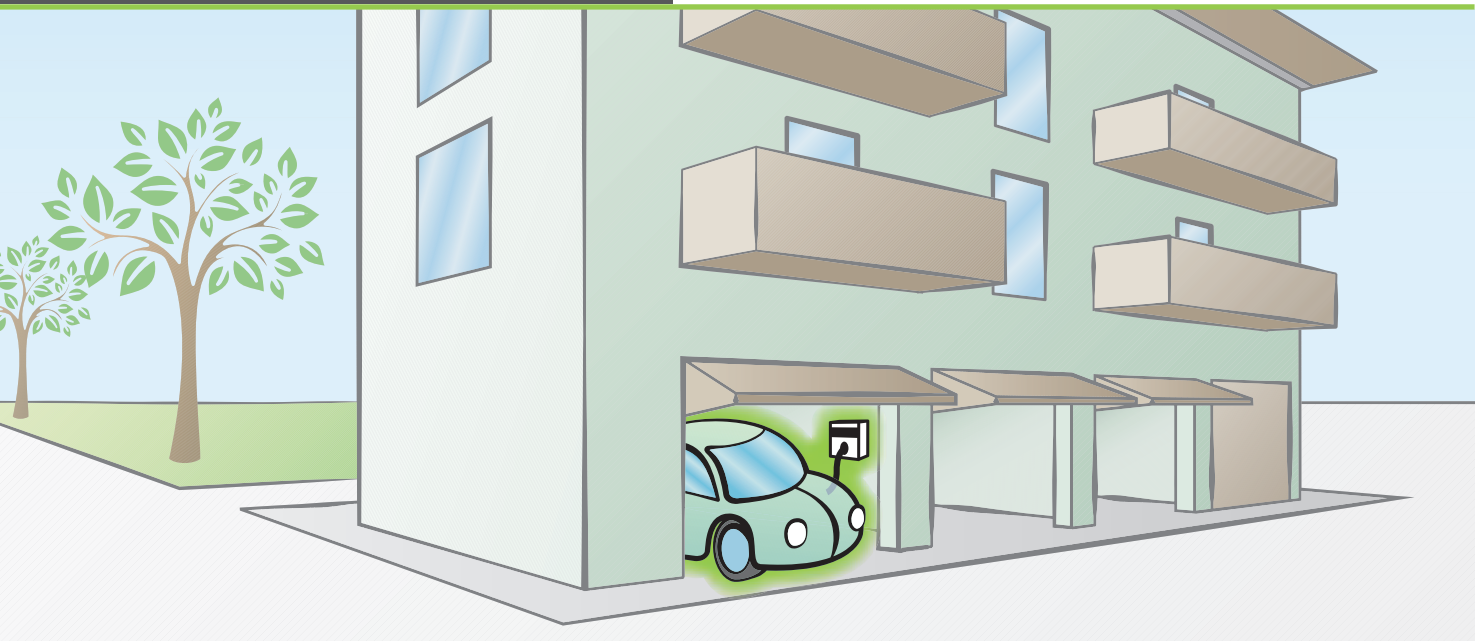

IN THE PRIVATE GARAGE OF A CONDOMINIUM





IN A CONDOMINIUM PARKING LOT



UB-R CONSUMER UNIT WITH RFID, PROTECTIONS AND ENERGY METER (*)

| NEW | DESCRIPTION | PACK. | CODE |
|---|--|-------|----------------|
|  | No. 1 socket-outlet type 3C with RFID – 3.5 kW | 1/1 | 204.UB11R-3C |
| | No. 1 socket-outlet type 3A with RFID – 3.5 kW | 1/1 | 204.UB11R-3A |
| | No. 1 socket-outlet UNEL with RFID – 3.5 kW | 1/1 | 204.UB11R-UN |
|  | No. 2 socket-outlets type 3C with RFID – 3.5 kW | 1/1 | 204.UB21R-3C3C |
| | No. 1 socket-outlet Type 3A with RFID - 3.5 kW No. 1 socket-outlet Type 3C with RFID - 3.5 kW | 1/1 | 204.UB21R-3C3A |
| | No. 1 socket-outlet Type 3C with RFID - 3.5 kW No. 1 socket-outlet UNEL with RFID - 3.5 kW | 1/1 | 204.UB21R-3CUN |
| | No. 2 socket-outlets Type 3A with RFID – 3.5 kW | 1/1 | 204.UB21R-3A3A |
| | No. 1 socket-outlet Type 3A with RFID - 3.5 kW No. 1 socket-outlet UNEL 3A with RFID - 3.5 kW | 1/1 | 204.UB21R-3AUN |
| | No. 2 socket-outlets UNEL with RFID- 3.5 kW | 1/1 | 204.UB21R-UNUN |

WB-P WALL BOX WITHOUT RFID, WITH PROTECTION, WITHOUT ENERGY METER

| NEW | DESCRIPTION | PACK. | CODE |
|---|---|-------|---------------|
|  | No. 1 socket-outlet Type 3C – 3.5 kW | 1/1 | 204.WB11P-3C |
| | No. 1 socket-outlet Type 2 – 3.5 kW (▲) | 1/1 | 204.WB11P-T2 |
| | No. 1 socket-outlet Type 3A – 3.5 kW | 1/1 | 204.WB11P-3A |
|  | No. 1 cable+connector Type 1 – 3.5 kW | 1/1 | 204.WB11P-T11 |
| | No. 1 cable+connector Type 2 – 3.5 kW | 1/1 | 204.WB11P-T21 |

WB-R WALL BOX WITH RFID, PROTECTIONS AND ENERGY METER (*)

| NEW | DESCRIPTION | PACK. | CODE |
|---|---|-------|----------------|
|  | No. 1 socket-outlet Type 3C with RFID – 3.5 kW | 1/1 | 204.WB11R-3C |
| | No. 1 socket-outlet Type 3C with RFID – 7 kW | 1/1 | 204.WB11R-3C32 |
| | No. 1 socket-outlet Type 2 with RFID – 3.5 kW (▲) | 1/1 | 204.WB11R-T2 |
| | No. 1 socket-outlet Type 2 with RFID – 7 kW (▲) | 1/1 | 204.WB11R-T232 |
| | No. 1 socket-outlet Type 3A with RFID – 3.5 kW | 1/1 | 204.WB11R-3A |
|  | No. 1 cable+connector Type 1 – 3.5 kW | 1/1 | 204.WB11R-T11 |
| | No. 1 cable+connector Type 1 – 7 kW | 1/1 | 204.WB11R-T12 |
| | No. 1 cable+connector Type 2 – 3.5 kW | 1/1 | 204.WB11R-T21 |
| | No. 1 cable+connector Type 2 – 7 kW | 1/1 | 204.WB11R-T23 |

(*) Special versions available on request.

(▲) With latching system.

3. Parking lots for collective use

Shopping centres, hotels, companies and public parking lots

POWER SUPPLY AND ENERGY MANAGEMENT:

- connection to the power distribution board at the facility;
- connection to an energy meter dedicated to EV charging;
- option to use an RFID badge;
- option to lock the socket-outlet cover;
- option to install a charging station management system via LAN network or WEB Server.

IN A COMPANY PARKING LOT

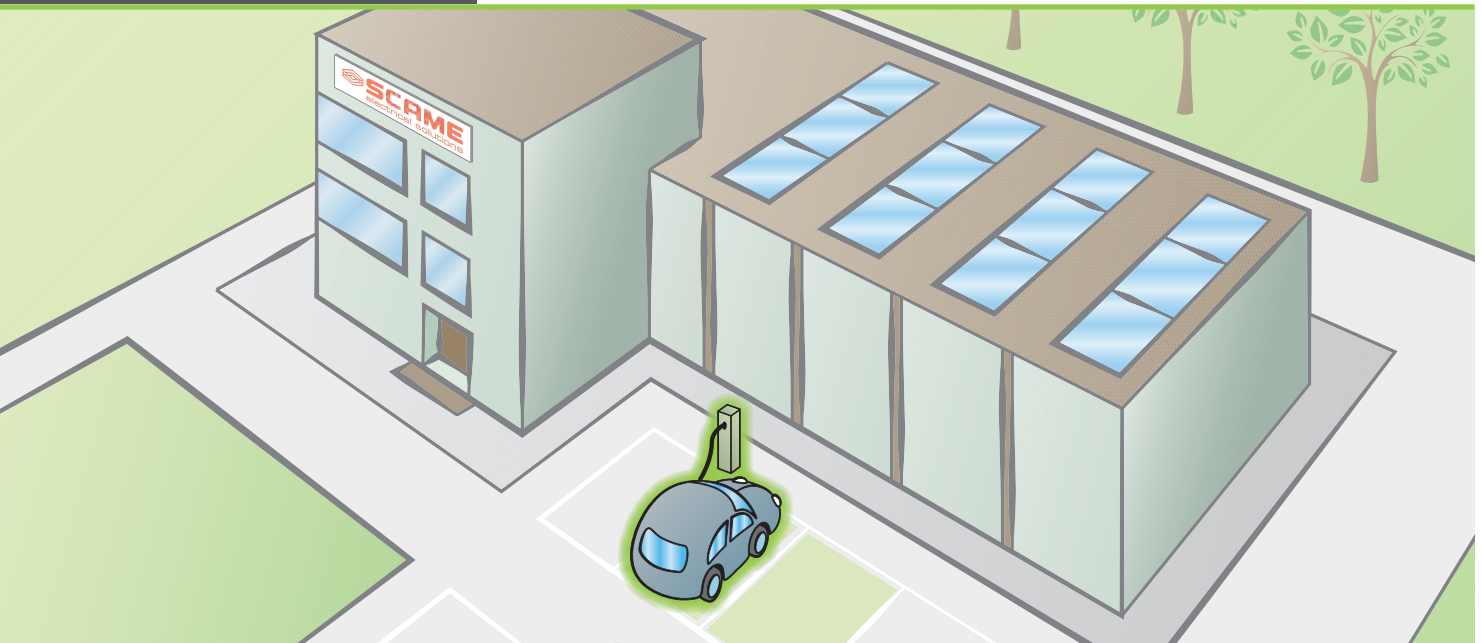

IN A PUBLIC PARKING GARAGE

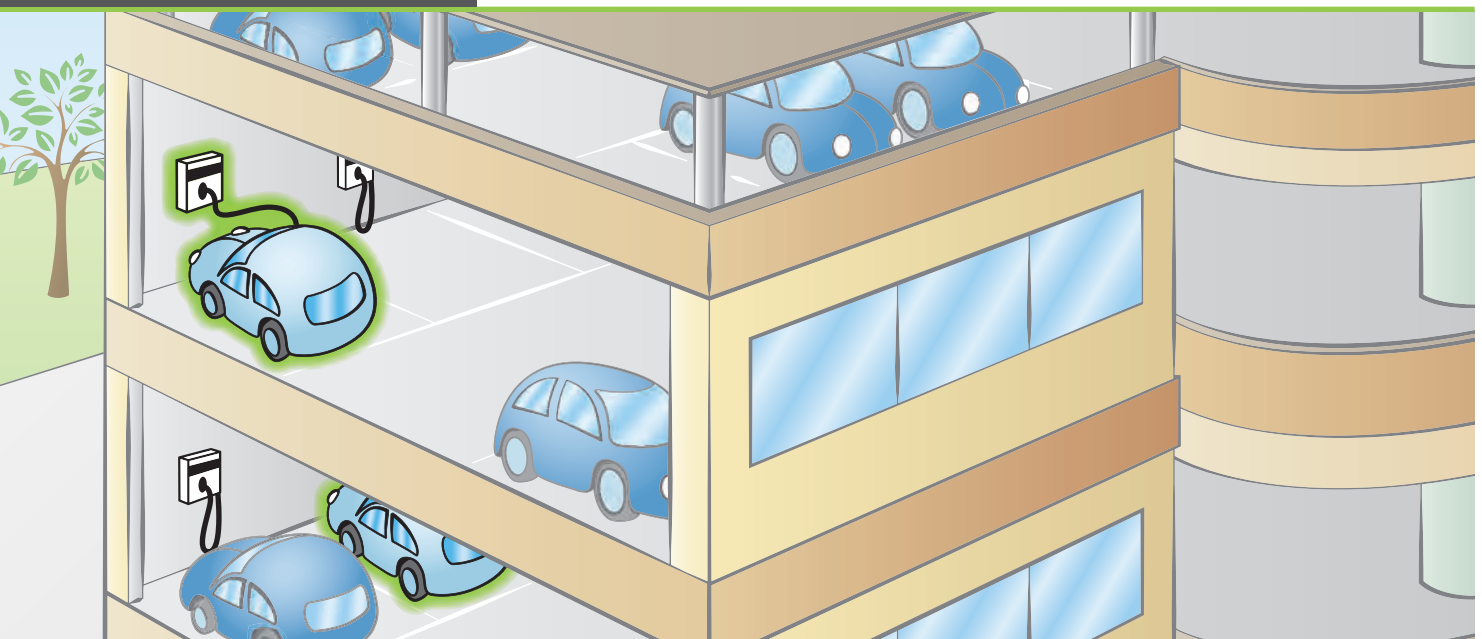

UB-B CONSUMER UNIT WITH RFID, PROTECTIONS, ENERGY METER AND INTERLOCK (*)

| | DESCRIPTION | PACK. | CODE |
|---|--|--------------|----------------|
|  | No. 1 socket-outlet Type 3C - 3.5 kW | 1/1 | 204.UB11B-3C |
| | No. 1 socket-outlet Type 3C - 7 kW type | 1/1 | 204.UB11B-3C32 |
| | No. 1 socket-outlet Type 3C - 22 kW | 1/1 | 204.UB13B-3C |
| | No. 1 socket-outlet Type 2 - 3.5 kW | 1/1 | 204.UB11B-T2 |
| | No. 1 socket-outlet Type 2 - 7 kW | 1/1 | 204.UB11B-T232 |
| | No. 1 socket-outlet Type 2 - 22 kW | 1/1 | 204.UB13B-T2 |
| | No. 1 socket-outlet Type 3A - 3.5 kW | 1/1 | 204.UB11B-3A |
| No. 1 socket-outlet UNEL – 3.5 kW | 1/1 | 204.UB11B-UN | |
|  | No. 2 socket-outlets Type 3C – 3.5 kW | 1/1 | 204.UB21B-3C3C |
| | No. 1 socket-outlet Type 3C – 3.5 kW No. 1 socket-outlet Type 3A – 3.5 kW | 1/1 | 204.UB21B-3C3A |
| | No. 2 socket-outlets Type 3A - 3.5 kW | 1/1 | 204.UB21B-3A3A |
|  | No. 1 socket-outlet Type 3C - 3.5 kW No. 1 socket-outlet UNEL - 3.5 kW | 1/1 | 204.UB21B-3CUN |
| | No. 1 socket-outlet Type 3A - 3.5 kW No. 1 socket-outlet UNEL - 3.5 kW | 1/1 | 204.UB21B-3AUN |
| | No. 2 socket-outlets UNEL – 3.5 kW | 1/1 | 204.UB21B-UNUN |

CB-B PILLAR IN STEEL WITH RFID, PROTECTIONS, ENERGY METER AND INTERLOCK (*)

| | DESCRIPTION | PACK. | CODE |
|---|--|-------|----------------|
|  | No. 2 socket-outlets Type 3C - 7 kW | 1/1 | 204.CB21B-3C3C |
| | No. 1 socket-outlet Type 3C - 7 kW No. 1 socket-outlet Type 2 - 7 kW type | 1/1 | 204.CB21B-3CT2 |
| | No. 2 socket-outlets Type 2 - 7 kW | 1/1 | 204.CB21B-T2T2 |
| | No. 1 socket-outlet Type 3C - 7 kW No. 1 socket-outlet Type 3A - 3.5 kW | 1/1 | 204.CB21B-3C3A |
| | No. 1 socket-outlet Type 2 - 7 kW No. 1 socket-outlet Type 3A - 3.5 kW | 1/1 | 204.CB21B-T23A |
| | No. 2 socket-outlets Type 3A - 3.5 kW | 1/1 | 204.CB21B-3A3A |

(*) Special versions available on request.

CA-B PILLAR IN PAINTED STEEL WITH RFID, PROTECTIONS, ENERGY METER AND INTERLOCK

| DESCRIPTION | PACK. | CODE |
|--|-------|------------------|
| No. 1 socket-outlet Type 3C - 7 kW | 1/1 | 204.CA11B-3C |
| No. 1 socket-outlet Type 3C - 22 kW | 1/1 | 204.CA13B-3C |
| No. 1 socket-outlet Type 2 - 7 kW | 1/1 | 204.CA11B-T2 |
| No. 1 socket-outlet Type 2 - 22 kW | 1/1 | 204.CA13B-T2 |
| No. 1 cable+connector Type 2 - 44 kW | 1/1 | 204.CA13R-T26 |
| No. 1 socket-outlet Type 3A - 3.5 kW | 1/1 | 204.CA11B-3A |
| No. 1 socket-outlet UNEL – 3.5 kW | 1/1 | 204.CA11B-UN |
| No. 2 socket-outlets Type 3C - 7 kW | 1/1 | 204.CA21B-3C3C |
| No. 1 socket-outlet Type 3C - 7 kW No. 1 socket-outlet Type 2 - 7 kW | 1/1 | 204.CA21B-3CT2 |
| No. 2 socket-outlets Type 2 - 7 kW | 1/1 | 204.CA21B-T2T2 |
| No. 1 socket-outlet Type 3C - 7 kW No. 1 socket-outlet Type 3A - 3.5 kW | 1/1 | 204.CA21B-3C3A |
| No. 1 socket-outlet Type 3C - 7 kW No. 1 socket-outlet UNEL - 3.5 kW | 1/1 | 204.CA21B-3CUN |
| No. 1 socket-outlet Type 2 - 7 kW No. 1 socket-outlet Type 3A - 3.5 kW | 1/1 | 204.CA21B-T23A |
| No. 1 socket-outlet Type 2 - 7 kW No. 1 socket-outlet UNEL - 3.5 kW | 1/1 | 204.CA21B-T2UN |
| No. 2 socket-outlets Type 3A - 3.5 kW | 1/1 | 204.CA21B-3A3A |
| No. 1 socket-outlet Type 3A - 3.5 kW No. 1 socket-outlet UNEL - 3.5 kW | 1/1 | 204.CA21B-3AUN |
| No. 2 socket-outlets UNEL – 3.5 kW | 1/1 | 204.CA21B-UNUN |
| No. 2 cable+connector Type 1- 3.5 kW | 1/1 | 204.CA21R-T11T11 |
| No. 2 cable+connector Type 2- 3.5 kW | 1/1 | 204.CA21R-T21T21 |
| No. 1 socket-outlet Type 3C - 22 kW No. 1 socket-outlet Type 3A - 3.5 kW | 1/1 | 204.CA22B-3C3A |
| No. 1 socket-outlet Type 3C - 22 kW No. 1 socket-outlet UNEL - 3.5 kW | 1/1 | 204.CA22B-3CUN |
| No. 1 socket-outlet Type 2 - 22 kW No. 1 socket-outlet Type 3A - 3.5 kW k | 1/1 | 204.CA22B-T23A |
| No. 1 socket-outlet Type 2 - 22 kW No. 1 socket-outlet UNEL - 3.5 kW | 1/1 | 204.CA22B-T2UN |
| No. 2 socket-outlets Type 3C - 22 kW | 1/1 | 204.CA23B-3C3C |
| No. 1 socket-outlet Type 3C - 22 kW No. 1 socket-outlet Type 2 - 22 kW | 1/1 | 204.CA23B-3CT2 |
| No. 2 socket-outlets Type 2 - 22 kW | 1/1 | 204.CA23B-T2T2 |
| No. 1 socket-outlet Type 3C - 7 kW No. 1 socket-outlet Type 2 - 7 kW No. 2 socket-outlets type 3A - 3.5 kW | 1/1 | 204.CA41B-001 |





CR-B PILLAR IN CORTEN STEEL WITH COIN, TOUCH PANEL, PROTECTIONS, ENERGY METER AND INTERLOCK (*)

| DESCRIPTION | PACK. | CODE |
|---|-------|---------------|
|  <p>No. 1 socket-outlet Type 3C – 7 kW No. 1 socket-outlet Type 2 – 7 kW No. 2 socket-outlets Type 3A – 3.5 kW</p> | 1/1 | 204.CR41B-001 |

CL-B PILLAR WITH COIN, RFID, PROTECTIONS, ENERGY METER AND INTERLOCK (*)

| DESCRIPTION | PACK. | CODE |
|---|-------|----------------|
|  <p>No. 1 socket-outlet Type 2 – 7 kW No. 1 socket-outlet Type 3A – 3.5 kW</p> | 1/1 | 204.CL21B-T23A |
| | 1/1 | 204.CL22B-T23A |

SYSTEM COMPONENTS

| DESCRIPTION | PACK. | CODE |
|---|-------|----------|
|  <p>Local server with standard management software</p> | 1/1 | 208.SERV |
|  <p>User card programmer with HF technology</p> | 1/1 | 208.PROG |
|  <p>User card with HF technology</p> | 1/10 | 208.CARD |

(*) Special versions available on request.

OTHER SOLUTIONS

CH - CHARGING COLUMN IN METAL SHEET CHADEMO

| | DESCRIPTION | PACK. | CODE |
|---|---------------------------------------|-------|--------------|
|  | No. 1 cable+connector CHAdeMO - 20 kW | 1/1 | 204.CH13L-20 |
| | No. 1 cable+connector CHAdeMO - 50 kW | 1/1 | 204.CH13L-50 |

MC - MOBILE CHARGING STATION

| | DESCRIPTION | PACK. | CODE |
|---|---|-------|--------------|
|  | No. 1 cable+connector CHAdeMO - 18.3 kW | 1/1 | 204.MC13L-CH |
| | No. 1 cable+connector COMBO2 - 20 kW | 1/1 | 204.MC13L-C2 |

CC - COMBINED CHARGING STATION

| | DESCRIPTION | PACK. | CODE |
|---|--|-------|------------------|
|  | No. 1 cable+connector CHAdeMO - 20 kW No. 1 socket-outlet Type 2 - 22 kW | 1/1 | 204.CC23L-CHT2 |
| | No. 1 cable+connector COMBO 2 - 20 kW No. 1 socket-outlet Type 2 - 22 kW | 1/1 | 204.CC23L-C2T2 |
| | No. 1 cable+connector CHAdeMO - 20 kW No. 1 cable+connector COMBO 2 - 20 kW No. 1 socket-outlet Type 2 - 22 kW | 1/1 | 204.CC33L-CHC2T2 |
| | Surface mounting plate | 1/1 | 204.CC-MP |
| | Collision protection pipe (spare) | 1/1 | 204.CC-CP |

EVOBIKE

| | DESCRIPTION | PACK. | CODE |
|---|---------------------------------------|-------|---------------|
|  | Bar to charge bicycles with 4 outlets | 1/1 | 204.EB41B-001 |
| | Pair of brackets for fixing to wall | 1/1 | 204.EB-ST |
| | Side pillar for fixing to ground | 1/1 | 204.EB-CL |
| | Central pillar for fixing to ground | 1/1 | 204.EB-CC |
| | Cable and bike charging kit | 1/1 | 204.EB-SP |

ACCESSORIES (*)

| DESCRIPTION | PACK. | CODE | |
|---|-----------------------|----------|------------|
|  Tubular support in galvanized steel | 1/1 | 654.0650 | |
|  Fixing plate in galvanized steel | UB21R | 1/4 | 654.0651 |
| | UB11L - UB11R | 1/4 | 654.0657 |
| | UB11B - UB13B - UB21B | 1/4 | 654.0652 |
|  Single-face hollow structure in painted steel sheet | UB11B - UB13B - UB21B | 1/1 | 204.DA5010 |

(*) For Domino Series assemblies

APPLICATION EXAMPLES

204.UB21R-3C3A +
654.0650 + 654.0651



654.0650

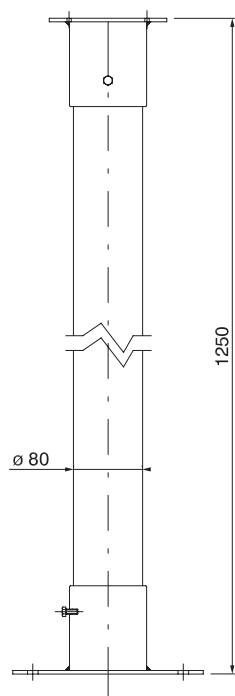

204.UB21B-3C3A +
204.DA5010



204.DA5010

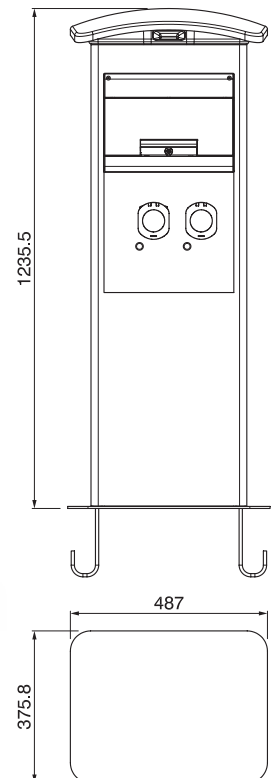

- Head with twilight-sensor LED light.
- Pre-assembled versions available upon request.

DIMENSIONS

200.01633

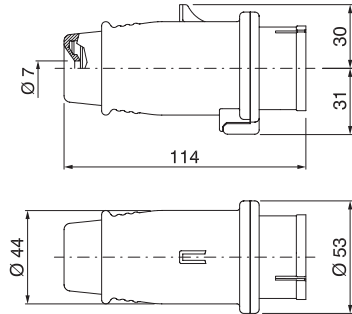

200.01633A

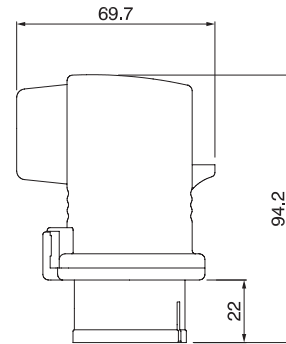

200.01693

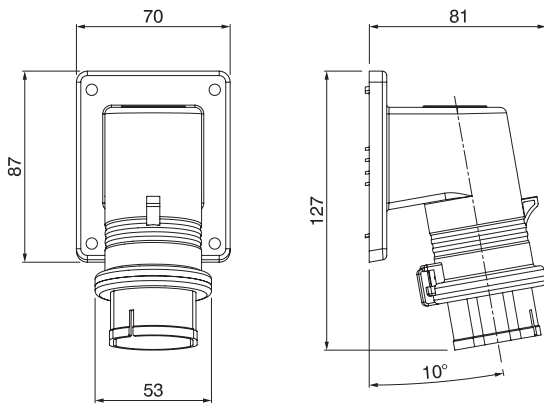

200.01643

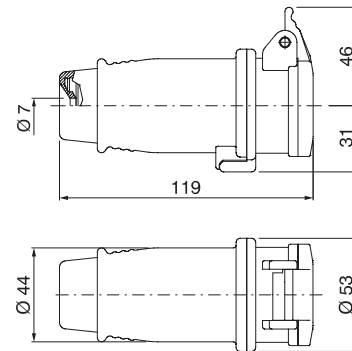

200.01663

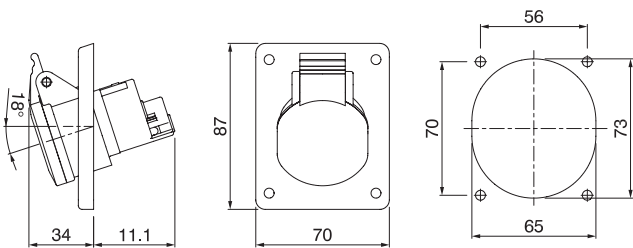

200.01663B

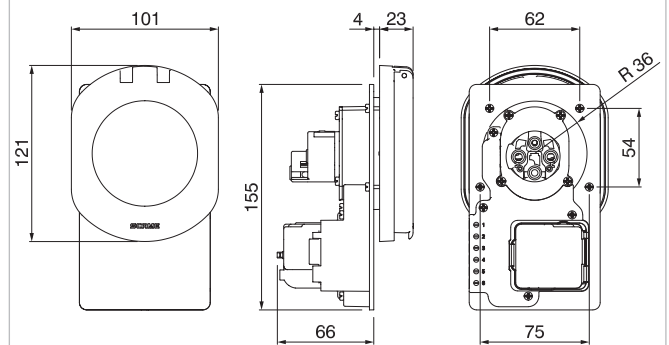

Dimensions in mm

DIMENSIONS

200.01623

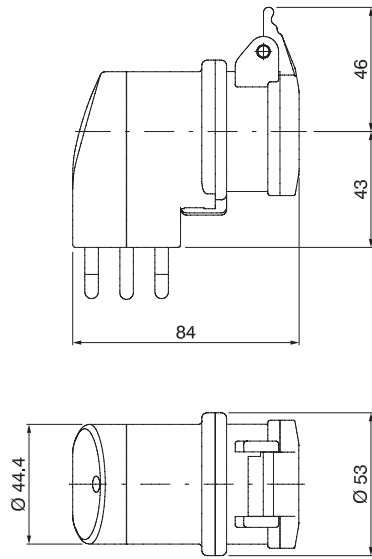

200.01624

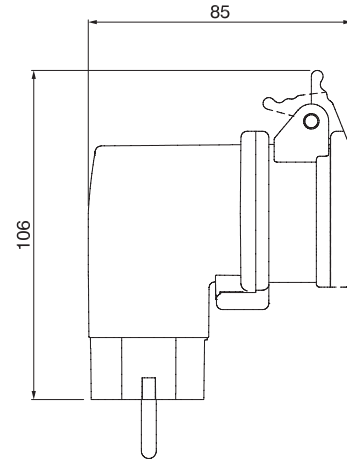

200.4007B

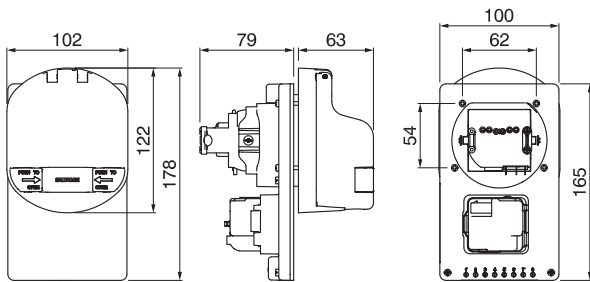

570.4062-SW

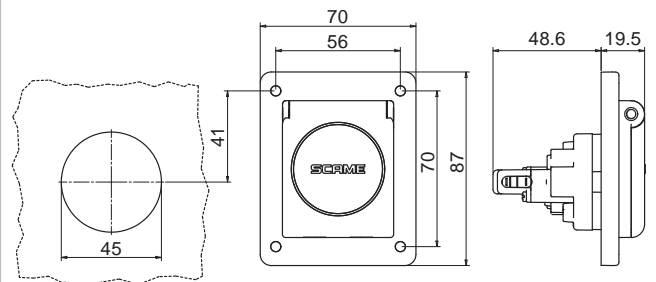

200.33233
 200.33233C2
 200.33233C4
 200.33233C6

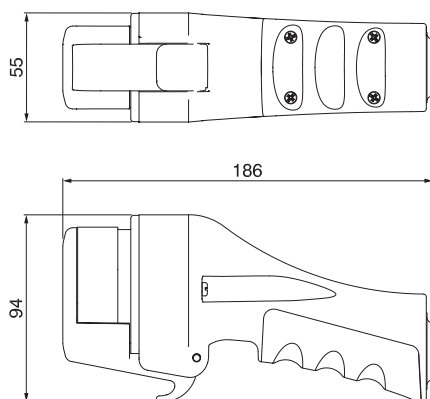

200.33234C2
 200.33234C4

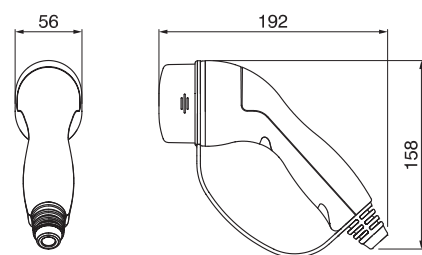

DIMENSIONS

200.33263

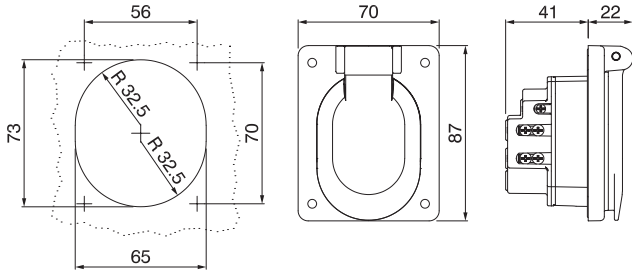

200.33263B

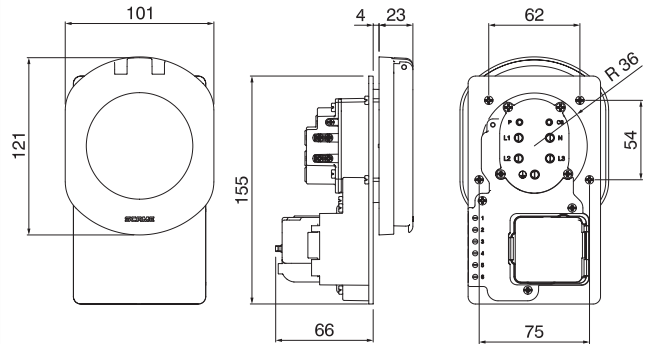

200.23264B

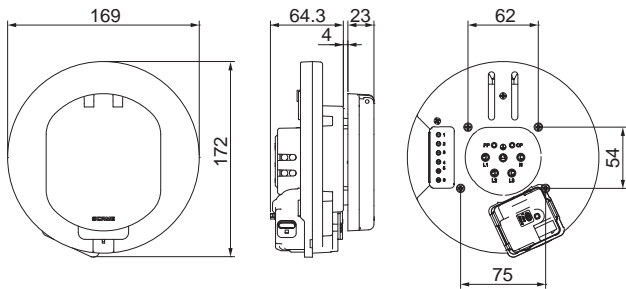

204.WB11L - 204.WB11E
204.WB11R - 204.WB11P

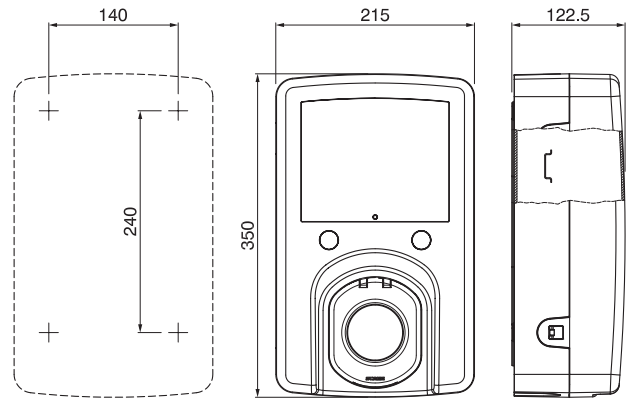

204.UB11L
204.UB11R

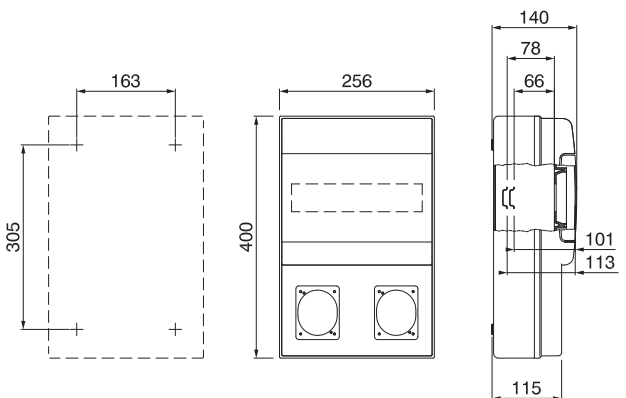

204.UB21R

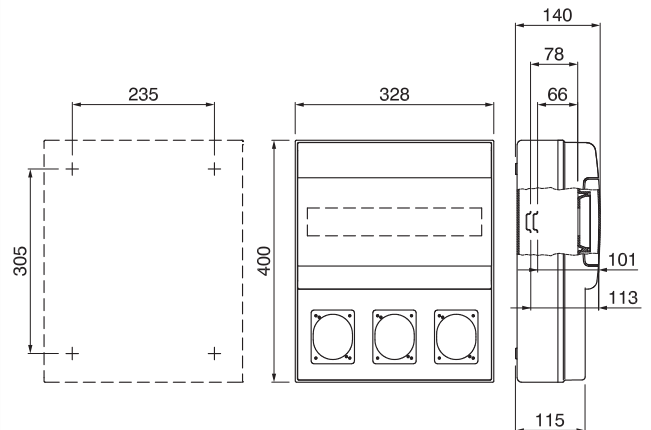

Dimensions in mm

DIMENSIONS

204.UB11B
 204.UB13B
 204.UB21B

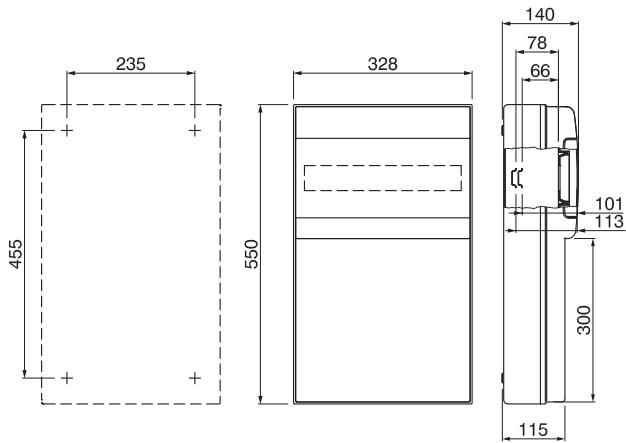

204.CR41B-001
 204.CL21B-T23A
 204.CL22B-T23A

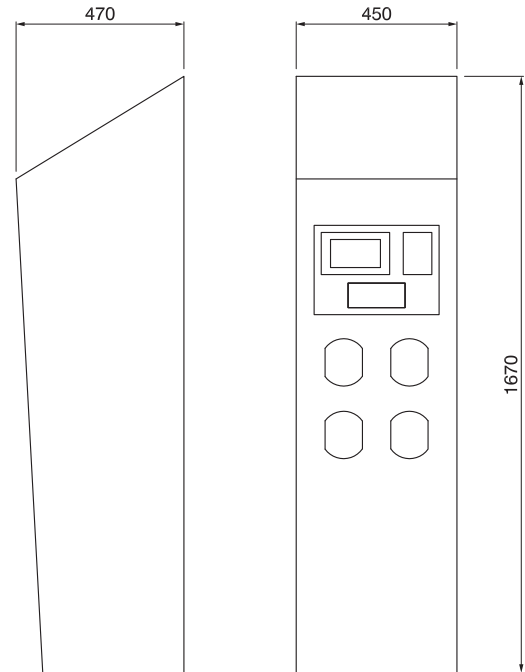

204.CA

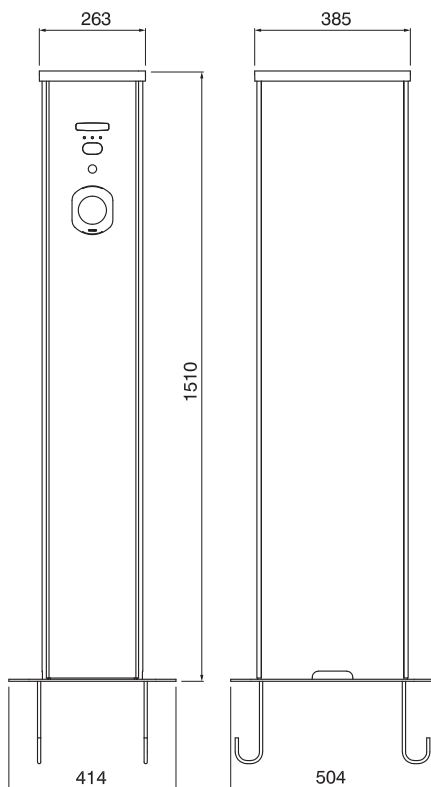

204.CB

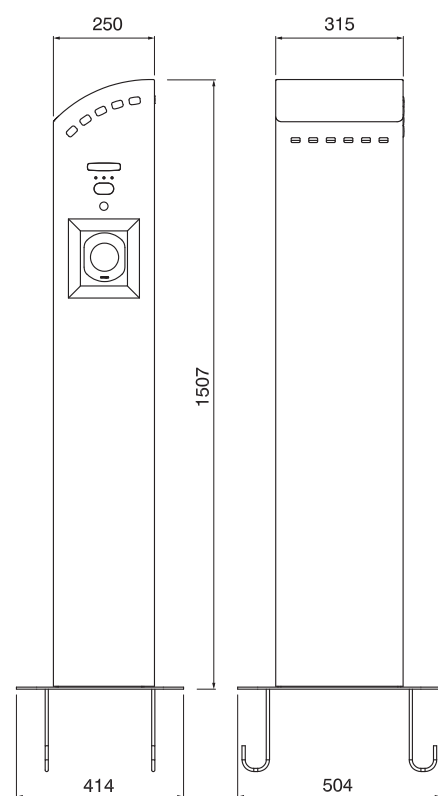

DIMENSIONS

204.MC13L-CH
204.MC13L-C2

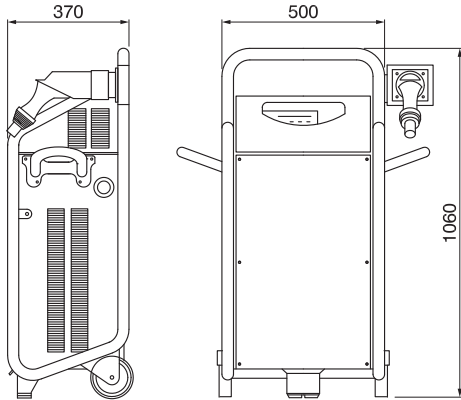

204.CC23L-CHT2
204.CC23L-C2T2
204.CC23L-CHC2T2

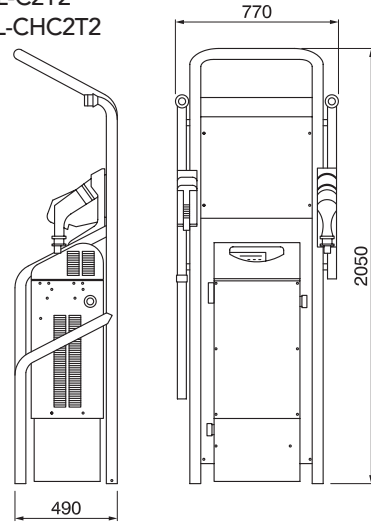

200.23266S - 200.23260BS
200.23266 - 200.23260BS

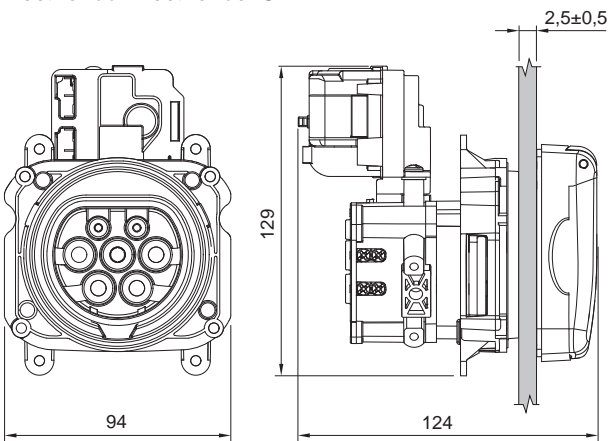

200.23265 - 200.23260BS

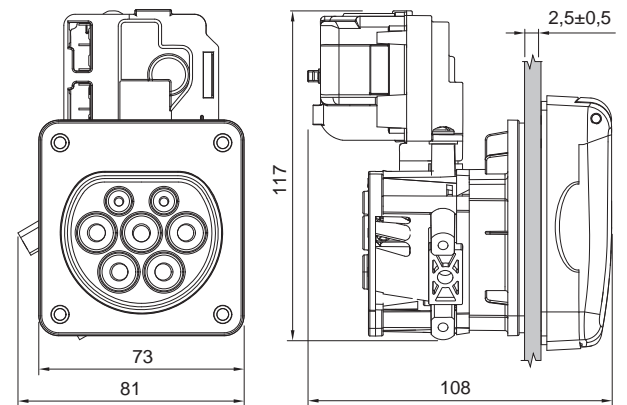

200.23260CS

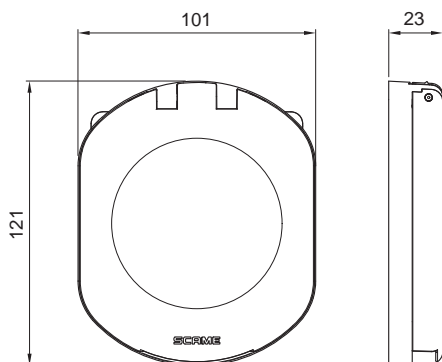

200.23260CC

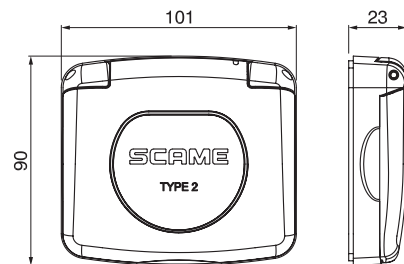

Dimensions in mm

DIMENSIONS

CHARGING PILLARS CA/CB

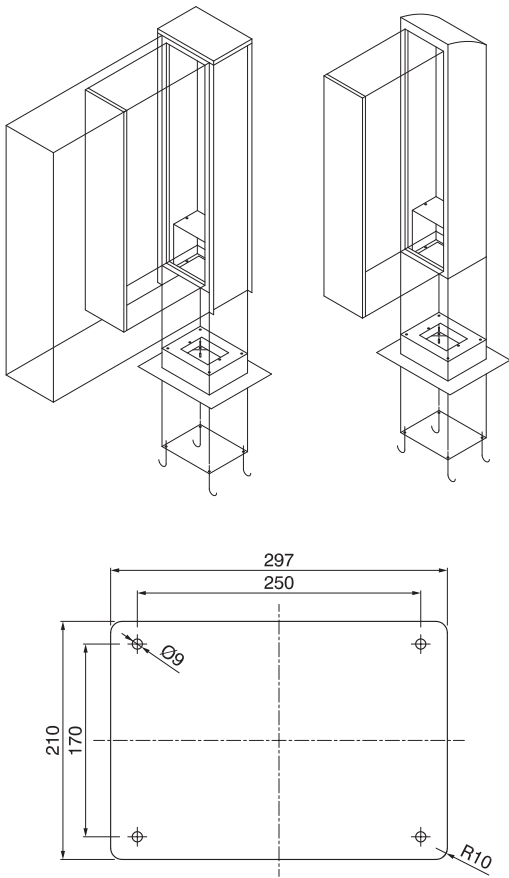

204.CH

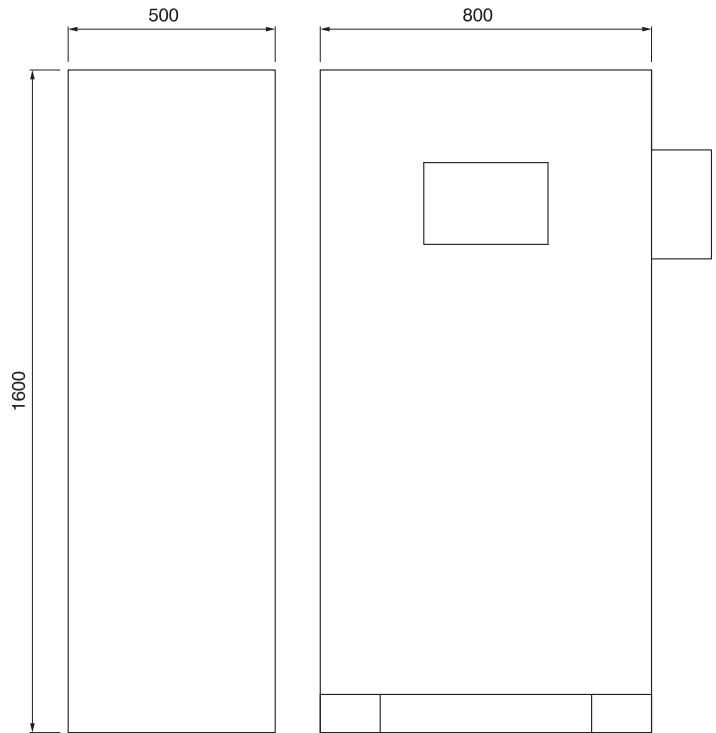

204.EB

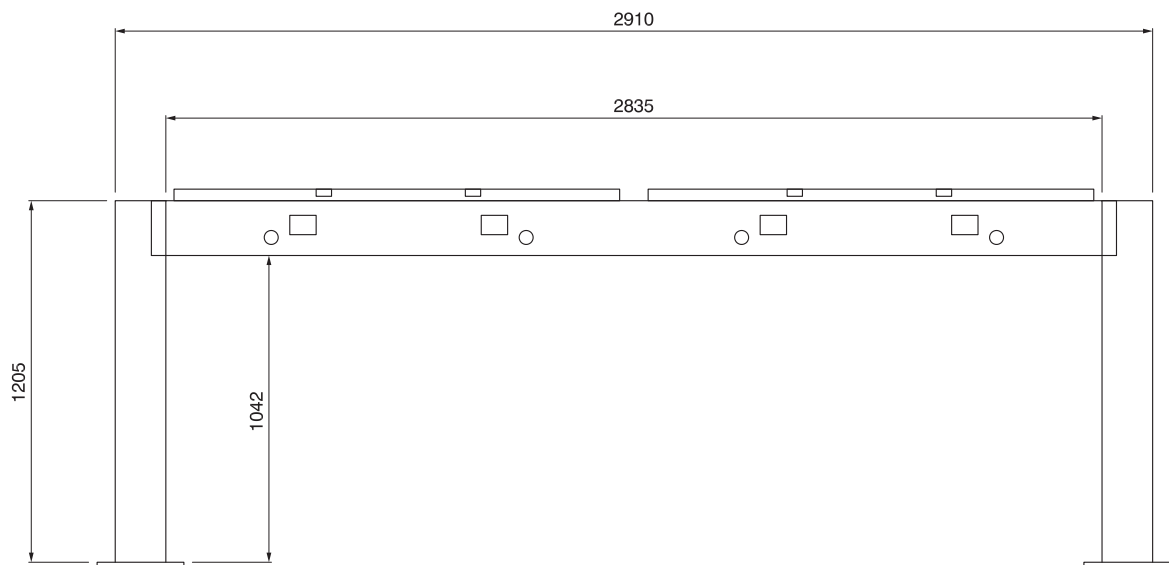

Index

| CODE | PAGE |
|----------------|------|
| 200.01623 | 37 |
| 200.01624 | 37 |
| 200.01633 | 37 |
| 200.01633A | 37 |
| 200.01643 | 37 |
| 200.01663 | 37 |
| 200.01663B | 37 |
| 200.01693 | 37 |
| 200.23260BS | 38 |
| 200.23260CC | 38 |
| 200.23260CS | 38 |
| 200.23260FA | 38 |
| 200.23264B | 38 |
| 200.23265 | 38 |
| 200.23266 | 38 |
| 200.23266S | 38 |
| 200.33233 | 38 |
| 200.33233C2 | 38 |
| 200.33233C4 | 38 |
| 200.33233C6 | 38 |
| 200.33234C2 | 38 |
| 200.33234C4 | 38 |
| 200.33263 | 38 |
| 200.33263B | 38 |
| 200.332KITC2 | 38 |
| 200.332KITC4 | 38 |
| 200.332KITC6 | 38 |
| 200.4007B | 37 |
| 200.CS3A13A1 | 39 |
| 200.CS3A1T11 | 39 |
| 200.CS3A1T21 | 39 |
| 200.CS3C1T11 | 39 |
| 200.CS3C1T12 | 39 |
| 200.CS3C1T22 | 39 |
| 200.CS3C1T24 | 39 |
| 200.CST21T11 | 39 |
| 200.CST21T21 | 39 |
| 200.CST23T12 | 39 |
| 200.CST23T23 | 39 |
| 200.CST24T24 | 39 |
| 204.CA11B-3A | 46 |
| 204.CA11B-3C | 46 |
| 204.CA11B-T2 | 46 |
| 204.CA11B-UN | 46 |
| 204.CA13B-3C | 46 |
| 204.CA13B-T2 | 46 |
| 204.CA13R-T26 | 46 |
| 204.CA21B-3A3A | 46 |
| 204.CA21B-3AUN | 46 |
| 204.CA21B-3C3A | 46 |
| 204.CA21B-3C3C | 46 |

| CODE | PAGE |
|------------------|------|
| 204.CA21B-3CT2 | 46 |
| 204.CA21B-3CUN | 46 |
| 204.CA21B-T23A | 46 |
| 204.CA21B-T2T2 | 46 |
| 204.CA21B-T2UN | 46 |
| 204.CA21B-UNUN | 46 |
| 204.CA21R-T11T11 | 46 |
| 204.CA21R-T21T21 | 46 |
| 204.CA22B-3C3A | 46 |
| 204.CA22B-3CUN | 46 |
| 204.CA22B-T23A | 46 |
| 204.CA22B-T2UN | 46 |
| 204.CA23B-3C3C | 46 |
| 204.CA23B-3CT2 | 46 |
| 204.CA23B-T2T2 | 46 |
| 204.CA41B-001 | 46 |
| 204.CB21B-3A3A | 45 |
| 204.CB21B-3C3A | 45 |
| 204.CB21B-3C3C | 45 |
| 204.CB21B-3CT2 | 45 |
| 204.CB21B-T23A | 45 |
| 204.CB21B-T2T2 | 45 |
| 204.CC23L-C2T2 | 48 |
| 204.CC23L-CHT2 | 48 |
| 204.CC33L-CHC2T2 | 48 |
| 204.CC-CP | 48 |
| 204.CC-MP | 48 |
| 204.CH13L-20 | 48 |
| 204.CH13L-50 | 48 |
| 204.CL21B-T23A | 47 |
| 204.CL22B-T23A | 47 |
| 204.CR41B-001 | 47 |
| 204.DA5010 | 49 |
| 204.EB41B-001 | 48 |
| 204.EB-CC | 48 |
| 204.EB-CL | 48 |
| 204.EB-SP | 48 |
| 204.EB-ST | 48 |
| 204.MC13L-C2 | 48 |
| 204.MC13L-CH | 48 |
| 204.UB11B-3A | 45 |
| 204.UB11B-3C | 45 |
| 204.UB11B-3C32 | 45 |
| 204.UB11B-T2 | 45 |
| 204.UB11B-T232 | 45 |
| 204.UB11B-UN | 45 |
| 204.UB11L-3A | 41 |
| 204.UB11L-3C | 41 |
| 204.UB11R-3A | 43 |
| 204.UB11R-3C | 43 |
| 204.UB11R-UN | 43 |

| CODE | PAGE |
|----------------|------|
| 204.UB13B-3C | 45 |
| 204.UB13B-T2 | 45 |
| 204.UB21B-3A3A | 45 |
| 204.UB21B-3AUN | 45 |
| 204.UB21B-3C3A | 45 |
| 204.UB21B-3C3C | 45 |
| 204.UB21B-3CUN | 45 |
| 204.UB21B-UNUN | 45 |
| 204.UB21R-3A3A | 43 |
| 204.UB21R-3AUN | 43 |
| 204.UB21R-3C3A | 43 |
| 204.UB21R-3C3C | 43 |
| 204.UB21R-3CUN | 43 |
| 204.UB21R-UNUN | 43 |
| 204.WB11E-3A | 41 |
| 204.WB11E-3C | 41 |
| 204.WB11E-T11 | 41 |
| 204.WB11E-T2 | 41 |
| 204.WB11E-T21 | 41 |
| 204.WB11L-3A | 41 |
| 204.WB11L-3C | 41 |
| 204.WB11L-3C32 | 41 |
| 204.WB11L-T11 | 41 |
| 204.WB11L-T12 | 41 |
| 204.WB11L-T2 | 41 |
| 204.WB11L-T21 | 41 |
| 204.WB11L-T23 | 41 |
| 204.WB11L-T232 | 41 |
| 204.WB11P-3A | 43 |
| 204.WB11P-3C | 43 |
| 204.WB11P-T11 | 43 |
| 204.WB11P-T2 | 43 |
| 204.WB11P-T21 | 43 |
| 204.WB11R-3A | 43 |
| 204.WB11R-3C | 43 |
| 204.WB11R-3C32 | 43 |
| 204.WB11R-T11 | 43 |
| 204.WB11R-T12 | 43 |
| 204.WB11R-T2 | 43 |
| 204.WB11R-T21 | 43 |
| 204.WB11R-T23 | 43 |
| 204.WB11R-T232 | 43 |
| 208.CARD | 47 |
| 208.PROG | 47 |
| 208.SERV | 47 |
| 570.4062-SW | 37 |
| 654.0650 | 49 |
| 654.0651 | 49 |
| 654.0652 | 49 |
| 654.0657 | 49 |



**We made history.
Now we're ready
to bring you into the future.**



LIBERA SERIES.
Connectors and recharging
stations for electric vehicles.

**EXPERIENCE BECOMES
INNOVATION.**



We were the first company in the 1990s to develop charging systems for electric vehicles, and we have never stopped innovating since then. We are now expanding the Libera Series with a range of connectors and charging stations that are even more advanced, complete and ergonomic. Safety remains the same as always with devices that protect against accidental contact with the live parts, but the power has been increased together with the functionality and ease of use. The LIBERA family is growing, while innovation marches on.



SCAME PARRE Spa - Via Costa Erta, 15 - 24020 Parre (Bg) Italy - Tel. 035.705000 - Fax 035.703122 - export@scame.com - www.scame.com

CUSTOMER SERVICE



InfoTECH

ITALY

Numero Verde
800-018009

WORLDWIDE

Scame **OnLine**
www.scame.com
infotech@scame.com

Scame technological partner
in this project:
www.in-presa.com
info@tagitalia.com

GENERALE SISTEMI SRL
VIA FRA I CAMPI, 13/C
59012 GALCIANA - PRATO - ITALY
TEL. +39 0574 816434
FAX +39 0574 815476



ScameOnLine
www.scame.com
ecomobility@scame.com

SCAME PARRE S.p.A.
VIA COSTA ERTA, 15
24020 PARRE (BG) ITALY
TEL. +39 035 705000
FAX +39 035 703122



@ScameMobility



Eco-Mobility-Scame-Parre

