

4 x M12 x 432 Anchor Bolts

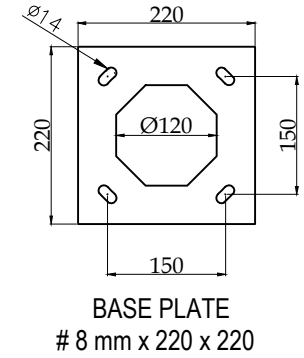

GENERAL NOTES / GENEL NOTLAR

* TÜM ÖLÇÜLER mm.DİR
* ALL DIMENSIONS ARE IN mm

* TÜM ÇELİK ELEMANLAR , ÇİVATA,SOMUN VE RONDELALAR SICAK DALDIRMA GALVANİZDİR (EN ISO 1461
* ALL STEEL ITEMS.BOLTS.NUTS & WASHERS TO BE HOT-DIPO GALVD.AS PER (EN ISO 1461)
* TASARIM KRİTELLERİNE GÖRE ÇİVATALAR (ISO 898) 5.8 & 6.8 & 8.8 OLARAK KULLANILABİLİR
* BOLTS CAN BE USED AS (ISO 898) 5.8 & 6.8 & 8.8 ACCORDING TO DESIGN CRITERIA

MATERIAL/MALAZEME

SAFT / GÖVDE	S235
FLANGE / FLANŞ	S235
OTHER ACCESSORIES / DİĞER AKSESUARLAR	S235

DESING/ HAZIRLAYAN	NAME/ İSİM	SING/ İMZA	DATE/ TARİH
DESING/ HAZIRLAYAN	E. AYGÜN		28/11/2017
DRAWN / ÇİZEN	E. AYGÜN		28/11/2017
CHECKED / KONTROL	E. AYGÜN		28/11/2017
APPROVED / ONAY	E. AYGÜN		28/11/2017

AD 60 ÖZEL AYDINLATMA DİREĞİ



DESIGN NOTES/ TASARIM NOTLARI	
DESING WIND SPED / TASARIM RÜZGAR HIZI	
FOCTOR OF SAFETY / GÜVENLİK KAT SAYISI	
DESIGN STANDART / TASARIM STANDARTI	

SİP/TEK NO	PAFTA NO
TARİH	28/11/2017
SHEET 1 OF 1	ÖLÇEK/ SCALE REV.

