

## DATA SHEET: STARTING TORQUE LIMITER – LAD3xx50



### TECHNICAL DATA

	LAD34150	LAD36250
Controlled	1 phase	1 phase
<b>MAIN CIRCUIT</b>		
Bypass	without B. AC-53a	without B. AC-53b
Load ratings	15A (AC 53a <sup>1)</sup> )	25A (AC 53b <sup>1)</sup> )
E.g.: max. nominal motor power (@ cos phi = 0,85)	8,8 kW (400 VAC) 10,5 kW (480 VAC)	17,5 kW (400 VAC) 21,0 kW (480 VAC)
Line voltage	208-240VAC (LAD34150) 400-480VAC (LAD34150) 550-600VAC (LAD36150)	208-240VAC (LAD34250) 400-480VAC (LAD34250) 550-600VAC (LAD36250)
Ramp-up	0,5 – 5 sec.	0,5 – 5 sec.
Ramp-down	–	–
Torque adjustment	0-85 % (of nominal torque)	0-85 % (of nominal torque)
Connection specification*	3-wires <sup>2)</sup>	3-wires <sup>2)</sup>
Modul width	45 mm	45mm (without Bypass)
Overload relay trip class	10: 8-3 <sup>1)</sup>	10: 8-3 <sup>1)</sup>
Max. leakage current	100-3000 (100% ramp up → 3000Starts/h)	100-3000 (100% ramp up → 3000Starts/h)
Min. operation current	5 mA	5 mA
Bypasscontactor (recommended)	50 mA	50 mA
Bypass	–	LSD23233

### THERMAL SPECIFICATIONS

Max. power dissipation	1 W/A	1 W (all in all)
Cooling method	Natural convection	Natural convection
Mounting	Max. +/- 30° vertical	Max. +/- 30° vertical
Operating temperature acc. to EN60947-4-2	-5° to +40°C	-5° to +40°C
Max. operating temperature	60°C (with current derating) <sup>3)</sup>	60°C (with current derating) <sup>3)</sup>
Storage temperature	-20° to +80°C	-20° to +80°C
Material housing	Self-extinguishing PPO UL94V1	Self-extinguishing PPO UL94V1
Material cooling element	Aluminium, black anodized	Aluminium, black anodized
Material mounting clip	Electroplated steel	Electroplated steel

## TECHNICAL DATA – continued

### GENERAL DATAS

Rated insulation voltage $U_i$	660 V	660 V
Impulse withstand voltage $U_{imp}$	4000 V	4000 V
Installation category	III	III
Degree of protection	IP20	IP20
Pollution degree	3	3

### AUXILIARY EQUIPMENT

Thermal overload	LAS UP62 (recommended for temperature-appli. more than 40°C)	LAS UP62 (recommended for temperature-appli. more than 40°C)
Auxiliary contact	LAH10050	LAH10050
Standards	cUL Std No. 508	cUL Std No. 508

<sup>1)</sup> AC-53a: Control of squirrel cage motors. It is not necessary to use a bypasscontactor.

AC-53b: Control of squirrel cage motors. It is necessary to use a bypasscontactor (see at description sample).

<sup>2)</sup> Connection:

3-phase configuration

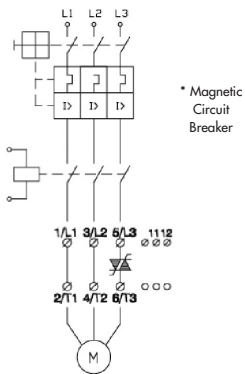

1-phase configuration

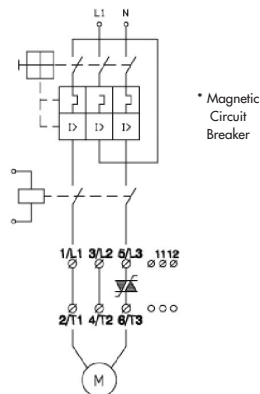

<sup>3)</sup> Operation in ambient temperatures exceeding 40°C is possible if the power dissipation is limited either by reducing the steady-state current or by reducing the duty-cycle of the soft starter as shown in the table. Max. Cycle time 15 min.

By 40°C	By 50°C	By 50°C
100% load Duty-cycle 100%	80% load Duty-cycle max. 0,8	70% load Duty-cycle max. 0,65

## CONNECTION SAMPLE

Connection diagram: For UP62 or other wiring purposes

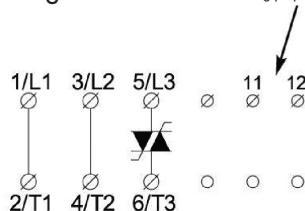

## ■ MOUNTING AND DIMENSIONS

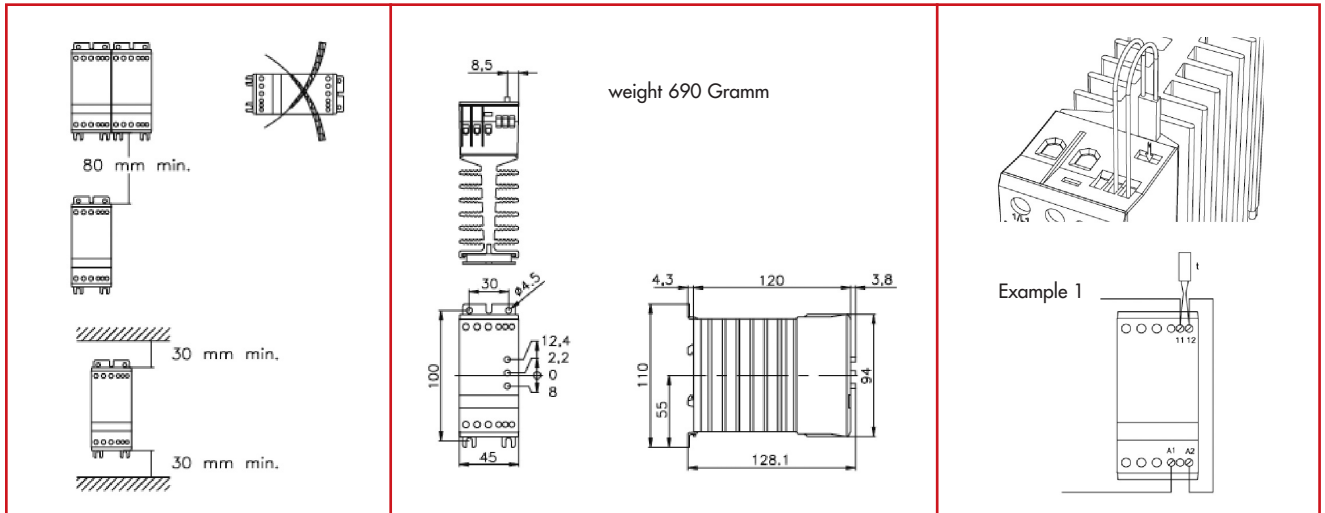

## ■ FUNCTIONAL DIAGRAM

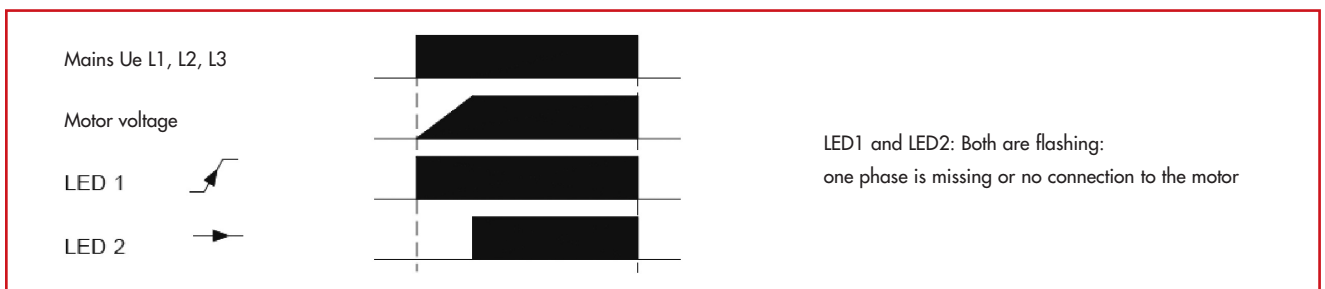

## ■ SHORT CIRCUIT PROTECTION

Short circuit protection with circuit breaker(a) or fuses(b):

2 types of short-circuit protection: Type 1: Short circuit protects the installation

Type 2: Short circuit protects the installation AND the semiconductors inside the motor controller

a) Short circuit protection with circuit breaker:

Co-ordination type 1 will be obtained when using magnetic circuit breakers or standard gI/GI fuses. Co-ordination type 2 will be obtained when using semiconductor fuses. When using semiconductor fuses the SCR will not be damaged due to transients and short circuits. The table indicates suitable fuses for co-ordination type 2 protection.

b) Short circuit protection with fuses:

Type 1 protection: fuse LAD3X150 v: max. 50AgI/gG

Type 2 protection: fuse LAD3X150 v: max. I<sub>t</sub> 1800A<sup>2</sup>s

Type 1 protection: fuse LAD3X250 v: max. 80AgI/gG

Type 2 protection: fuse LAD3X150 v: max. I<sub>t</sub> 6300A<sup>2</sup>s

## ■ DESCRIPTION SAMPLE

Overload relay trip class (EN60947-4-2):

e.g.: 25A: AC53a: 5-5: 100-120

25A: load rating (nominal current)

AC53a: Load specified with utilisation category

5-5: overload ability 5 x nominal current (5\*25A) for max. 5 sec. -> overload relay trip class 10A with min. requirement of 4 sec. valid (5 sec.)

100: continuous operation 100%

120: starts per hour

Minimum requirement acc. to EN60947-4-2:

10: 5 x nominal current: 8 sec.

10A: 5 x nominal current: 4 sec.

	Mindest-Zeitdauer der Überlastfestigkeit, T <sub>x</sub>						
	X = 8	X = 7	X = 6	X = 5	X = 4	X = 3	X = 2
5 <sup>a</sup>	0,4	0,5	0,7	1,0	1,5	1,7	6,1
10 A <sup>a</sup>	1,6	2	3	4	6	12	26
10 <sup>a</sup>	3	4	6	8	13	23	52
20 <sup>a</sup>	5	6	9	12	19	35	78
30 <sup>a</sup>	7	9	13	19	29	52	112

## WIRING CONNECTIONS

Wiring connections (Module 22.5 / 45 / 90 mm)										
Wiring type with or without cable / sleeves and other type of terminals * UL tested										
L1 T1 / L2 T2 / L3 T3 *M4 Power terminals	1 x 1,5 - 6 mm <sup>2</sup>	2 x 1,5 - 6 mm <sup>2</sup>	1 x 1,5 - 10 mm <sup>2</sup>	2 x 1,5 - 6 mm <sup>2</sup>	1 x 1 - 10 mm <sup>2</sup>	2 x 1 - 6 mm <sup>2</sup>	N.A.	Pozidrív 2 1,2 Nm Max.	6 mm 1,2 Nm Max.	
L1 T1 / L2 T2 / L3 T3 **M3 Power terminals	1 x 0,75 - 4 mm <sup>2</sup>	2 x 1,0 mm <sup>2</sup>	1 x 0,75 - 6 mm <sup>2</sup>	2 x 0,75 - 2,5 mm <sup>2</sup>	1 x 0,75 - 6 mm <sup>2</sup>	2 x 0,75 - 1,5 mm <sup>2</sup>	N.A.	Pozidrív 1 0,5 Nm Max.	4 mm 0,5 Nm Max.	
A1 A2 / I1 I2 Input terminals	1 x 0,5 - 1,5 mm <sup>2</sup>	2 x 0,5 - 0,75 mm <sup>2</sup>	1 x 0,5 - 1,5 mm <sup>2</sup>	2 x 0,5 - 1,5 mm <sup>2</sup>	1 x 0,5 - 1,5 mm <sup>2</sup>	2 x 0,5 - 1,5 mm <sup>2</sup>	N.A.	N.A.	3 mm 0,5 Nm Max.	
Wiring connections (Module 180 mm)										
Wiring type with or without cable / sleeves and other type of terminals										
L1 T1 / L2 T2 / L3 T3 *M6 Power terminals	1 x b4 - b35 mm <sup>2</sup>	2 x b2 - b16 mm <sup>2</sup>	1 x a4 - a35 mm <sup>2</sup>	2 x a4 - a10 mm <sup>2</sup>	1 x a4 - b50 mm <sup>2</sup>	2 x b4 - b16 mm <sup>2</sup>	N.A.	Pozidrív 3 4,0 Nm* 5,5 Nm* Max.	N.A.	
<b>*Important: When using electric or pneumatic tools for screw terminals observe the maximum torque limits</b>										

## ADJUSTMENT OF TIME AND TORQUE

### Step 1: ramp-up and torque:

- 1.1) Set the Ramp-Up switch to maximum
- 1.2) Decrease the Ram-Up time until desired start is achieved
- 1.3) Set the Initial Torque switch to minimum
- 1.4) Switch the contactor ON for a short time. If the load does not rotate immediately increment the Initial Torque and try again. Repeat until the load starts to rotate immediately on start-up

