

DATA SHEET: 2 PHASES SOFTSTARTER – LAK34x55



TECHNICAL DATA

	LAK34155	LAK34255
Controlled	2 phases	2 phases

MAIN CIRCUIT

	LAK34155	LAK34255
Bypass	without B. AC-53a	with B. AC-53b
Load ratings	15A (AC 53a ¹⁾)	25A (AC 53b ¹⁾)
E.g.: max. nominal motor power (@ cos phi = 0,85)	8,8 kW (400 VAC) 10,5 kW (480 VAC)	14,7 kW (400 VAC) 17,6 kW (480 VAC)
Line voltage	400-480 VAC	400-480 VAC
Ramp-up	0,5 – 10 sec.	0,5 – 10 sec.
Ramp-down	0,5 – 10 sec.	0,5 – 10 sec.
Torque adjustment	0-85 % (of nominal torque)	0-85 % (of nominal torque)
Connection specification*	3-wires ²⁾	3-wires ²⁾
Modul width	45 mm	90mm
Overload relay trip class	10 A: 8-3 ¹⁾	10 A: 8-3 ¹⁾
Max. leakage current	5 mA	5 mA
Mindestlaststrom	50 mA	50 mA

CONTROL CIRCUIT

	LAK34155	LAK34255
Control voltage	24-480 VAC/DC	24-480 VAC/DC
Pick-up voltage max. VAC/DC	20,4 -253/528 V	20,4 -253/528 V
Max. current for no operation	1 mA	1 mA
Max. response time	70 msec.	70 msec.
Max. current/power	15 mA / 2 VA	15 mA / 2 VA

THERMAL SPECIFICATIONS

	LAK34155	LAK34255
Max. power dissipation	2 W/A	2 W/A
Cooling method	Natural convection	Natural convection
Mounting	Max. +/- 30° vertical	Max. +/- 30° vertical
Operating temperature acc. to EN60947-4-2	-5° to +40°C	-5° to +40°C
Max. operating temperature	60°C (with current derating) ³⁾	60°C (with current derating) ³⁾
Storage temperature	-20° to +80°C	-20° to +80°C
Material housing	Self-extinguishing PPO UL94V1	Self-extinguishing PPO UL94V1
Material cooling element	Aluminium, black anodized	Aluminium, black anodized
Material mounting clip	Electroplated steel	Electroplated steel

TECHNICAL DATA – continued

GENERAL DATAS

Rated insulation voltage U_i	660 V	660 V
Impulse withstand voltage U_{imp}	4000 V	4000 V
Installation category	III	III
Degree of protection	IP20	IP20
Pollution degree	3	3

AUXILIARY EQUIPMENT

Thermal overload	LAS UP62 (recommended for temperature-appli. more than 40°C)	LAS UP62 (recommended for temperature-appli. more than 40°C)
Auxiliary contact	LAH10050	LAH10050
Standards	cUL Std No. 508	cUL Std No. 508

- ¹⁾ AC-53a: Control of squirrel cage motors. It is not necessary to use a bypasscontactor.
AC-53b: Control of squirrel cage motors. It is necessary to use a bypasscontactor (see at description sample).

- ²⁾ Connection: 3-wires

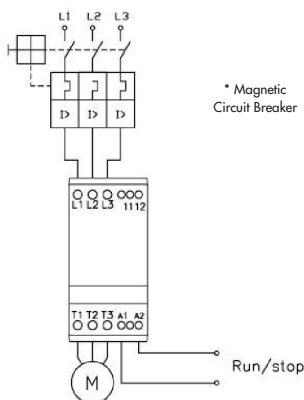

- ³⁾ Operation in ambient temperatures exceeding 40°C is possible if the power dissipation is limited either by reducing the steady-state current or by reducing the duty-cycle of the soft starter as shown in the table. Max. Cycle time 15 min.

By 40°C	By 50°C	By 50°C
100% load Duty-cycle 100%	80% load Duty-cycle max. 0,8	70% load Duty-cycle max. 0,65

CONNECTION SAMPLE

Connection diagram:

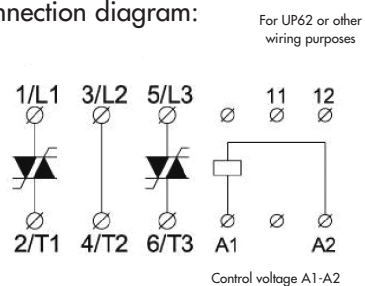

MOUNTING AND DIMENSIONS

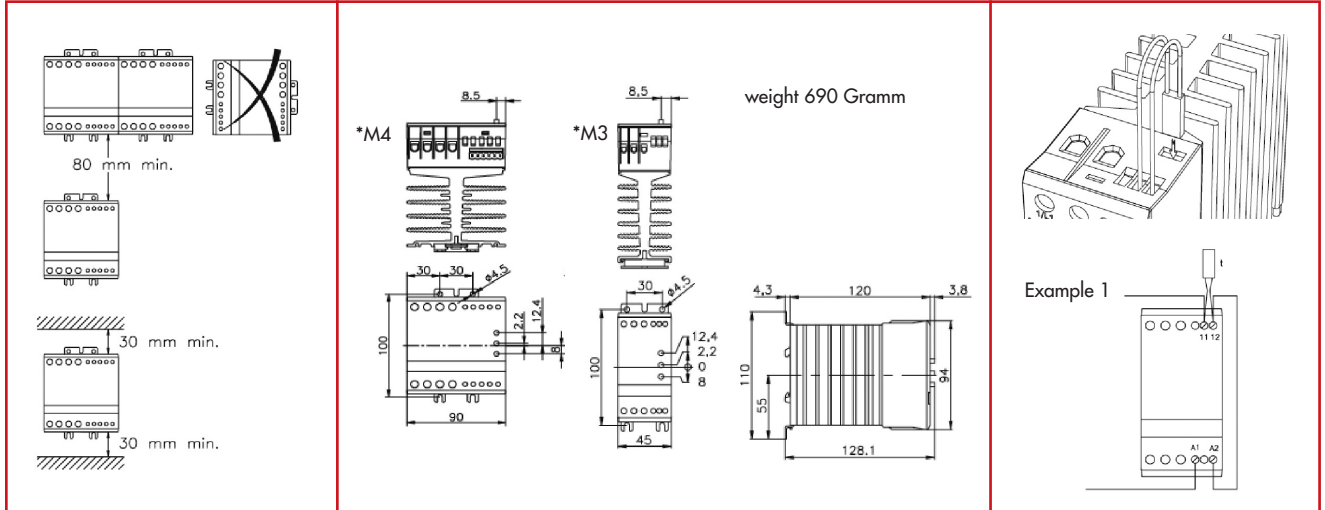

FUNCTIONAL DIAGRAM

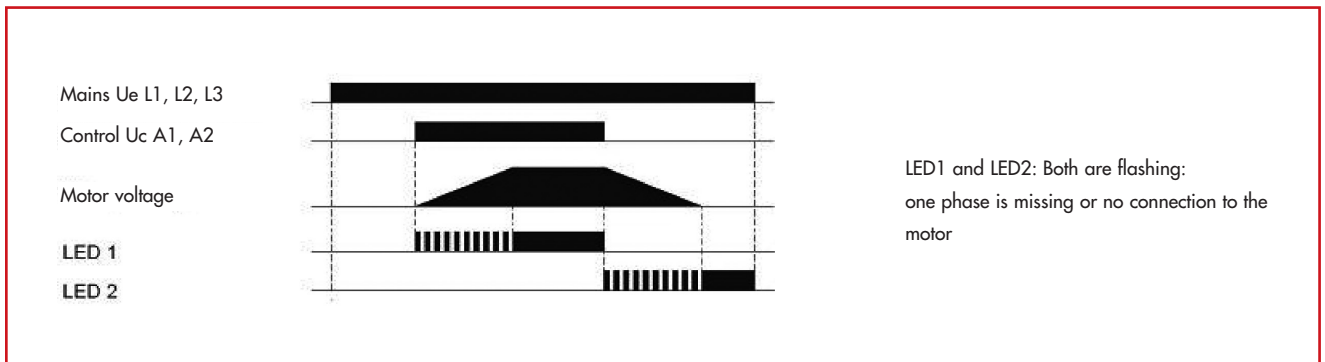

SHORT CIRCUIT PROTECTION

Short circuit protection with circuit breaker(a) or fuses(b):

2 types of short-circuit protection: Type 1: Short circuit protects the installation

Type 2: Short circuit protects the installation AND the semiconductors inside the motor controller

a) Short circuit protection with circuit breaker: Type 2 Protection by fuses with appropriated I²t

b) Short circuit protection with fuses:

Type 1 protection: fuse LAK34155 v: max. 50AgL/gG

Type 2 protection: fuse LAK34155 v: max. I²t 1800A²s

Type 1 protection: fuse LAK34255 v: max. 80AgL/gG

Type 2 protection: fuse LAK34255 v: max. I²t 6300A²s

DESCRIPTION SAMPLE

Overload relay trip class (EN60947-4-2):
e.g.: 25A: AC53a: 5-5: 100-120

25A: load rating (nominal current)

AC53a: Load specified with utilisation category

5-5: overload ability 5 x nominal current (5*25A) for max. 5 sec. ->
overload relay trip class 10A with min. requirement of 4 sec. valid (5 sec.)

100: continuous operation 100%

120: starts per hour

Minimum requirement acc. to EN60947-4-2:

10: 5 x nominal current: 8 sec.

10A: 5 x nominal current: 4 sec.

	Mindest-Zeitdauer der Überlastfestigkeit, T _u						
	X=8	X=7	X=6	X=5	X=4	X=3	X=2
5 ^a	0,4	0,5	0,7	1,0	1,5	1,7	6,1
10 A ^a	1,6	2	3	4	6	12	26
10 ^a	3	4	6	8	13	23	52
20 ^a	5	6	9	12	19	35	78
30 ^a	7	9	13	19	29	52	112

WIRING CONNECTIONS

Wiring connections (Module 22.5 / 45 / 90 mm)										
Wiring type with or without cable / sleeves and other type of terminals * UL tested										
L1 T1 / L2 T2 / L3 T3 *M4 Power terminals	1 x 1,5 - 6 mm ²	2 x 1,5 - 6 mm ²	1 x 1,5 - 10 mm ²	2 x 1,5 - 6 mm ²	1 x 1 - 10 mm ²	2 x 1 - 6 mm ²	N.A.	Pozidrív 2 1.2 Nm Max.	6 mm 1,2 Nm Max.	
L1 T1 / L2 T2 / L3 T3 **M3 Power terminals	1 x 0,75 - 4 mm ²	2 x 1.0 mm ²	1 x 0,75 - 6 mm ²	2 x 0,75 - 2.5 mm ²	1 x 0,75 - 6 mm ²	2 x 0,75 - 1.5 mm ²	N.A.	Pozidrív 1 0.5 Nm Max.	4 mm 0,5 Nm Max.	
A1 A2 / I1 I2 Input terminals	1 x 0,5 - 1,5 mm ²	2 x 0,5 - 0,75 mm ²	1 x 0,5 - 1,5 mm ²	2 x 0,5 - 1,5 mm ²	1 x 0,5 - 1,5 mm ²	2 x 0,5 - 1,5 mm ²	N.A.	N.A.	3 mm 0,5 Nm Max.	
Wiring connections (Module 180 mm)										
Wiring type with or without cable / sleeves and other type of terminals										
L1 T1 / L2 T2 / L3 T3 *M6 Power terminals	1 x b4 - b35 mm ²	2 x b2 - b16 mm ²	1 x a4 - a35 mm ²	2 x a4 - a10 mm ²	1 x a4 - b50 mm ²	2 x b4 - b16 mm ²	N.A.	Pozidrív 3 4.0 Nm* 5.5 Nm* Max.	N.A.	
*Important: When using electric or pneumatic tools for screw terminals observe the maximum torque limits										

ADJUSTMENT OF TIME AND TORQUE

Step 1: Ramp-up and torque:

- 1.1) Set the Ramp-Up switch to maximum
- 1.2) Set the Ramp-Down switch to minimum.
- 1.3) Set the Initial Torque switch to minimum.
- 1.4) Apply control signal for a few seconds. If the load does not rotate immediately increment the Initial Torque and try again. Repeat until the load starts to rotate immediately on start-up.
- 1.5) Adjust Ramp-Up time to the estimated start time (scale is in seconds) and start the motor.
- 1.6) Decrease the Ram-Up time until mechanical surge is observed during start.
- 1.7) Increase the time one step to eliminate the surge.

Step 2 (optional): Kick Start Einstellung: If it is not possible to reach a time sufficient for the application (step A7) it may be necessary to kick-start the load.)

- 2.1) Set the Ramp-Up switch to maximum.
- 2.2) Set the Ramp-Down switch to minimum.
- 2.3) Set the Initial Torque switch to minimum Kick-start torque.

Step 3: ramp down:

Follow procedure Step1 or Step2 to set Ramp-Up and initial torque:

- 3.1) Set the Ramp-Down switch to maximum.
- 3.2) Switch off the control voltage and observe any mechanical surges on the load. If none decrement Ramp-Down switch and try again. Repeat until mechanical surges on the load is observed.
- 3.3) Increase the time one step to eliminate the surge.

