

DATA SHEET:
TURNING BOLT FOR HALF CYLINDER

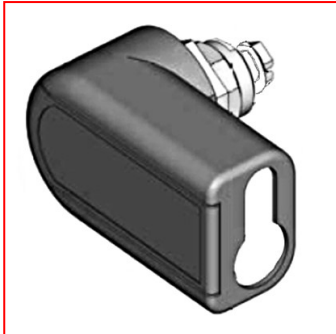

IU001925--

SCHRACK-INFO

- Suitable for all WSM and Minipol enclosures with sash fastener (hole picture 22.5 mm)
- Housing made of Zinc die-casting (GD-Zn), Handle made of polyamide GF black, Earthing nut and screws are galvanized, with spring and gasket
- Shock resistant and vibration proof with profile half cylinder according to DIN 18252 (EN 1303)
- Degree of protection: IP65
- Half cylinder is not included in delivery

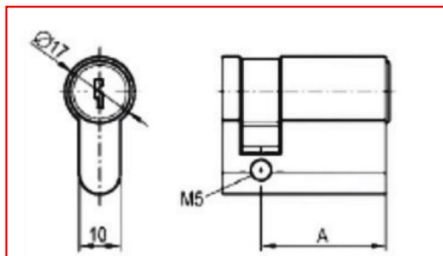

Profile half cylinder according to DIN 18252 (EN 1303)
Dimension "A" = 30 mm corresponds to the total length 40 mm

The closing thumb must be located between 3 and 5 o'clock.

DIMENSIONS IU001925--

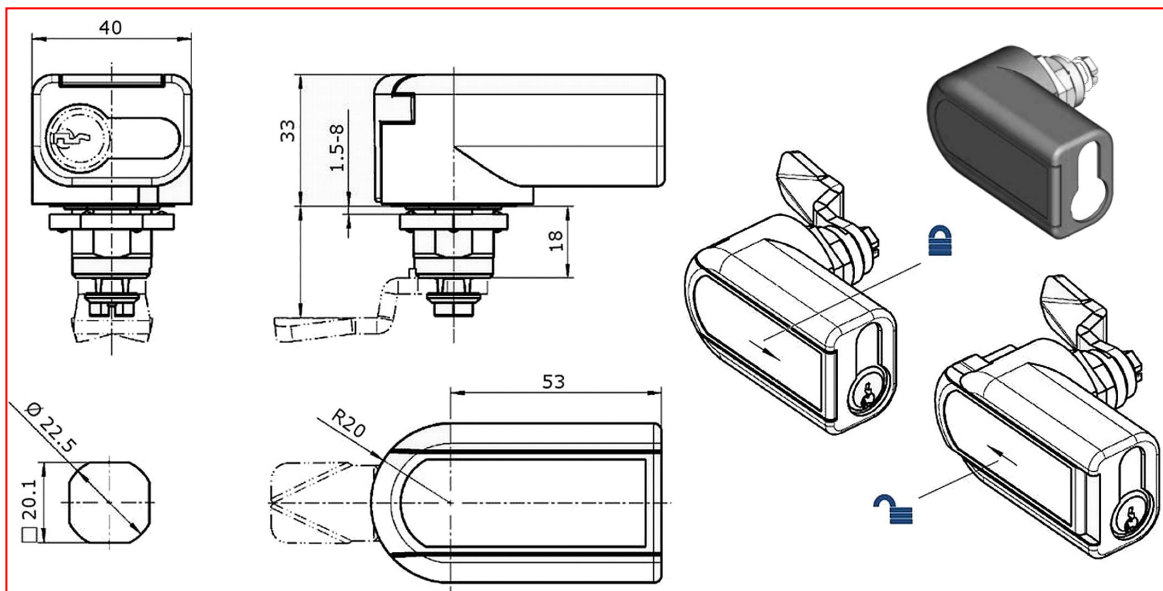

TURNING BOLT FOR HALF CYLINDER

DESCRIPTION	ORDER NO.
Quarter turn for profile half cylinder (substitutes WSSL3532)	IU001925--