

DISPLAY

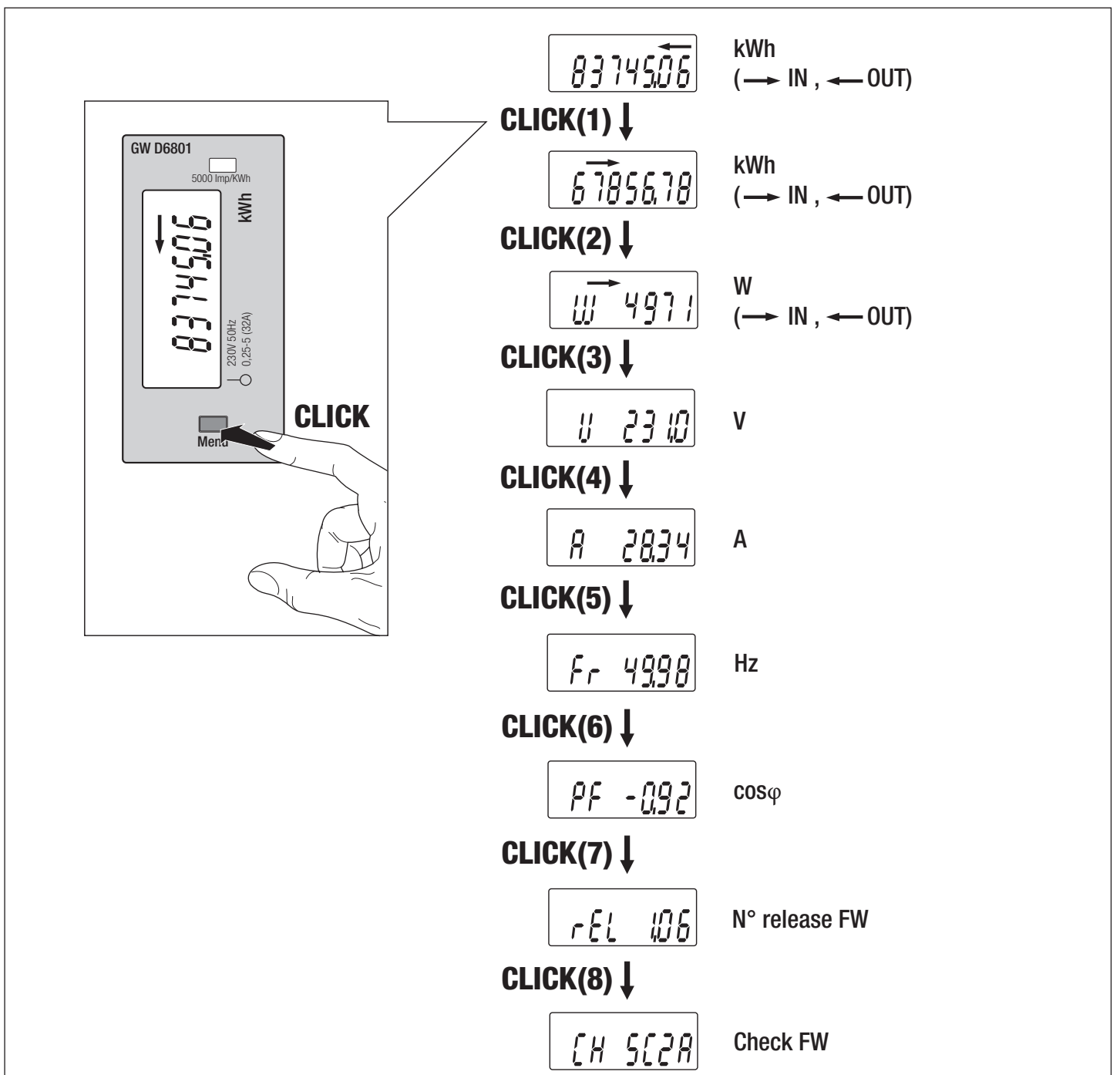

RESET kWh

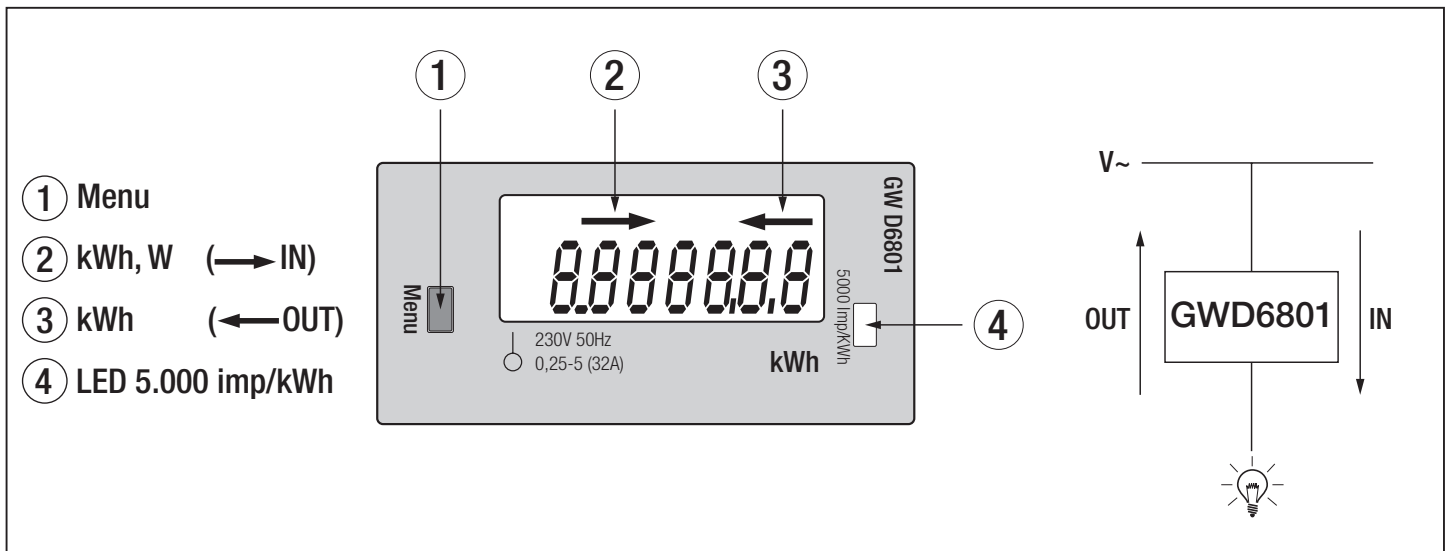

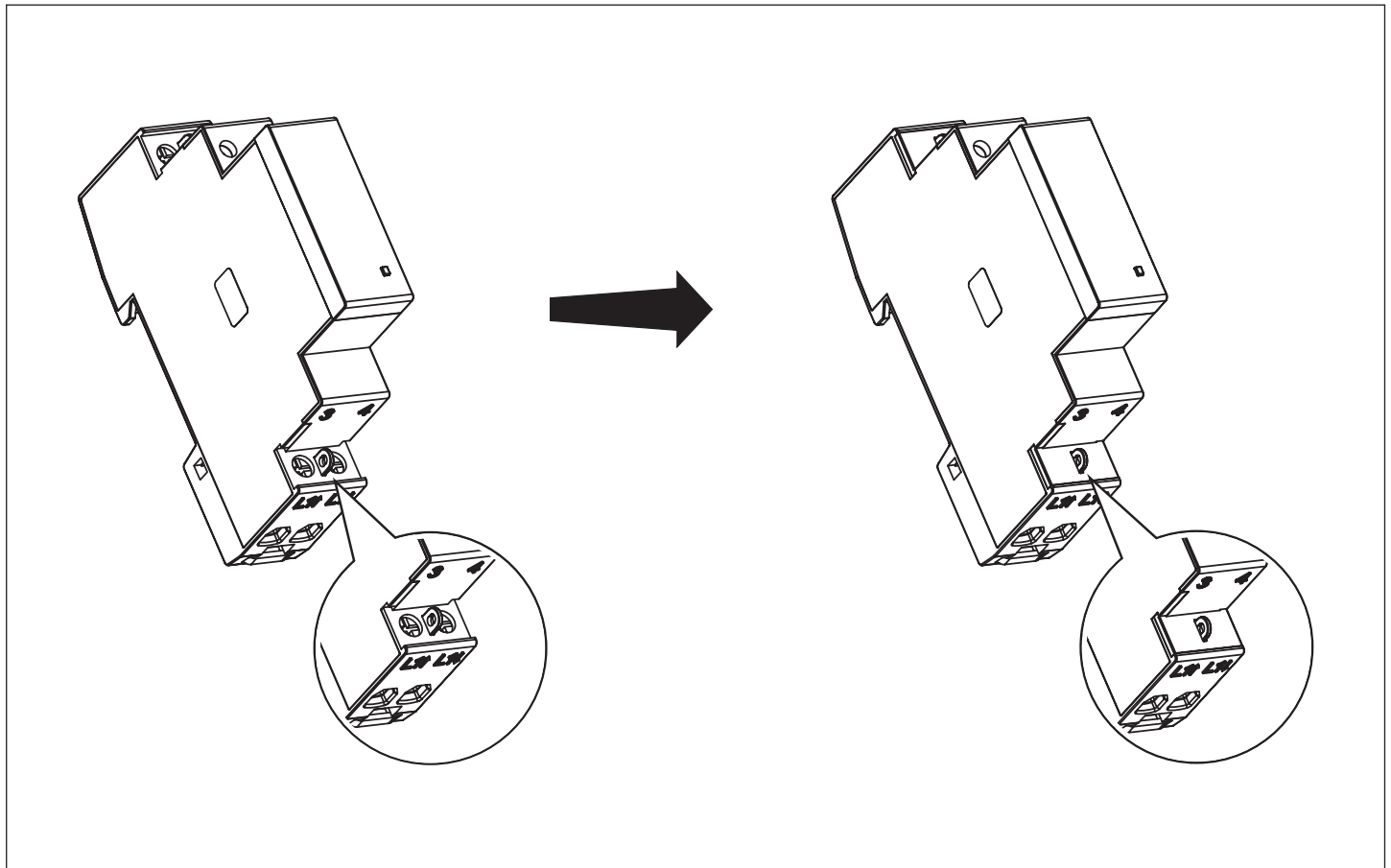
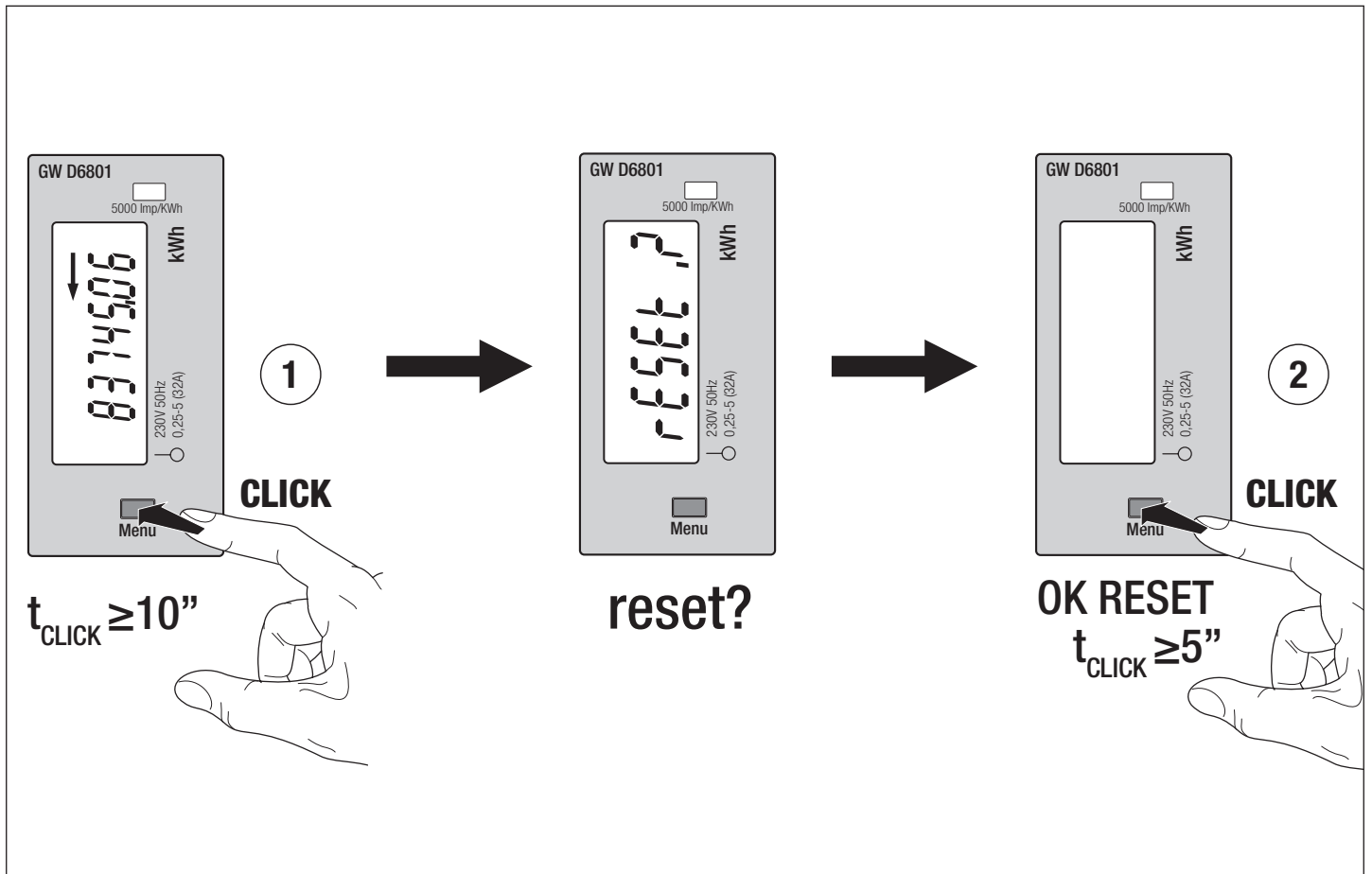

| | |
|--------------------------------|-------------------|
| EN 50470-1 EN 50470-3 | |
| EN 62053-23 EN 62053-31 | |
| Un | 230 VAC |
| I_{max} | 32A |
| I_{ref} | 5A |
| I_{min} | 0,25A |
| I_{st} | 0,02A |
| Fn | 50Hz |
| CI (EN 50470-3) | B |
| CI (EN 62053-23) | 2 |
| Ta | -25°C < T < +55°C |
| 2004/22/CE | M1, E2 |

| | |
|-----------|--|
| RH | Non condensante - تا ع ا ر م د د ع - без кандэнсацыі - некондензираш - bez kondenzace - ikke-konden- serende - ohne Kondensation - Χωρίς συμπύκνωση - not condensing - no condensante - mittekondenseeruv - ei-kondensoiva - sans conden- sation - Nach gcomhdhlúthaíonn - bez kondenzacije - Leccapódás nélkül - конденсацыяланбайды - be kondensacijos - bez kondensācijas - ma jikkonden- sax - niet condenserend - Ikke kondenserende - bez kondensacji - não condensante - non-condensație - Без конденсації вологи - bez kondenzácie - brez kondenzacije - Inte kondenserande - yoğuşmasız - 不凝結 |
|-----------|--|

cod. 7.43.1.779.3

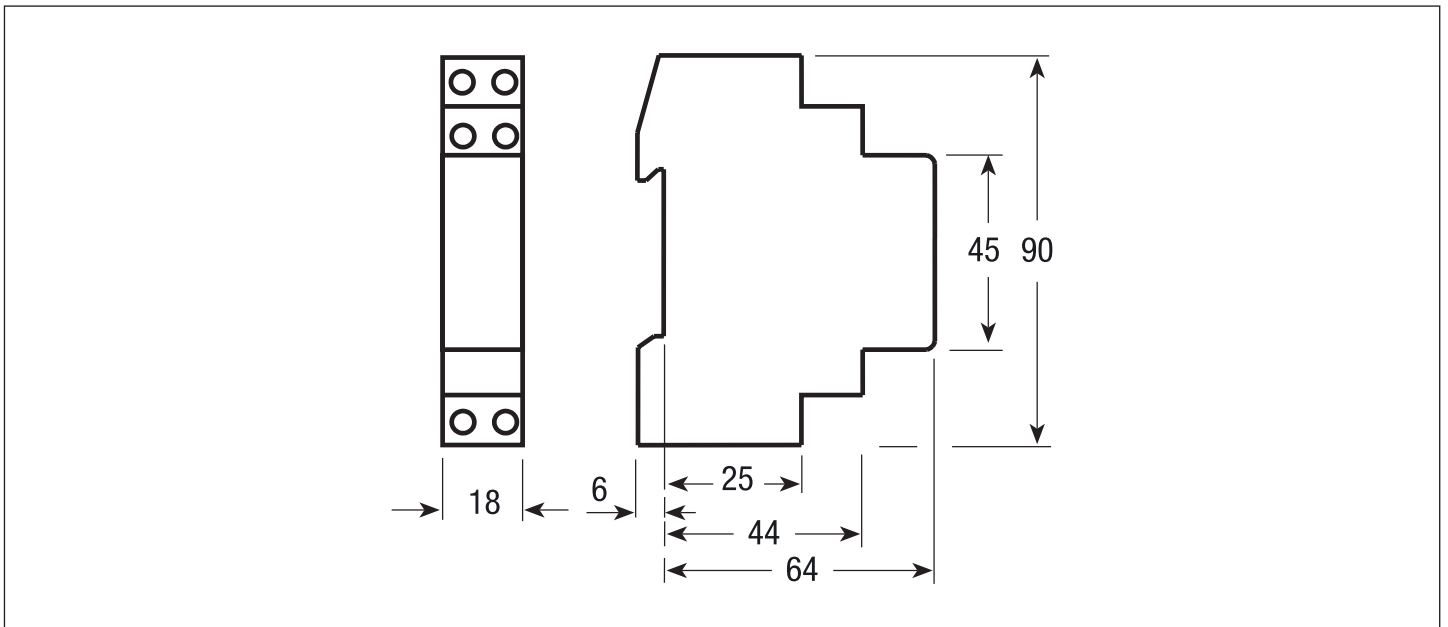

Ai sensi delle Decisioni e delle Direttive Europee applicabili, si informa che il responsabile dell'immissione del prodotto sul mercato Comunitario è:
 According to the applicable Decisions and European Directives, the responsible for placing the apparatus on the Community market is:
GEWISS S.p.A. Via A.Volta, 1 IT-24069 Cenate Sotto (BG) Italy Tel: +39 035 946 111 Fax: +39 035 946 270 E-mail: qualitymarks@gewiss.com



+39 035 946 111
 8.30 - 12.30 / 14.00 - 18.00
 lunedì + venerdì - monday + friday



+39 035 946 260



sat@gewiss.com
www.gewiss.com

ULTIMA REVISIONE 02/2016