

# Scharfer

Professional LED power supplies

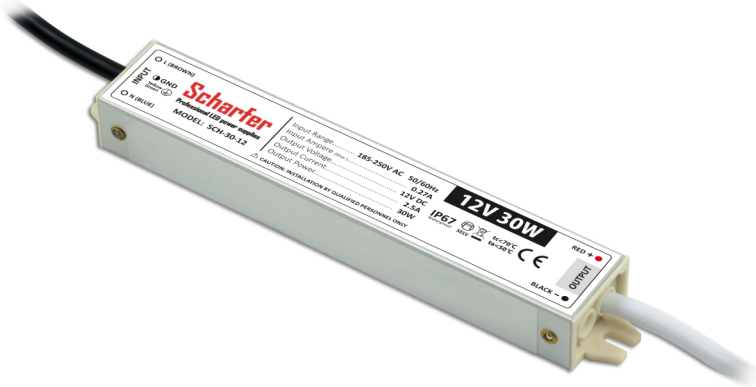

Model: **SCH-30-12**  
**SCH-30-24**

Size: 162\*29\*21mm



## Brief Information

**Powermax™**  
Technology Inside

# 30W

**Waterproof Power Supply (C.V.)**

Model SCH-30-12 / SCH-30-24

Input 170-250V AC

Output 12VDC 2.5A 30W / 24VDC 1.25A 30W

## Product Features

- Compact size, easy for installation
- High transfer efficiency
- Stable constant voltage output
- IP67, both indoor & outdoor use suitable
- 100% full loading, 100% burn-in tested
- Overload/short circuit protection

## MAIN ELECTRICAL DATA

### AC Input

Input Voltage	170-250V
Input Frequency	50/60Hz
Efficiency (Typ.)	85%
Input Current	230V: 0.25A max.
Inrush Current	40A
Leakage Current	1mA/230VAC

### DC Output

Output Voltage	12V	24V
Rated Current	2.5A	1.25A
Rated Power	30W	30W
Ripple & Noise (Max.)	<200mVp-p	<200mVp-p
Setup, Rise Time	1500ms/230VAC	1500ms/230VAC
Line Regulation	1%	1%
Load Regulation	2%	2%

## Service Environment

Working Temp.	-20°C~50°C
Working Humidity	20~99%RH
Storage Temp.	-40°C~80°C
Storage Humidity	10~99%RH

## Protection

Overload	Yes, O/P voltage drop mode, active when overloaded 5-30%, recover after load reduced
Short Circuit	Yes, hiccup mode, recover automatically after fault condition removed

## Safety

Safety Standard	EN 61347-2-13
Withstand Voltage	I/P-O/P: 3000KVAC/1min/<5mA
Isolation Resistance	I/P-O/P: >100M Ohms / 500VDC /25°C / 70%RH

## Packaging Information

Product Dimension	162*29*21mm
Products Net Weight	170G
PCS/Carton(QTY)	100 PCS
Master Carton Size	39*39*21cm
G. Weight/ Carton	19KG

### Installation Tips:

- Please identify the power supply's input and output before installation.
- Ensure correct output + & - wire connection. Power on after wire connection is done.
- To avoid voltage drop and loading capacity wasting on the output extension wire, please install the power supply to the loading as near as possible, if must use long extension wires, thicker wires and less loading wattage is required.
- The power supply to be installed at good ventilation and cooling environment.

# Scharfer

Professional LED power supplies

## Physical Drawing

Unit: mm

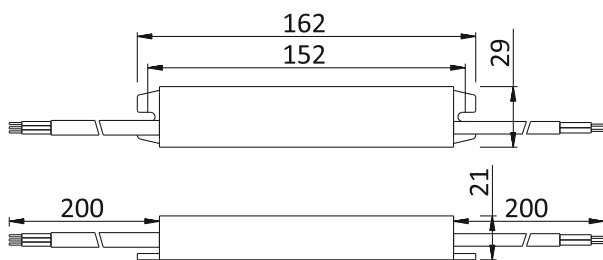

### Brief Information

**Powermax™**  
Technology Inside

## 30W

**Waterproof Power Supply (C.V.)**

Model SCH-30-12 / SCH-30-24

Input 170-250V AC

Output 12VDC 2.5A 30W / 24VDC 1.25A 30W

Input: 3x0.75mm<sup>2</sup> wire, Brown L, Blue N  
200mm length

Output: 2x0.75mm<sup>2</sup> wire, Red +, Black -  
200mm length

Housing: Aluminium

## Block Diagram

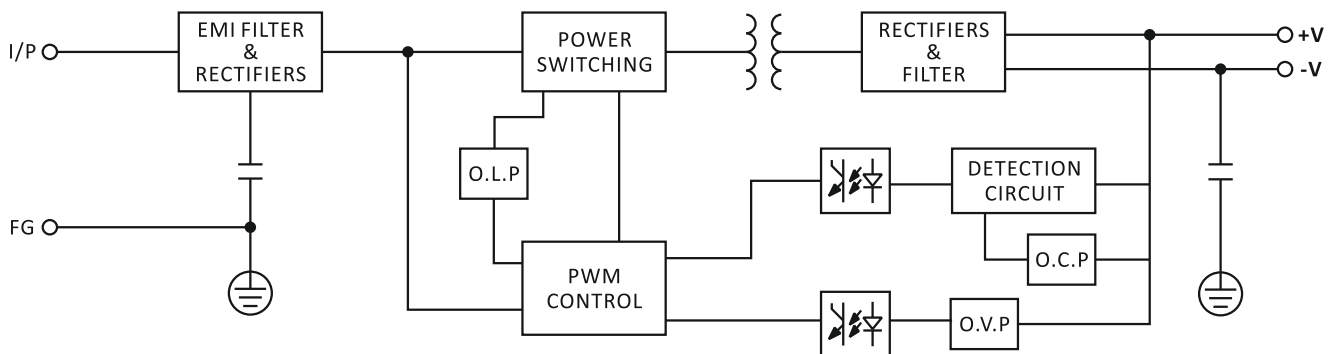

## Derating Curve

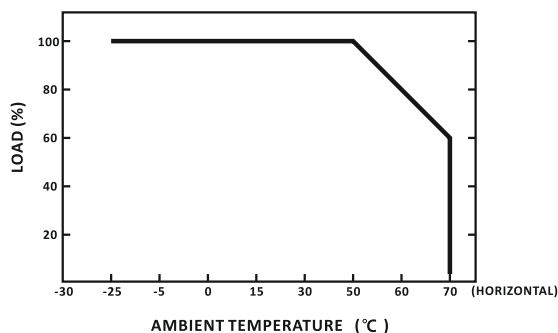

## Static Characteristics

