

Controller - 2 x 0-10 V outputs

Catalogue number(s): 0 488 52

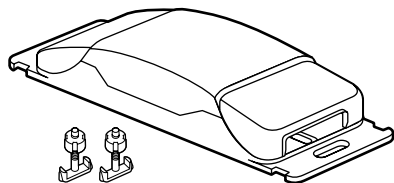

CONTENTS	Page
1. Use	1
2. Technical features	1
3. Overall dimensions	2
4. Connection	2
5. Installation	3
6. Operation	4
7. Parameter setting	5
8. Maintenance	5
9. Standards	5

1. USE

This device is a power unit used for managing 0-10 V lighting loads.

It must be connected to one or more detectors and/or "pushbutton type" diverted auxiliary controls in order to operate.

It has 3 main operating modes:

- "Corridor side/window side": 3 modes → details on page 4
- "Surrounding area": 1 mode → details on page 4
- "Synchronised": 1 mode (used in public buildings) → details on page 4

2. TECHNICAL FEATURES

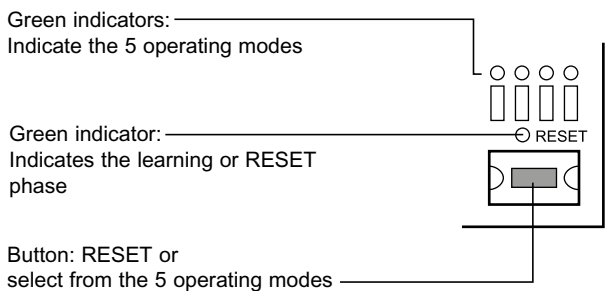

230 V~	1000 VA	4.3 A	1000 VA	4.3 A
110 V~	500 VA		500 VA	

2. TECHNICAL FEATURES (continued)

Voltage: 100-240 V~
Frequency: 50/60 Hz
No load power consumption: 1.5 W

Wiring:

- Power:
 - N ≙ L: 2 x 2.5 mm² (screw terminals)
 - N ≙ ∅: ≤ 1.5 mm² via bistable relay (screw terminals)
 - Control:
 - Pushbuttons: 1 x 1.5 mm² (screw terminals) (100 m max. between the controller and the pushbutton)
 - 0-10 V ballast: ≤ 1.5 mm² (screw terminals) (16 ballasts max. per channel) the distance depends on the type of cable used.
- The product is specifically for 0-10 V, which is selected automatically.

Connection between detector and controller: RJ 45 cord or cable or BUS/SCS cable to be fitted with RJ 45 connector (150 m max. between the controller and the furthest detector)

Product installation: in a suspended ceiling or on a suitable cable tray

BUS detectors:

- Infrared or ultrasound technology or dual technology
- Max. 6 detectors at 110/230 V~
- Pushbutton: - Via normally open contact
- Can be used with an indicator: voltage, 27 V_≅ to display the state of the load in synchronised mode
- Note: It is advisable not to exceed 5 pushbuttons per channel (consumption of indicators)

Usage temperature: -5°C to +45°C
Storage temperature: -20°C to +70°C
Weight: 256 g
Impact resistance: IK04
Penetration by solid and liquid matter: IP20

3. OVERALL DIMENSIONS

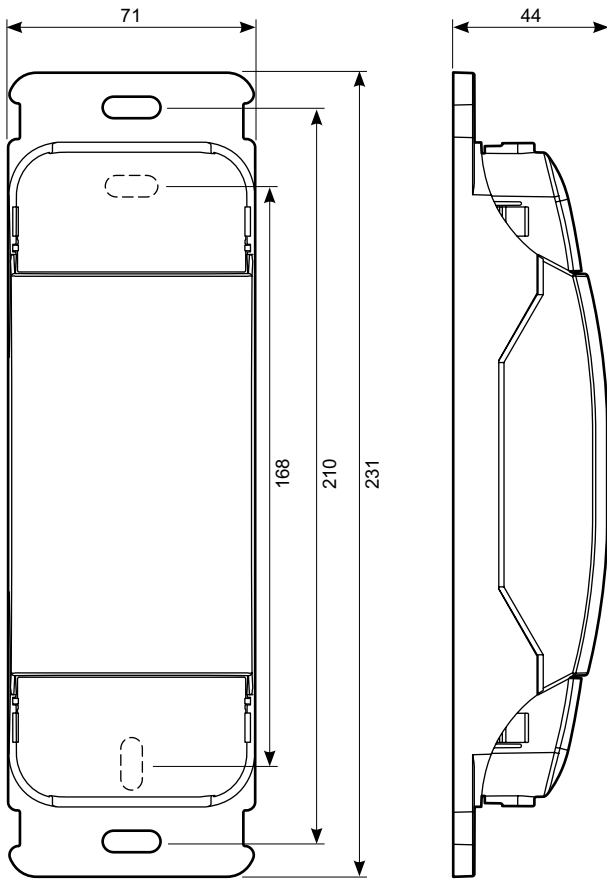

4. CONNECTION

If one of the phases is cut off in an installation with two separate phases, the other phase will continue to supply its associated lighting circuit, in mode 4.

In the event of a connection fault between the detector(s) and controller, the lights will automatically come back on at 100% after 10 minutes.

If the controller fails, the level of the 0-10 V ballasts will be maintained.

The controller has a status memory, which means that when the mains power is restored, it will return to the status it was in before the break for both 0-10 V channels. If the controller has a detector and there is no-one present after the power returns, the system will switch off the lighting at the end of the time delay set on the detector.

4. CONNECTION (continued)

4.1 Wiring 1 (on a single phase)

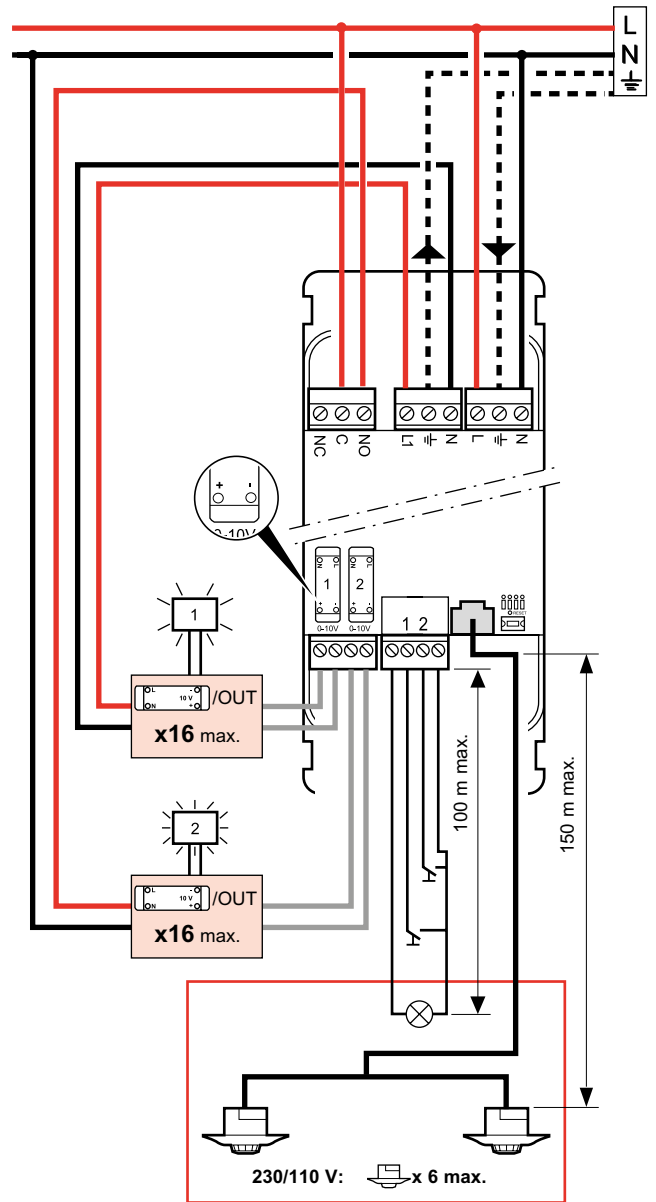

4. CONNECTION (continued)

4.2 Wiring 2 (on 2 phases)

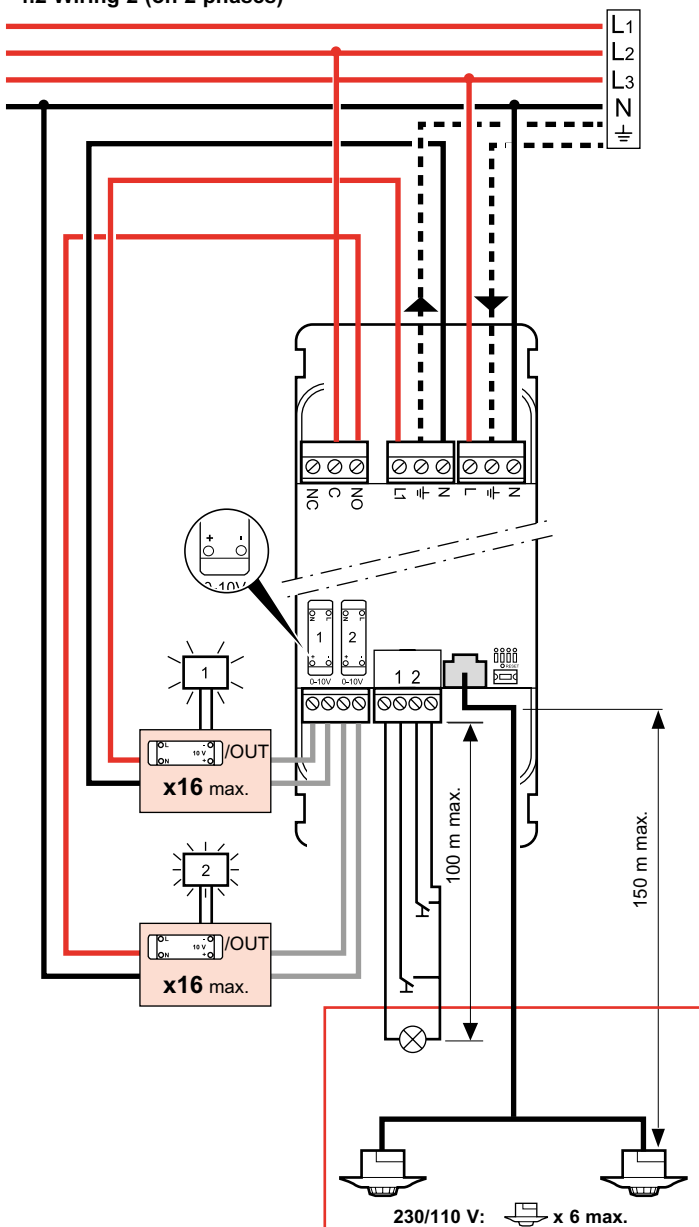

The two channels are synchronised, which enables the luminaires to be placed in staggered rows with one ballast supply phase on each channel.

5. INSTALLATION

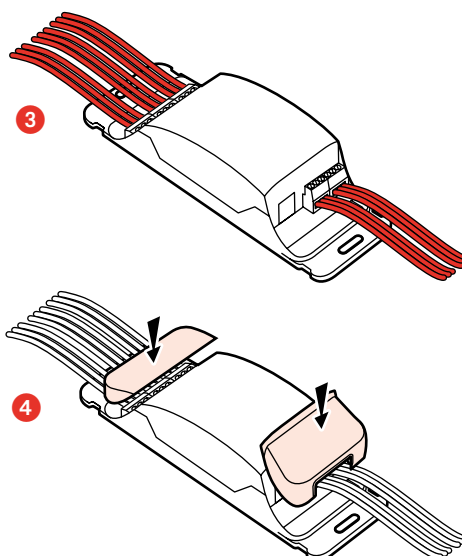
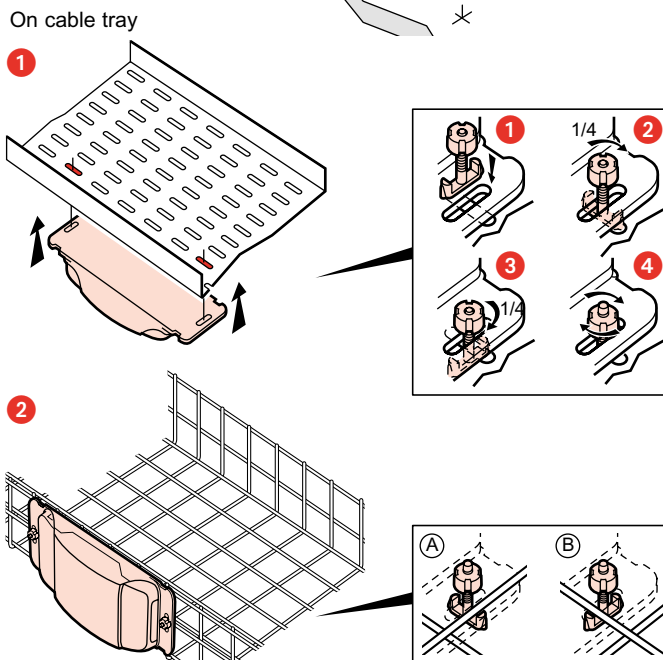
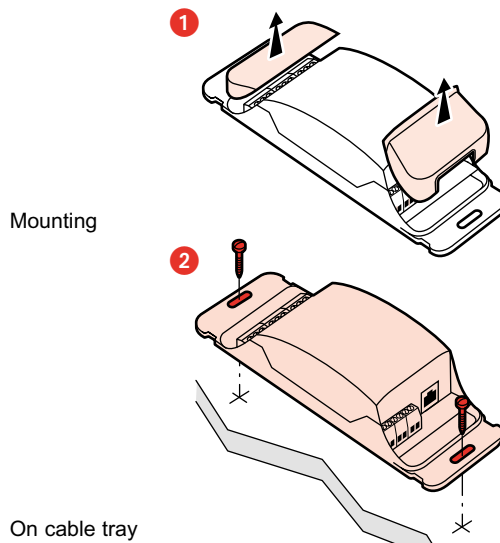

6. OPERATION

6.1 Corridor side - window side operating mode:

Mode 1 - Mode 2 - Mode 3

This operating mode is used to:

- Switch the lighting on and off manually or automatically according to whether or not anyone is present
- Display the status of the lighting from a remote location
- Switch the lighting system off automatically as soon as there is sufficient natural light
- Control lighting points placed less than 5 m away from a window separately from the other lighting points

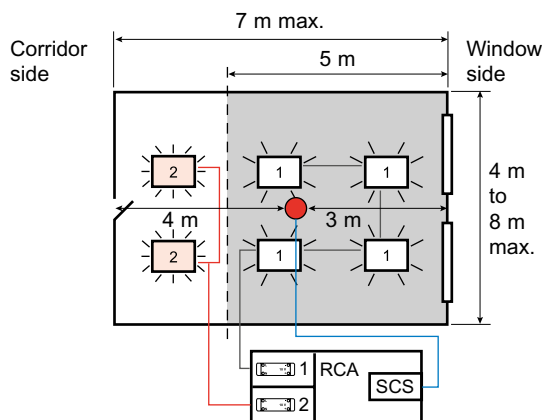

The area can be extended by adding one or more detectors.

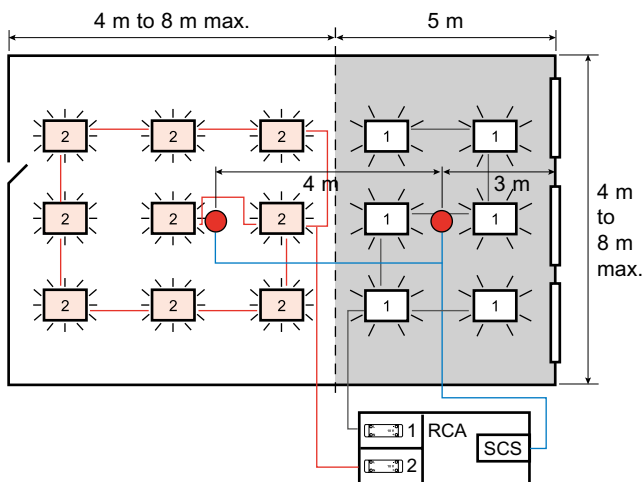

The BUS detector(s) are connected to the controller.

In these modes, the controller applies a dimming difference of +30% (mode 1), +50% (mode 2) and +80% (mode 3) between channel 1 (window side) and channel 2 (corridor side).

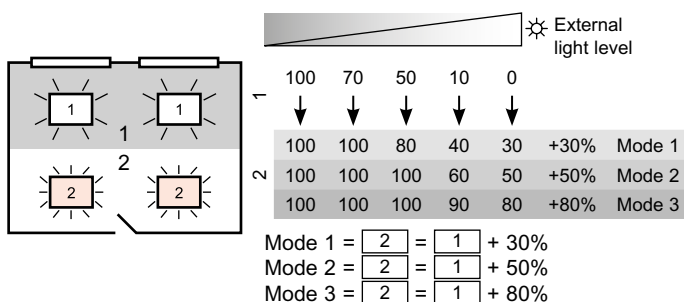

6. OPERATION (continued)

6.2 Surrounding area operating mode: Mode 5

In this mode, the controller applies a 2/3 difference in dimming between the channel controlling the working area (1) and the channel controlling the surrounding area (2).

This mode is optimised for lighting levels of 200 to 750 lux in the working area and complies with the specifications in standard 12464-1.

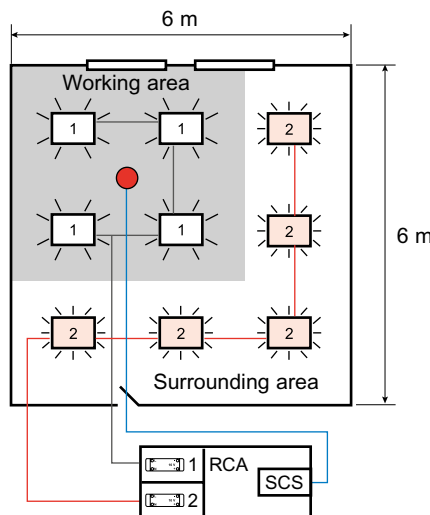

$$\text{Mode 5} = \frac{2}{2} = \frac{2}{3} \frac{1}{1}$$

6.2 Synchronised operating mode: Mode 4

This mode is optimised for public buildings.

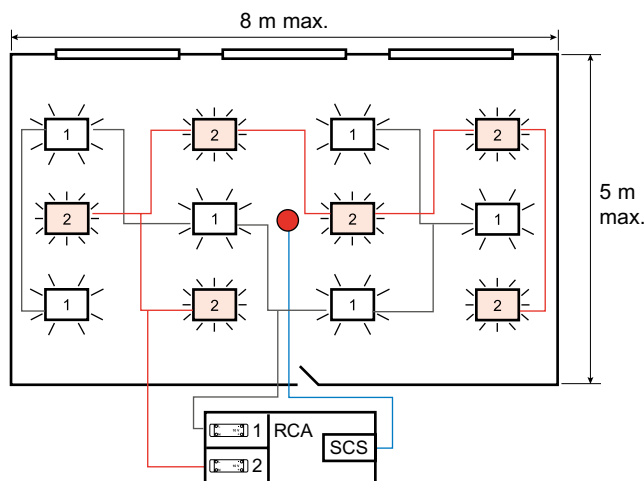

$$\text{Mode 4} = \frac{2}{2} = \frac{1}{1}$$

The 2 channels are synchronised. This enables the luminaires to be placed in staggered rows.

Pushbutton

Both pushbuttons have the same function:

Short press → Both 0-10 V channels are switched on or off

Long press → Increasing or decreasing dimming of both channels. If the load is switched off, the dimming will be increasing after the 1st long press

Note: A short press is less than 400 ms

A long press is more than 400 ms

The pushbuttons can be placed in a room that is not accessible to the public. They can have an indicator (Cat. No. 0 676 67) to indicate the state of the load.

6. OPERATION *(continued)*

Detector

This controls the switching on and off of the two lighting circuits at the end of the time delay.

It regulates the two lighting channels automatically following a sufficient contribution from outside light.

When the contribution from outside light decreases, the two lighting circuits dim proportionally.

6.4 Choice of operating modes

The operating mode of the controller can be changed using the Reset button.

A long press (> 400 ms) on the Reset button is used to scroll through the operating modes. The modes are indicated using 3 LEDs, marked 1 to 3.

When the button has been pressed for 2 s, the LEDs start to flash, indicating that the controller is switching to parameter setting mode. Then a different mode is offered every 4 s. When you reach the mode you want, simply release the Reset button. When the LEDs stop flashing, the new mode has been selected.

LED no.	Operating mode
1 2 3 4	Mode 1 Corridor side = window side + 30%
1 2 3 4	Mode 2 Corridor side = window side + 50%
1 2 3 4	Mode 3 Corridor side = window side + 80%
1 2 3 4	Mode 4 Synchronised
1 2 3 4	Mode 5 Surrounding area

6.5 Override

It is possible to override the electronic control box linking the two channels by using the pushbuttons.

The resulting behaviour is given in the following table.

MODE	Pushbutton 1	Pushbutton 2
Mode 1 = $\square 2 = \square 1 + 30\%$		
Mode 2 = $\square 2 = \square 1 + 50\%$	ON/OFF	ON/OFF
Mode 3 = $\square 2 = \square 1 + 80\%$		
Mode 4 = $\square 2 = \square 1$	ON/OFF	
Mode 5 = $\square 2 = 2/3 \square 1$	ON/OFF	ON/OFF

7. PARAMETER SETTING

When connecting the detector(s) to the controller it must be switched off.

Switching the controller on generates an automatic configuration between the detector(s) and the controller.

The controller carries out a Plug'n Go procedure, analyses the detectors on the BUS SCS then, if necessary, configures them.

It is still possible to reset the assembly, as follows:

- Short press on the Reset button on the controller: the RESET LED flashes slowly
- Long press on the Reset button: the RESET LED starts to flash after 10 seconds. The controller deletes all the detectors connected to it, then reconfigures itself and the detectors
- When the RESET LED goes off, the system is ready to operate

The detectors are configured in walk-through mode, with a 15 minute time delay and a light level of 500 lux.

The parameters of the detector can be set using the configuration tools Cat. No. 0 882 35 (simplified configuration tool) or Cat. No. 0 882 30 (advanced configuration tool).

Consult the relevant technical data sheets for detailed parameter setting of compatible digital detectors.

Note: All technical information is available at



8. MAINTENANCE

Do not use: acetone, tar-removing cleaning agents or trichloroethylene.

Maintenance with the following products: - Hexane (En 60669-1)
- Methylated spirit
- Soapy water
- Diluted ammonia
- Bleach diluted to 10%
- Window-cleaning products

ATTENTION: An initial test is required for the use of other special maintenance products.

9. STANDARDS

Directive: CE

Installation standards: NFC 15-100

Product standards: NF EN 50428

Environmental standards:

- EU Directive 2002/96/EC:
WEEE (Waste Electrical and Electronic Equipment)

- EU Directive 2002/95/EC:
RoHS (Restriction of Hazardous Substances)

- Regulations: ERP (public buildings)
ERT (workplace buildings)
IGH (high-rise buildings)