

# ROOM THERMOSTATS KNX

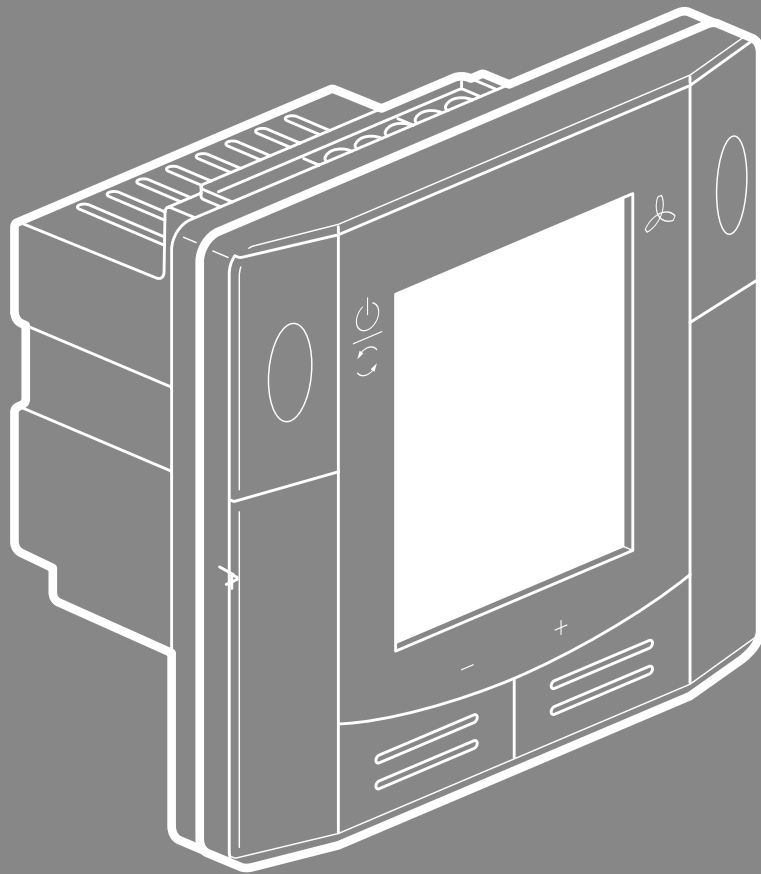

BASIC DOCUMENTATION

---

# Contents

---

2	ABOUT THIS DOCUMENT	59	HANDLING
2	Document use / request to the reader	59	Mounting and installation
2	Target audience, prerequisites	60	Commissioning
2	Glossary	62	Operation
		63	Disposal
3	SUMMARY		
3	Types	64	SUPPORTED KNX TOOLS
3	Functions	64	ETS Professional
4	Integration via KNX bus		
5	FUNCTIONS	65	CONNECTION
5	Temperature control	65	Connection terminals
6	Operating modes	65	Connection diagrams
13	Room temperature setpoints		
17	Applications overview	66	MECHANICAL DESIGN
19	Additional functions	66	General
22	Control sequences	66	Dimensions
35	Control outputs		
36	Fan control	67	TECHNICAL DATA
40	Multifunctional input, digital input	69	INDEX
42	Handling faults		
42	KNX communications		
45	Communication objects (S-mode)		
51	Control parameters		

# About this document

## DOCUMENT USE / REQUEST TO THE READER

Before using our products, it is important that you read the documents supplied with or ordered at the same time as the products (equipment, applications, tools, etc.) carefully and in full.

We assume that persons using our products and documents are authorized and trained appropriately and have the technical knowledge required to use our products as intended.

## TARGET AUDIENCE, PREREQUISITES

This document assumes that users of the thermostats are familiar with the ETS Professional and able to use them.

It also presupposes that these users are aware of the specific conditions associated with KNX.

In most countries, specific KNX know-how is conveyed through training centers certified by the KNX Association.

## GLOSSARY

The inputs, outputs and parameters of an application can be influenced in various ways. These are identified by the following symbols in this document:

 Parameters identified by this symbol are set using ETS Professional.

### NOTE!

Setting KNX parameters is only supported by the following tool versions:  
- ETS3f or higher

 Inputs and outputs identified by this symbol communicate with other KNX devices.

They are called communication objects (CO).

The communication objects of the thermostats work in S-mode. These objects are described accordingly.

A list of the parameters is shown in page 51.

# Summary

## TYPES

Operating voltage	Control outputs				Housing color
	3-pos	ON/OFF	DC 0..10 V	KNX switching groups	
AC 230 V	1 <sup>(1)</sup>	2 <sup>(1)</sup>			White

<sup>(1)</sup> Selectable: ON/OFF or 3-position

## FUNCTIONS

### Use

**Fan coil units** via ON/OFF or modulating control outputs:

- 2-pipe system
- 2-pipe system with electric heater
- 4-pipe system

**Chilled / heated ceilings (or radiators)** via ON/OFF or modulating control outputs:

- Chilled / heated ceiling
- Chilled / heated ceiling with electric heater
- Chilled / heated ceiling and radiator / floor heating

**Compressors:** Via ON/OFF control

- 1-stage compressors in DX type equipment
- 1-stage compressors in DX type equipment with electric heater

The room thermostats are delivered with a fixed set of applications.

The relevant application is selected and activated during commissioning using one of the following tools:

- ETS Professional
- Local DIP switch and HMI

### Features

- Operating modes: Comfort, Economy (Energy Saving) and Protection
- ON/OFF or 3-position control outputs (relay)
- Output for 3-speed or 1-speed fan
- Automatic or manual heating / cooling changeover
- Backlit display
- C 230 V operating voltage

### Functions

- Room temperature control via built-in temperature sensor or external room temperature / return air temperature sensor
- Changeover between heating and cooling mode (automatic via local sensor or bus, or manually)
- Selection of applications via DIP switches
- Select operating mode via operating mode button on the thermostat
- Temporary Comfort mode extension
- 1- or 3-speed fan control (automatically or manually)

## Summary (continued)

- Display of current room temperature or setpoint in °C and/or °F
- Minimum and maximum limitation of room temperature setpoint
- Button lock (automatically or manually)
- 2 multifunctional inputs, freely selectable for:
  - Operating mode switchover contact (keycard, window contact, etc.)
  - Sensor for automatic heating / cooling changeover
  - External room temperature or return air temperature sensor
  - Dew point sensor
  - Electric heater enable
  - Fault input
  - Monitor input for temperature sensor or switch state
- Advanced fan control function, e.g. fan kick, fan start, selectable fan operation (enable, disable or depending on heating or cooling mode)
- "Purge" function together with 2-port valve in a 2-pipe changeover system
- Reminder to clean fan filters
- Floor heating temperature limitation
- Reload factory settings for commissioning and control parameters

### INTEGRATION VIA KNX BUS

- Integration into third-party systems via group addressing (ETS).

The following KNX functions are available:

- Central time program and setpoints
- Outside temperature or time of day via bus displayed on thermostat
- Remote operation and monitoring,
- Maximum energy efficiency due to exchange of relevant energy information,)
- Alarming, e.g. external fault contact, condensation, clean filter, etc.
- Monitoring input for temperature sensor or switch

Engineering and commissioning can be done using...

- local DIP switches / HMI
- ETS Professional

## Functions

### TEMPERATURE CONTROL

**General note:**

**Parameters**

Setting of the control parameters (P01, etc., mentioned throughout the document) is described in page 51.

**Temperature control**

The thermostat acquires the room temperature via built-in sensor, external room temperature sensor, or external return air temperature sensor, and maintains the setpoint by delivering actuator control commands to heating and/or cooling equipment. The following control outputs are available:

- ON/OFF control (2-position)
- Modulating PI/P control with 3-position control output (only for 2-pipe applications)

The switching differential or proportional band is 2 K for heating mode and 1 K for cooling mode (adjustable via parameters P30 and P31).

The integral action time for modulating PI control is 5 minutes (adjustable via parameter P35).

**Display**



The display shows the acquired room temperature or the Comfort setpoint, selectable via parameter P06. The factory setting displays the current room temperature.

Use parameter P04 to display the room temperature or setpoint in °F rather than °C as needed.

**Room temperature**

**KNX** The acquired room temperature (internal or external sensor) is also available as information on the bus.

• With automatic changeover or continuous heating / cooling, symbols  indicate that the system currently heats or cools (heating or cooling output is activated).

• With manual changeover (P01 = 2), symbols  indicate that the system currently operates in heating or cooling mode. Thus, the symbols are displayed even when the thermostat operates in the neutral zone. Symbols  indicate that the system currently heats or cools (heating or cooling output is activated).

**Concurrent display of °C and °F**

Concurrent display of the current temperature or setpoint in °C and °F (parameter P07 = 1) is possible on the thermostats.

**Outside temperature via bus**

**KNX** The outside temperature can be displayed on the room thermostat by setting parameter P07 = 2. This temperature value has only information character.

In S-mode, the corresponding communication object needs to be bound with a KNX sensor device.

## Functions (continued)

### Time of day via bus

Time of day via bus can be displayed on the room thermostat by setting parameter P07 = 3 or 4. The display format is either in 12- or in 24-hour format. The information can be received from a KNX device if the corresponding communication object is bound.

### OPERATING MODES

The thermostat's operating mode can be influenced in different ways (see below). Specific heating and cooling setpoints are assigned to each operating mode.

### Room operating mode: State

The thermostat sends the effective room operating mode on the bus.

The following operating modes are available:

#### Auto Timer

In Auto Timer mode the room operating mode is commanded via bus. Auto Timer is replaced by Comfort when no time schedule via bus is present.

#### Comfort

In Comfort mode, the thermostat maintains the Comfort setpoint. This setpoint can be defined via parameters P8, P9 and P10.

It can be locally adjusted via the +/- buttons or via bus.

In Comfort mode, the fan can be set to automatic or manual fan speed: Low, medium or high.

### Economy

The setpoints (less heating and cooling than in Comfort mode) can be defined via parameters P11 and P12.

The thermostat switches to Economy mode when...

- the operating mode button is pressed (only possible if parameter P02 is set to 2)
- Economy is sent via bus

### Room operating mode: Window state

- an operating mode switchover contact (e.g. keycard contact presence detector, window contact) is active.

The contact can be connected to multifunctional input X1, X2. Set parameter P38 / P40 to 3 (P02 is irrelevant)\*

- "Window state" is sent via bus, e.g. from a KNX switch or a KNX presence detector (P02 is irrelevant)\*

#### NOTE:

(\*) Operating mode switchover: Only one input source must be used, either local input X1/X2 or KNX bus.

User operations are ineffective and "OFF" is displayed if the operating mode switchover contact is active, or if "Window state" is sent via bus.

## Functions (continued)

### Protection

In Protection mode, the system is...

- protected against frost (factory setting 8 °C, can be disabled or changed via P65)
- protected against overheating (factory setting OFF, can be enabled or changed via P66)

No other operating mode can be selected locally if Protection mode is commanded via bus and are displayed.

### DIFFERENT WAYS TO INFLUENCE THE OPERATING MODE

#### Source for change of operating mode

The operating mode can be influenced by different interventions.

Source	Description	Value of DP "Cause"
Local operation via operating mode button	- Operating mode is not Auto Timer	Room operating mode selector (preselection)
	- No time schedule via bus	"Timer" function
	- Temporary Comfort extension is active	Room operating mode contact
Bus command	- Operating mode switchover contact	Room operating mode contact
	"Window state" sent via bus	Room operating mode contact
Room op. mode	- Time schedule available via bus → local operating mode is set to Auto Timer  - Time schedule sends Protection mode via bus → operating mode cannot be changed locally	Time switch

## Functions (continued)

### Priority of operating mode interventions



The following table shows the priorities of different interventions. A lower number means a higher priority.

Priority	Description	Remark
①	Commissioning	In parameter setting mode (highest priority), you can always command an operating mode independent of all other settings or intervention via bus and local input.
②	Protection mode via bus from time schedule	Protection mode, sent by a time schedule, has priority 2. It cannot be overridden by the user nor by an operating mode switchover contact.
③	Operating mode switchover contact	If the contact is closed, the operating mode changes to Economy. This overrides the operating mode on the thermostat.
③	"Window state" via bus	"Window state" sent via bus has the same effect as the operating mode switchover contact.  <b>NOTE:</b> Only one input source must be used, either local input X1/X2 or KNX bus.
④	Operating mode button	The user can switch the operating mode using the operating mode button.
④	Operating mode via bus	The operating mode can be changed via bus
④	Temporary extended Comfort mode via operating mode button	The operating mode can be temporarily set from Economy to Comfort by pressing the operating mode button, if... - Economy was sent via bus - extended Comfort period >0 (parameter P68)  The last intervention wins, either locally or via bus
④	Time schedule via bus	The operating mode sent via bus can be overridden by all other interventions. Exception: Protection mode has priority 2.

## Functions (continued)

### Auto Timer mode with time schedule via bus

If a time schedule via bus is present, e.g. from central control unit, then the Auto Timer mode  is active. The thermostat automatically changes between Comfort and Economy according to the time schedule via bus.











The display shows the Auto Timer mode symbol  along with the symbol for the effective room operating mode (Comfort  or Economy ).

By pressing the operating mode button, you can change to another operating mode.

Automatic fan is the default fan speed in Auto Timer mode.

### Behavior when bus sends new operating mode

Each time the time schedule sends a new operating mode (switching event), the operating mode of the thermostat is set back to Auto Timer mode. This is to assure that the room temperature is maintained according to the time schedule.

P02	Without time schedule	With time schedule via bus	Description
1	 → 	 → 	- Switching manually between 2 modes, Economy is not available (factory setting) - Suited for hotel guest rooms or commercial buildings. - If a time schedule via bus is available, then the Comfort mode can be temporarily extended (see below)
2	 →  → 	 →  →  → 	- Switching manually between 3 modes - Suited for homes and rooms where manual switching to Economy mode is desired

### Precomfort via bus

If the time schedule sends Precomfort mode, then this mode will be transformed either into Economy (factory setting) or Comfort (selectable via parameter P88).

### Behavior when bus sends Protection

No intervention is possible neither by the user nor by an operating mode switch-over contact, if Protection mode is set by the time schedule. OFF flashes on the display when the user presses a button.

### Availability of Economy mode

The operating mode can be selected locally via the operating mode button. The behavior of the operating mode button (user profile) can be defined via parameter P02, factory setting is P02 = 1.

## Functions (continued)

### Operating mode switchover contact (window contact)

The thermostat can be forced into Economy mode (e.g. when a window is opened, when a presence detector signals "no one present", when the keycard of a hotel room is withdrawn, etc). The contact can be connected to multifunctional input X1, X2. Set parameter P38, P40 to 3.

### KNX Room operating mode: Window state

The function is also available via the KNX signal "Window state", e.g. from a KNX switch or a KNX presence detector.

Note: Only one input source must be used, either local input X1/X2 or KNX bus.

User operations are ineffective and "OFF" is displayed if the operating mode switchover contact is active, or if "Window state" is sent via bus.

### Temporary timer to extend the Comfort mode

Comfort mode can be temporarily extended (e.g. working after business hour or on weekends) when the thermostat is in Economy mode. The operating mode button switches the operating mode back to Comfort for the period preset in P68.

Press the operating mode button again to stop the timer.

The following conditions must be fulfilled:

- mode selection via operating mode button is set to "Protection-Auto" (P02 = 1) and the time schedule via bus is Economy.
- Parameter P68 (extend Comfort period) is greater than 0.

During the temporary Comfort mode extension, symbol appears.

If parameter P68 (extend Comfort period) = 0, extended Comfort cannot be activated; pressing the operating mode button will switch the thermostat to Protection.

If the operating mode switchover contact is active, pressing the operating mode button will show "OFF" (blinking).

## Functions (continued)

### COMMUNICATION EXAMPLES

The following examples show two typical applications of a central time schedule in conjunction with local control of the room operating mode.

The room operating mode in rooms 1...2 of a building is determined by the time schedule. Window contacts are fitted in all rooms.

The following conditions are specified:

The rooms are used and controlled by the time schedule as follows:

- Night setback from 17:00 to 08:00 (Economy)
- Protection from 20:00 to 06:00
- Lunch break from 12:00 to 13:00 (Precomfort)

The substitution (parameter P88) for Precomfort via bus is set on the thermostats as follows:

- Room 1: Comfort (1)
- Room 2: Economy (0)

### Example 1 : Operating mode switchover

In **room 1**, the window is opened briefly, once in the morning, once in late afternoon and once at night <sup>(1)</sup>. Only the opening in the morning has a direct impact on the effective room operating mode.

During lunch break, the time schedule changes to Precomfort. The mode remains in Comfort as set by parameter "Transformation Precomfort" (P88 = 1).

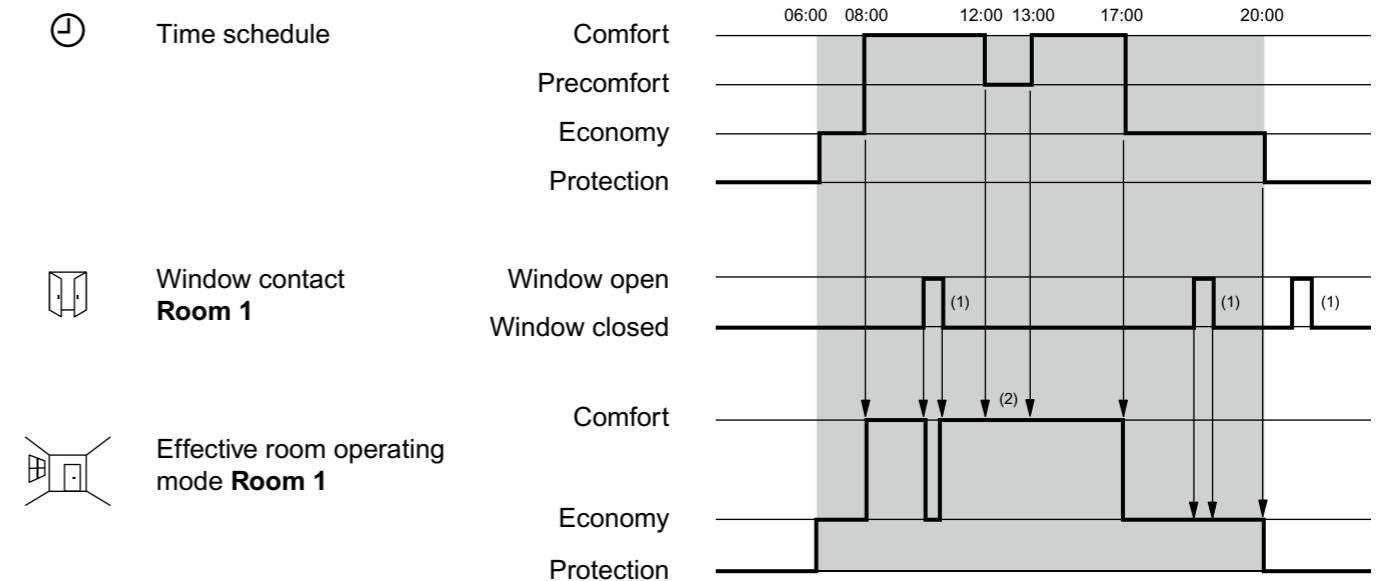

## Functions (continued)

### Example 2 : Interaction of user operation (operating mode button) and central time schedule

In **room 2**, the window is opened briefly, once in the morning and once at night (1). Only the opening in the morning has a direct impact on the effective room operating mode.

With the operating mode button, the operating mode can be changed between OFF and Auto or temporary Comfort extension respectively.

- During lunch break, the time schedule changes to Precomfort. The mode of the thermostat changes to Economy as set by parameter "Transformation Precomfort" (P88 = 0) <sup>(6)</sup>

- During lunch break, the user changes the operating mode to Comfort (temporary Comfort extension) by pressing the operating mode button <sup>(2)</sup>. At 13:00, the timer is reset due to mode change of the central time schedule
- In the afternoon, the user switches the thermostat off by pressing the operating mode button <sup>(3)</sup>. At 17:00 the user setting is reset to Economy by the time schedule
- At 19:30, the user again extends the Comfort mode <sup>(4)</sup>. At 20:00, the timer is reset by the time schedule
- After 20:00, pressing the operating mode button has no effect, as the central time switch sets the thermostat to Protection <sup>(5)</sup>.

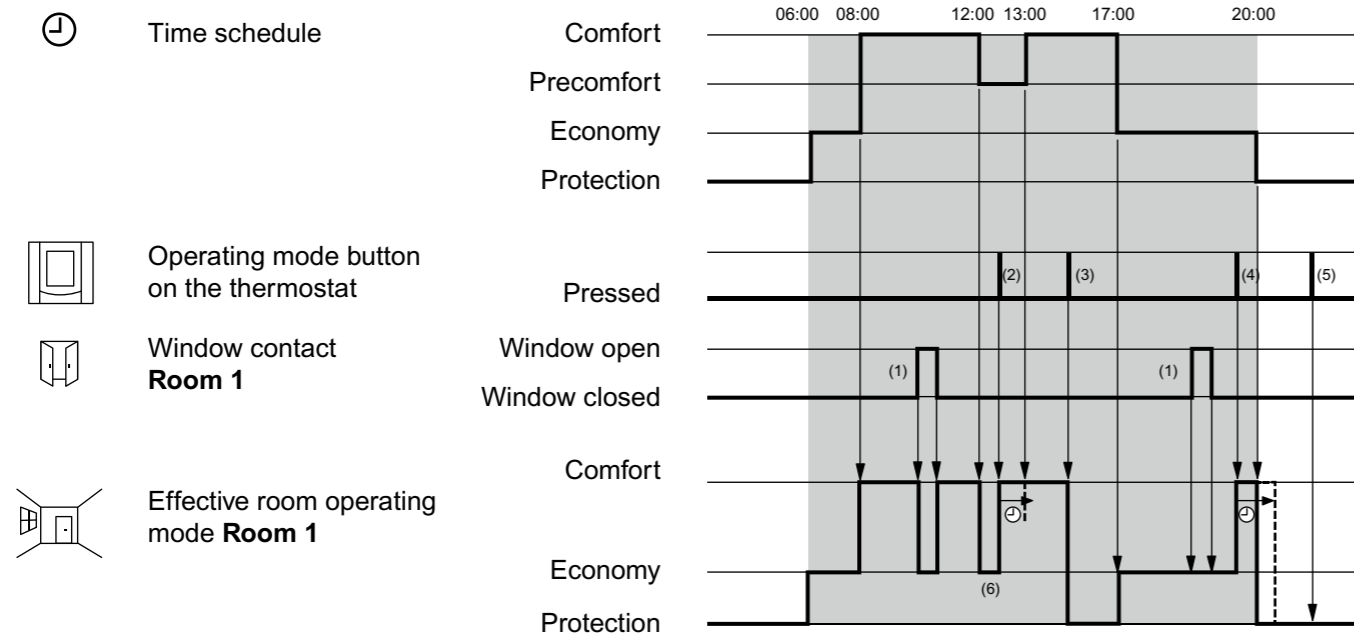

## Functions (continued)

### ROOM TEMPERATURE SETPOINTS

#### DESCRIPTION

#### ☀ Comfort mode

The factory setting for the Comfort basic setpoint is **21 °C** and can be changed in the thermostat's EEPROM via parameter P08 or via bus with communication object "Comfort basic setpoint". The last intervention always wins.

The Comfort setpoint can be adjusted via the +/- buttons, or via bus from a remote device like a touchpanel, operating unit, etc. The last intervention always wins.

#### Temporary setpoint

If the "Temporary setpoint" function is enabled via parameter P69, the Comfort setpoint adjusted via the +/- buttons or via bus is set back to the Comfort basic setpoint stored in P08 when the operating mode changes.

#### Setpoint limitation

For energy saving purposes, the setpoint setting range can be limited to minimum (P09) and maximum (P10).

#### P09 < P10

- If the minimum limit P09 is set lower than the maximum limit P10, both heating and cooling are adjustable between these 2 limits
- The customer adjusts the desired setpoint and the thermostat controls the room temperature accordingly.
- For 4-pipe applications, the selected comfort setpoint is in the middle of the dead zone (P33). The unit stops to energize the heating / cooling outputs as soon as the room temperature reaches the dead zone.

#### Example

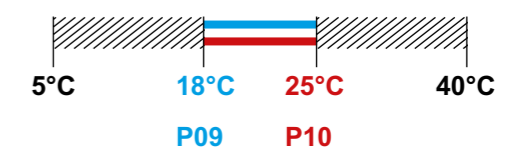

Cooling setpoint adjustable 18...25 °C  
Heating setpoint adjustable 18...25 °C



# Functions (continued)

## P09 ≥ P10

- If the minimum limit P09 is set higher than the limit P10, then
  - The setting range of cooling setpoint is from P09...40 °C in place of 5...40 °C
  - The setting range of heating setpoint is from 5... P10 °C in place of 5...40 °C.

This allows the user to limit the maximum heating setpoint and the minimum cooling setpoint. This concept helps to save energy costs.

- For 4-pipe applications
  - The thermostat runs with the setpoint of the active sequence:
    - In heating mode, the heating setpoint is active and adjustable via "+" / "-" buttons. In cooling mode, the cooling setpoint is active and adjustable via "+" / "-" buttons.
  - Switching from the heating setpoint to the cooling setpoint and vice-versa occurs when the room temperature reaches the adjusted limitation (P09 or P10) of the inactive sequence. E.g. the thermostat is in heating sequence and runs with the heating setpoint. When the room temperature reaches P09, the thermostat switches to cooling mode and runs with the cooling setpoint, as long as the room temperature does not drop below P10.

### Example

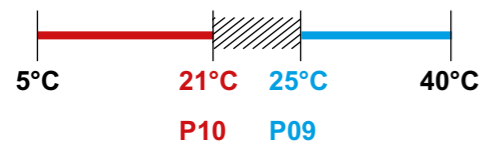

Cooling setpoint adjustable 25...40 °C  
 Heating setpoint adjustable 5...21 °C

## Economy mode

Use control parameters P11 and P12 to adjust the Economy mode setpoints.  
 The heating setpoint is factory-set to 15 °C, and the cooling setpoint to 30 °C.

## Protection mode

Use control parameters P65 and P66 to adjust the Protection mode setpoints.  
 The heating setpoint is factory-set to 8 °C (frost protection) and to OFF for cooling.

### CAUTION:

If a setpoint (Economy or Protection) is set to OFF, the thermostat does not control the room temperature in the corresponding mode (heating or cooling). This means no protective heating or cooling function and thus risk of frost in heating mode or risk of overtemperature in cooling mode!  
 The Economy setpoints are accessible at the service level (P11, P12); the Protection setpoints at the expert level (P65, P66).

# Functions (continued)

## SETTING AND ADJUSTING SETPOINTS

Room temperature setpoints can be:
 

- set during commissioning
- adjusted during runtime

### KNX Comfort basic setpoint Comfort setpoint

The source can be:
 

- the local HMI
- a tool
- a central control unit

The thermostat stores the setpoints
 

- in EEPROM in the form of parameters
- in the runtime memory

The table below shows the interrelations:

Setpoint setting	
<b>Commissioning</b>	<b>Input S-mode</b>
- HMI	
- Tool download	
Comfort basic setpoint	Comfort basic setpoint
Dead zone Comfort <sup>(1)</sup>	
Setpoint Economy Heating	
Setpoint Economy Cooling	
Setpoint Protection Heating	
Setpoint Protection Cooling	
Stored in EEPROM of thermostat	
P08 Comfort basic setpoint	
P33 Dead zone Comfort <sup>(1)</sup>	
P11 Economy Heating	
P12 Economy Cooling	
P65 Protection Heating	
P66 Protection Cooling	

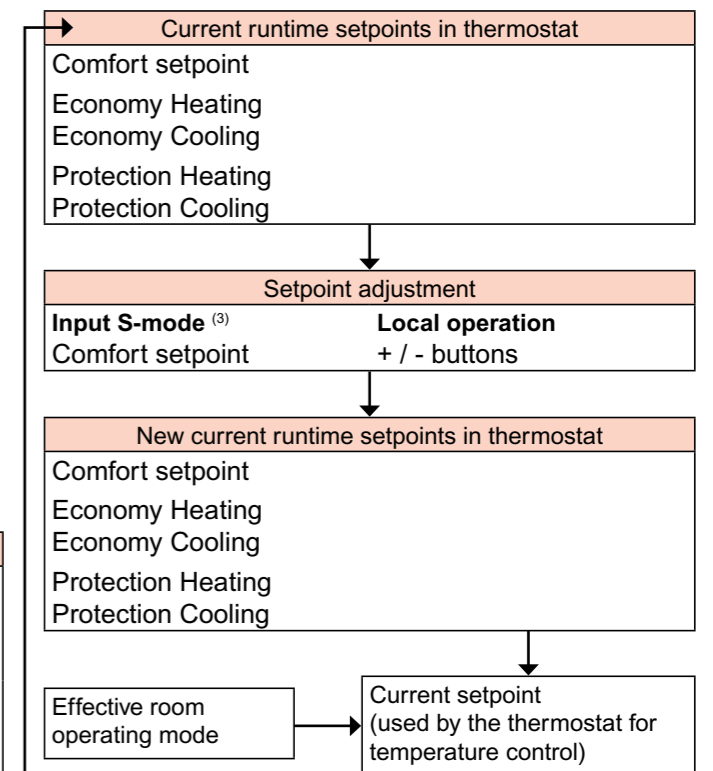

<sup>(1)</sup> Only required for heating AND cooling applications (see page 33)

<sup>(3)</sup> S-Mode: **the last intervention wins**, either S-Mode input or local operation

## Functions (continued)

### KNX Current setpoint

The current setpoint (used by the thermostat for temperature control) is available on the bus for use in the central control unit.

#### Clarification concerning current setpoint in Comfort mode

The comfort setpoint  $w$  (e.g. customer setting on the display) and the current setpoint  $w2$  (used by the thermostat for temperature control, but not visible on the unit) is handled differently depending of the selected application and setting:

- **2-pipe or 4-pipe with P09>P10**

The comfort setpoint  $w$  and current setpoint  $w2$  have the same value.

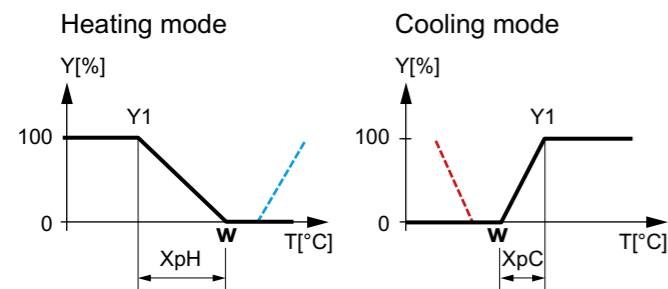

- **4-pipewith P09<P10**

The comfort setpoint  $w$  (value selectable via e.g. +/- buttons) is in the middle of the dead zone (P33). The current setpoints  $w2..$  (used by the thermostat for temperature control) are at the boundaries of the dead zone.

$w2h = \text{Comfort setpoint } (w) - \frac{1}{2} \text{ dead zone } (Xdz)$

$w2c = \text{Comfort setpoint } (w) + \frac{1}{2} \text{ dead zone } (Xdz)$

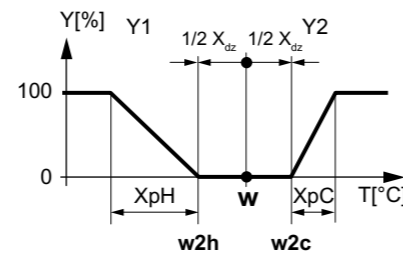

#### General notes:

- Changes via the local HMI or via tool have the same priority (last always wins).
- Setting the Comfort basic setpoint will reset the runtime Comfort setpoint to the basic setpoint.

## Functions (continued)

### APPLICATIONS OVERVIEW

The thermostats support the following applications, which can be configured using the DIP switches inside the front panel of the unit or a commissioning tool.

All DIP switches need to be set to OFF (remote configuration, factory setting) to select an application via commissioning tool.

The tool offers the applications printed in bold text (basic applications).

For universal applications (chilled ceiling, etc.), refer to page 32.

For compressor applications, refer to page 32.

Application and output signal	DIP switches	Diagram
<b>Remote configuration</b> via commissioning tool (factory setting) • ETS Professional		
<b>Heating or cooling</b> • <b>2-pipe fan coil unit</b> (heating or cooling) • Chilled / heated ceiling (heating or cooling) • 1-stage compressor (heating or cooling)	ON/OFF ON/OFF ON/OFF 	
• 2-pipe fan coil unit (heating or cooling) • Chilled / heated ceiling (heating or cooling)	3-position 3-position 	

## Functions (continued)

Application and output signal	DIP switches	Diagram
<b>Heating or cooling with electric heater</b> • 2-pipe fan coil unit with electric heater (heating or cooling) • Chilled / heated ceiling with electric heater, (heating or cooling) • 1-stage compressor with electric heater, (heating or cooling)	ON/OFF ON/OFF ON/OFF	
<b>Heating and cooling</b> • 4-pipe fan coil unit (heating and cooling) • Chilled ceiling and radiator, (heating and cooling) • 1-stage compressor, (heating and cooling)	ON/OFF ON/OFF ON/OFF	

**Key**

- Y1 Heating or heating / cooling valve actuator
- Y2 Cooling valve actuator
- E1 Electric heater
- M1 3- or 1-speed fan

- B1 Return air temperature sensor or external room temperature sensor (optional)
- B2 Changeover sensor (optional)

## Functions (continued)

### ADDITIONAL FUNCTIONS

#### Heating / cooling changeover via bus

The heating / cooling changeover information can be received via bus. This is only possible if the control sequence is set to automatic heating / cooling changeover (parameter P01 = 3) and no local input X1, X2 is assigned with this function.

#### KNX Heating/cooling changeover

In the absence of the required information (e.g. due to problems with data communication, power failure, etc.), the thermostat operates in the last valid room operating mode (heating or cooling).

#### Automatic heating / cooling changeover via changeover sensor

If a cable temperature sensor is connected to X1 / X2, and parameter P38 / P40 is =2, the water temperature acquired by the changeover sensor is used to change over from heating to cooling mode, or vice versa. When the water temperature is above 28 °C (parameter P37), the thermostat changes over to heating mode, and to cooling mode when below 16 °C (parameter P36).

If the water temperature is between the 2 changeover points immediately after power-up, the thermostat starts in heating mode.

The water temperature is acquired at 30-second intervals and the operating state is updated accordingly.



#### Changeover switch

The cable temperature sensor for automatic heating/cooling changeover can be replaced by an external switch for manual, remote changeover:

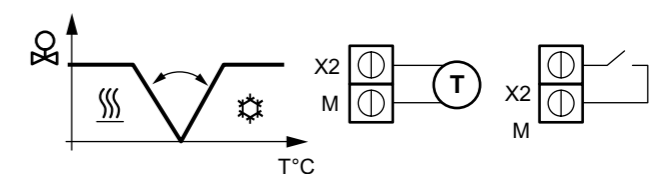

Contact open → heating mode ☷  
 Contact closed → cooling mode ☰

The sensor or switch can be connected to input terminal X2 or X1, depending on the commissioning of the inputs (P38, P40).

See also page 40 "Multifunctional input".

## Functions (continued)

### Manual heating / cooling changeover

If manual heating / cooling changeover is commissioned (P01 = 2), then heating / cooling mode cannot be changed via bus / changover sensor / switch; it will remain in the last mode as selected locally via button.

### External / return air temperature sensor

The thermostat acquires the room temperature via built-in sensor, external room temperature sensor, or external return air temperature sensor connected to multifunctional input X1 or X2.

Inputs X1 or X2 must be commissioned accordingly. See page 40 "Multifunctional input".

### Purge function

The changeover sensor ensures changeover from heating to cooling mode based on the acquired water temperature. We recommend activating the "Purge" function (parameter P50) with 2-port valves. This function ensures correct acquisition of the medium temperature even if the 2-port valve is closed for an extended period of time. The valve is then opened for 1 to 5 minutes (adjustable) at 2-hour intervals during off hours.

**CAUTION:**

The "Purge" function (parameter P50) must be disabled if the thermostat is used in compressor-based applications.

### Avoid damage from moisture

In very warm and humid climates, the fan can be run periodically or continuously at a low fan speed (e.g. in empty apartments or shops) in Economy mode by setting parameter P61, in order to avoid damage from moisture due to lack of air circulation. See also page 36 "Fan control", under "Fan kick function".

### Minimum output ON-time / OFF-time

Limit the ON/OFF switching cycle to protect the HVAC equipment, e.g. compressor and reduce wear and tear. The minimum output on-time and off-time for 2-position control output can be adjusted from 1 to 20 minutes via parameters P48 and P49. The factory setting is 1 minute.

Readjusting the setpoint or heating / cooling mode changeover immediately results in calculation of the output state; the outputs may not hold the minimum 1-minute ON/OFF time.

If parameter P48 or P49 is set to above 1 minute, the minimum ON/OFF time for the control output is maintained as set, even if the setpoint or changeover mode is readjusted.

### Floor heating / Floor cooling

All heating sequences can also be used for floor heating.

You can use fan coil unit heating / cooling sequences for floor heating or cooling by disabling the fan via parameter P52.

## Functions (continued)

### Floor temperature limitation function

The floor temperature should be limited for 2 reasons: Comfort and protection of the floor.

The floor temperature sensor, connected to multifunctional input X1 or X2, acquires the floor temperature.

If the temperature exceeds the parameterized limit (parameter P51), the heating valve is fully closed until the floor temperature drops to a level 2 K below the parameterized limit.

This function is factory-set to OFF (disabled).

Input X1 or X2 must be commissioned accordingly (P38 or P40 = 1).

See page 40 "Multifunctional input".

Recommended values for P51:

- Living rooms: Up to 26 °C for long-time presence, up to 28 °C for short-time presence.
- Bath rooms: Up to 28 °C for long-time presence, up to 30 °C for short-time presence.

The table below shows the relation between parameter, temperature source and temperature display:

Parameter P51	External temp. sensor available	Source for display of room temperature	Output control according to	Floor temp. limit function
OFF	No	Built-in sensor	Built-in sensor	Not active
OFF	Yes	External temp. sensor	External temp. sensor	Not active
10...50 °C	No	Built-in sensor	Built-in sensor	Not active
10...50 °C	Yes	Built-in sensor	Built-in sensor + limit by external sensor	Active

The "Floor temperature limitation" function influences the outputs listed in the table below:

Application	Output Y11	Output Y21	"Floor temp. limit" function has impact on output			Remark
			Heating (P01 = 0/2/3)	Cooling (P01 = 1/2/3)	Heat. and cool. (P01 = 4)	
2-pipe	H/C valve		Y11	N/A		
2-pipe & el heater	H/C valve	El heater	Y21	Y21 (*)		Only el heater
4-pipe	Heating valve	Cooling valve	Y11		Y11	

(\*) If P13 = ON → electric heater in cooling mode

**NOTE:**

Either floor temperature sensor or external room temperature sensor can be used.

## Functions (continued)

### Dew point monitoring

Dew point monitoring is essential to prevent condensation on the chilled ceiling (cooling with fan disabled, parameter P52). It helps avoid associated damage to the building.

A dew point sensor with a potential-free contact is connected to multifunctional input X1 or X2. If there is condensation, the cooling valve is fully closed until no more condensation is detected, and the cooling output is disabled temporarily.

### KNX État de défaut / Informations de défaut

The condensation symbol is displayed during temporary override and the fault "Condensation in room" will be sent via bus.

The input must be commissioned accordingly (P38, P40). See page 40 "Multifunctional input".

### Button lock

If the "Button lock" function is enabled by parameter P14, the buttons will be locked or unlocked by pressing the right button for 3 seconds.

If "Auto lock" is configured, the thermostat will automatically lock the buttons 10 seconds after the last adjustment.

## CONTROL SEQUENCES

### SEQUENCES OVERVIEW (SETTING VIA PARAMETER P01)

The main control sequence (i.e. the water coil sequence of the fan coil unit) can be set via parameter P01.

The following sequences can be activated in the thermostats (each without or with auxiliary heating).

The available sequences depend on the application (selected via DIP switch, see page 17).

## Functions (continued)

Parameter	P01 = 0	P01 = 1	P01 = 2	P01 = 3	P01 = 4
Sequence					
Available for basic application <sup>(1)</sup> :	Heating	Cooling ↳ = heating sequence for el. heater / radiator	Manually select heating or cooling sequence (using the button on the thermostat)	Automatic heating / cooling changeover via external water temperature sensor or remote switch	Heating and cooling sequence, i.e. 4-pipe
2-pipe, ↓ 2-pipe & el heater	✓	✓	✓	✓	-
4 arrivées	-	-	✓ <sup>(2)</sup>	✓ <sup>(2)</sup>	✓

### NOTES:

<sup>(1)</sup> For chilled / heated ceiling and radiator applications, see page 32; for compressor applications, see page 32.

<sup>(2)</sup> For manual and automatic changeover with 4-pipe applications, see page 30:

- 4-pipe manual changeover (P01 = 2) means activating either cooling or heating outputs
- 4-pipe automatic changeover (P01 = 3) means swapping the control outputs according to a heating / cooling sensor or remote switch ("main and secondary" application), see page 30.

For the relation between setpoints and sequences, see page 33.

## Functions (continued)

### APPLICATION MODE

#### Application mode

The behavior of the thermostat can be influenced by a building automation and control system (BACS) via bus with the command "Application mode".

With this signal, cooling and/or heating activity can be enabled or disabled.

The thermostats support the following commands:

#	Application mode	Description	Control sequence enabled
0	Auto	Thermostat automatically changes between heating and cooling	Heating and/or cooling
1	Heat	Thermostat is only allowed to heat	Heating only
2	Morning warm-up	If "Morning warm-up" is received, the room should be heated up as fast as possible (if necessary). The thermostat will only allow heating	Heating only
3	Cool	Thermostat is only allowed to provide cooling	Cooling only
4	Night purge	Not supported by fan coil applications	N/A (= Auto)
5	Pre-cool	If "Pre-cool" is received, the room should be cooled down as fast as possible (if necessary). The thermostat will only allow cooling	Cooling only
6	Off	Thermostat is not controlling the outputs, which means all outputs go to off or 0%	Neither heating nor cooling
8	Emergency heat	The thermostat should heat as much as possible. The thermostat will only allow heating	Heating only
9	Fan only	All control outputs are set to 0% and only the fan is set to high speed. Function will be terminated by any operation on the thermostat.	Run fan in high speed

With all other commands, the thermostat behaves like in Auto mode, i.e. heating or cooling according to demand.

## Functions (continued)

### Heating OR cooling

With a 2 pipe application, the control sequence state is determined by the application mode (see page 24) and by the state of the heating / cooling changeover signal (via local sensor or bus), or fixed according to the selected control sequence (P01 = heating (0) / cooling (1)).

Application mode (via bus)	State changeover / continuous heating or cooling	Control sequence on thermostat
Auto (0)	Heating	Heating
	Cooling	Cooling
Heat (1), (2), (8)	Heating	Heating
	Cooling	Cooling
Cool (3), (5)	Heating	Heating
	Cooling	Cooling
Night purge (4), Fan only (9)	Heating	Heating
	Cooling	Cooling

## Functions (continued)

### Heating AND cooling

With a 4-pipe, 2-pipe with electric heater, and 2-pipe with radiator application, the control sequence state depends on the application mode and on the heating / cooling demand.

Application Mode (via bus)	Heating / cooling demand	Control sequence on thermostat
Auto (0)	Heating	Heating
	No demand	Heating / cooling depending on last active sequence
	Cooling	Cooling
Heat (1), (2), (8)	Heating	Heating
	No demand	<b>Heating</b>
	Cooling	<b>Heating</b>
Cool (3), (5)	Heating	<b>Cooling</b>
	No demand	<b>Cooling</b>
	Cooling	Cooling
Night purge (4), Fan only (9)	No temperature control active	Heating / cooling depending on last active sequence

The value of the output as a function of the room temperature is shown in the following diagram in case of a heating and cooling system:

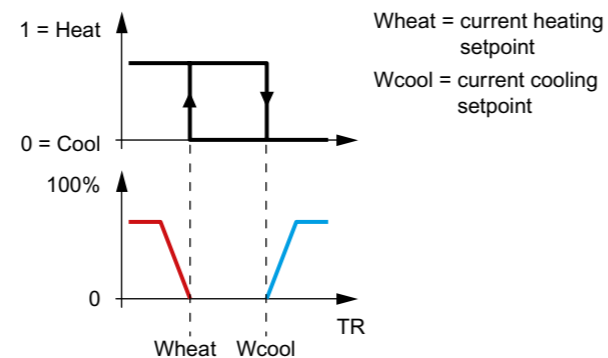

## Functions (continued)

### 2-PIPE FAN COIL UNIT

On 2-pipe applications, the thermostat controls a valve in heating / cooling mode with changeover (automatically or manually), heating only, or cooling only. Cooling only is factory-set (P01 = 1).

#### ON/OFF control

• Control sequence ON/OFF output  
The diagrams below show the control sequence for 2-position control.

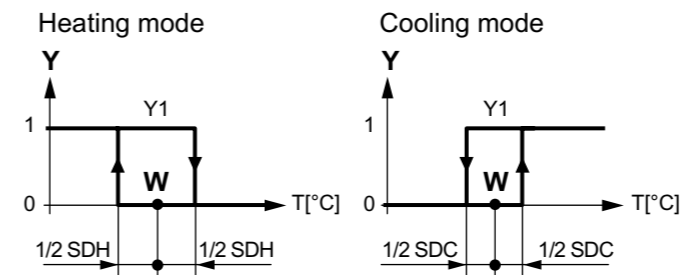

**T[°C]** Room temperature  
**W** Room temperature setpoint  
**Y1** Control command "Valve" or "Compressor"  
**SDH** Switching differential "Heating" (P30)  
**SDC** Switching differential "Cooling" (P31)

#### Modulating control: 3-position

• Control sequence modulating output  
The diagrams below show the control sequence for modulating PI control.

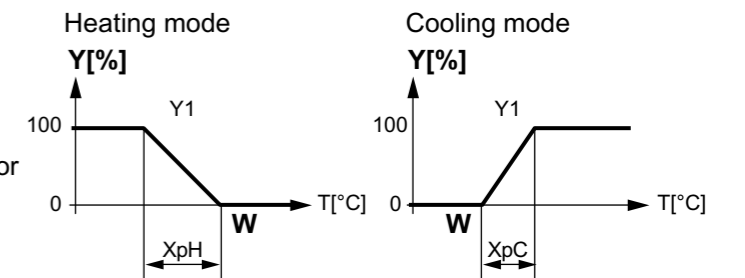

**T[°C]** Room temperature  
**W** Room temperature setpoint  
**Y1** Control command "Valve" or "Compressor"  
**XpH** Proportional band "Heating" (P30)  
**XpC** Proportional band "Cooling" (P31)

#### NOTE:

The diagrams only show the PI thermostat's proportional part.

#### Setting the sequence and the control outputs

Refer to page 17 "Applications", page 22 "Sequences", and page 35 "Outputs".

## Functions (continued)

### 2-PIPE FAN COIL UNIT WITH ELECTRIC HEATER

#### Heating or cooling with auxiliary heater

On 2-pipe applications with electric heater, the thermostat controls a valve in heating / cooling mode with changeover, heating only, or cooling only plus an auxiliary electric heater.

Cooling only is factory-set (P01 = 1) with enabled electric heater (P13).

#### Electric heating, active in cooling mode

In cooling mode, the valve receives an OPEN command if the acquired temperature is above the setpoint.

The electric heater receives an ON command if the acquired room temperature drops below "setpoint" minus "dead zone" (= setpoint for electric heater) while the electric heater is enabled (parameter P13 = ON).

**NOTE:**  
"Setpoint for electric heater" is limited by parameter "Maximum setpoint for Comfort mode" (P10).

#### Electric heating in heating mode

In heating mode, the valve receives an **OPEN** command if the acquired temperature is below the setpoint. The electric heater is used as an additional heating source when the heating energy controlled by the valve is insufficient.

The electric heater receives an **ON** command, if the temperature is below "setpoint" minus "setpoint differential" (= setpoint for electric heater).

#### Electric heating and manual changeover

The electric heater is active in heating mode only and the control output for the valve is permanently disabled when manual changeover is selected (P01 = 2).

#### Digital input "Enable electric heater"

Remote enabling / disabling of the electric heater is possible via input X1 or X2 for tariff regulations, energy savings, etc.

Input X1 or X2 must be commissioned accordingly (parameters P38, P40). See page 40 "Multifunctional input".

## Functions (continued)

### KNX Enable electric heater

The electric heater can also be enabled / disabled via bus.

**NOTE:**  
If "Enable electric heater" input is used via bus, then the function must not be assigned to a local input X1 or X2.

**CAUTION:**  
An electric heater must always be protected by a safety limit thermostat!

#### ON/OFF control

- Control sequence - ON/OFF output
- The diagrams below show the control sequence for 2-position.

Heating mode  
(automatic changeover = heating or heating only)

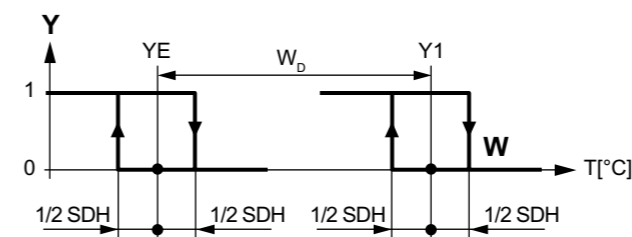

Cooling mode  
(man. / auto. changeover = cooling or cooling only)

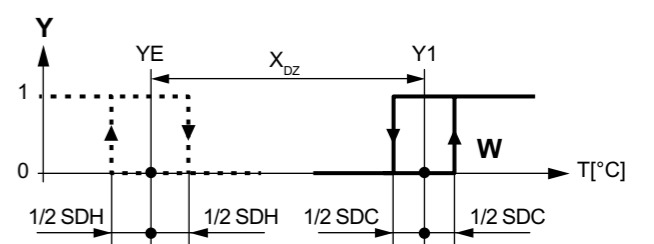

Heating mode with manual changeover (P01 = 2)  
(manual changeover = heating)

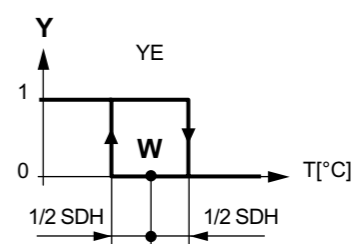

- T[°C] Room temperature
- W Room temperature setpoint
- Y1 Control command "Valve" or "Compressor"
- YE Control command "Electric heater"
- SDH Switching differential "Heating" (P30)
- SDC Switching differential "Cooling" (P31)
- X<sub>DZ</sub> Dead zone (P33)
- W<sub>D</sub> Setpoint differential (P34)

**NOTE:**  
The diagrams only show the PI thermostat's proportional part.



## Functions (continued)

### Setting the sequence and the control outputs

Refer to page 17 "Applications", page 22 "Sequences", and page 35 "Outputs".

### 4-PIPE FAN COIL UNIT

#### Heating and cooling

On 4-pipe applications, the thermostat controls 2 valves in heating and cooling mode, heating / cooling mode by manual selection, or heating and cooling mode with changeover. Heating and cooling mode (P01 = 4) is factory-set.

#### 4-pipe application with manual changeover

The heating or cooling output can be released via operating mode button if parameter P01 is set to Manual (P01 = 2).

#### "Main and secondary" application (4-pipe with changeover)

If parameter P01 is set to changeover (P01 = 3), the heating and cooling output is swapped according to the input state of the changeover sensor / switch / bus input (see automatic heating and cooling changeover sensor in page 19). This mode is used for the so-called "Main and secondary" application. This is a 4-pipe fan coil unit system with different capacities of the 2 coils. The water circuit is changed to optimize the energy exchange depending on the season (summer / winter):

- Winter: Large coil (V1) for heating, small coil (V2) for cooling
- Summer: Large coil (V1) for cooling, small coil (V2) for heating

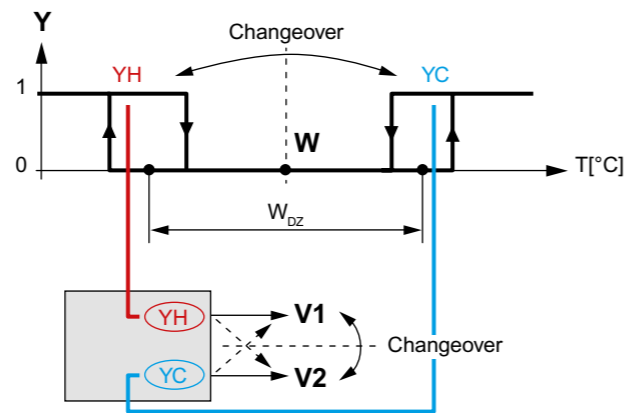
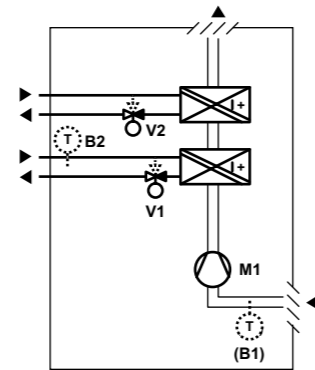

**NOTE:**  
This example shows ON/OFF control; for modulating control, connect the appropriate output terminals.

## Functions (continued)

### NOTES:

- The parameter for the heating and cooling changeover sensor (B2 in the above diagram) must be set to 2 (X1 or X2, P38 or P40)
- The thermostat assumes winter operation when  $B2 > P37$  (factory setting 28 °C)
- The thermostat assumes summer operation when  $B2 < P36$  (factory setting 16 °C)

### ON/OFF control

The diagrams below show the control sequence for 2-position control.

Heating mode with manual selection (P01 = 2)

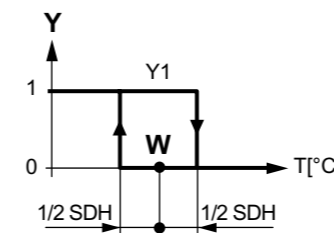

Cooling mode with manual selection (P01 = 2)

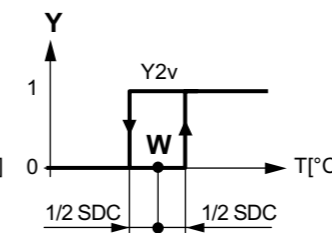

Heating and cooling mode (P01 = 04)

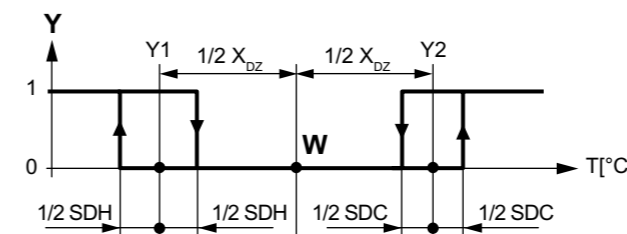

**T** [°C] Room temperature

**W** Room temperature setpoint

**Y1** Control command "Valve" or "Comp." (H)

**Y2** Control command "Valve" or "Comp." (C)

**SDH** Switching differential "Heating" (P30)

**SDC** Switching differential "Cooling" (P31)

**X<sub>DZ</sub>** Dead zone (P33)

### NOTE:

The diagrams only show the PI thermostat's proportional part.

### Setting the sequence and the control outputs

Refer to page 17 "Applications", page 22 "Sequences", and page 35 "Outputs".

## Functions (continued)

### CHILLED / HEATED CEILING AND RADIATOR APPLICATIONS

For chilled / heated ceiling and radiator,

- set the corresponding basic application
- disable the fan (P52)

The following applications are available:

Application for chilled / heated ceiling, radiator	Set basic application	See page	Sequences
Chilled / heated ceiling with changeover	2-pipe	27	H C
Chilled / heated ceiling & el heater (cooling only: disable el heater via P13)	2-pipe and electric heater	28	EI H + H (↯ \) EI H + C (↯ /) C (/)
Chilled ceiling and radiator	4-pipe	30	H + C ( \ /)

### COMPRESSOR APPLICATIONS

For compressor applications,

- set the corresponding basic application
- disable the fan (P52) or set the fan speed (P53)

The following applications are available:

Application for compressor	Set basic application	See page	Sequences
1-stage compressor for heating or cooling	2-pipe	27	H C
1-stage compressor and electric heater (for cooling only: disable electric heater via P13)	2-pipe and electric heater	28	EI H + H (↯ \) EI H + C (↯ /) C (/)
1-stage compressor for heating and cooling	4-pipe	30	H + C ( \ /)

#### NOTES:

- Minimum ON/OFF time: P48 / P49
- Fan operation: P52 (0 = disabled, 1 = enabled)
- Fan speed: P53 (1 = 1-speed, 2 = 3-speed)

## Functions (continued)

### SETPOINTS AND SEQUENCES

#### 2-pipe applications

On changeover applications, the Comfort setpoints for heating and cooling sequence are the same (w).

On 2-pipe applications with electric heater, the Comfort setpoint is either at the first heating sequence (in heating mode) or at the cooling sequence (in cooling mode).

The setpoints for Economy and Protection mode are below the Comfort setpoints (heating) and above the Comfort setpoints (cooling).

They can be set via parameters P11, P12 (Economy mode) and P65, P66 (Protection mode)

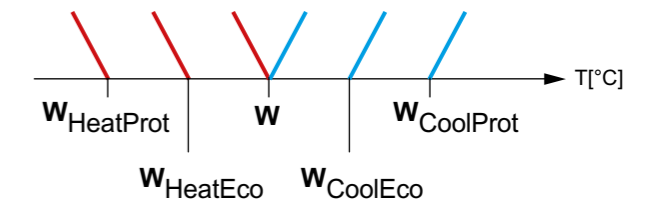

Application	Comfort mode		Economy / Protection mode	
	Heating	Cooling	Heating	Cooling
2-pipe				
2-pipe and electric heater				

<sup>(1)</sup> If P13 = ON

<sup>(2)</sup> In case of manual changeover (P01 = 2), the first heating sequence is disabled to prevent heating (electric heater) and cooling (coil) at the same time.

$W_{HeatEco/Prot}$  setpoint heating in Economy or Protection mode

$W_{CoolEco/Prot}$  setpoint cooling in Economy or Protection mode

**W** setpoint in Comfort mode

**YR** radiator sequence

**YE** electric heater sequence

## Functions (continued)

### 4-pipe applications

On 4-pipe applications, the Comfort setpoint (w) is in the middle of the dead zone, between the heating and cooling sequence.

The dead zone can be adjusted via parameter P33.

If manual changeover is selected, then either the cooling sequence or the heating sequence is released. In this case, the Comfort setpoint is at the selected heating or cooling sequence.

Application	Comfort mode			Economy / Protection mode
	Heating and cooling	Heating only <sup>(1)</sup>	Cooling only <sup>(1)</sup>	Heating and/or cooling
4-pipe				

<sup>(1)</sup> Manual changeover, P01 = 2

**W** setpoint in Comfort mode

**W<sub>HeatEco/Prot</sub>** setpoint heating in Economy or Protection mode

**W<sub>CoolEco/Prot</sub>** setpoint cooling in Economy or Protection mode

**YE** electric heater sequence

## Functions (continued)

### CONTROL OUTPUTS

#### OVERVIEW

#### Overview of control outputs

Different control output signals are available. They need to be defined during commissioning (see below).

2-position	2-position PWM	3-position	DC 0...10 V
Y11, Y21 (2 x SPST)	—	Y11, Y21 (*) (1 x ▲/▼)	—

(\*) Only on 2-pipe application

#### ON/OFF control signal (2-position)

The valve or compressor receives the **OPEN/ON** command via control output Y11 or Y21 when...

- the acquired room temperature is below the setpoint (heating mode) or above the setpoint (cooling mode).
- the control outputs have been inactive for more than the "Minimum output OFF-time" (factory setting 1 minute, adjustable via parameter P48).

**OFF** command when...

- the acquired room temperature is above the setpoint (heating mode) or below the setpoint (cooling mode).
- the valve has been active for more than the "Minimum output on-time" (factory setting 1 minute, adjustable via parameter P49).

#### Electric heater control signal (2-position)

The electric heater receives an **ON** command via the auxiliary heating control output (Y..., see Mounting Instructions) when...

- the acquired room temperature is below the "Setpoint for electric heater"
- the electric heater has been switched off for at least 1 minute

The **OFF** command for the electric heater is output when...

- the acquired room temperature is above the setpoint (electric heater)
- the electric heater has been switched on for at least 1 minute

**CAUTION:**  
safety limit thermostat (to prevent overtemperatures) must be provided externally.

## Functions (continued)

### 3-position control signal

Output Y11 provides the **OPEN** command, and Y21 the **CLOSE** command to the 3-position actuator. The factory setting for the actuator's running time is 150 seconds. It can be adjusted via parameter P44. The parameter is only visible if 3-position is selected via DIP switches.

### Synchronization

1. When the thermostat is powered up, a closing command for the actuator running time + 150% is provided to ensure that the actuator fully closes and synchronizes to the control algorithm.
2. When the thermostat calculates the positions "fully close" or "fully open", the actuator's running time is extended + 150% to ensure the right actuator position is synchronized to the control algorithm.
3. After the actuator reaches the position calculated by the thermostat, a waiting time of 30 seconds is applied to stabilize the outputs.

### Control outputs configuration (setting via DIP switches or tool)

The type of the control outputs on 2-pipe applications (2- or 3-position) is set via DIP switches (see page 17). The DIP switches have no impact if the application is commissioned via tool.

### FAN CONTROL

The fan operates in automatic mode or at the selected speed with manual mode. In automatic mode, the fan speed depends on the setpoint and the current room temperature. When the room temperature reaches the setpoint, the control valve closes and the fan switches off or stays at fan speed 1 (parameter P60; factory setting: 0 = fan speed 1 in dead zone).

#### KNX Fan command value Enable fan command value

The fan speed and mode can be changed via bus. For this purpose, the fan command value needs to be enabled

#### KNX Fonctionnement de la ventilation Étage de ventilation 1-2-3 Sortie de ventilation

The fan speed and mode can be monitored via bus.

#### • 3-speed fan control with modulating heating / cooling control

The individual switching points for ON of each fan stage can be adjusted via control parameters P55...P57. The fan speed switch off point is 20% below the switch on point. The diagrams below show fan speed control for modulating PI control.

## Functions (continued)

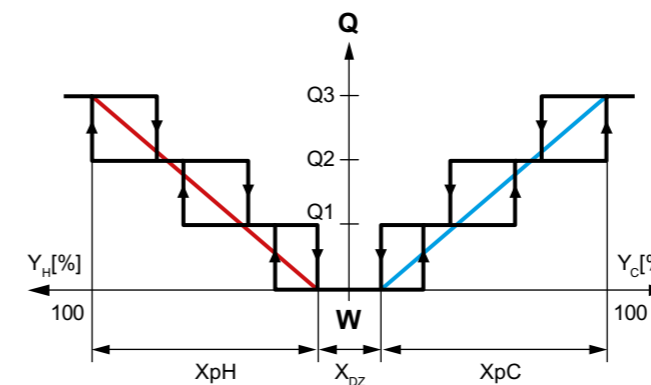

- W Room temperature setpoint
- Q Fan speed
- Y<sub>H</sub> Control demand "Heating"
- Y<sub>C</sub> Control demand "Cooling"
- X<sub>pH</sub> Proportional band "Heating"
- X<sub>pC</sub> Proportional band "Cooling"
- X<sub>Dz</sub> Dead zone

#### NOTE:

The diagram only shows the PI thermostat's proportional part.

#### • 3-speed fan control with ON/OFF heating / cooling control

On applications with 2-position control:

1. The switching point for low fan speed (Q1) is synchronized to the heating / cooling output. Parameter "Switching point fan speed low" P57 is not relevant.

2. The maximum switching range of the fan (X<sub>pHFan</sub> / X<sub>pCFan</sub>) is defined by the switching differential (SDH/SDC) via a look-up table.

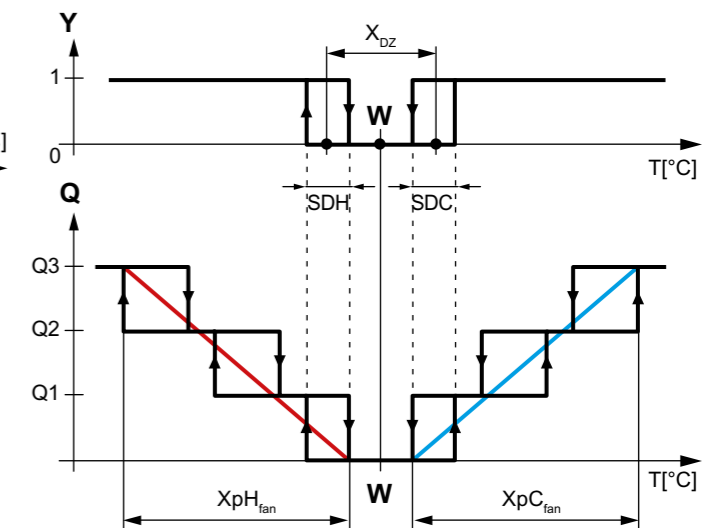

- T [°C] Room temperature
- W Room temperature setpoint
- Q Fan speed
- Y Control command "Valve"
- SDH Switching differential "Heating"
- SDC Switching differential "Cooling"
- X<sub>Dz</sub> Dead zone
- X<sub>pHFan</sub> Switching range for fan "Heating"
- X<sub>pCFan</sub> Switching range for fan "Cooling"

## Functions (continued)

Look-up table with ON/OFF control

SDH/SDC	[K]	0.5	1.0	1.5	2.0	2.5	3.0	3.5	4.0	>4.5
XpH <sub>fan</sub> /XpH <sub>fan</sub>	[K]	2	3	4	5	6	7	8	9	10

### 1-speed / 3-speed fan

The thermostat can control a 1- or 3-speed fan (selected via control parameter P53). A 1-speed fan is connected to terminal Q1, a 3-speed fan to terminals Q1, Q2 and Q3.

### Fan operation as per heating / cooling mode, or disabled

Fan operation can be limited to be active with cooling only or heating only, or even be totally disabled via control parameter "Fan operation" P52.

When fan operation is disabled, the fan symbol on the display disappears and pressing the fan button has no impact.

This function allows you to use the thermostat on universal applications such as chilled / heated ceilings and radiator, etc. (see page 32).

### Fan minimum on- time

In automatic mode, a dwelling time of 2 minutes (factory setting) is active. The fan maintains each speed for at least 2 minutes before it changes to the next speed.

This minimum on-time can be adjusted from 1...6 minutes via parameter P59.

In automatic fan mode and with the room temperature in the dead zone, the control valve is normally closed and the fan disabled. With the "Fan kick" function, the fan can be released from time to time at low speed for minimum on-time (see above) even if the valve is closed.

This function can be used to avoid damage from moisture due to a lack of air circulation, or to allow a return air temperature sensor to acquire the correct room temperature.

### Fan operation in dead zone (fan kick)

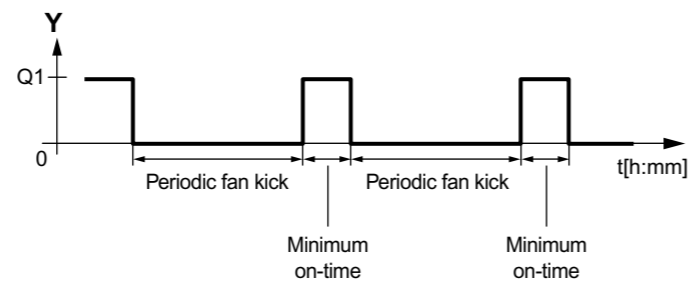

The periodic fan kick time can be selected individually for Comfort mode via parameter P60, and for Economy mode via parameter P61.

#### NOTE:

Fan kick value "0" means the fan runs continuously in the dead zone.

Fan kick value "OFF" means the fan does not run in the dead zone.

## Functions (continued)

### Fan start

When the fan starts from standstill, it starts at speed 3 for 1 second to ensure safe fan motor start by overcoming inertia and friction (selected via parameter P58).

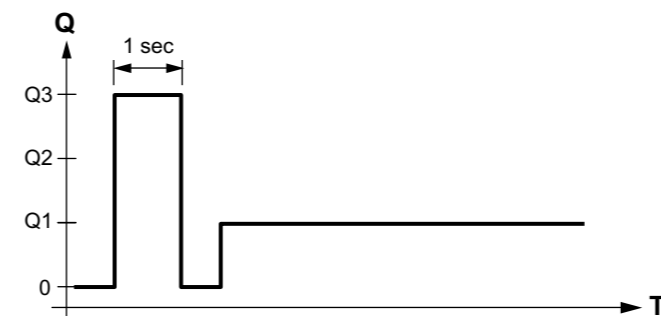

### Fan overrun for electric heater

When the electric heater is switched off, the fan overruns for 60 seconds (parameter P54) to avoid overtemperature of the electric heater or prevent the thermal cutout from responding.

#### FAN FAILURE:

In case of fan failure, the thermostat cannot protect the electric heater against overtemperature. For this reason, the electric heater must feature a separate safety device (thermal cutout).

### Clean fan filter reminder

The "Clean fan filter reminder" function counts the fan operating hours and displays message "FIL" to remind the user to clean the fan filter as soon as the threshold is reached. This does not impact the thermostat's operation, which continues to run normally.

#### KNX Fault information

The "Clean filter reminder" is reset when the operating mode is manually set to Protection and back.

### Fan in Auto Timer mode

In Auto Timer mode  $\text{Auto}$ , the default fan mode is automatic. The fan mode can be changed to Manual by pressing the FAN button. The fan returns to the automatic default mode after each switchover from Comfort to Economy mode, and vice versa.

## Functions (continued)

### MULTIFUNCTIONAL INPUT, DIGITAL INPUT

The thermostat has 2 multifunctional inputs X1 and X2. An NTC type sensor (AI, analog input) or a switch (DI, digital input) can be connected to the input terminals. The functionality of the inputs can be configured via

parameters P38 + P39 for X1 and P40 + P41 for X2. The current temperature or state of the inputs X1/X2 is available on bus for monitoring purposes. The parameters can be set to the following values:

#	Function of input	Description	Type X1/X2
0	Not used	No function.	—
1	External / return air temperature	Sensor input for external room temperature sensor or return air temperature sensor to acquire the current room temperature, or floor heating temperature sensor to limit the heating output. <b>NOTE:</b> The room temperature is acquired by the built-in sensor if the floor temperature limitation function is enabled via parameter P51.	AI
2	Heating / cooling changeover	Sensor input for "Automatic heating / cooling changeover" function. A switch can also be connected rather than a sensor (switch closed = cooling, see page 19). Heating / cooling changeover is also possible via bus. In this case, the function must not be assigned to any local input X1, X2.	AI / DI
3	Operating mode switchover	Digital input to switch over the operating mode to Economy. If the operating mode switchover contact is active, user operations are ineffective and "OFF" is displayed. Operating mode switchover is also possible via bus. In this case, the function must not be assigned to any local input X1, X2. See also page 6.	DI
4	Dew point monitor	Digital input for a dew point sensor to detect condensation. Cooling is stopped if condensation occurs.	DI

## Functions (continued)

#	Function of input	Description	Type X1/X2
5	Enable electric heater	Digital input to enable / disable the electric heater via remote control. Enable electric heater is also possible via bus. In this case, the function must not be assigned to any local input X1, X2. See also page 22.	DI
6	Fault	Digital input to signal an external fault (example: dirty air filter). If the input is active, "ALx" is displayed and a fault is sent on the bus. See also page 43. (Alarm x, with x = 1 for X1, x = 2 for X2). <b>NOTE:</b> Fault displays have no impact on the thermostat's operation. They merely represent a visual signal.	DI
7	Monitor input (Digital)	Digital input to monitor the state of an external switch via bus.	DI
8	Monitor input (Temperature)	Sensor input to monitor the state of an external sensor via bus.	AI

- Operational action can be changed between normally open (NO) and normally closed (NC) via parameter P39, P41.
- Each input X1 or X2 must be configured with a different function (1...5). Exception: 1 or 2 inputs can be configured as fault (6) or monitor input (7,8).

- X1 is factory-set to "Operating mode switchover" (3), X2 to "External sensor" (1). For more detailed information, refer to page 17 "Applications".

## Functions (continued)

### HANDLING FAULTS

#### Temperature out of range

When the room temperature is outside the measuring range, i.e. above 49 °C or below 0 °C, the limiting temperatures blink, e.g. "0 °C" or "49 °C".

In addition, the heating output is activated if the current setpoint is not set to "OFF", the thermostat is in heating mode and the temperature is below 0 °C.

For all other cases, no output is activated.

The thermostat resumes Comfort mode after the temperature returns to within the measuring range.

For fault status messages on the bus, see page 43.

### KNX COMMUNICATIONS

The thermostats support communications as per the KNX specification.

S-mode → Standard mode: engineering via group addresses.

#### S-mode

This mode corresponds to KNX communications.

Connections are established via ETS Professional by assigning communication objects to group addresses.

#### Send heartbeat and receive timeout

In a KNX network, S-mode communication objects can be exchanged between individual devices. The Receive timeout defines the period of time within which all the communication objects requested from a device must have been received at least once. If a communication object is not received within this period, a predefined value is used.

Similarly, the Send heartbeat defines the period of time within which all the communication objects requested must be transmitted at least once.

Fixed times are specified as follows:

- Receive timeout: 31 minutes
- Send heartbeat: 15 minutes

## Functions (continued)

### Reducing the bus load

Individual zones can also be disabled (out of service) via control parameter if they are not being used. In disabled zones, the signal will no longer be periodically sent, and will therefore reduce bus load.

### Startup

#### • Startup response

The application is restarted after every reset, so that all the connected motorized valve actuators are synchronized (see "Control outputs", 3.7).

#### • Startup delay

After a reset, it takes up to 5 minutes for all the connected room thermostats to restart. This is designed to avoid overloading the mains power supply when restarting. At the same time, it reduces the load on the KNX network, as not all thermostats transmit data at the same time. The delay (TWaitDevice) is determined by the thermostat's device address. After the delay, the device starts to send.

### Heating and cooling demand

Heating output primary  
Heating output secondary  
Cooling output primary

In S-mode, the current state signals of the control outputs are available.

### Fault function on KNX

If a fault occurs (e.g. digital fault input, dew point, communication configuration, etc.) then a fault will be sent on the bus.

An thermostat listens on the bus and sends its fault when the fault has the highest alarm priority. This ensures that the management station does not miss any alarms. If alarms occur at the same time, the alarm with the highest priority will be first displayed and sent on the bus.

The table below shows the error code and default alarm texts.

Prio.	Fault	Thermostat	Fault information on bus	
		Display	Error code	Default fault text
-	No fault	—	0	No fault
1	Bus power supply (**)	🔔 BUS	5000	No BUS power supply
2	Device address error	🔔 Addr	6001	>1 id device address
3	Condensation		4930	Condensation in the room
4	External fault input X1	🔔 AL1	9001	Fault input 1
5	External fault input X2	🔔 AL2	9002	Fault input 2
6	Clean filter reminder	🔔 FIL	3911	Dirty filter

(\*\*) This error will not be sent on bus (because there is no bus!)

## Functions (continued)

### Priority of alarms

- Priority order is #1...6
- External faults #4...5: If faults are active, the display will show AL1, AL2, alternating. On the bus, only the fault with the highest priority will be sent.

### Fault transmission

A supervisor alarm system may command the thermostat to stop sending faults to the bus via the communication object "Fault transmission" (disable / enable).

This has no impact on the local display of faults.

After a timeout of 48 hours, the sending of faults will automatically be enabled again.

## Functions (continued)

### COMMUNICATION OBJECTS (S-MODE)

#### Overview

Page	Object # and name	Thermostat	Object # and name	Page
5	1 System time	→		
5	3 Time of day	→		
5	44 Outside temperature	→		
7	12 Room operating mode: Time switch <sup>(1)</sup>	→	→ 21 Room temperature	5
7	7 Room operating mode: Preselection <sup>(1)</sup>	↔	→ 16 Room operating mode: State <sup>(1)</sup>	6
6, 8, 40	20 Room operating mode: Window state	→	→ 24 Room temperature: Current setpoint	16
15	22 Room temperature: Comfort basic setpoint	→	→ 33 Fan operation (0 = Auto / 1 = Manual)	37
15	23 Room temperature: Comfort setpoint	↔	→ 35 Fan output	37
24	31 Application mode	→	→ 36 Fan stage 1	37
37	32 Enable fan command value	→	→ 37 Fan stage 2	37
37	34 Fan command value	→	→ 38 Fan stage 3	37
			→ 25 Heating output primary <sup>(2)</sup>	43
			→ 26 Heating output secondary <sup>(2)</sup>	43
			→ 27 Cooling output primary <sup>(2)</sup>	43



## Functions (continued)

Page	Object # and name	Thermostat	Object # and name	Page
28, 43	29 Enable electric heater	→		
19, 43	30 Heating/cooling changeover	→	→ 39/40 X1 (temperature / digital) → 41/42 X2 (temperature / digital)	41 41
44	6 Fault transmission	→	→ 5 Fault state → 4 Fault information	21, 43 21, 39, 42, 44

→ Input communication object  
 → Output communication object  
 ↔ Input & output communication object

(1) 8-bit and 1-bit object available, selectable via parameter in ETS  
 (2) Availability depending on selected application / function

## Functions (continued)

### Description of communication objects

Obj.	Object name	Function	Type/length	Flags
1	System time	Time and date	19.001 8 Byte	CWU
System time for display on the room thermostat. See parameter P07 (3 or 4)				
3	Time of day	Time and date	10.001 3 Byte	CWU
Another object for receiving the time of day for display on the room thermostat. See parameter P07 (3 or 4)				
4	Fault information	Alarm Info	219.001 6 Byte	CT
Common alarm output. If an alarm occurs, the alarm number is transmitted				
5	Fault state	Faulty / normal	1.005 1 bit	CT
Common alarm output. If an alarm occurs, the alarm flag is set				
6	Fault transmission	Enable / disable	1.003 1 bit	CWU
A supervisor alarm system can disable the broadcasting of alarms by the devices. This has no impact on the local display of alarms. After a timeout of 48 hours, the sending of faults will automatically be enabled again.				

Obj.	Object name	Function	Type/length	Flags
7	Room operating mode: Preselection	Auto Comfort PreComf. Economy Protection	20.102 1 Byte	CWTU
Controls the room operating mode selection of the thermostat via bus. The command can also be submitted as four 1-bit communication objects (8...11). The last interaction wins – either from local operating mode button or via bus. <b>NOTE:</b> The thermostat will transform Precomfort either into Economy or Comfort (selectable via P88).				
8	Operating mode: Preselection	Trigger	1.017 1 bit	CW
9	Auto Comf			
10	Eco Prot			
11				
Switch room operating mode to either Auto, Comfort, Economy or Protection. The last interaction wins – either from the local operating mode button or via bus.				

## Functions (continued)

Obj.	Object name	Function	Type/length	Flags
12	Room operating mode: Time switch	Comfort Economy PreComf. Protection	20.102 1 Byte	CWU

This information is provided by a central time switch or a supervisor and defines the actual HVAC operating mode. The command can also be submitted via three 1-bit communication objects (13...15).

Protection has the highest priority and cannot be overridden.

**NOTE:** The thermostat will transform Precomfort either into Economy or Comfort (selectable P88).

13	Time switch	Trigger	1.017 1 bit	CW
14	Comfort Economy			
15	Protection			

Switch the HVAC mode to either Comfort, Economy or Protection mode.

16	Room operating mode: State	Comfort Economy Protection	20.102 1 Byte	CRT
----	----------------------------	----------------------------------	------------------	-----

Effective room operating mode used by the thermostat (considering time switch, user selection, window contact, etc.) This state information is available via one 8-bit enumeration or three 1-bit communication objects (17...19). Note: The thermostat does not support Precomfort.

Obj.	Object name	Function	Type/length	Flags
17	Room operating mode:	ON	1.002 1 bit	CT
18	State Comfort	OFF		
19	State Economy State Protection			

Corresponding communication object sends "True".

20	Window state	Open Closed	1.019 1 bit	CWU
----	--------------	----------------	----------------	-----

The thermostat is set to Economy mode if value "1" (open) is received. It switches back to the previous mode when the value is "0" (closed).

"Window state" is sent e.g. by a KNX switch or a KNX presence detector. It has the same effect as the local operating mode switchover contact X1, X2 (parameter P38, P40).

Only one input source must be used, either local input X1/X2 or KNX bus. .

21	Room temperature	Temp. value	9.001 2 Bytes	CRT
----	------------------	-------------	------------------	-----

The value of the room temperature measured via built-in or external sensor is available via this communication object.

## Functions (continued)

Obj.	Object name	Function	Type/length	Flags
22	Room temperature: Comfort basic setpoint	Temp. value	9.001 2 Bytes	CWU

If function "Temporary setpoint" is enabled via parameter P69, then after an operating mode change, the setpoint adjustments made by the user and via communication object 23 will be dismissed and the thermostat will be reset to the Comfort basic setpoint.

**NOTE:** Setpoints that have been changed via the local HMI may be overwritten during a system startup from a central master controller.

The Comfort basic setpoint is stored in EEPROM (see page 15) → The service life of the EEPROM depends on the number of write cycles. Never write this communication object cyclically!

23	Room temperature: Comfort setpoint	Temp. value	9.001 2 Bytes	CWTU
----	------------------------------------	-------------	------------------	------

Communication object used to shift the setpoint used by the thermostat (voir page 15). Same priority as local setpoint shift on the thermostat. The last intervention wins.

**NOTE:** The Comfort basic setpoint (object 22) will not be changed.

Obj.	Object name	Function	Type/length	Flags
24	Current setpoint	Temp. value	9.001 2 Bytes	CRT

Current setpoint, including shift, compensation, etc., used by the thermostat for temperature control.

25	Heating output primary	0...100 %	5.001 8 bit	CRT
----	------------------------	-----------	----------------	-----

Indicates the position of the heating actuator of first stage.

E.g. 2-pipe with electric heater application: Output of heating coil.

26	Heating output secondary	0...100 %	5.001 8 bit	CRT
----	--------------------------	-----------	----------------	-----

Indicates the position of the heating actuator of the second stage. E.g. 2-pipe with electric heater application: Output of the electric heater.

27	Cooling output primary	0...100 %	5.001 8 bit	CRT
----	------------------------	-----------	----------------	-----

Indicates the position of the cooling actuator of the first stage. E.g. 2-pipe with electric heater application: Output of the cooling coil.

## Functions (continued)

Obj.	Object name	Function	Type/ length	Flags
29	Enable electric heating	Enable / disable	1.003 1 bit	CWU

An electric heater can be disabled with this communication object (e.g. to meet tariff regulations). The same function is also available via local multifunctional input X1/X2 (parameter P38, P40).

Only one input source must be used, either local input X1/X2 or KNX bus.

Obj.	Object name	Function	Type/ length	Flags
30	Heating / cooling changeover	Heat / Cool	1.100 1 bit	CWU

Changeover information transmitted via bus. Default: Current mode before power down.

The same function is also available via local multifunctional input X1/X2 (parameter P38, P40).

Only one input source must be used, either local input X1/X2 or KNX bus.

Obj.	Object name	Function	Type/ length	Flags
31	Application mode	HVAC control mode	20.105 8 bit	CWU
0	Auto (default)	Heating and/or cooling		
1	Heat	Heating only		
2	Morning warmup*	Heating only		
3	Cool	Cooling only		
5	Precool*	Cooling only		
6	OFF	Neither heating nor cooling		
8	Emergency heat*	Heating only		
9	Fan only	Fan runs at high speed		

\* Function handled like Heat (1) or Cool (3)

Obj.	Object name	Function	Type/ length	Flags
32	Enable fan command value	Enable / Disable	1.003 1 bit	CWU

Set fan mode to Auto (disable) or Manual (enable) by a KNX control unit. If Manual, the value received on Fan command value (34) will be used to command the fan speed.

Default: Enable

The last interaction wins – either from the local fan mode button or via bus.

Obj.	Object name	Function	Type/ length	Flags
33	Fan operation	Auto / Manual	1.001 1 bit	CRT

Indicates the status of the fan mode: Auto <sup>(0)</sup> or Manual <sup>(1)</sup>.

Obj.	Object name	Function	Type/ length	Flags
34	Fan command value	0...100 %	5.001 8 bit	CWU

The fan can be set to a specified speed by a KNX control unit when manual fan operation is enabled.

Speed	Fan command value (physical KNX value)
1	1...33% (1...85)
2	34...67% (86...170)
3	68...100% (171...255)

Fan speed "0" is not supported by the thermostat and the fan speed will remain unchanged.

## Functions (continued)

Obj.	Object name	Function	Type/ length	Flags
35	Fan output	0...100%	5.001 8 bit	CRT

Indicates the current fan speed as a value 0...100%.

Speed	Fan output (physical KNX value)
OFF	0% (0)
1	33% (84)
2	66% (186)
3	100% (255)

Obj.	Object name	Function	Type/ length	Flags
36	Fan speed 1	ON	1.001	CRT
37	Fan speed 2	OFF	1 bit	
38	Fan speed 3			

Indicate the state of the relay outputs.

Obj.	Object name	Function	Type/ length	Flags
39	X1: Temperature	Temp. value	9.001	CRT
40	X2: Temperature		2 Byte	

Indicate the values of the temperature sensors connected to the local inputs X1 / X2

Obj.	Object name	Function	Type/ length	Flags
41	X1: Digital	ON	1.001	CRT
42	X2: Digital	OFF	1 bit	

Indicate the status of the digital inputs (adjusted by parameters P39/P41) including considering of operating action.

Obj.	Object name	Function	Type/ length	Flags
44	Outside temperature	Temp. value	9.001 2 Byte	CWU

The outside temperature measured by a KNX sensor can be displayed on the thermostat, if parameter P07 "Additional user information" is set = 2 (outside temperature).

### CONTROL PARAMETERS

A number of control parameters can be readjusted to optimize control performance. This can be done on the thermostat via HMI or via commissioning / operating tool. These parameters can also be set during operation without opening the unit.

In the event of a power failure, all control parameter settings are retained.

The control parameters are assigned to 2 levels:

- "Service level", and
- "Expert level" including communications, diagnostics and test.

The "Service level" contains a small set of parameters to set up the thermostat for the HVAC system and to adjust the user interface. These parameters can be adjusted any time.

Change parameters at the "Expert level" carefully, as they impact the thermostat's control performance and functionality.

#### Parameter setting via local HMI

##### • Enter only "Service" level

1. Press buttons + and – simultaneously for 3 seconds. Release and press button + again for 3 seconds within 2 seconds. The display shows "P01". Continue with step 2.

##### • Enter "Service" and "Expert" level

1. Press buttons + and – simultaneously for 3 seconds. Release and press button – again for 3 seconds within 2 seconds. The display shows "P01" and service.

## Functions (continued)

### • Adjust parameters

2. Repeatedly press the + or – button to select the required parameter.

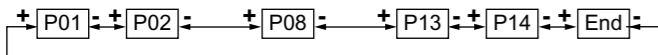

3. Press + and – simultaneously. The current value of the selected parameter begins to flash, allowing you to change the value by repeatedly pressing + or –.
4. The next parameter is displayed when you press + and – again simultaneously.
5. Repeat steps 2 to 4 to display and change additional parameters.
6. Press + or – until "End" is displayed, and then press + and – simultaneously to save the change and exit parameter entry mode.

### • Reset parameters

The factory setting for the control parameters can be reloaded via parameter P71, by changing the value to "ON", and confirming by pressing buttons + and – simultaneously. The display shows "8888" during reload.

### Parameter setting / download via tool



#### ETS Professional

Control parameters can be adjusted via local HMI or bus via ETS by parameter download during commissioning.

#### NOTE:

The KNX thermostats require version ETSf or higher.

### Connecting a KNX tool

Connecting a KNX commissioning / operating tool to the is described in page 60.

## Functions (continued)

### Parameters of the "Service level"

Parameter	Service level	Factory setting	Range
P01	Control sequence	2-pipe: 1 = Cooling only 4-pipe: 4 = Heating and Cooling	0 = Heating only 1 = Cooling only 2 = H/C changeover manual 3 = H/C changeover auto 4 = Heating and Cooling
P02	Operation via room op selector	1	1 = Auto – Protection 2 = Auto - Comfort - Economy - Protection
P04	Unit	C (0)	C = ° Celsius F = ° Fahrenheit
P05	Measured value correction	0 K	– 3 ... 3 K
P06	Standard display	0	0 = Room temperature 1 = Setpoint
P07	Additional display information	0	0 = --- (No display) 1 = °C and °F 2 = Outside temperature (via bus) 3 = Time of day (12h) (via bus) 4 = Time of day (24h) (via bus)
P08	Comfort basic setpoint	21 °C	5 ... 40 °C
P09	Comfort setpoint minimum	5 °C	5 ... 40 °C
P10	Comfort setpoint maximum	35 °C	5 ... 40 °C
P11	Economy heating setpoint	15 °C	OFF, 5 ... WCoolEco; WCoolEco = 40 °C max
P12	Economy cooling setpoint	30 °C	OFF, WHeatEco ... 40 °C; WHeatEco = 5C min

## Functions (continued)

Parameter	Service level	Factory setting	Range
P13	Electric heater when cooling	ON	ON: Enabled OFF: Disabled
P14	Button lock	0	0 = Unlocked 1 = Auto lock 2 = Manual lock

**NOTE:**  
Parameter display depends on selected application and function.

### Parameters of the "Expert level with diagnostics and test"

Parameter	Expert level	Factory setting	Range
P30	Heat P-band Xp / switching diff	2 K	0.5 ... 6 K
P31	Cool P-band Xp / switching diff	1 K	0.5 ... 6 K
P33	Dead zone Comfort mode	2 K	0.5 ... 5 K
P34	Setpoint differential	2 K	0.5 ... 5 K
P35	Integral action time Tn	5 min	0...10 min
P36	H/C ch'over swi point cooling	16 °C	10...25 °C
P37	H/C ch'over swi point heating	28 °C	27...40 °C

## Functions (continued)

Parameter	Expert level	Factory setting	Range
P38	Input X1	3 = Op mode c/o	0 = --- (no function) 1 = Room temp ext. sensor / Return air temp (AI) 2 = H/C changeover (AI/DI) 3 = Operating mode contact (DI) 4 = Dew point sensor (DI) 5 = Enable electric heater (DI) 6 = Fault input (DI) 7 = Monitor input (Digital) 8 = Monitor input (Temp)
P39	Normal position input X1	0 (N.O.)	0 = Normally open / Open 1 = Normally closed / Close
P40	Input X2	1 = Ext. sensor	0 = --- (no function) 1 = Room temp ext. sensor / Return temp (AI) 2 = H/C changeover (AI/DI) 3 = Operating mode contact (DI) 4 = Dew point sensor (DI) 5 = Enable electric heater (DI)
P41	Normal position input X2	0 (N.O.)	0 = Normally open / Open 1 = Normally closed / Close
P44	Actuator running time Y11/Y21	150 s	20...300 sec
P46	Output Y11/Y21	ON/OFF <sup>(1)</sup>	0 = 3-position 1 = 2-position
P48	On time minimum 2-pos output	1 min.	1...20 min
P49	Off time minimum 2-pos output	1 min.	1...20 min
P50	Purge time	OFF	OFF: Not active 1...5 min: Active with selected duration
P51	Flow temp limit floor heating	OFF	OFF, 10...50 °C

## Functions (continued)

Parameter	Expert level	Factory setting	Range
P52	Fan control	1	0 = Disabled 1 = Enabled 2 = Heating only 3 = Cooling only
P53	Fan speeds	3-speed	1 = 1-speed 2 = 3-speed
P54	Fan overrun time	60 sec	0...360 sec
P55	Fan speed switching point high	100%	80...100%
P56	Fan speed switching point med	65%	30..75%
P57	Fan speed switching point low	10%	1...15%
P58	Fan start kick	ON	ON: Enabled OFF: Disabled
P59	On time minimum fan	2 min	1...6 min
P60	Periodic fan kick Comfort	0	0...89 min, OFF(90)
P61	Periodic fan kick Eco	OFF	0...359 min, OFF(360)
P62	Service filter	Off (0)	Off, 100...9900 h
P65	Protection heating setpoint	8 °C	OFF, 5...WCoolProt; WCoolProt = 40 °C max
P66	Protection cooling setpoint	OFF	OFF, WHeatProt... 40; WHeatProt = 5 °C min
P68	Temporary Comfort mode	0 (= OFF)	0...360 min
P69	Temporary Comfort setpoint	OFF	OFF = Disabled ON = Enabled
P71	Restore factory setting	OFF	OFF = Disabled ON = Reload start "8888" is displayed for 3s during reload process

## Functions (continued)

Parameter	Communications	Factory setting	Range
P81	Device address <sup>(1)</sup>	255	1...255
P83	Geographical zone (room)	1	---, 1...63
P84	Heat distr zone heating coil	---	---, 1...31
P85	Refrig distr zone cooling coil	---	---, 1...31
P88	Transformation Precomfort	0	0 = Economy 1 = Comfort

<sup>(1)</sup> Physical address = Area.Line.DeviceAddress. Factory setting for Area = 0, Line = 2s.

Can be changed by special management service e.g. from line coupler or via ACS commissioning tool.

<sup>(2)</sup> Type = geographical zone A.R.S. In sub zone = fixed value 1

## Functions (continued)

Parameter	Diagnostics & test	Range
d01	Application number	NONE = (No application) 2P = 2-pipe 2P3P = 2-pipe 3-position 2PEH = 2-pipe with electric heater 4P = 4-pipe
d02	X1 state	0 = Not activated (for DI) 1 = Activated (DI) 0...49 °C = Current temp. value (for AI) 00 = H/C Input shorted 100 = H/C Input open
d03	X2 state	0 = Not activated (for DI) 1 = Activated (DI) 0...49 °C = Current temp. value (for AI) 00 ⚙ = H/C Input shorted 100 ))) = H/C Input open
d05	Test mode for checking the Y11/Y21 actuator's running direction <sup>(3)</sup>	"---" = no signal on outputs Y11 and Y21 OPE = output Y11 forced opening

<sup>(3)</sup> This parameter can only be quit when the setting is back at "---". Press buttons + and – simultaneously to escape.

## Handling

### MOUNTING AND INSTALLATION

Mount the room thermostat on a recessed rectangular conduit box with 60.3 mm fixing centers. Do not mount on a wall in niches or bookshelves, behind curtains, above or near heat sources, or exposed to direct solar radiation. Mount about 1.5 m above the floor.

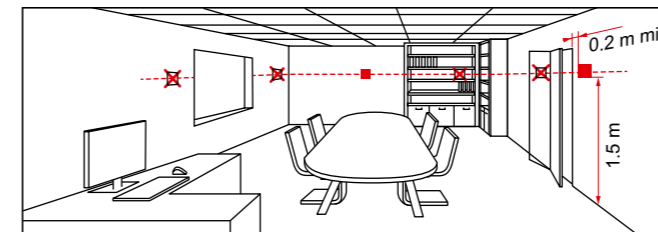

#### Mounting

- Mount the room thermostat in a clean, dry indoor place without direct airflow from a heating / cooling device, and not exposed to dripping or splash water.

#### Wiring

- Comply with local regulations to wire, fuse and earth the thermostat.
- Properly size the cables to the thermostat, fan and valve actuators for AC 230 V mains voltage.
- Use only valve actuators rated for AC 230 V.
- The AC 230 V mains supply line must have an external fuse or circuit breaker with a rated current of no more than 6 A.

- Isolate the cables of SELV inputs X1-M/X2-M for 230 V if the conduit box carries AC 230 V mains voltage.
- Inputs X1-M or X2-M: Several switches (e.g. summer / winter switch) may be connected in parallel. Consider overall maximum contact sensing current for switch rating.
- Isolate the cables of KNX communication input CE+ / CE- for AC 230 V if the conduit box carries AC 230 V mains voltage.
- No metal conduits.
- No cables provided with a metal sheath.
- Disconnect from supply before opening the cover.

## Handling (continued)

### COMMISSIONING

#### Applications

The room thermostats are delivered with a fixed set of applications.

Select and activate the relevant application during commissioning using one of the following tools:

- Local DIP switch and HMI
- ETS Professional

#### DIP switches

Set the DIP switches before snapping the front panel to the mounting plate, if you want to select an application via DIP switches.

All DIP switches need to be set to "OFF" (remote configuration), if you want to select an application via commissioning tool.

After power is applied, the thermostat resets and all LCD segments flash, indicating that the reset was correct. After the reset, which takes about 3 seconds, the thermostat is ready for commissioning by qualified HVAC staff.

If all DIP switches are OFF, the display reads "NONE" to indicate that application commissioning via a tool is required.

**NOTE:**  
Each time the application is changed, the thermostat reloads the factory setting for all control parameters, except for KNX device and zone addresses!

#### Connect tool

Connect the ETS Professional tools to the KNX bus cable at any point for commissioning:

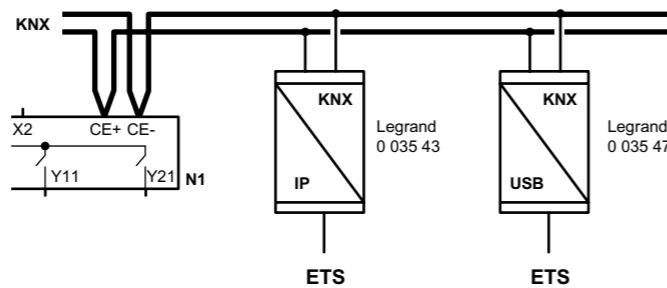

ETS require an interface:  
- Serial or IP KNX interface

**NOTE:**  
An external KNX bus power supply is required if a thermostat is connected directly to a tool (ETS) via KNX interface.

#### Control parameters

The thermostat's control parameters can be set to ensure optimum performance of the entire system.

The parameters can be adjusted using  
- Local HMI  
- ETS Professional

The control parameters of the thermostat can be set to ensure optimum performance of the entire system (see page 51, control parameters).

## Handling (continued)

#### Control sequence

- The control sequence may need to be set via parameter P01 depending on the application. The factory setting is as follows:

Application	Factory setting P01
2-pipe and chilled / heated ceiling	1 = cooling only
4-pipe, chilled ceiling and radiator	4 = heating and cooling

#### Compressor-based applications

- When the thermostat is used with a compressor, adjust the minimum output on-time (parameter P48) and OFF-time (parameter P49) for Y11/Y21 to avoid damaging the compressor or shortening its life due to frequent switching.

#### Calibrate sensor

- Recalibrate the temperature sensor if the room temperature displayed on the thermostat does not match the room temperature measured (after min. 1 hour of operation). To do this, change parameter P05.

#### Setpoint and range limitation

- We recommend to review the setpoints and setpoint ranges (parameters P08...P12) and change them as needed to achieve maximum comfort and save energy.

#### Programming mode

The programming mode helps identify the thermostat in the KNX network during commissioning.

Press buttons "operating mode" and "+" simultaneously for 6 sec to activate programming mode, which is indicated on the display with "PrOg". Programming mode remains active until thermostat identification is complete.

#### Assign KNX group addresses

Use ETS Professional to assign the KNX group addresses of the thermostat's communication objects.

#### KNX serial number

Each device has a unique KNX serial number inside the front panel. An additional sticker with the same KNX serial number is enclosed in the packaging box. This sticker is intended for installers for documentation purposes.

#### Assign KNX device address

Assign device address (P81) via HMI or ETS.

With device address set to 255, the communication is deactivated (no exchange of process data).



## Handling (continued)

### OPERATION

#### LAYOUT

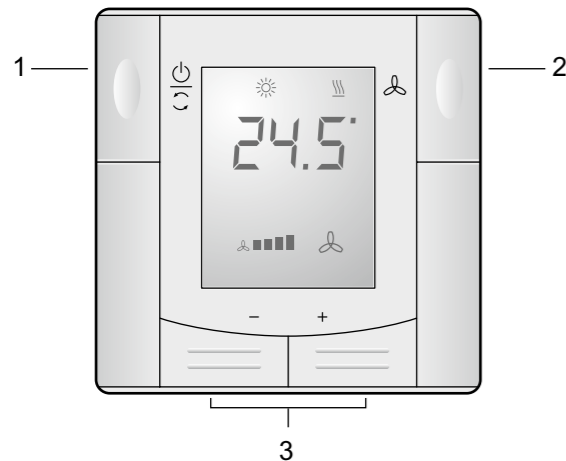

- 1 Operating mode selector
- 2 Button to change fan operation
- 3 Buttons to adjust setpoints and control

#### BUTTON OPERATION

User action	Effect, description
Normal operation	Actual operating mode and state are indicated by symbols
Press any button (thermostat in normal operation)	Backlit LCD turns on and... (see below for further action). After the last operation and a timeout of 20 seconds, the LCD backlight turns off

User action	Effect, description
Press left button	Change operating mode
Press left button (P01 = 2)	Toggle between heating and cooling
Press left button while "Operating mode switchover" via bus is activated	Activate "Extend Comfort mode" (for details, see page 16)
Press left button >5 seconds	Activate / deactivate button lock
Press right button	Change fan mode
Press + or -	Adjusts the Comfort room temperature setpoint . Thermostat changes to Comfort mode.
Press + and - >3 seconds, release, then press + again >3 seconds	Go to parameter setting mode "Service level"
Press + and - >3 seconds, release, then press - again >3 seconds	Go to parameter setting mode "Expert level", diagnostics and test
Press operating mode button and "+" simultaneously for 6 seconds	Accès au mode de programmation (KNX)

## Handling (continued)

### DISPLAY

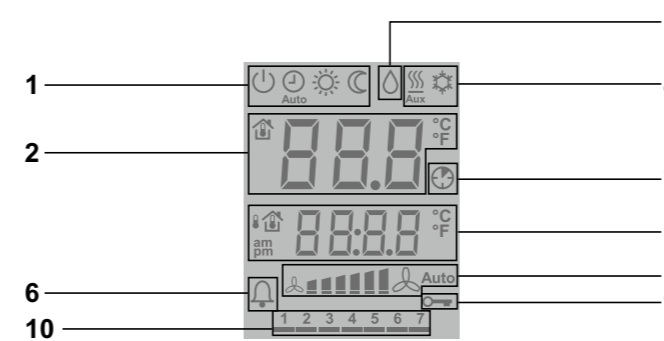

- 1 Operating mode
  - ⏻ Protection
  - ☀️ Comfort
  - 🌙 Economy
  - 🕒 Auto Timer according to schedule (via bus)

- 2 Displays room temperature, setpoints and control parameters.
  - 🌡️ Symbol indicates current room temperature

- 3 Fan mode
  - 🌀 Auto Auto fan active
  - 🌀 Fan speed: low, medium, high

- 4 Heating / cooling mode
  - ❄️ Cooling
  - 🔥 Heating
  - 🔥 Aux Electric heater active

- 5 💧 Condensation in room (dew point sensor active)

- 6 🔔 Indicates fault or reminder

- 7 🕒 Temporary Comfort mode extension active

- 8 Additional user information, like outside temperature 🌡️ or time of day from KNX bus. Selectable via parameters

- 9 🔒 Button lock active

- 10 1 2 3 4 5 6 7 Weekday 1...7 from KNX bus (1 = Monday / 7 = Sunday)

#### DISPOSAL

The device is classified as waste electronic equipment in terms of the European Directive 2002/96/EC (WEEE) and should not be disposed of as unsorted municipal waste.

The relevant national legal rules must be adhered to. Regarding disposal, use the systems setup for collecting electronic waste.

Observe all local and applicable laws.

# Supported KNX tools

## ETS PROFESSIONAL

### ETS PROFESSIONAL

ETS Professional is an engineering tool. It is used to set up the communication of the thermostat and assigns the communication object to group addresses (S-mode).

All other parameters are only used for choosing (making visible / hiding) the communication objects!

This Manual does not describe how to operate ETS Professional and commission a device. Refer to the KNX Manual for more details.

**NOTE:**  
Setting RDF KNX parameters is only supported by ETSf or higher.

### Parameter settings in ETS Professional

For setting the parameters, open the project and select a device. To start the parameter settings, select **Edit**, then **Edit parameters**.

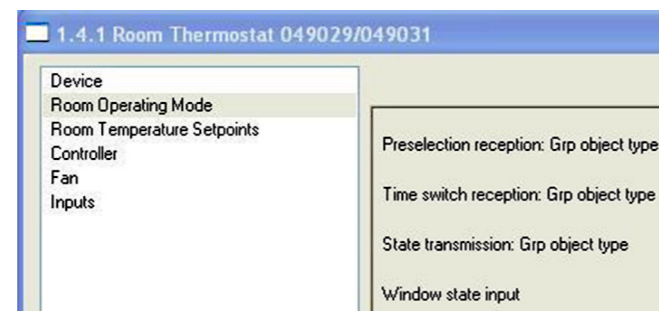

**NOTE:**  
The tool required is ETS Professional version 3f or higher!

# Connection

## CONNECTION TERMINALS

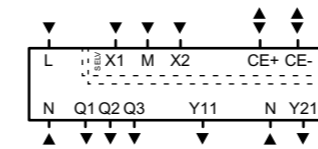

- L, N** Operating voltage AC 230 V
- Q1** Control output "Fan speed 1 AC 230 V"
- Q2** Control output "Fan speed 2 AC 230 V"
- Q3** Control output "Fan speed 3 AC 230 V"
- Y11, Y21** Control output "Valve" AC 230 V (NO, for normally closed valves), output for compressor or output for electric heater
- X1, X2** Multifunctional inputs for temperature sensor or potential-free switch  
Factory setting:  
- X1 = Operating mode switchover contact  
- X2 = External sensor  
(function can be selected via parameters P38 / P40).
- M** Measuring neutral for sensor and switch
- CE+** KNX data +
- CE-** KNX data -

## CONNECTION DIAGRAMS

### Application

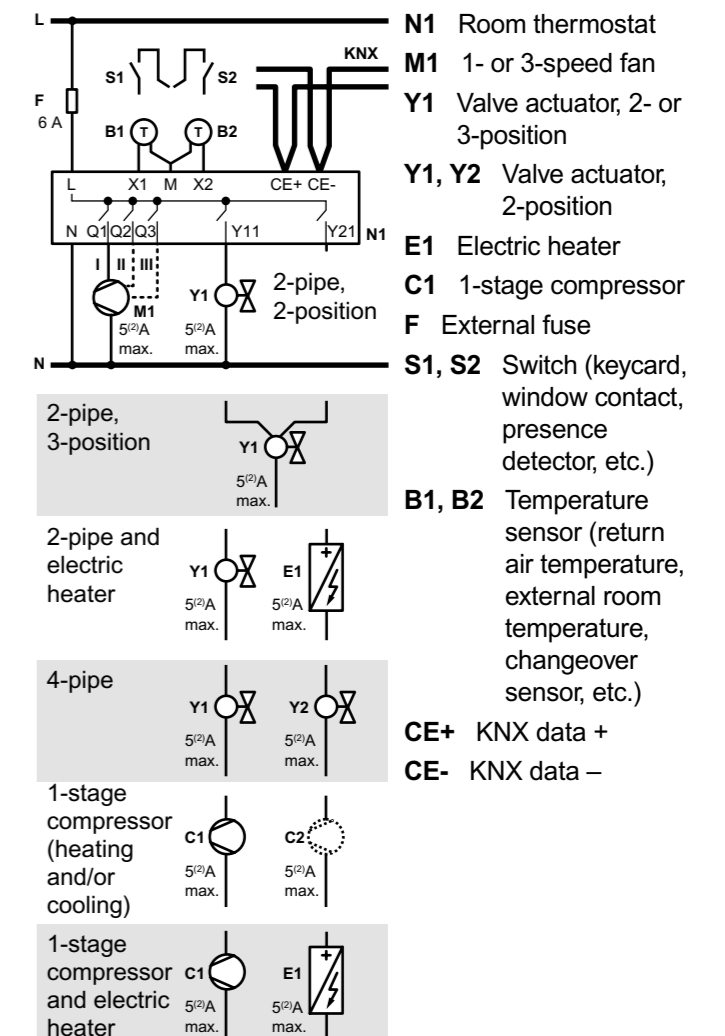

# Mechanical design

## GENERAL

The thermostats consist of 2 parts:

- Front panel with electronics, operating elements and built-in room temperature sensor.
- Mounting base with power electronics. The rear of the mounting base carries the screw terminals.

The base fits on a rectangular conduit box with 60.3 mm fixing centers.

Slide the front panel in the mounting base and snap on.

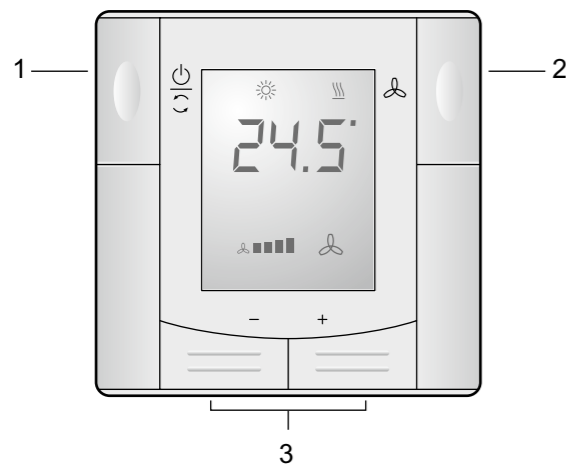

- 1 Operating mode selector
- 2 Button for fan operation
- 3 Buttons to adjust setpoints and control parameters. For operation, refer to page 62

## DIMENSIONS

Dimensions in mm

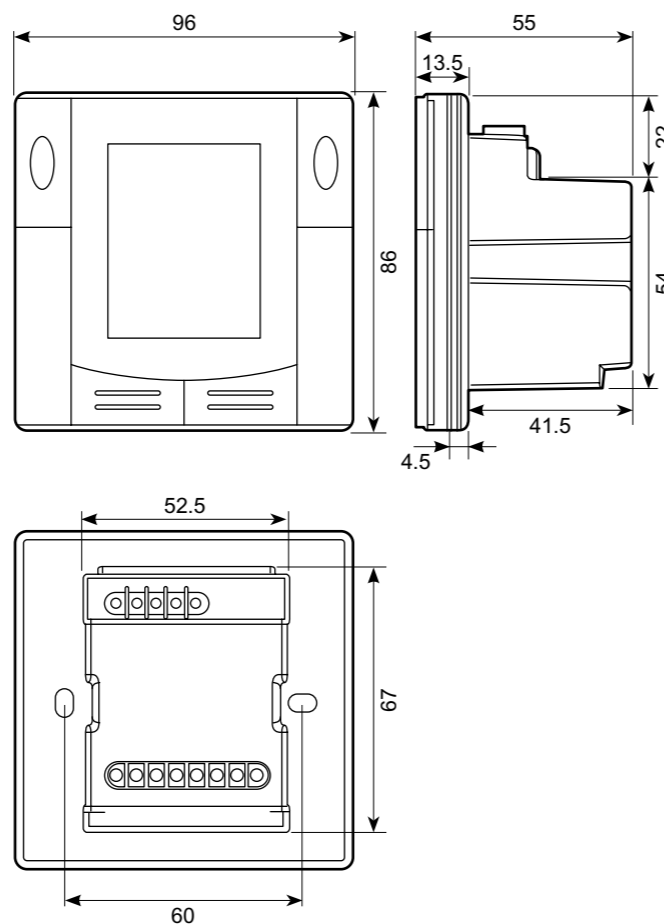

# Technical data

## POWER SUPPLY

Operating voltage: AC 230 V +10/-15%  
 Rated voltage: AC 230 V  
 Frequency: 50/60 Hz  
 Power consumption: Max. 4 VA / 3.4 W

## OUTPUTS

Fan control Q1, Q2, Q3-N: AC 230 V  
 Rating: Max. 5(2) A  
 Control output Y11-N / Y21-N (NO) : AC 230 V  
 Rating: Max. 5(2) A  
 Maximum current (Qx+yxx): Max. 6 A

## INPUTS

### Multifunctional input X1-M/X2-M

Temperature sensor input:  
 Type : NTC  
 Temperature range: 0...49 °C  
 Cable length: Max. 80 m

Digital input:  
 Operating action  
 Contact sensing: Selectable (NO/NC)  
 Insulation against mains voltage (SELV):  
 SELV 0...5 V/max. 5 mA  
 4 kV, reinforced insulation  
 Parallel connection of several thermostats for one switch: max. 20 thermostats par commutateur

### Function of inputs (Selectable)

External temperature sensor, heating / cooling changeover sensor, operating mode switchover contact, dew point monitor contact, enable electric heater contact, fault contact, monitoring input:  
 X1 : P38  
 X2 : P40

## KNX BUS

Interface type: KNX, TP1-64  
 (electrically isolated)  
 Bus current: 20 mA

## OPERATIONAL DATA

### Switching differential (adjustable)

Heating mode (P30): 2 K (0.5...6 K)  
 Cooling mode (P31): 1 K (0.5...6 K)

### Setpoint setting and range

☀ Comfort (P08): 21 °C (5...40 °C)  
 ☁ Economy (P11-P12): 15 °C/30 °C (OFF, 5...40 °C)  
 ☹ Protection (P65-P66): 8 °C/OFF (OFF, 5...40 °C)

### Multifunctional input X1/X2 (Selectable 0...8)

Input X1 default value (P38): 3 (operating mode switchover)  
 Input X2 default value (P40): 1 (external temperature sensor)

### Built-in room temperature sensor

Measuring range: 0 ...49 °C  
 Accuracy at 25 °C (after calibration via P05): < ± 0.5 K  
 Temperature calibration range: ± 3.0 K

### Settings and display resolution

Setpoints: 0.5 °C  
 Current temperature value displayed: 0.5 °C

## Technical data (continued)

### ENVIRONMENTAL CONDITIONS

#### Operation: IEC 721-3-3

Climatic conditions: Class 3K5  
 Temperature: 0...50 °C  
 Humidity: <95 % r.h.

#### Transport: IEC 721-3-2

Climatic conditions: Class 2K3  
 Temperature: -25...60 °C  
 Humidity: <95 % r.h.  
 Mechanical conditions: Class 2M2

#### Stockage

Climatic conditions: Class 1K3  
 Temperature: -25...60 °C  
 Humidity: <95 % r.h.

### STANDARDS AND DIRECTIVES

#### CE conformity

EMC directive: 2004/108/CE  
 Low-voltage directive: 2006/95/CE

#### C-tick conformity to EMC emission standard

AS/NZS 61000.6.3: 2007



#### Product standards

Automatic electric controls for household and similar use: EN 60730-1  
 Special requirements for temperature-dependent controls: EN 60730-2-9  
 Electronic control type: 2.B (micro-disconnection on operation)  
 Home and Building Electronic Systems: EN 50090-2-2

### Electromagnetic compatibility

Emissions: IEC/EN 61000-6-3  
 Immunity: IEC/EN 61000-6-2

### Safety class: II as per EN 60730

### Pollution class: Normal

### Degree of protection of housing: IP30 as per EN 60529

### GENERAL

#### Connection terminals

Solid wires or prepared stranded wires 1 x 1,5 mm<sup>2</sup>

#### Housing front color

RAL 9003 white

#### Weight without / with packaging

0.246 kg / 0.316 kg

## Index

<b>1</b>	<b>D</b>
1-speed fan.....35	Dew point monitoring.....22, 40
	Disposal.....63
<b>3</b>	<b>E</b>
3-position control signal.....32	Effect of Protection via time schedule ..... 12
3-speed fan.....35	Electric heater .....28
<b>A</b>	Enable / disable electric heater .....29, 35
Applications overview ..... 18	Expert level parameters.....54
Auto Timer mode ..... 12	Extension of Comfort mode ..... 13
Automatic heating / cooling changeover.....19, 21	External / return air temperature .....35
Automatic heating / cooling changeover via bus ..... 19	External / return air temperature sensor..... 19
<b>B</b>	<b>F</b>
Basic application .....29	Fan in Auto Timer mode .....36
Button lock.....22	Fan kick function.....36
<b>C</b>	Fan minimum on-time.....36
Changeover switch ..... 19	Fan operation as per heating / cooling mode, or disabled .....38
Chilled / heated ceiling applications .....29	Fan operation in dead zone.....38
Clean fan filter reminder .....36	Fan overrun .....36
Compressor applications.....18, 29	Fan start .....39
Control outputs configuration.....33	Fault.....42
Control outputs overview .....32	Fault on KNX .....42
Control parameters.....45	Fault, handling .....42
Control sequences.....21	Floor cooling .....20
Cooling demand .....43	Floor heating.....20
Cooling sequence.....21	Floor temperature limitation function .....21

## Index (continued)

<b>H</b>		<b>P</b>	
Heating / cooling changeover .....	19, 40	PWM.....	32
Heating and cooling sequence .....	21	<b>R</b>	
Heating demand .....	43	Radiator applications.....	29
Heating sequence .....	21	Remote heating / cooling changeover .....	54
<b>I</b>		Reset parameters .....	52
Integral action time .....	54	<b>S</b>	
<b>M</b>		Sensor input .....	40
Main and secondary .....	30	Setpoint Comfort mode .....	33
Manual heating / cooling changeover.....	20	Setpoint Economy mode .....	33
Manually select heating or cooling sequence.....	21	Setpoint limitation .....	15
Minimum output.....	20	Setpoint Protection mode .....	34
Moisture.....	20	Setpoints and sequences .....	34
Mounting and installation.....	59	Standby / Protection mode .....	9
Multifunctional inputs .....	40	Switching differential .....	10
<b>O</b>		Synchronization.....	32
ON/OFF control signal.....	32	<b>T</b>	
Operating mode		Temperature out of range.....	42
Priority intervention.....	8	Temporary setpoint.....	15
Operating mode button.....	62	Time schedule change mode .....	62
Operating mode switchover .....	8	<b>U</b>	
<b>P</b>		Universal applications.....	18
Parameter setting .....	51	<b>W</b>	
Precomfort.....	13	Window contact.....	11
Proportional band.....	27, 37	Window state .....	10, 11, 40
Protection mode / Standby .....	9		
Purge function .....	20		



**Siège social :**

128, av. du Maréchal-de-Lattre-de-Tassigny  
87045 Limoges Cedex - France

tél : 05 55 06 87 87

fax : 05 55 06 88 88

[www.legrand.com](http://www.legrand.com)