



## Scenario control

5739 02

5739 03

### Description

The Scenario Control is a device which lets you call, create or edit scenarios saved in an Scenario Module Q35 51, simply and intuitively.

### Technical data

Power supply from SCS BUS: 18 – 27 Vdc

Consumption : 9 mA

### Dimensional data

Size: 2 flush-mounting modules

Depth: 15.5 mm

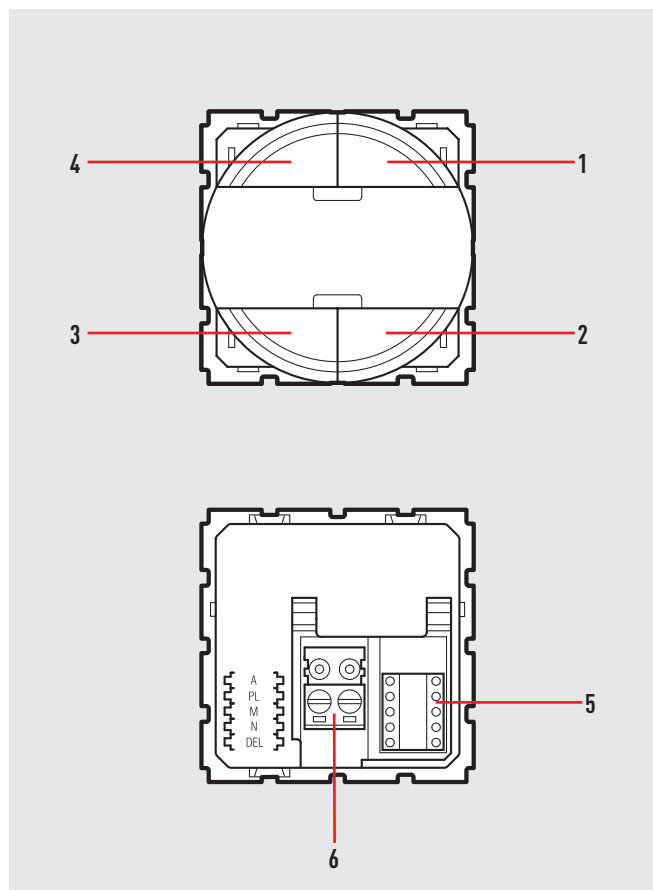

### Legend

1. Key 2
2. Key 4
3. Key 3
4. Key 1
5. Configurator housing
6. BUS

## Configuration

Positions A and PL of the scenario control must correspond to those in the scenario module 035 51. The association of each key of the control with one of the scenarios stored by the module is made by configuring housing M. It is possible to configure positions N and DEL to set the number of the scenario to be activated with a delay (15 s – 15 ms).

### Correspondence between the 4 keys of the scenario control and the number of scenarios stored in the scenario module:

Configurator M	Key 1	Key 2	Key 3	Key 4
1	Scenario 1	Scenario 2	Scenario 3	Scenario 4
2	Scenario 5	Scenario 6	Scenario 7	Scenario 8
3	Scenario 9	Scenario 10	Scenario 11	Scenario 12
4	Scenario 13	Scenario 14	Scenario 15	Scenario 16

Depending on the configurators inserted in position N, it is possible to set a delay to be associated with one or all scenarios before being actually actuated.

Configurator N	Key 1	Key 2	Key 3	Key 4
0	None	None	None	None
1	Delay ON	None	None	None
2	None	Delay ON	None	None
3	None	None	Delay ON	None
4	None	None	None	Delay ON
5	Delay ON	Delay ON	Delay ON	Delay ON

The configurator in the DEL position determines the delay on activating the scenario.

Configurator DEL	Delay
0	None
1	1 minute
2	2 minutes
3	3 minutes
4	4 minutes
5	5 minutes
6	10 minutes
7	15 minutes
8	15 seconds
9	30 seconds

## Scenario programming

To program, change or delete a scenario, the programming of Scenario Module 035 51 must be enabled, confirmed by the programming status LED turning green (press the lock/unlock key for at least 0.5 seconds). After this has been done proceed as follows:

- 1) press one of the four control keys the scenario should be associated to for 4 seconds. The corresponding LED starts flashing;
- 2) set the scenario using the corresponding controls for the various Automation, Temperature control, Sound system, etc. functions;
- 3) confirm the scenario by quickly pressing the corresponding key on the control to exit programming mode;
- 4) to change a scenario or create new ones to combine with other pushbuttons, repeat the procedure starting from 1.

To recall an existing scenario, a quick pressure of the corresponding key is enough.

To delete a scenario, proceed as follows:

- 1) the scenario module must be enabled for programming
- 2) press the pushbutton of the scenario to delete for at least 10 seconds. The corresponding LED will flash quickly for about 2 seconds, confirming that the scenario has been deleted. If the LED does not flash, the procedure has been unsuccessful

To reset the whole memory from the scenario module press the DEL key for 10 seconds. The yellow LED, "reset scenarios", will flash quickly.

**NOTE:** Once the necessary operations have been completed, block programming by pressing the lock/unlock key of the scenario module for at least 0.5 seconds, until the corresponding LED turns red.

**Controls for the 035 65 scenario programmer:** pressing a key while configuring M=CEN, N=0 and DEL=0 will send to the programmer an A/PL control as well as the pushbutton number corresponding to the key pressed.