

## 2 P+E socket outlets - German standard IP 55 - IK 08

### VEHICLE MANUFACTURER DETAILS

### INSTALLER DETAILS

MODE 2

100% electric vehicles  
 Rechargeable hybrid vehicles  
 Extended-range electric vehicles



MODE 1

Scooters, quad bikes and light vehicles up to 8 A



Occasional charging possible on conventional socket

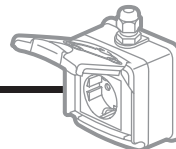

Legrand Green'up Access secure socket for day-to-day charging of electric vehicles

2.5 mm<sup>2</sup>

Dedicated line with 30 mA, type F (HPI), 16 A single phase RCBO  
 The earth measurement must be checked\*



Charging time cut by at least 30% with the Green'Up Access socket\*\*



\*To be carried out by a professional electrician.

\*\*Charging time varies according to vehicle model.

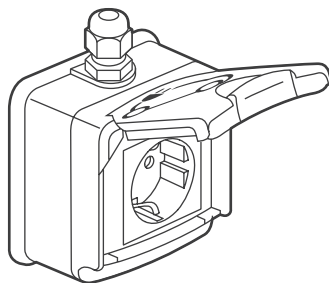

0 904 72

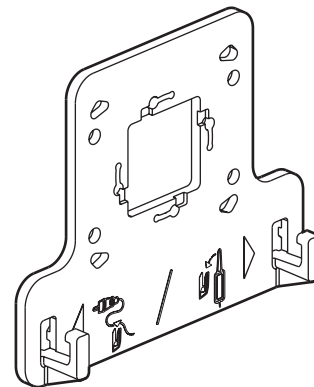

0 904 78

### 1. USE

3.7 kW, modes 1 and 2, 2 P+E, 16 A, 230 V, German standard socket outlet with safety shutters.

- For safe charging of electric vehicles supplied in modes 1 and 2 (charging on a domestic socket).
- Cost-effective, safe 2 P+E socket certified for all electric vehicles (mode 1 and mode 2). Equipped with optimised connection terminals, metal contacts with silver surface treatment (5 µm). Equipped with **Green'up System**, a Legrand technology.
- **Patented Green'up System**: the EV detects the secure **Green'up Access** infrastructure and selects the maximum power that can be supplied via the socket (reduced charging time).
- Suitable for private houses and workplaces.
- It is connected from the electrical panel via a dedicated line (1 line per socket) with protection via a 30 mA - 16 A type F (HPI) RCBO. Bus cable Cat. No. 0 492 31 can be used as an option to migrate to the Green'Up Premium communication terminal (full mode 3 ready).

### 2. RANGE

Description	Cat. No.
2 P+E socket outlet - surface mounted Equipped with an ISO 20 cable gland on the socket outlet and an ISO 20 plug which is not fitted. Supplied with bracket Cat. No. 0 904 78.	0 904 72
Bracket with hooks For suspending the charging cable control box.	0 904 78

## 2 P+E socket outlets - German standard IP 55 - IK 08

### 3. POSITIONING

#### ■ 3.1 Fixing

The box is fixed onto the support frame using 2 (or 4) Ø 4 to 4.5 mm screws IP 55 weatherproof fixing for all surfaces.

ISO 20 - 1000 R02V cable  
Rigid or identical flexible type

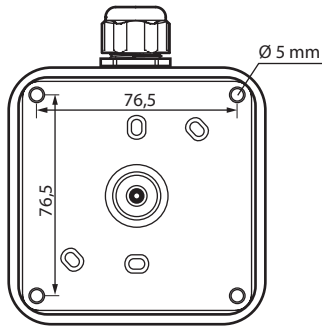

#### ■ 3.2 Assembly

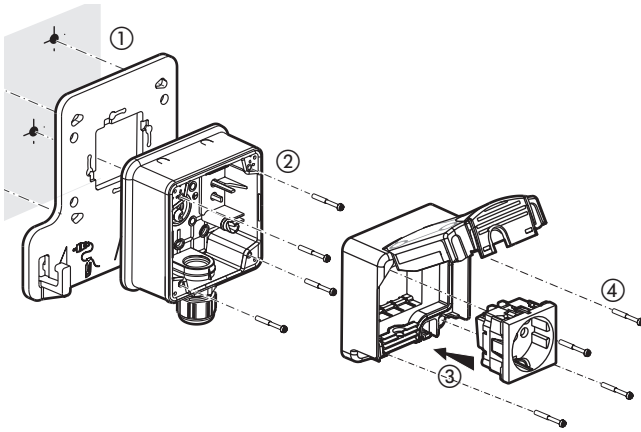

The front part (mechanism cover) is attached to the box using 4 coarse pitch screws.  
(Min. tightening torque for IP 55: 0.5 Nm).

#### ■ 3.3 Installation recommendation

##### MODE 1

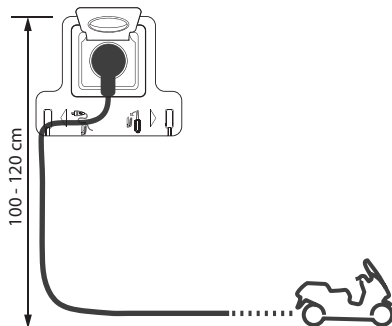

### 3. POSITIONING (continued)

#### ■ 3.3 Installation recommendation

##### MODE 2

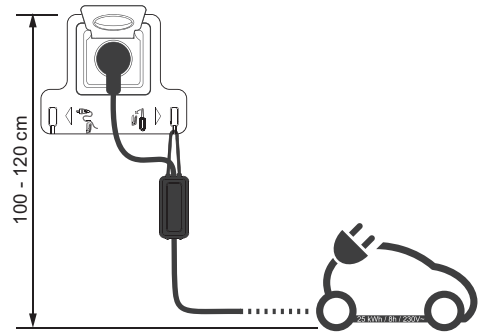

### 4. OVERALL DIMENSIONS (mm)

0 904 72

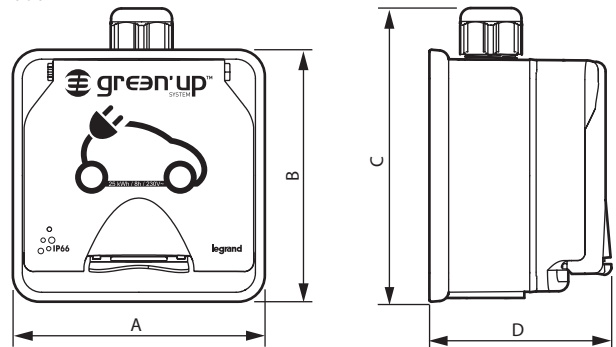

0 904 78

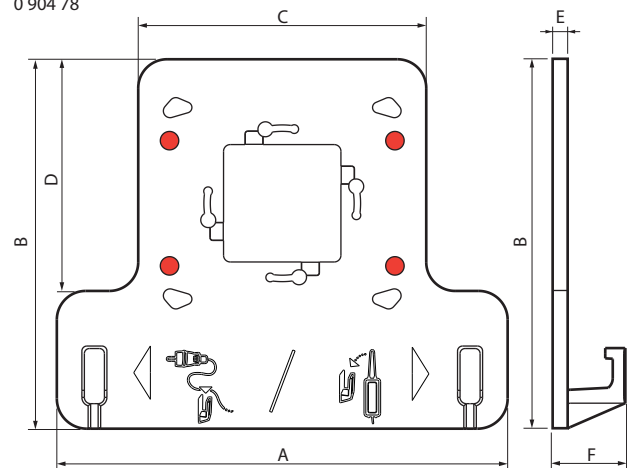

Cat. Nos	A	B	C	D	E	F
0 904 73	98	98	117	70	-	-
0 904 78	180	147.5	115	92.5	6	28

## 2 P+E socket outlets - German standard IP 55 - IK 08

### 5. CONNECTION

Pillar terminals supplied open, with screws locked in unscrewed position  
 Min. capacity: 1 x 1.5 mm<sup>2</sup>  
 Max. capacity: 1 x 6 mm<sup>2</sup> rigid or equivalent  
 Min. tightening torque: 0.8 Nm  
 Screwdriver: Flat, 3.5 to 5 mm  
 Phillips No. 1

#### ■ Installation wiring diagram

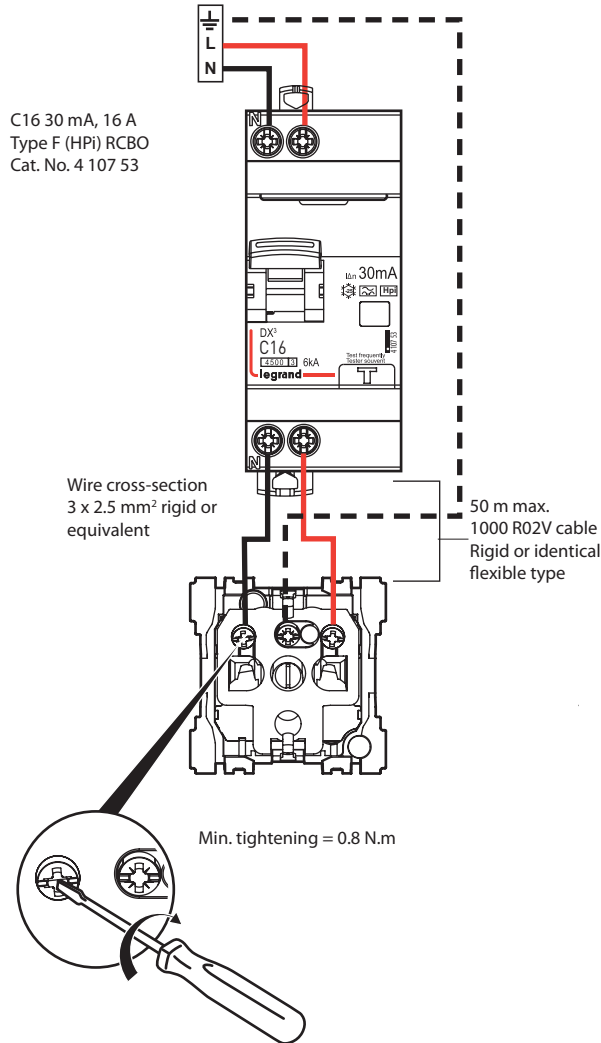

### 6. TECHNICAL FEATURES

#### ■ 6.1 Mechanical features

Impact test: IK 08  
 Penetration by solid/liquid matter: IP 55

#### ■ 6.2 Materials

- Box and cover: glass fibre reinforced polypropylene, colour light grey T029  
 - Mechanism: polycarbonate, colour grey RAL 7016  
 - Cover fixing screws: stainless steel  
 - Seal: SEBS elastomer, colour green (anise)

#### UV resistance:

No noticeable change in appearance following 7-day test with ≈ 550 W/m<sup>2</sup> lighting.

(Colorimetric measurement according to laboratory).

Withstands products which are: - Chlorinated, pH 10-11  
 - Alkaline, pH 9-10  
 - Acid, pH 3

Salt spray resistance: 7 days (168 h)

Halogen-free

#### Self-extinguishing:

850°C/30 s for insulating components holding live parts in place.  
 650°C for other insulating components.

#### ■ 6.3 Climate features

Storage and usage temperatures: - 20°C to + 40°C

#### ■ 6.4 Electrical features

Voltage: 230 V~

Power: 3.7 kW

Current: 16 A

Frequency: 50/60 Hz

Charging all electric vehicles equipped with a mode 1 or mode 2 cable, and with batteries up to 25 kW/h capacity.

#### Please note:

Your installer will advise you on the most suitable electricity supply tariffs for charging your vehicle.

Always unplug the socket before starting the vehicle.

Only the cables supplied with the vehicle are authorised for use with the EV sockets.

Use of extension cables or adapters is prohibited.

The EVSE box must be suspended.

Use of a voltage surge protector is recommended.

### 7. MAINTENANCE

Withstands high-pressure cleaning at 70 to 90 bar, at 70 to 80°C.

Surface cleaning with a dry cloth or cloth moistened with soapy water.

Do not use acetone, tar-removing cleaning agents or trichloroethylene.

### 8. ACCESSORIES

#### ■ 8.3 Bracket Cat. No. 0 904 78

Bracket with hooks

For suspending the charging cable control box.

#### ■ 8.4 ISO 20 cable gland Cat. No. 0 980 03

Spare part.

### 9. STANDARDS AND APPROVALS

Conforms to standards IEC 60884-1 and DIN 49440-1.

Conforms to the LCIE test programme for qualification of EV reinforced sockets: 125 8-hour charge-discharge cycles at 16 A at 230 V~.