

# USER MANUAL



## POWER FACTOR CORRECTION

### Power Quality Controller PQC

# Contents

---

2

<b>1</b>	<b><u>SAFETY</u></b>	<b>7</b>
1.1	OBJECTIVE	7
1.2	SAFETY INSTRUCTIONS	7
1.3	INTENDED USE	8
1.4	IMPROPER USE	8
1.5	REPAIR	9
1.6	SYMBOLS USED	9
<b>2</b>	<b><u>TECHNICAL DATA</u></b>	<b>10</b>
<b>3</b>	<b><u>INSTRUMENT DESCRIPTION</u></b>	<b>14</b>
3.1	FUNCTION	14
3.2	REGENERATION	14
<b>4</b>	<b><u>MOUNTING THE INSTRUMENT</u></b>	<b>15</b>
4.1	SUITABLE LOCATION	15
4.2	INSTALLING THE INSTRUMENT	15
<b>5</b>	<b><u>INSTALLATION</u></b>	<b>17</b>
5.1	ELECTRICAL CONNECTIONS	17
5.2	EARTH CONNECTION	18
5.3	SUPPLY VOLTAGE	19
5.4	VOLTAGE MEASUREMENT	20
5.5	CURRENT MEASUREMENT	21
5.6	OUTPUT RELAYS (CONTROL OUTPUTS)	23
5.7	CONNECTION DIAGRAMS OF ALL PQC INSTRUMENT TYPES	24
5.7.1	CONNECTION DIAGRAM: VERSION PQC 1202401-XX	24
5.7.2	CONNECTION DIAGRAM: VERSION PQC 1202403-XX	25
5.7.3	CONNECTION DIAGRAM: VERSION PQC 0602401-XX	26
5.7.4	CONNECTION DIAGRAM: VERSION PQC 1204801-XX	27
5.7.5	CONNECTION DIAGRAM: VERSION PQC 1204803-XX	28
5.7.6	CONNECTION DIAGRAM: VERSION PQC 0614801-XX	29

5.7.7	OPTIONS FOR CONNECTING THE AUX POWER SUPPLY FOR PQC XXX480X-XX VERSIONS	30
-------	---	----

## **6 COMMISSIONING (INITIAL START-UP)** **31**

---

6.1	ALARM FUNCTION	31
6.1.1	LIST OF ALARMS AND MESSAGES	31
6.2	SAFETY PRECAUTIONS BEFORE START-UP	32
6.3	FUNCTIONAL CHECKOUT	32
6.4	CONFIGURATION	32
6.5	AUTOMATIC COMMISSIONING	32
6.5.1	AUTOMATIC CONNECTION IDENTIFICATION	33
6.5.2	AUTOMATIC IDENTIFICATION OF THE CONNECTED CAPACITOR STAGES	33
6.5.3	CALCULATION OF C/K	34

## **7 DESCRIPTION OF THE MENU** **35**

---

7.1	MENU OVERVIEW	36
-----	---------------	----

## **8 MAIN MENU** **38**

---

8.1	PQC INITIAL START-UP	39
8.1.1	LANGUAGE SELECTION ON START-UP	39
8.1.2	START-UP	41
8.2	PQC OVERVIEW	41
8.2.1	DISPLAYED PARAMETERS	42
8.3	CONTROL DIAGRAM	44
8.3.1	SCALE	44
8.4	MANUAL CONTROL	45
8.4.1	STAGES MENU	46
8.5	SETTINGS	47
8.5.1	SETTABLE CONTROL PROFILES	47
8.5.2	TYPICAL CONTROL PROFILE APPLICATIONS	47
8.5.3	GENERAL SETTINGS	54
8.6	INFO / STATUS	60
8.6.1	PQC STATUS	61
8.6.2	CORRECTIVE POWER	61
8.6.3	CAPACITOR STAGES TABLE	62
8.6.4	CAPACITOR STAGES RATING DIAGRAM	62
8.6.5	SWITCH CYCLE DIAGRAM	62
8.6.6	VOLTAGE AND CURRENT HARMONICS DIAGRAM	63

8.6.7	VOLTAGE AND CURRENT HARMONICS TABLE	63
8.6.8	MANUAL FREQUENCY ANALYSIS	64
8.7	ABOUT PQC SUBMENU	65
8.8	FACTORY DEFAULT SETTINGS	65
8.9	UPDATE	69
<b>9</b>	<b><u>INSTRUMENT VERSIONS</u></b>	<b>70</b>
<b>10</b>	<b><u>MAINTENANCE</u></b>	<b>72</b>
10.1	CLEANING	72
<b>11</b>	<b><u>DECOMMISSIONING AND REMOVAL, STORAGE AND DISPOSAL</u></b>	<b>73</b>
11.1	DECOMMISSIONING AND REMOVAL	73
11.2	STORAGE	74
11.3	DISPOSAL	75
<b>12</b>	<b><u>GENERAL OPERATION</u></b>	<b>76</b>
12.1	TROUBLESHOOTING	76
<b>13</b>	<b><u>SCOPE OF SUPPLY</u></b>	<b>78</b>

## Figures

---

Figure 1	PQC dimensions in mm.....	15
Figure 2	Connection diagram for PQC 1202401-XX.....	24
Figure 3	Connection diagram for PQC 1202403-XX.....	25
Figure 4	Connection diagram for PQC 0602401-XX.....	26
Figure 5	Connection diagram for PQC 1204801-XX.....	27
Figure 6	Connection diagram for PQC 1204803-XX.....	28
Figure 7	Connection diagram for PQC 0614801-XX.....	29
Figure 8	Part of the connection diagram for 400/415 V networks with no neutral conductor	30
Figure 9	Part of the connection diagram for 690 V networks with a neutral conductor .....	30
Figure 10	PQC Start screen (firmware version number may be different).....	32
Figure 11	Menu structure 1.....	36
Figure 12	Menu structure 2.....	37
Figure 13	Menu structure 3.....	37
Figure 14	Main menu 1/3 .....	38
Figure 15	Main menu 2/3 .....	38
Figure 16	Main menu 3/3 .....	38
Figure 17	Changing the working language.....	39
Figure 18	Identification: Stage + Connection.....	40

Figure 19	Identification: Connection.....	40
Figure 20	Identification: Connection submenu .....	40
Figure 21	Identification: Stage .....	40
Figure 22	Identification: Stage submenu.....	40
Figure 23	Identification: Manual.....	40
Figure 24	Identification: Manual submenu.....	40
Figure 25	Connection identification started .....	41
Figure 26	Capacitor stage identification started.....	41
Figure 27	Start-up completed .....	41
Figure 28	PQC overview L1 (1-phase).....	42
Figure 29	PQC overview L1 (3-phase).....	42
Figure 30	Capacitor stage statuses (1-phase, 6 stages).....	42
Figure 31	Capacitor stage statuses (3-phase, 12 stages).....	42
Figure 32	Control diagram.....	44
Figure 33	Control diagram with additional information.....	44
Figure 34	Zoomed in on control diagram .....	44
Figure 35	Manual control .....	45
Figure 36	Manual control enabled.....	45
Figure 37	Manual control: Switch out stages .....	45
Figure 38	Manual control: Stages menu.....	46
Figure 39	Example of a selected stage .....	46
Figure 40	Message on failed attempt to switch in a stage .....	47
Figure 41	Settings.....	47
Figure 42	Control profiles .....	49
Figure 43	Control profile parameters .....	49
Figure 44	Control response after setting target $\cos \varphi = 1$ , limitation = 0, parallel shift = 0	50
Figure 45	Control response after setting target $\cos \varphi = 0.92$ , limitation = 0, parallel shift = 0	50
Figure 46	Control response after setting target $\cos \varphi = 1$ , limitation = 0, parallel shift = +1.0	51
Figure 47	Control response after setting target $\cos \varphi = 0.92$ ind, limitation = OFF, parallel shift = -1.0	51
Figure 48	Control response after setting target $\cos \varphi = 0.92$ ind, limitation = +1.0 .....	52
Figure 49	Control response after setting target $\cos \varphi = 0.92$ ind, limitation = +1.0, parallel shift = -1.0	52
Figure 50	Control response after setting target $\cos \varphi = 0.95$ cap, limitation = -1.0, parallel shift = 0	53
Figure 51	Phase L1 is the control phase .....	53
Figure 52	General settings menu .....	54
Figure 53	Capacitor stages.....	55
Figure 54	Set limits 1/2.....	56
Figure 55	Set limits 2/2.....	56
Figure 56	Change set limit for switching cycle counter .....	56
Figure 57	Alarm management .....	57
Figure 58	Alarm management; here the Display alarm option.....	57
Figure 59	Extensions menu .....	58
Figure 60	Modbus configuration .....	58
Figure 61	Factory default settings .....	59
Figure 62	Password prompt.....	60
Figure 63	Info / status 1/3.....	60
Figure 64	Info / status 2/3 .....	60

Figure 65	Info / status 3/3 .....	60
Figure 66	PQC status overview .....	61
Figure 67	Total corrective power Q.....	61
Figure 68	Capacitor stages table.....	62
Figure 69	Diagram showing all stages at 100% .....	62
Figure 70	Diagram showing corrective power of all stages .....	62
Figure 71	Switch cycle diagram .....	62
Figure 72	Current harmonics diagram, y-axis 100%.....	63
Figure 73	Current harmonics zoomed in, y-axis 25% .....	63
Figure 74	Voltage harmonics table.....	63
Figure 75	Manual frequency analysis.....	64
Figure 76	About PQC .....	65

## Tables

---

Table 1	Connection types for current transformers in L1, L2 and L3.....	33
Table 2	c/k settings at 400 V AC and 50 Hz.....	34
Table 3	Key functions .....	35
Table 4	Factory default settings .....	62
<a href="#">Table 5</a>	<a href="#">Instrument versions</a> .....	<a href="#">67</a>

## Formulas

---

Formula 1	Calculation of c/k .....	34
-----------	--------------------------	----

# 1 Safety

## 1.1 OBJECTIVE

This operating manual has been prepared for persons who install, connect, commission and operate the PQC Power Quality Controller.

## 1.2 SAFETY INSTRUCTIONS



**No claims under guarantee shall be valid in the event of damages caused by failure to observe the instructions in this operating manual. We shall not be held liable for consequential damages!**

**Incorrect operation or failure to observe the safety instructions will invalidate all claims under the guarantee, and no liability is accepted for any injuries to persons or damages to assets arising therefrom or occasioned thereby!**



### **DANGER!**

The following instructions must be observed to prevent danger to life and limb or damage to equipment and other assets:

- Installation and commissioning of the instrument in industrial plant must be carried out in strict compliance with the standards IEC 61508 and DIN VDE 0801.
- Any other laws, standards, regulations and safety rules (IEC, EN, VDE, etc.) relevant to this product and the protection of persons and assets must be observed. In Germany, it is essential to comply with the Equipment Safety Act (GSG) and the regulations of the German Social Accident Insurance Institutions. In other countries, the equivalent local regulations must be followed.
- Installation, commissioning, modifications and retrofitting may only be carried out by appropriately qualified personnel.
- In Germany, it is essential to comply with the regulations of the Social Accident Insurance Institution covering electrical installations. In other countries, the equivalent local regulations must be followed.
- The instrument contains live components at the AC supply voltage and must therefore not be opened.
- If the instrument is visibly damaged, it must not be installed, connected or commissioned.
- Only approved installation cables must be used.
- If the instrument does not work after commissioning, it must again be isolated from the power supply.
- The instrument must only be employed on duties up to the specified maximum power. Overloading the instrument can result in its destruction, create a fire hazard or cause an electrical accident. The load ratings for the various connections must not be exceeded.
- Do not expose the instrument to direct sunlight or high temperatures, as these could damage it or shorten its service life.
- Do not install the instrument near to sources of heat such as radiators or other devices that generate heat.

- Do not expose the instrument to rain, water, dampness or high levels of humidity. Avoid direct contact with water at all cost.
- Failure to observe the safety instructions can result in death, serious injury or severe damage to equipment and other assets.
- In commercial premises, the local accident prevention regulations must be complied with (e.g. in Germany, the regulations of the German Social Accident Insurance Institutions for electrical installations and equipment).
- The safety of the system in which the PQC is incorporated is the responsibility of the persons installing and operating the system.
- For safety reasons and to retain conformity with product approval requirements (CE marking), the user is not permitted to convert or otherwise modify the instrument.
- The instrument must always be handled with due care; if it is jolted, knocked or dropped from even a low height, it will be damaged.
- This operating manual may be changed without notification. Please consult our website [www.schrack.com](http://www.schrack.com) for the up-to-date version.

When work is carried out on the instrument terminals and connecting cables, there is a risk of live components being touched inadvertently. The working voltage may present a hazard to health or may even be life-threatening.

The risk to life and limb can be significantly reduced by observing the above safety precautions.

- The user must ensure that all operators are familiarized with this operating manual and follow it at all times.
- This operating manual must be read through carefully and completely before the instrument is installed, connected, commissioned and operated. All actions taken must be in accordance with this operating manual.
- The operating manual must be held for future reference.
-  Wherever this symbol is shown, the documentation must be referred to.

### 1.3 INTENDED USE

The PQC Power Quality Controller is intended for the following applications within the scope of the technical data (see Section 2, Technical data):

- Control of reactive power in stages. Output relays (switched outputs, stages) are provided for this purpose. Capacitors can be connected to these via current-amplifying electromechanical devices (relays, contactors).
- Measurement of data relevant to network power quality, such as voltage, current and frequency, either in any desired phase 'L1' or in all three phases L1, L2 and L3, depending on the instrument version (see Section 2, Technical data); connection of an alarm contact rated within the allowable limits for the electrical parameters (see Section 2, Technical data)

The PQC is intended for installation in stationary, weather-protected control cabinets and enclosures located indoors. Exposure to dampness is not permitted. The instrument is installed vertically, usually on the outside of the control cabinet or enclosure, so that the controls and display are accessible to the operator.

The USB port is a service interface provided solely for updating the PQC firmware. Users are not permitted to use this USB port for any other purpose, and therefore must not connect any cable or device to it. When the PQC is in operation, the USB port must not be touched. It is intended for connecting a battery-powered notebook.

### 1.4 IMPROPER USE

Any use of the instrument that deviates from its intended use is considered improper and therefore not permitted. If the PQC is used in a way not specified in this operating manual, the protection supported by the instrument may be adversely affected.



## 1.5 REPAIR

Repairs may not be carried out by the customer or user. Should repair work be necessary, the customer or user must contact Schrack Technik (contact addresses see: [www.schrack.com](http://www.schrack.com)):

## 1.6 SYMBOLS USED

Special instructions in this operating manual are marked by symbols. The corresponding word that expresses the extent of the danger is also printed above the instructions. In order to avoid accidents, death or injury and damage to assets, these instructions must be complied with at all times.

### Warning signs

**DANGER!**

Indicates an immediate danger that if not avoided can result in death or serious injury.

**DANGER!**

Indicates an immediate danger of electric shock that if not avoided can result in death or serious injury.

### Notes for the correct functioning of the instrument

**CAUTION!**

These instructions indicate dangers that could result in damage to equipment if the instructions are not followed.

They can also cover aspects of environmental protection.

**NOTE!**

These instructions, when followed, serve to ensure the correct functioning and fault-free operation of the instrument.

## 2 Technical data

### Power supply

- Supply voltage  
PQC version: PQC xxx240x-xx:  
85–267 V AC (absolute limits), frequency 45–65 Hz or  
100–377 V DC (absolute limits)  
  
PQC version: PQC xxx480x-xx:  
85–530 V AC (absolute limits), frequency 45–65 Hz or  
100–750 V DC (absolute limits)
- Power draw  
maximum 5 VA
- Overcurrent protection  
External, maximum 2 A (slow-blow) specified

### Inputs

- Voltage path measurement inputs  
PQC version: PQC xxxxxx1-xx: single phase  
PQC version: PQC xxxxxx3-xx: 3-phase  
3-phase 80 V AC – maximum 760 V AC (phase–phase,  
absolute limits), this corresponds to 115–690 V AC networks,  
electrically interconnected via high resistance, medium  
voltage measurement via ..1/100 V transformer possible  
  
Power failure detection after duration of a half-wave
- Current path measurement inputs  
PQC version: PQC xxxxxx1-xx: single phase  
PQC version: PQC xxxxxx3-xx: 3-phase  
x/5 A AC or x/1 A AC (transformer secondary current  $\geq 15$   
mA), electrically isolated, power draw maximum 1 VA per  
transformer connection, continuous overload rating up to 6 A  
AC, transient overload maximum 10 A AC for 10 seconds
- Digital inputs and outputs  
PQC version: PQC xxxxxxx-x1:  
  
Up to  $5 \times 5$ –24 V DC inputs, alternatively usable as up to  
 $5 \times 24$  V DC, 100 mA outputs, electrically interconnected with  
each other and the temperature input
- Temperature inputs  
PQC version: PQC xxxxxxx-x1:  
  
 $1 \times$  Pt100 or Pt1000 RTD, 4-wire or 2-wire configuration,  
automatic detector type identification  
 $2 \times$  NTC thermistor type TDK/Epcos-B57861S0502F040,  
type No. 29-20094  
Measurement range -50 – 200 °C  
Electrically connected with the digital outputs

### Outputs

- Output relays (control outputs,  
capacitor stages)  
Normally open with common pole P  
PQC version: PQC 120xxxx-xx: 12 output relays and  
  
PQC version: PQC 060xxxx-xx: 6 output relays,  
  
AC-14 250 V AC, maximum 3 A or DC-13 30 V DC, maximum  
3 A, mechanical service life  $2 \times 10^7$  switching cycles,  
electrical service life AC-14 at 3 A  $1 \times 10^5$  switching cycles,  
AC-14 at 0.5 A  $2 \times 10^6$  switching cycles  
  
PQC version: PQC 061xxxx-xx: 6 output relays  
AC-14 440 V AC, maximum 3 A or DC-13 125 V DC,  
maximum 3 A, mechanical service life  $1 \times 10^7$  switching  
cycles,  
electrical service life AC-14 at 3 A  $1 \times 10^5$  switching cycles,  
AC-14 at 0.5 A  $2 \times 10^6$  switching cycles

Common supply conductor P to the output relays maximum 10 A

Note: utilization category AC-14 / DC-13 as per IEC 60947-5-1  
For all PQC versions in areas where UL / CSA standards apply:

3 A 250 V AC  $\cos \varphi = 1$  at 85 °C  
3 A 30 V DC L/R = 0 ms at 85 °C

- Alarm contact

Volt-free, normally open,  
AC-14 250 V AC, maximum 3 A or DC-13 30 V DC, maximum 3 A, mechanical service life  $2 \times 10^7$  switching cycles, electrical service life AC-14 at 3 A  $1.5 \times 10^5$  switching cycles, AC-14 at 0.5A  $2 \times 10^6$  switching cycles  
Note: utilization category AC-14 / DC-13 as per IEC 60947-5-1

In areas where UL / CSA standards apply:

3 A 250 V AC  $\cos \varphi = 1$  at 85 °C  
3 A 30 V DC L/R = 0 ms at 85 °C

- Digital outputs

PQC version: PQC xxxxxxx-x1:

Up to  $5 \times 24$  V DC, 100 mA outputs, electrically interconnected with each other and the temperature input, alternatively usable as up to  $5 \times 5$ –24 V DC inputs.

## Interfaces

- Modbus RTU connection

PQC version: PQC xxxxxxx-2x:

120  $\Omega$  terminating resistor required at the end of the bus system

## Connections

- Instrument power AUX

Via pluggable screw terminals

Conductor cross section max. 2.5 mm<sup>2</sup>, min. 0.2 mm<sup>2</sup>,

PQC version: PQC xxx240x-xx:  
Insulation rating: min. 250 V AC, 80 °C

PQC version: PQC xxx480x-xx:  
Insulation rating: min. 500 V AC, 80 °C

- Protective earth PE

Via 6.3 mm female slide connector

Conductor cross section at least equal to the largest conductor cross section of the AUX phases, the voltage measurement connections, the output relays and the alarm connections; insulation colour yellow/green

- Voltage measurement inputs  
L1, L2, L3, N

Conductor cross section max. 2.5 mm<sup>2</sup>, min. 0.2 mm<sup>2</sup>

Insulation rating:  
Example 1: 230 V AC, select at least 250 V AC, 80 °C  
Example 2: 690 V AC, select at least 800 V AC, 80 °C

- Current measurement inputs  
L1, L2, L3, terminals S1 and S2 in each case

Conductor cross section max. 2.5 mm<sup>2</sup>, min. 0.2 mm<sup>2</sup>

Insulation rating: min. 250 V AC, 80 °C

- Output relays (control outputs, capacitor stages)

Conductor cross section max. 2.5 mm<sup>2</sup>, min. 0.2 mm<sup>2</sup>

PQC version: PQC xx0xxxx-xx: 250 V relays  
Insulation rating: min. 250 V AC, 80 °C

PQC version: PQC xx1xxxx-xx: 440 V relays:  
Insulation rating: min. 500 V AC, 80 °C

- Alarm contact Conductor cross section max. 2.5 mm<sup>2</sup>, min. 0.2 mm<sup>2</sup>  
Insulation rating: min. 250 V AC, 80 °C
- USB for updates (service interface) USB Micro-A and Micro-B ports
- Digital inputs and outputs PQC version: PQC xxxxxxx-1x:  
Conductor cross section max. 1.5 mm<sup>2</sup>, min. 0.14 mm<sup>2</sup>  
Insulation rating: 50 V DC, 80 °C
- Temperature inputs PQC version: PQC xxxxxxx-1x:  
Conductor cross section max. 1.5 mm<sup>2</sup>, min. 0.14 mm<sup>2</sup>  
Insulation rating: min. 50 V DC, 80 °C
- Modbus RTU connection PQC version: PQC xxxxxxx-2x:  
Conductor cross section max. 1.5 mm<sup>2</sup>, min. 0.14 mm<sup>2</sup>  
Insulation rating: min. 50 V DC, 80 °C

Note: 0.14 mm<sup>2</sup> = AWG 26; 0.2 mm<sup>2</sup> ≈ AWG 25;  
1.4 mm<sup>2</sup> ≈ AWG 16; 2.5 mm<sup>2</sup> = AWG 14

### Design data

- Dimensions W x H x D: 144 mm x 144 mm x 70 mm casing  
W x H x D: 144 mm x 165 mm x 70 mm including connectors
- Mounting Front of panel in 138 mm x 138 mm cutout to IEC 61554, held by four retaining lugs at the corners of the casing  
Maximum screw tightening torque 0.4 Nm
- Weight approx. 770 g without packaging
- Ingress protection Front of instrument when mounted in cabinet IP40, when mounted in cabinet with upgrade kit (Item No. 20-50015) IP54; rear of instrument and terminals IP20; all as per EN 60529  
Pollution degree 2 as per EN 61010-1:2011-07
- Electrical design Casing protection class I as per EN 61140  
Working voltage up to max. 760 V AC absolute value at voltage measurement inputs.  
TNV1 circuits, some of which interconnected: digital inputs and outputs, optional temperature inputs, optional Modbus connection.
- Casing design Flammability rating UL 94 V-0 according to casing manufacturer  
Impact resistance IK06 as per EN 61010-1:2011-07, 8.2.2
- Service life At +25 °C ambient temperature 15 years
- EMC EMC as per EN 61326-1  
EN 61000-4-2, electrostatic discharge: air 8 kV and contact 6 kV with horizontal and vertical coupling plane  
EN 61000-4-3, radiated immunity (EMS) 80 MHz – 1 GHz, horizontal and vertical, level 10 V/m = industrial environment radiation, Class A  
Hardware version V1.0: EN 55022A EMI 30 MHz – 1 GHz = industrial environment, Class A  
From hardware version V1.1: EN 55022A EMI 30 MHz – 1 GHz = office and residential area, Class B  
EN 61000-4-6, immunity to conducted disturbances, level 10 V RMS, 150 kHz – 80 MHz <sup>1</sup>

<sup>1</sup> The standard radio-frequency field test as per EN 61000-4-6 (EMC immunity) calls for amplitude modulation at a modulation frequency of 1 kHz. However, this frequency lies within the measurement range of the instrument in its intended use (20th harmonic of 50 Hz = 1 kHz). It is therefore to be expected that the measuring circuit clearly responds to this. For this reason, the radio-frequency field test can only be carried out without amplitude modulation.

EN 61000-4-4, burst immunity, 1 kV capacitive coupling, 2 kV injection into power supply cable and voltage measurement inputs

EN 61000-4-5 surge immunity, 2 kV injection into power supply cable and voltage measurement inputs

### Ambient conditions

- Temperature range
- Installation altitude

-20 °C to +60 °C, noncondensing

Maximum height above sea level 2000 m

### Measuring system

- Accuracy
- Averaging function
- Harmonics

Voltage and current measurement  $\pm 1\%$  of full scale reading at 50/60 Hz and 25 °C ambient temperature

Over 1 second, updated every 100 ms

Measured via Lx-N  
All even and uneven harmonics up to the 19th

## 3 Instrument description

### 3.1 FUNCTION

14

The PQC Power Quality Controller is a reactive power control relay. It continuously calculates the reactive and active power components of the supply network using the measurement data from the current path (current transformer) and the voltage path (voltage measurement connection). If the reactive power component exceeds certain thresholds, which the PQC has determined during the calibration procedure or which have been set as described, switching commands are given via the instrument outputs. If the inductive reactive power is greater than the value preset during instrument configuration (target  $\cos \phi$ ), after an adjustable time delay one or more of the PQC control contacts are closed. The PQC thus switches capacitor stages in as required in order to restore the target power factor. If the inductive reactive power component of the loads reduces again, this causes capacitor stages to be switched out. The PQC makes a variety of options possible for customizing the control settings to suit the individual application. The clear overview in the display provides effective monitoring of power factor correction. So-called 'cyclic switching' is a useful feature for prolonging the service life of the installation, since it ensures that all capacitor stages of the same power rating are on average switched in equally frequently.

### 3.2 REGENERATION

The PQC has a four-quadrant control function. If active power is fed back into the supply network, for example by combined heat and power systems, the PQC continues to correct for the reactive power drawn from the supply network. When this regeneration occurs, the active power P is displayed with a minus sign before it. Regeneration mode is also indicated by a symbol appearing on the display screen.

## 4 Mounting the instrument

### 4.1 SUITABLE LOCATION

See Section 1.3, Intended use.

Hardware version V1.0: This is a Class A device. In office and residential areas, it can cause interference to radio reception. In this case, it may be necessary to take appropriate precautions with the installation.

### 4.2 INSTALLING THE INSTRUMENT

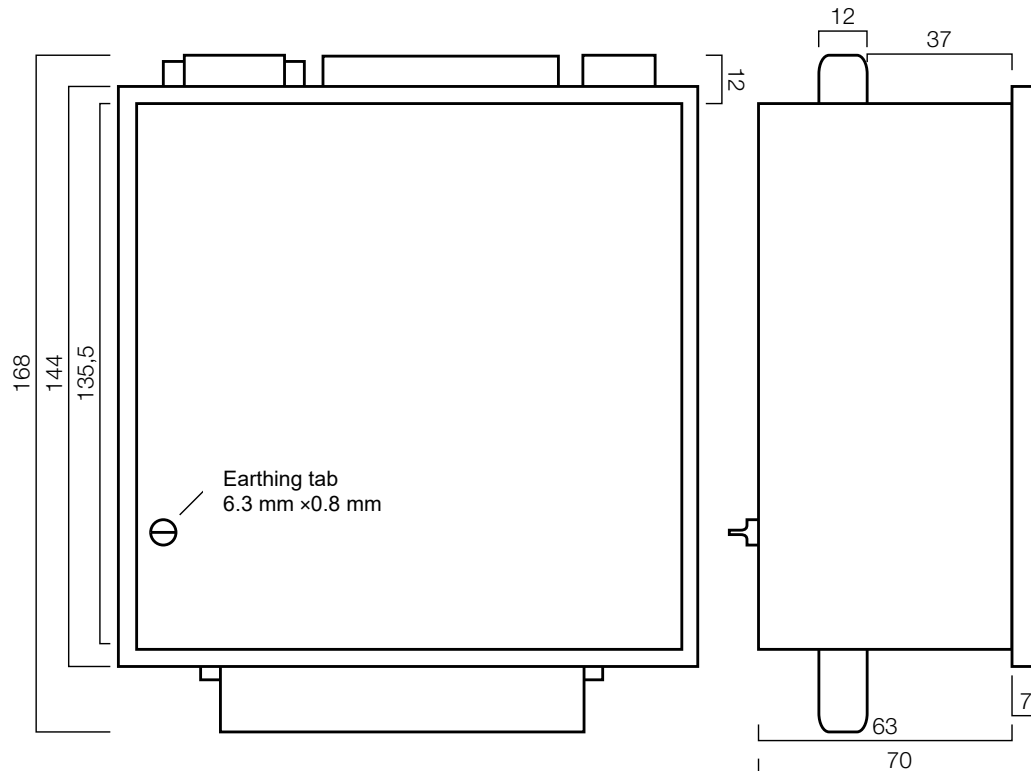

Figure 1 PQC dimensions in mm

#### Upgrade kit for IP54:

In the optional upgrade kit (type No. 20-50015) a gasket is available that must be used when mounting the PQC in control cabinets with IP54 ingress protection. It is fitted in the groove at the rear of the instrument's front panel (moulded polymer) before the PQC is mounted in the cutout. The gasket seals the gap between the PQC front panel and the wall of the control cabinet.

	<p><b>DANGER!</b> The rear of the panel-mounting PQC inside the control cabinet or enclosure only has IP20 ingress protection. Adequate protection against inadvertently touching live components must be provided, and the ingress of dust and water must be prevented by ensuring that the instrument is installed in a suitable enclosure (e.g. control cabinet or distribution panel).</p>
	<p><b>DANGER!</b> The PQC must <u>not</u> be installed in a hazardous zone, as its switching operations generate sparks that could ignite flammable gases. Only install the instrument in areas where there is no danger of a gas or dust explosion.</p>

The PQC is designed for mounting in a 138 mm x 138 mm cutout to IEC 61554 in the front of a control cabinet. It is held in place by four retaining lugs in the corners of the instrument.

**Fitting:**

- Preparation: the four retaining lugs at the corners of the instrument are swivelled to lie flat behind its front panel by turning the retaining screws (accessible from the front) anticlockwise.
- Insert the sheet-metal rear of the PQC through the cutout provided in the control cabinet until fully home (having first fitted the IP54 gasket in the groove behind the PQC front panel when appropriate).
- Press the PQC front panel gently against the control cabinet exterior and tighten the four retaining screws at the corners by turning them clockwise, applying a torque of no more than 0.4 Nm. This causes the retaining lugs to swivel outwards and be drawn toward the inner side of the cabinet wall until they are held tightly up against it.

**DANGER!**

To avoid accidents, the following must be observed:

- The PQC must be installed in accordance with its intended use before power is switched on.
- All the connectors supplied with the instrument must be plugged in.

If the above precautions are taken, the danger to life and limb can be significantly reduced.

**DANGER!**

To prevent the PQC overheating, the following must be observed:

- The PQC must be installed in an adequately ventilated space, and its rear and sidewalls must not be covered.
- No sources of heat must be located in the vicinity.
- The PQC must not be exposed to direct sunlight.

If the above safety precautions are taken, the risk of damaging equipment and assets or endangering life and limb can be significantly reduced.

**IMPORTANT SAFETY NOTICE!**

To avoid accidents, the following must be observed:

When the panel-mounting instrument is fitted in the front of a control cabinet for its intended use, there is a danger that its four retaining screws could become live and therefore a safety hazard if there is a fault in the wiring adjacent to the instrument. If a wire at a dangerous voltage works loose, it could make electrical contact with one of the four retaining screws. This means that it cannot be excluded that the head of the screw, which can be touched from outside the cabinet, could become live. In rare cases this could constitute a danger to life and limb.

At the location where the panel-mounting instrument is installed (e.g. control cabinet, enclosure), all wires and cables must be securely fastened or grouped in harnesses to ensure that any stray wire or strand cannot contact one or more of the instrument's retaining screws, thus making it or them live and therefore dangerous.

If the above safety precautions are taken, the risk of damaging equipment and assets or endangering life and limb can be significantly reduced.



## 5 Installation

### 5.1 ELECTRICAL CONNECTIONS

The instrument is connected as shown in the diagrams in Section 5.7.



#### **DANGER!**

The following instructions must be observed to avoid danger to life and limb:

- When the instrument is being installed or serviced, the instrument and the electrical system must be isolated from the power supply.
- The isolated electrical system must be locked out to prevent its being inadvertently switched on again.
- It must be verified that none of the terminals are live!
- The earthing tab must always be the first connection that is made (see Section 5.2, Earth connection).
- The power supply and voltage measurement terminals are live and must not be touched (risk of electric shock)!
- The measurement terminals L1, L2, L3 and N, the AUX power supply terminals and both alarm contacts must be short-circuited during any work carried out on the instrument.
- All live components in the vicinity must be covered to prevent inadvertent contact.
- If the power supply voltage and the voltage measured exceed the values specified in this operating manual and stated on the instrument, this may cause damage to the PQC. Consequential damage to other parts of the installation is also possible.
- The instrument power supply circuit AUX must be protected externally by a 2 A slow-blow 250 V AC fuse. One such fuse is required when the power is from an L–N connection, but two fuses must be installed if an L–L connection is used.
- A disconnecting device must be installed so that the connections of the PQC can be isolated from the electrical system and building electrical installations.
- Only the specified and appropriate voltages and signals may be connected to the respective terminals and ports provided for them.
- The cross-sectional areas of all cables used must be adequate for the purpose.
- Suitable measures must be taken to prevent cables operating at the power supply voltage being inadvertently pulled out and twisted.
- A disconnecting device, such as an isolator or circuit breaker, must be fitted in the building electrical installation in a suitable location, accessible by the user and appropriately labelled as a disconnecting device for the PQC. It must be able to isolate all cables operating at the power supply voltage from the instrument.
- If flexible stranded cables with their total cross-sectional area assembled from several fine filaments are used for the connections, ferrules must be crimped onto their ends. It must be ensured that no individual filament has been left out of the ferrule.

When work is carried out on the connecting cables and the instrument terminals, it is possible that live components may be touched inadvertently. If this occurs, the voltage present may be injurious to health or may even have fatal consequences.

The risk to life and limb can be significantly reduced by observing the above safety precautions.

	<p><b>NOTE!</b></p> <p>The instrument can be damaged by incorrect operation.</p> <ul style="list-style-type: none"> <li>• Only the specified and appropriate voltages and signals may be connected to the respective terminals and ports provided for them.</li> <li>• The cross-sectional areas of all cables used must be adequate for the purpose.</li> <li>• The required cable types are specified in Section 2, Technical data.</li> </ul> <p>If any incorrect cables, voltages or signals are applied to the terminals, this can result in damage to the PQC and the electrical installation.</p>
---	--

	<p><b>DANGER!</b></p> <p>To avoid accidents, the following must be observed:</p> <p>At the PQC installation site (e.g. control cabinet, enclosure), all wires and stranded cables must be adequately secured or grouped in harnesses to ensure that no conductor can work free and touch one or more of the instrument retaining screws so as to make them live and a source of danger.</p> <p>If the above safety precautions are taken, the risk of damaging equipment and assets or endangering life and limb can be significantly reduced.</p>
---	--

	<p><b>NOTE!</b></p> <p>If flexible stranded cables used for the connections, insulated 'short' ferrules 6 mm in length must be crimped onto their ends.</p>
---	---

## 5.2 EARTH CONNECTION

	<p><b>DANGER!</b></p> <p>To avoid accidents, the following must be observed:</p> <ul style="list-style-type: none"> <li>• The earthing conductor PE must always be connected to the PQC instrument casing before any other connections are made.</li> <li>• The PE conductor cross section must be at least equal to that of the largest conductor of the AUX phases, the voltage measurement connections, the output relays or the alarm connections. Its insulation colour is yellow/green. Earthing connections for network power circuits must have at least the same current-carrying capacity rating as the circuits themselves.</li> <li>• If the earthing tab has broken off, the PQC must not be started up. The instrument must either be repaired or replaced.</li> <li>• The PQC may only be put into service when the earthing conductor is connected to it.</li> </ul> <p>If the above safety precautions are taken, the risk of damaging equipment and assets or endangering life and limb can be significantly reduced.</p>
---	---



The earthing conductor PE must always be connected to the PQC instrument casing. An earthing tab is provided for this in the rear wall of the casing. It is marked with the earthing symbol as per EN 60617-2 shown at left.

### 5.3 SUPPLY VOLTAGE

The instrument power supply circuit AUX must be protected externally by a fuse, either

- 2 A slow-blow, 250 V AC (PQC version: PQC xxx240x-xx), or
- 2 A 500 V AC time delay (PQC version: PQC xxx480x-xx).

One such fuse is required when the power is from an L–N connection, but two fuses must be installed if an L–L connection is used.

A disconnecting device must be installed so that the connections of the PQC can be isolated from the electrical system and building electrical installations.

The connection diagrams (see Section 5.7) show instruments with 6 or 12 output relays.



**DANGER!**

To avoid accidents, the following must be observed:

- The safety instructions in Section 5.1, Electrical connections
- Connection of the instrument power supply as specified in this manual
- Not exceeding the specified maximum operating voltage at the AUX power supply terminals (see Section 2, Technical data)

When work is carried out on the instrument terminals and connecting cables, there is a risk of live components being touched inadvertently. The working voltage may present a hazard to health or may even be life-threatening.

If the above instructions are followed, and the precautions specified in Section 1.2, Safety instructions, are taken, the risk of damaging equipment and assets or endangering life and limb can be significantly reduced.

With these instrument types (see Section 9, Instrument versions), provided that the specified voltage limits are not exceeded, it is possible to use **phase–phase** or **phase–neutral** connections. For typical examples, see Figures 8 and 9.



**CAUTION!**

- The cables and the earthing conductor leading to the instrument must be permanently connected. It is not permitted for these to have plug-in connections, except for those connectors supplied with the instrument.
- An external disconnecting device, such as an isolator or circuit breaker, must be fitted in the power supply line to the instrument. This must be located in the vicinity of the PQC and must be able to isolate all cables connected to the AUX terminals. It must be suitable for this application, comply with the requirements of IEC 60947-1 and IEC 60947-3, and be appropriately labelled as a disconnecting device for the PQC. This device must not disconnect the earthing conductor.

## 5.4 VOLTAGE MEASUREMENT

Depending on the instrument type (see Section 9, Instrument versions), the PQC can measure one, two or three AC voltages. The voltage measurement inputs are electrically interconnected via high resistances. See Section 2, Technical data, for the measurement ranges. DC voltages cannot be measured.

The PQC voltage measurement inputs are designed for 100–690 V AC networks. It is possible to measure medium voltages using an x/100 V transformer.

It is not necessary to provide external overcurrent protection in the voltage measurement circuits since these are safety impedance-protected. In this case, a short-circuit-proof cable (double insulated stranded wire) must be used to connect the voltage measurement inputs.

20



### DANGER!

To avoid accidents, the following must be observed:

- The safety instructions in Section 5.1, Electrical connections.

When work is carried out on the instrument terminals and connecting cables, there is a risk of live components being touched inadvertently. The working voltage may present a hazard to health or may even be life-threatening.

If the above instructions are followed, and the precautions specified in Section 1.2, Safety instructions, are taken, the risk of damaging equipment and assets or endangering life and limb can be significantly reduced.

### Instrument types with single-phase measurement (see Section 9, Instrument versions):

For single-phase measurement, the terminals L1 and N are connected as shown in the connection diagrams in Section 5.7. The voltage can be measured between any two phases or between any phase and neutral.

### Instrument types with 3-phase measurement (see Section 9, Instrument versions):

For 3-phase measurement, the terminals **L1**, **L2**, **L3** and **N** are connected as shown in the connection diagrams in Section 5.7. Phases L1, L2 and L3 must be connected in correct phase sequence.

If an instrument of the 3-phase type is used for single-phase measurement, only the terminals **L1** and **N** are to be used. In this case, it is necessary to connect the terminals **L2** and **L3** to terminal **N** in order to avoid false readings being obtained.

For 3-phase measurement, it is advisable to connect the **N** terminal as well. This enables the high measurement accuracy of the PQC to be achieved when measuring phase–neutral voltages and the parameters derived from these. If no neutral conductor is present, the **N** terminal can be left unconnected. However, this is only advisable when the phases are symmetrically loaded.



### NOTE!





With instrument types designed for three-phase measuring, the voltage measurement inputs not in use must be commoned with the terminal **N**. This is necessary, for example, with single- or two-phase connections.

If this is not done, phantom measurement readings may be displayed for the inputs that are not in use.

With three-phase measurement, automatic connection identification is not possible.

## 5.5 CURRENT MEASUREMENT

The PQC is designed for connection to x/1 A and x/5 A current transformers. Only AC currents can be measured; DC currents cannot be measured. Depending on the instrument type (see Section 9, Instrument versions), the PQC can measure one, two or three AC currents. See Section 2, Technical data, for the measurement ranges.

	<p><b>DANGER!</b></p> <p>If live current transformer circuits are interrupted, there is the danger that arcing may occur, which would cause electric shock, burns or eye injuries. In addition, red-hot metal particles could be spattered, which apart from the health hazard also constitute a fire risk.</p> <p>To avoid accidents, the following must be observed:</p> <ul style="list-style-type: none"> <li>• The safety instructions in Section 5.1, Electrical connections</li> <li>• The current measurement inputs must be connected as specified.</li> <li>• The retaining screws on the connectors must be tightened to prevent the connectors accidentally working loose.</li> <li>• The secondary-side connections of the current transformers must be short-circuited before the circuits to the PQC are interrupted or the connector removed!</li> </ul> <p>When work is carried out on the instrument terminals and connecting cables, there is a risk of live components being touched inadvertently. The working voltage may present a hazard to health or may even be life-threatening.</p> <p>If the above instructions are followed, and the precautions specified in Section 1.2, Safety instructions, are taken, the risk of damaging equipment and assets or endangering life and limb can be significantly reduced.</p>
	<p><b>DANGER!</b></p> <p>The retaining screws on the sides of the connectors for the current transformer circuits must always be tightened before the instrument is put into service.</p> <p>Tightening these retaining screws prevents the connectors from accidentally working loose and therefore reduces the risk of arcing.</p>
	<p><b>DANGER!</b></p> <p>If an earth terminal is provided at the secondary side of the current transformer, this must be connected to an earthing conductor!</p> <p>In general, it is recommended that all current transformer circuits be earthed.</p>
	<p><b>CAUTION!</b></p> <p>The following must be observed to ensure safe and reliable operation:</p> <ul style="list-style-type: none"> <li>• The connection of the current measurement inputs must be via an external, electrically isolating current transformer.</li> <li>• Overloading of the current transformers incorporated in the instrument must be avoided. The maximum allowable continuous current is 6 A AC; transient peaks 10 A.</li> </ul> <p>These measures must be taken to ensure that the instrument is not damaged.</p>
	<p><b>CAUTION!</b></p> <p>The instrument terminals can become hot during operation.</p> <ul style="list-style-type: none"> <li>• After the PQC has been operating, sufficient time must be allowed for the instrument and its terminals to cool down before work is carried out on the terminals.</li> </ul> <p>Compliance with this stipulation will avoid the risk of burns.</p>

**Instrument types with single-phase measurement (see Section 9, Instrument versions):**  
The current in any desired phase L is measured via an external, electrically isolating current transformer.  
See Section 2, Technical data, for the measurement range.

The terminals L1 – S1-S2 are connected as shown in the connection diagram in

Figure 2.

**Instrument types with 3-phase measurement (see Section 9, Instrument versions):**  
The currents in phases L1, L2 and L3 are measured via external, electrically isolating current transformers.  
See Section 2, Technical data, for the measurement range.

The terminals **L1 – S1-S2**, **L2 – S1-S2** and **L3 – S1-S2** must be connected as shown in the connection diagram in Figure 3, in correct phase sequence.

Unassigned current measurement inputs can be left unconnected.



**NOTE!**



In networks with a nominal voltage of 1000 V and more, the regulations call for the current transformer circuits to be earthed.

Note: In general, it is recommended that all current transformer circuits be earthed.

If networks with a nominal voltage of 1000 V or over are left unearthed, damage may occur to the instrument.

With three-phase measurement, automatic connection identification is not possible.

## 5.6 OUTPUT RELAYS (CONTROL OUTPUTS)

	<p><b>DANGER!</b></p> <p>To avoid accidents, the following must be observed:</p> <ul style="list-style-type: none"> <li>• The safety instructions in Section 5.1, Electrical connections.</li> <li>• The output relays must be connected as set out in this operating manual.</li> <li>• The working voltage of the relay contacts must not exceed the specified maximum level. Please refer to Section 2, Technical data.</li> </ul> <p>When work is carried out on the instrument terminals and connecting cables, there is a risk of live components being touched inadvertently. The working voltage may present a hazard to health or may even be life-threatening.</p> <p>If the above instructions are followed, and the precautions specified in Section 1.2, Safety instructions, are taken, the risk of damaging equipment and assets or endangering life and limb can be significantly reduced.</p>
	<p><b>CAUTION!</b></p> <p>The following must be observed to ensure safe and reliable operation:</p> <ul style="list-style-type: none"> <li>• Each of the output relay connections Q1 to Q12 may carry a current of no more than 3 A AC. See Section 2, Technical data.</li> <li>• The common pole P of the output relays may carry a current of no more than 10 A AC. See Section 2, Technical data.</li> </ul> <p>Compliance with these stipulations will avoid the risk of fire or possible damage to the instrument.</p>
	<p><b>CAUTION!</b></p> <p>The instrument terminals can become hot during operation.</p> <ul style="list-style-type: none"> <li>• After the PQC has been operating, sufficient time must be allowed for the instrument and its terminals to cool down before work is carried out on the terminals.</li> </ul> <p>Compliance with this stipulation will avoid the risk of burns.</p>

Depending on instrument type, the PQC is equipped with 6 or 12 output relays (control outputs). Capacitors are connected to these via current-amplifying electromechanical devices (relays, contactors).

Connections are made to the terminals 'Output relays Q1 to Q12, P' as shown in the connection diagrams in Section 5.7.

In the case of the instrument versions with 6 output relays, the connections are made to the terminals 'Output relays Q1 to Q6, P'.

The terminal **P** is used for connecting the common feed to the output relays.

If not all of the available output relays are to be used, it is recommended to connect the output cables starting with output 1 and leaving no gaps.

# 5.7 CONNECTION DIAGRAMS OF ALL PQC INSTRUMENT TYPES

## 5.7.1 Connection diagram: version PQC 1202401-XX

24

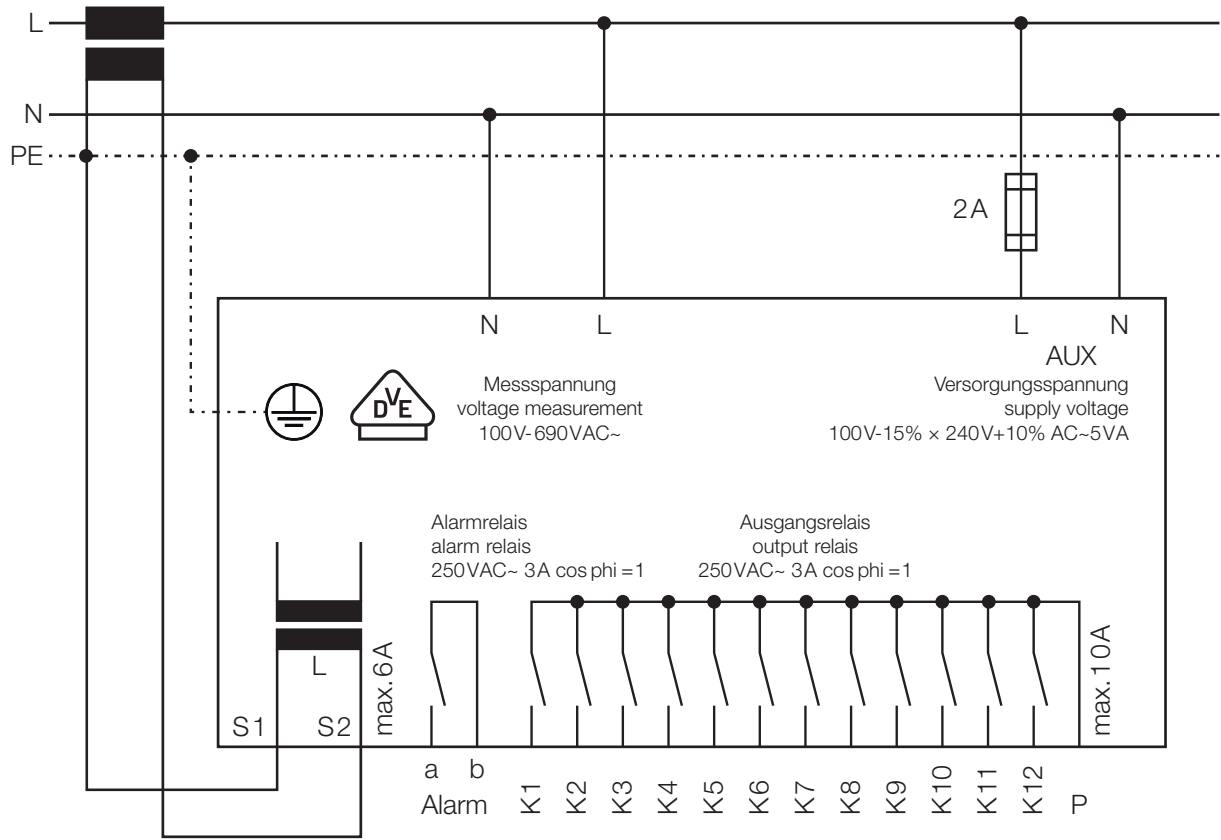

Figure 2 Connection diagram for PQC 1202401-XX



### 5.7.2 Connection diagram: version PQC 1202403-XX

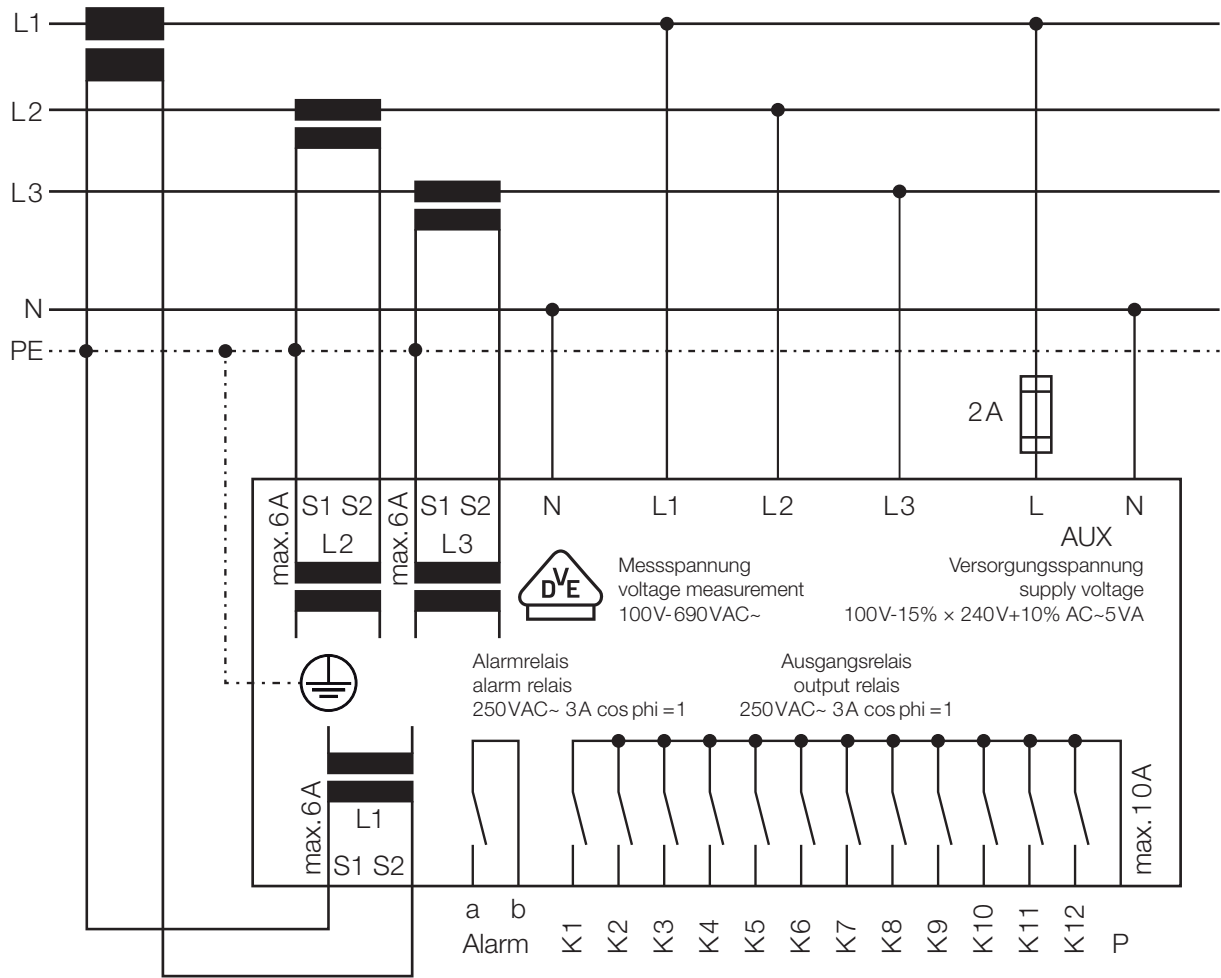

Figure 3 Connection diagram for PQC 1202403-XX

### 5.7.3 Connection diagram: version PQC 0602401-XX

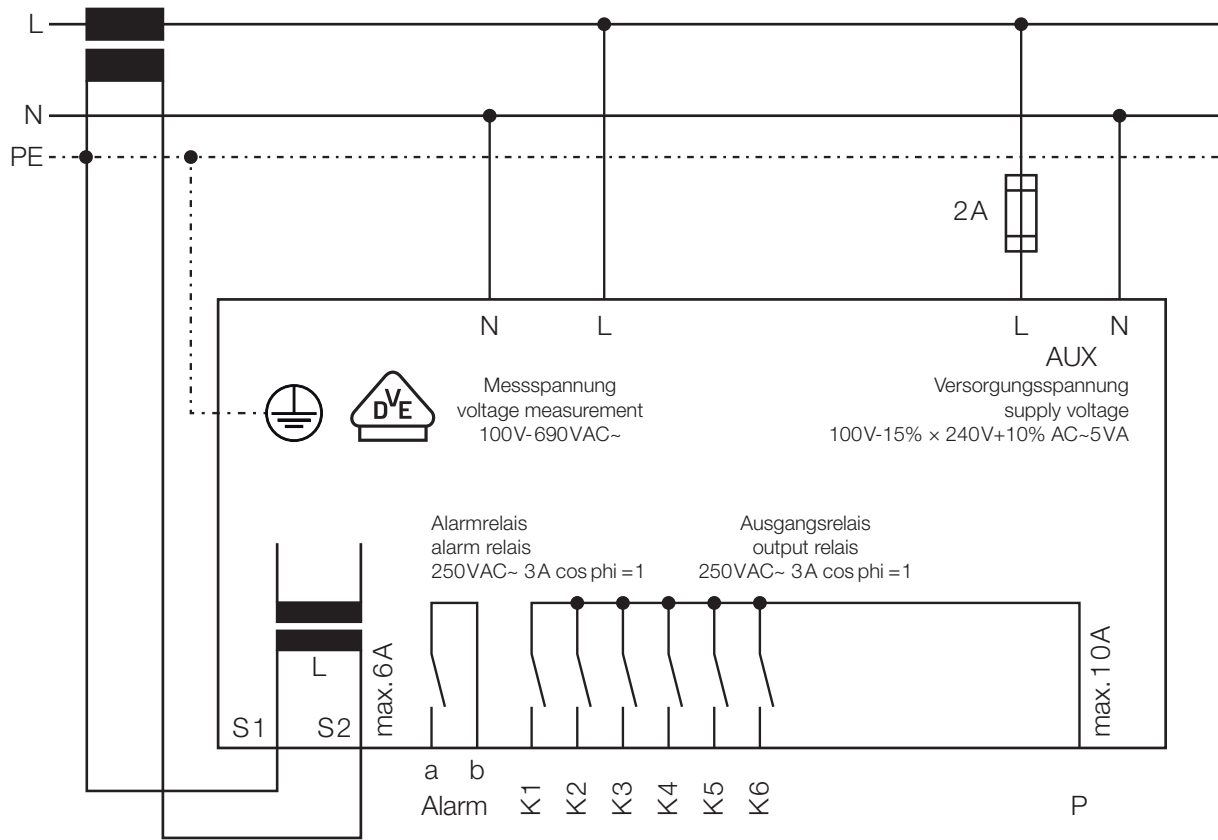

Figure 4 Connection diagram for PQC 0602401-XX

### 5.7.4 Connection diagram: version PQC 1204801-XX

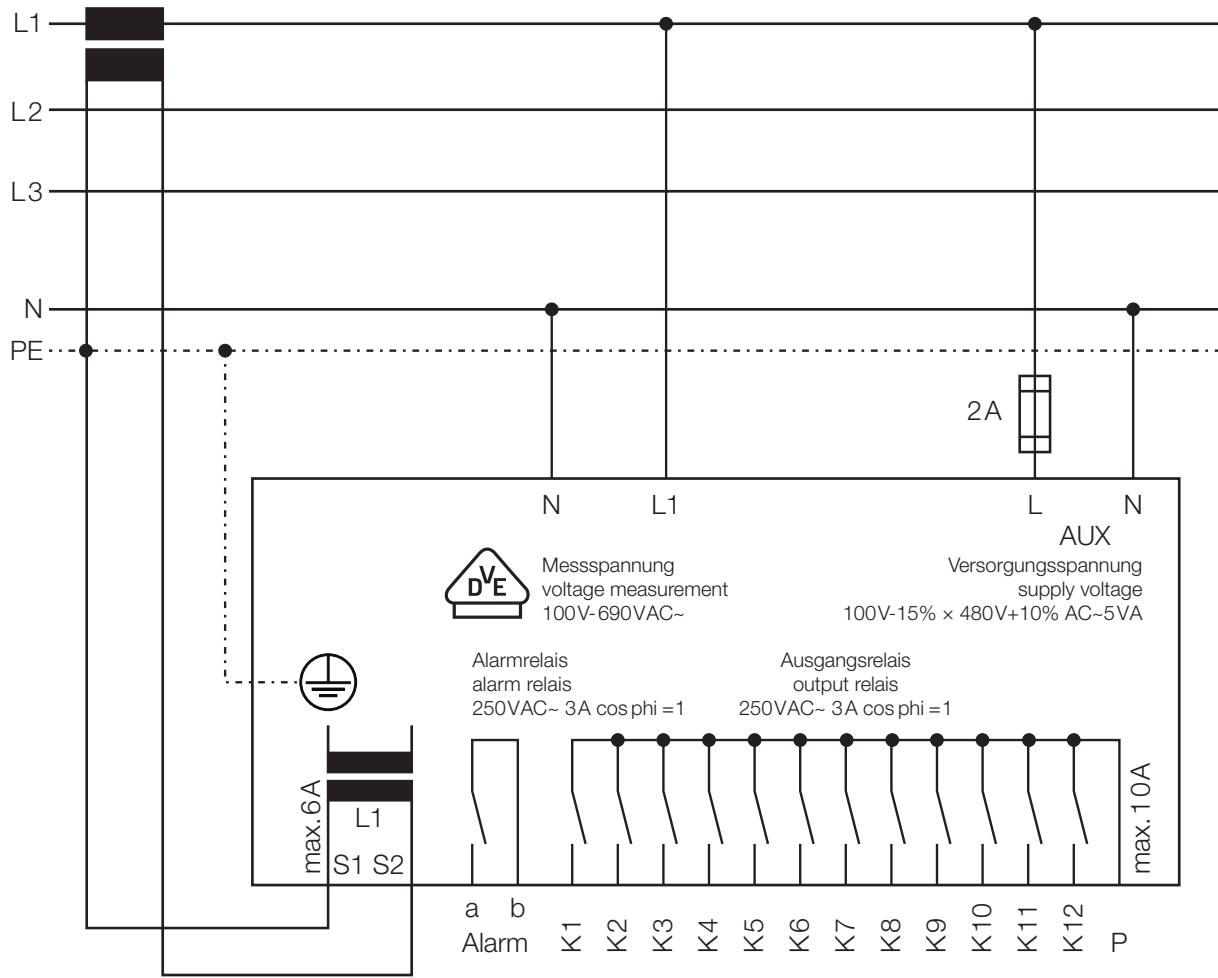

Figure 5 Connection diagram for PQC 1204801-XX

### 5.7.5 Connection diagram: version PQC 1204803-XX

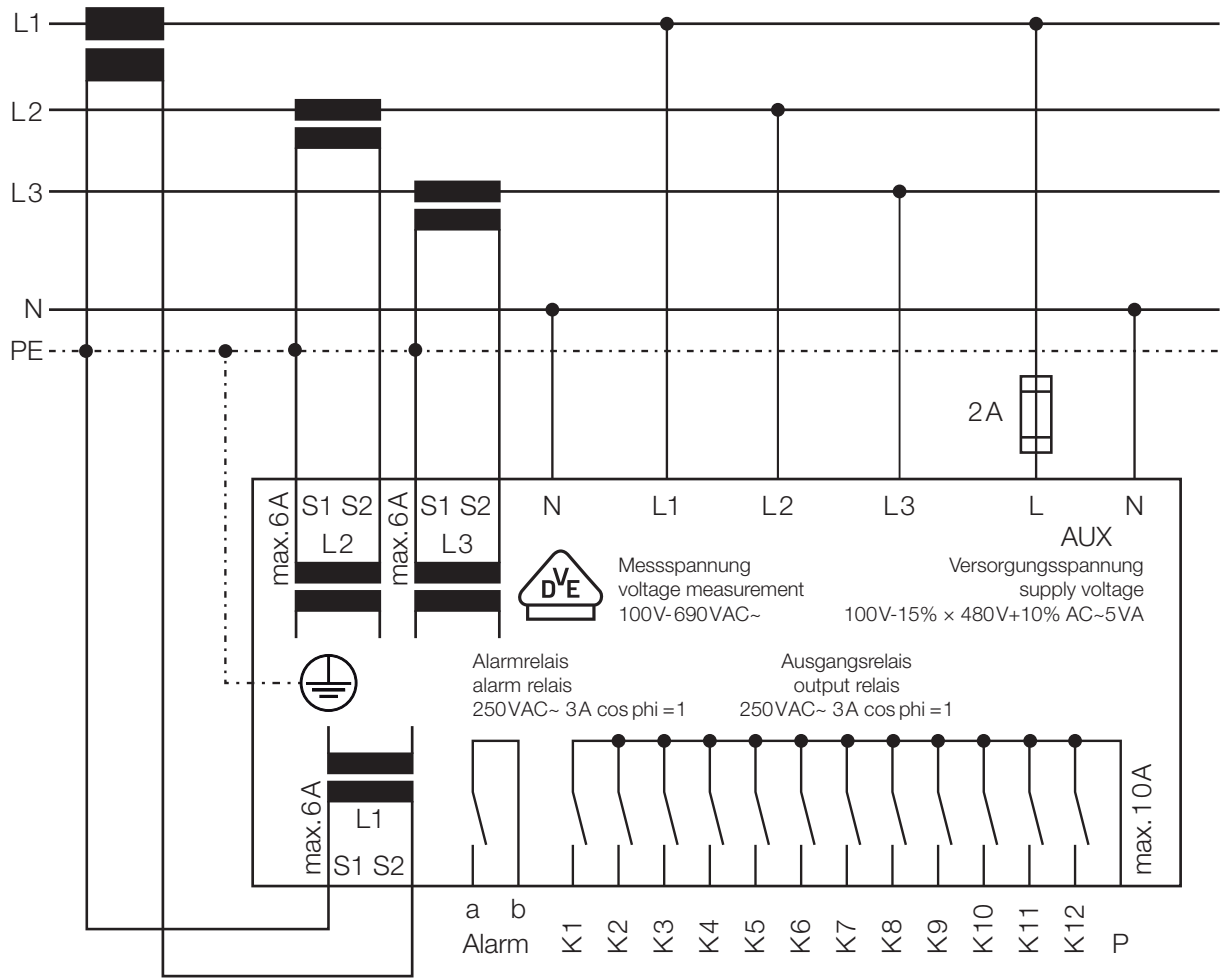

Figure 6 Connection diagram for PQC 1204803-XX

### 5.7.6 Connection diagram: version PQC 0614801-XX

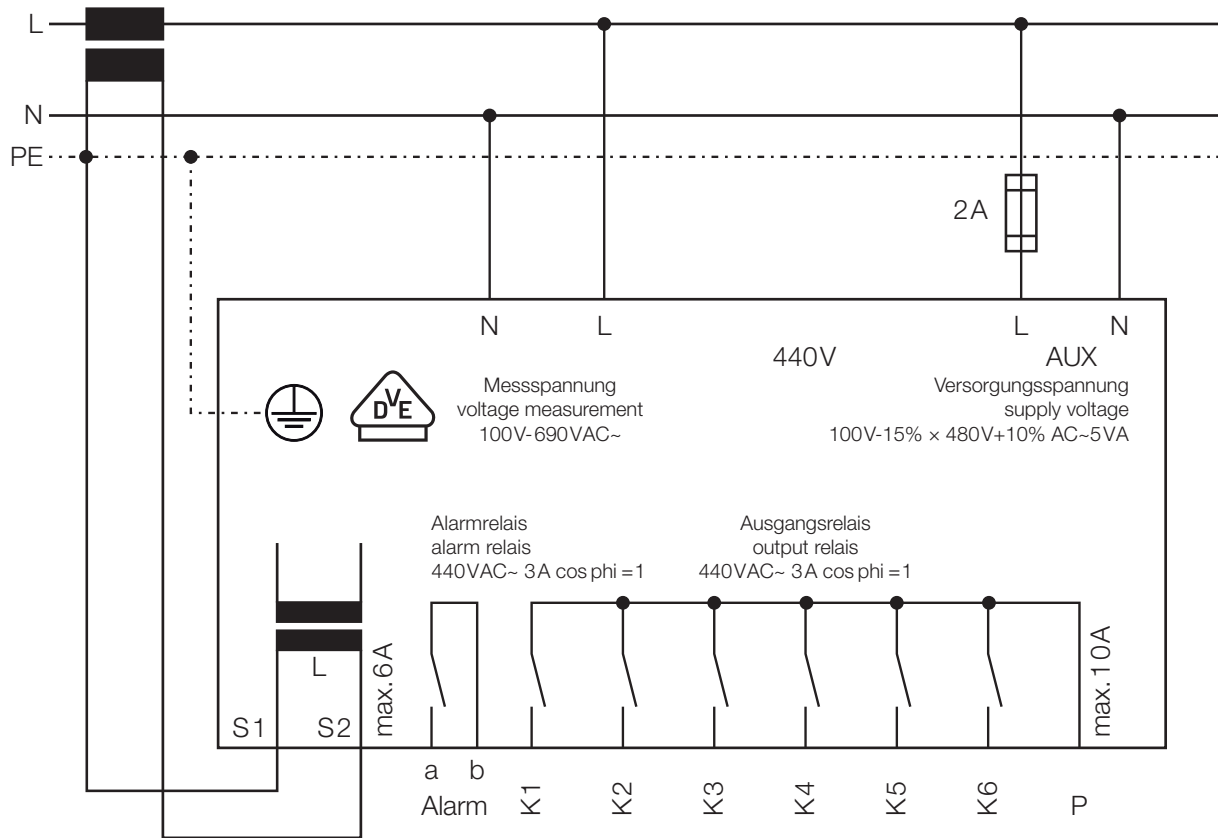

Figure 7 Connection diagram for PQC 0614801-XX

## 5.7.7 Options for connecting the AUX power supply for PQC XXX480X-XX versions

Connecting the AUX terminals to a 100 to 480 V AC power supply.

Version: PQC XXX480X-XX:

400 V AC / 415 V AC – networks without a neutral conductor N

30

### 5.7.7.1 Connection diagram for 400/415 V networks with no neutral conductor

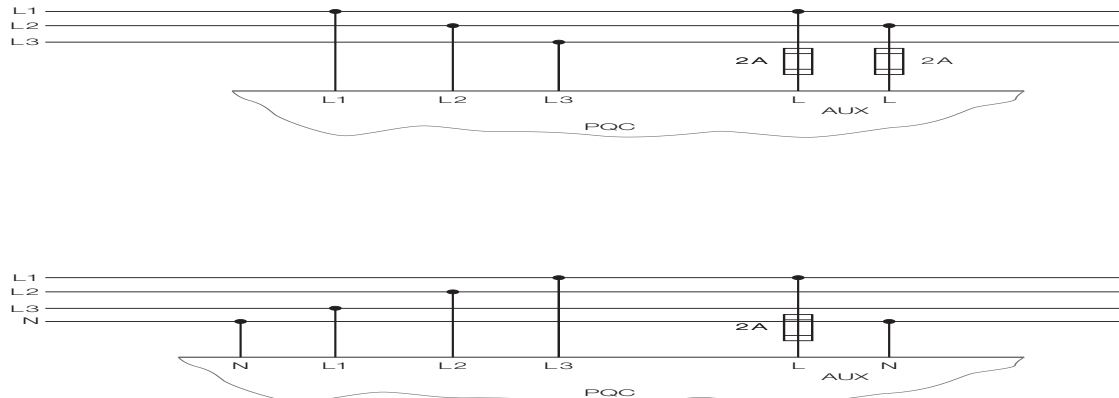

Figure 8 Part of the connection diagram for 400/415 V networks with no neutral conductor

Version: PQC XXX480X-XX:

690 V AC – Networks with a neutral conductor N (voltage phase–neutral N = 400 V AC)

### 5.7.7.2 Connection diagram for 690 V networks with a neutral conductor

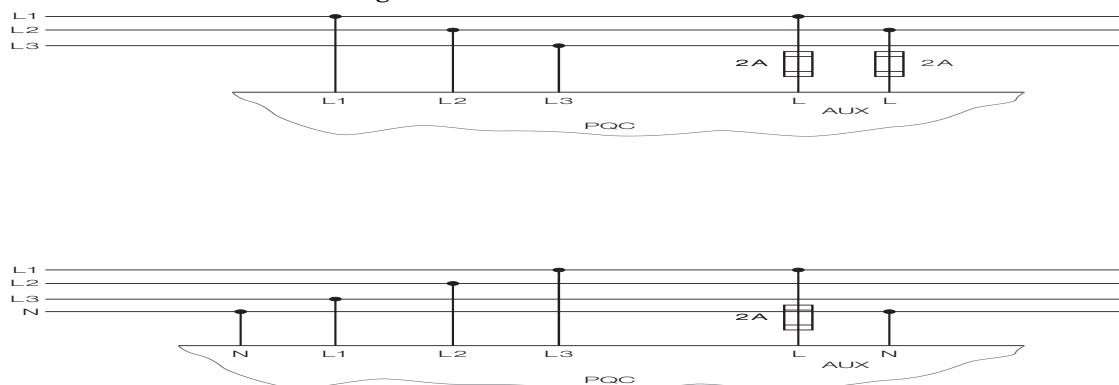

Figure 9 Part of the connection diagram for 690 V networks with a neutral conductor

## 6 Commissioning (Initial start-up)



### DANGER!

To avoid accidents, the following must be observed:

The PQC must be installed in accordance with its intended use before power is switched on.

All the connectors supplied with the instrument must be plugged in, and the earth connection must be made.

Before start-up, it must be ensured, for example by means of a closed door or a suitable cover, that the instrument terminals can no longer be touched.

If the instrument terminals and connecting cables are exposed during operation, there is a risk of live components being touched inadvertently. The working voltage may present a hazard to health or may even be life-threatening.

If the above instructions are followed, and the precautions specified in Section 1.2, Safety instructions, are taken, the risk of damaging equipment and assets or endangering life and limb can be significantly reduced.

### 6.1 ALARM FUNCTION

Alarm signals generated internally in the instrument can be assigned to the volt-free contact of the alarm relay. These alarm signals can comprise status signals, status of the optional digital inputs, set alarm limits exceeded or instrument faults.

The assignment of the internal PQC alarm signals to the alarm relay is carried out in a menu dialogue (see Section 8.5.3.2, Alarm management).

The terminals **Alarm a** and **Alarm b** are connected as shown in the connection diagrams in Section 5.7, Connection diagrams of all PQC instrument types. See Section 2, Technical data, for the contact rating.

#### 6.1.1 List of alarms and messages

- $\cos \varphi$  alarm - Given if PQC cannot adjust  $\cos \varphi$  into the control band.
- Undervoltage - Given if measured voltage drops below the set limit.
- Undercurrent - Given if measured current falls below 15 mA.
- Overcurrent - Given if ratio  $I_{rms}/I_{50Hz/60Hz}$  exceeds the set limit.
- TDHI - Given if THDI exceeds the set limit.
- Switching cycles - Given if the number of switching cycles for the contactors exceeds the set limit.
- V harmonic - Given if a harmonic voltage exceeds the set limit.
- I harmonic - Given if a harmonic current exceeds the set limit.
- Zero stage (dud) detected - Given if a capacitor stage in operation loses more corrective power than the set limit.
- Voltage blackout detected - Given if the power supply is interrupted for longer than  $x \frac{1}{4}$  cycles.
- Connection not identified - Given if the connection has not been identified during initial start-up.
- Stages not identified - Given if the corrective power of the capacitor stages has not been identified during initial start-up.

## 6.2 SAFETY PRECAUTIONS BEFORE START-UP

After all installation work has been carried out as described in Section 5, Installation, and the above safety instructions have been complied with, the power supply may be switched on and the PQC started up.

32

## 6.3 FUNCTIONAL CHECKOUT

Once the power has been switched on, it takes several seconds until the PQC starts up. The backlighting of the LCD display is the first visible indication, then, after about five seconds, the PQC is ready for operation. Information is displayed on the LCD screen, and the PQC can be operated by means of the keys.



Figure 10 PQC Start screen (firmware version number may be different)

## 6.4 CONFIGURATION

The PQC is configured using the keys to navigate the menu (see Table 3 Key functions).

## 6.5 AUTOMATIC COMMISSIONING

If **Detection** is selected in the **Initial start-up** menu, then **Stage + connection** and confirmed with **Continue**, the instrument carries out the capacitor stage and connection identification procedure automatically.



## 6.5.1 Automatic connection identification

When the operating voltage is applied to the instrument for the first time, and **Continue** is selected in the **Initial start-up** dialogue, it is possible that the PQC automatically carries out the connection identification procedure, i.e. the instrument itself identifies in which phase angle the current and voltage paths are connected. If the PQC does not succeed in this, for example because the network is very unstable, the calibration procedure should be repeated under more stable network conditions. It is also possible to enter the phase angle (connection type) manually, see Section 8.1, PQC initial start-up. Table 1 below shows the appropriate connections for current transformers.

Automatic connection identification is **not** possible with 3-phase measurement. The voltage and current inputs must be connected in correct phase sequence.

Table 1 Connection types for current transformers in L1, L2 and L3

Connection type	Connection to voltage path					
	L/N –	L	L/N –	L	L/N –	L
0	L1 –	N	L2 –	N	L3 –	N
1	L1 –	L3	L2 –	L1	L3 –	L2
2	N –	L3	N –	L1	N –	L2
3	L2 –	L3	L3 –	L1	L1 –	L2
4	L2 –	N	L3 –	N	L1 –	N
5	L2 –	L1	L3 –	L2	L1 –	L3
6	N –	L1	N –	L2	N –	L3
7	L3 –	L1	L1 –	L2	L2 –	L3
8	L3 –	N	L1 –	N	L2 –	N
9	L3 –	L2	L1 –	L3	L2 –	L1
10	N –	L2	N –	L3	N –	L1
11	L1 –	L2	L2 –	L3	L3 –	L1
<b>Current transformer in:</b>		↑ <b>L1</b>		↑ <b>L2</b>		↑ <b>L3</b>

## 6.5.2 Automatic identification of the connected capacitor stages

Having performed the connection identification procedure, the PQC then carries out the automatic capacitor stage identification process (c/k setting). During this calibration procedure, all the control contacts of the instrument are individually closed and opened again several times. This identifies the switching sequence, but the procedure can take several minutes.

Later, during normal operation, the PQC checks its saved parameters at certain intervals of time. If a capacitor stage fails, after a certain time this will be identified as a zero stage (with zero power rating) and no longer used in the regular control process. All zero stages are switched in again from time to time to check their power rating. If a capacitor stage has been retrofitted or defective fuses have been replaced, the PQC will identify this after some time and the stage will be reintegrated in the control process. We recommend, however, that a new calibration procedure be initiated after a stage has been replaced.

Note: If the low voltage network is fed from several transformers arranged in parallel, the capacitor current is distributed between all the transformers. If the measurement is not carried out via summation current transformers, the change in the current measurable by the PQC when capacitor stages are switched in is too small, which may result in errors in the automatic capacitor stage identification process. We therefore recommend that in such situations the automatic capacitor stage identification function be disabled and the appropriate parameters (c/k setting, switching sequence and number of capacitor stages) programmed manually (see Section 8.1).

### 6.5.3 Calculation of c/k

Formula 1 Calculation of c/k

$$I_A = 0.65 \times \frac{Q_{\text{smallest stage}}}{V \times \sqrt{3} \times k} \times 1000 \approx 0.375 \times \frac{Q_{\text{smallest stage}}}{V \times k} \times 1000 \quad [mA]$$

Kann die Formel etwas schöner umgesetzt werden?  
(Die ist nicht das Kreuzprodukt gemeint.)

where





- $I_A$  = Response current in mA to be set
- $Q_{\text{smallest stage}}$  = Capacitor power rating of the smallest stage in var (not the total system power rating)
- $V$  = Network voltage in volts at the primary side of the current transformer
- $k$  = Transformer ratio (*primary side ÷ secondary side*)

Table 2 c/k settings at 400 V AC and 50 Hz

<b>c/k settings for 400 V AC 50 Hz networks</b>															
Current		Stage rating (not total) in kvar of the power factor correction system													
A /A	k	2.5	5	6.25	7.5	10	12.5	15	20	25	30	40	50	60	100
<b>30 /5</b>	6	400	800	980	1200	1600									
<b>40 /5</b>	8	300	600	740	900	1200	1500								
<b>50 /5</b>	10	240	480	590	720	960	1200	1440							
<b>60 /5</b>	12	200	400	490	600	800	1000	1200	1600						
<b>75 /5</b>	15	160	320	390	480	640	800	960	1280	1600	1920				
<b>100 /5</b>	20	120	240	300	360	480	600	720	960	1200	1440	1920			
<b>150 /5</b>	30	80	160	200	240	320	400	480	640	800	960	1280	1600	1920	
<b>200 /5</b>	40	60	120	150	180	240	300	360	480	600	720	960	1200	1440	
<b>250 /5</b>	50	50	100	120	140	190	240	290	380	480	580	770	960	1150	1920
<b>300 /5</b>	60	40	80	100	120	160	200	240	320	400	480	640	800	960	1600
<b>400 /5</b>	80	30	60	80	90	120	150	180	240	300	360	480	600	720	1200
<b>500 /5</b>	100	20	50	60	70	100	120	140	190	240	290	380	480	580	960
<b>600 /5</b>	120		40	50	60	80	100	120	160	200	240	320	400	480	800
<b>750 /5</b>	150		30	40	50	60	80	100	130	160	190	260	320	380	640
<b>1000 /5</b>	200		20	30	40	50	60	70	100	120	140	190	240	290	480
<b>1500 /5</b>	300			20	20	30	40	50	60	80	100	130	160	190	320
<b>2000 /5</b>	400					20	30	40	50	60	70	100	120	140	240
<b>2500 /5</b>	500						20	30	40	50	60	80	100	120	190
<b>3000 /5</b>	600							20	30	40	50	60	80	100	160
<b>4000 /5</b>	800								20	30	40	50	60	70	120
<b>5000 /5</b>	1000									20	30	40	50	60	100
<b>6000 /5</b>	1200										20	30	40	50	80
<b>7000 /5</b>	1400											20	30	40	70





If the ratings of the stages and the current transformers are not to be found in the table, or the nominal voltage of the power factor correction system is different, the above formula must be used to calculate the c/k setting.

## 7 Description of the menu

Key					
Action	PQC overview	Up	Down	Start submenu	Display information

The instrument is operated with the following keys:

Table 3 Key functions

Icon	Key	Function
	Escape	Go back one level in the system tree.
	Up	Increase a selected parameter. Select another menu item above.
	Down	Decrease a selected parameter. Select another menu item below.
	Return / Enter	One level lower in the system tree (e.g. selecting a highlighted parameter). Select and confirm a selected element (e.g. adopt value).
	Info	Help text

The PQC can be operated in three languages, which are selected from the main menu via Initial start-up → Language (see Section 8.1):

- **German**
- **English**
- **French**

# 7.1 MENU OVERVIEW

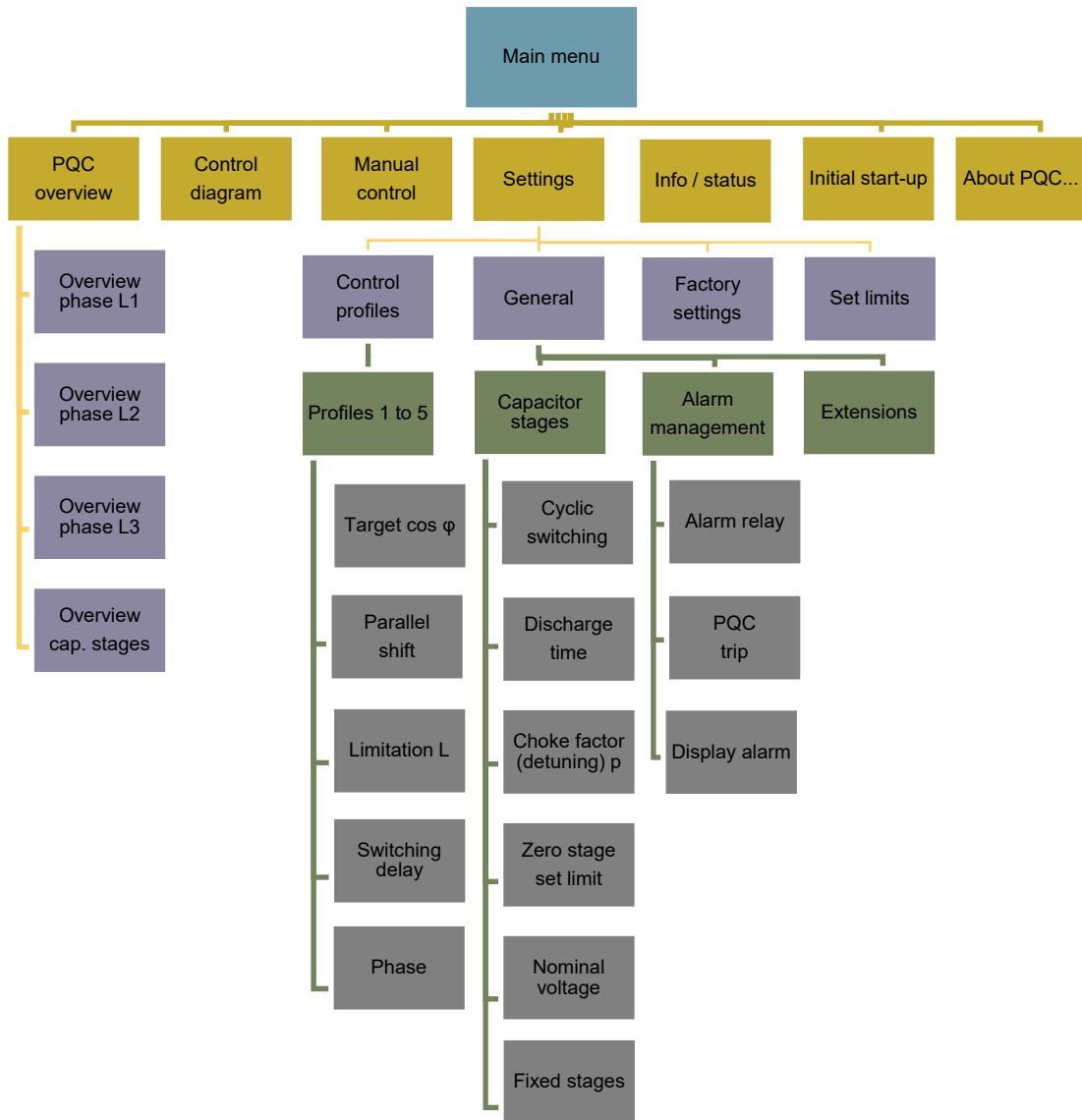

Menu levels: Level 1 = blue, Level 2 = yellow, Level 3 = violet, Level 4 = green, Level 5 = grey

Figure 11 Menu structure 1

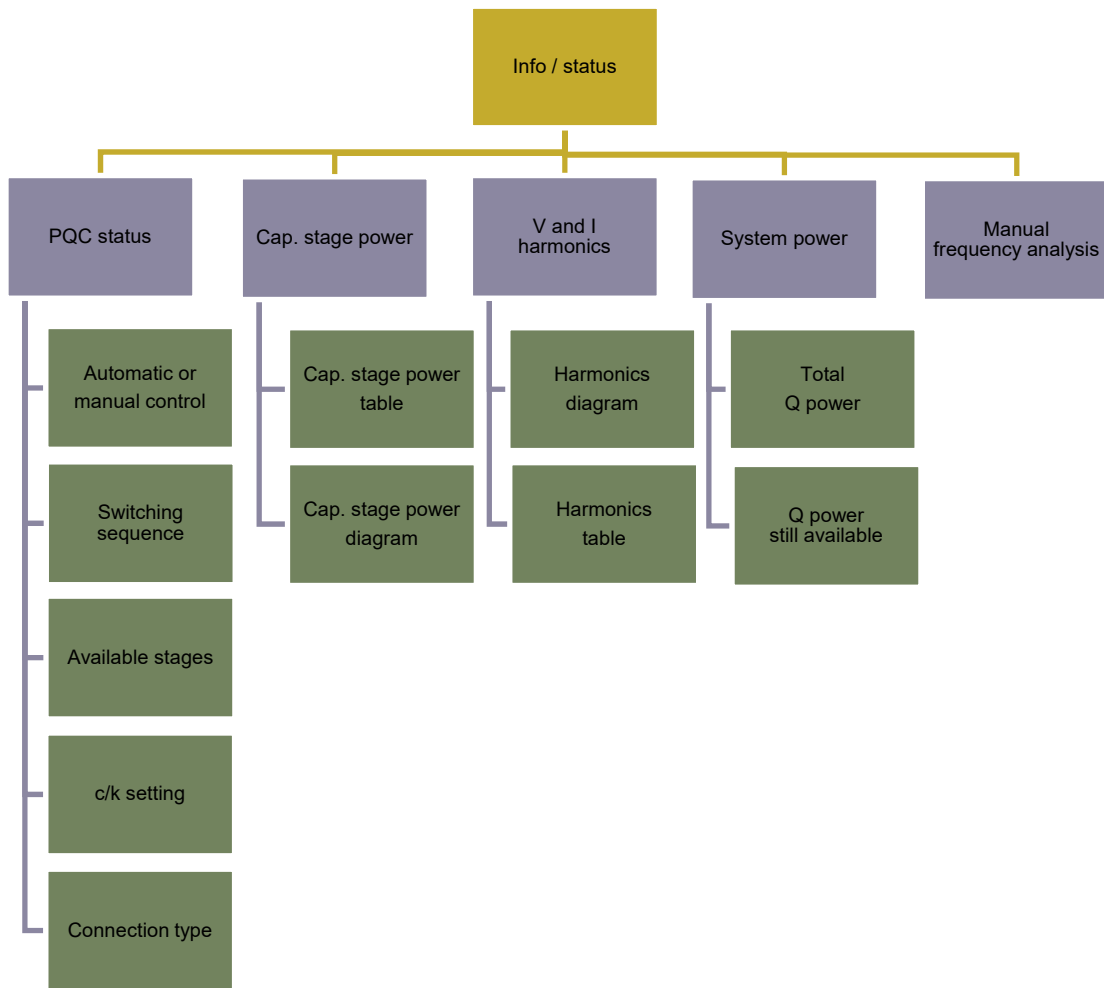

Figure 12 Menu structure 2

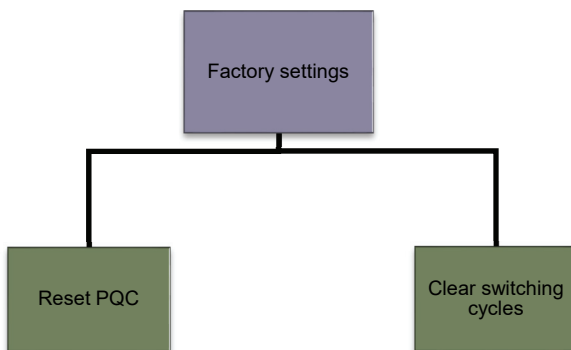





Figure 13 Menu structure 3

## 8 Main menu

The following submenus can be selected from the main menu:

- PQC overview
- Control diagram
- Manual control (password protected)
- Settings (password protected)
- Info / status
- Initial start-up (password protected)
- About PQC...

Key					
Action	PQC overview	Select	Select	Open submenu	-

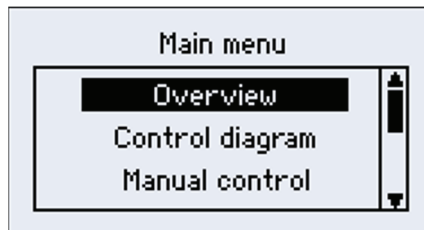

Figure 14 Main menu 1/3

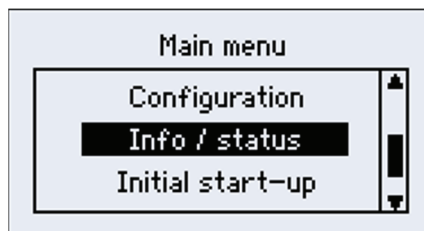







Figure 15 Main menu 2/3



Figure 16 Main menu 3/3

## 8.1 PQC INITIAL START-UP

Key					
Action	Back to main menu	Select language de, en, fr	Select language de, en, fr	Confirm language and return to parameter selection	-

### 8.1.1 Language selection on start-up

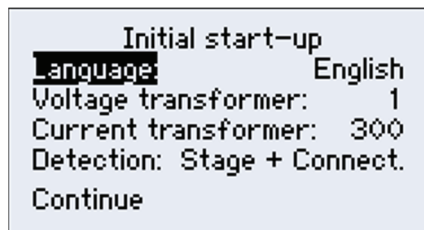

Figure 17 Changing the working language

When the PQC is commissioned, the following parameters can be changed:

- **Language** → German, English (factory default setting), French
- **Voltage transformer** → Range 1 to 300
- **Current transformer** → Range 1 to 7000
- **Detection** → Stage + Connection, Stage, Connection or Manual

Stage + Connection

The PQC carries out the automatic stage and connection identification procedure (see Figure 18 on page 39).

Stage

The PQC carries out the automatic stage identification procedure.  
The connection must be set manually (see Figures 21 and 22 on page 39).

Connection

The PQC carries out the automatic connection identification procedure.  
The parameters for stage detection must be set manually (see Figures 19 and 20 on page 39).

Manual

All parameters for connection and stage identification must be set manually (see Figures 23 and 24 on page 39).

Key					
Action	Back to main menu	Select parameter +	Select parameter -	Confirm	-

All start-up variants and their submenus

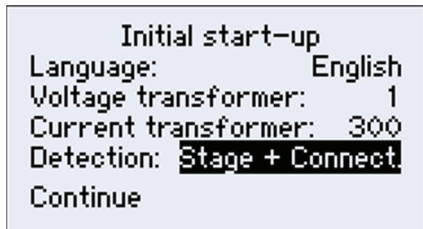

Figure 18 Identification: Stage + Connection

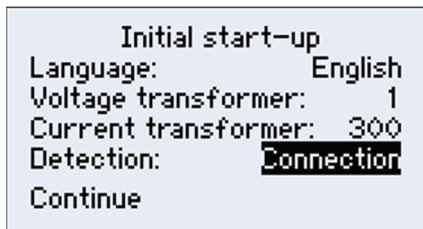

Figure 19 Identification: Connection

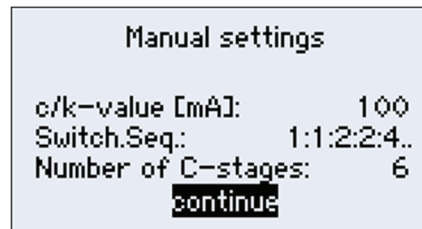

Figure 20 Identification: Connection submenu

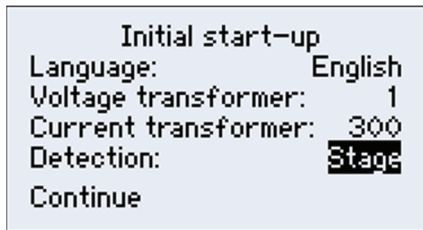

Figure 21 Identification: Stage

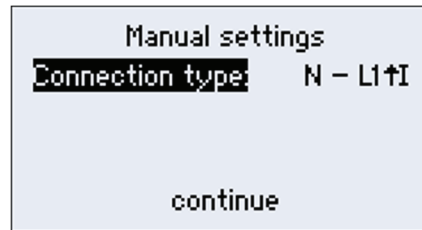

Figure 22 Identification: Stage submenu

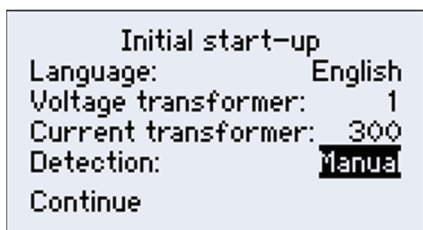

Figure 23 Identification: Manual

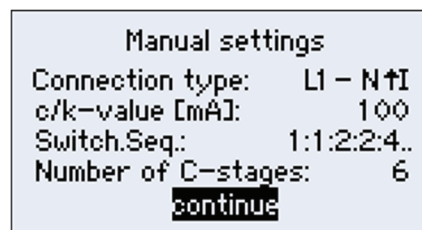

Figure 24 Identification: Manual submenu

The types of connection shown in Figures 22 and 24 correspond to the second column in Table 1 (current transformer in L1 path, installed in the forward direction).



## 8.1.2 Start-up

In the first step, the type of connection is determined with the help of the phase angle.

In the second step, the connected capacitor stages are identified.

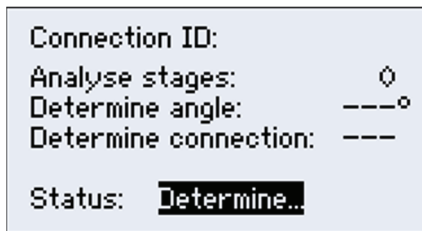

Figure 25 Connection identification started

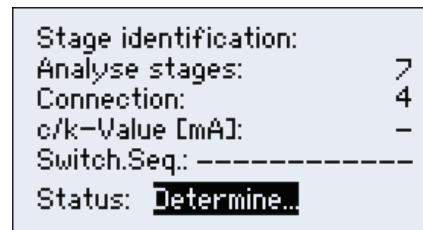

Figure 26 Capacitor stage identification started

Once the capacitor stage identification procedure is completed, the results are indicated. Pressing the Enter key then displays the PQC overview screen.

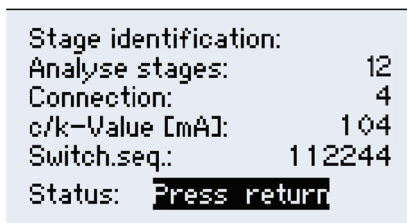







Figure 27 Start-up completed

If the ESC key is pressed to **cancel** the start-up procedure, or if the procedure could not be successfully completed, this is displayed with an error message. In this state, the PQC *is not able to control correctly*. The initial start-up procedure (automatic or manual) must be started afresh.

## 8.2 PQC OVERVIEW

In instrument types with 3-phase measurement, the phase marked with an asterisk \* is the one that the PQC is using for control (see Figure 29 on page 42). Once the automatic commissioning procedure has been completed, the PQC overview screen appears. Pressing the ESC key displays the main menu again. In instrument versions with only single-phase measurement, L1 is always shown as the phase that the PQC is using for control, regardless of which phase the current is actually being measured in (see Figure 28 and Figure 30 on page 42).

Key					
Action	Back to main menu	-	-	Display each screen in turn (preselected control phase)	-

## 8.2.1 Displayed parameters

- $\cos \varphi$  → Display of the momentary value of  $\cos \varphi$
- $V_{\Delta}/V$  →  $V_{\Delta}$  phase voltage / V phase-to-neutral voltage
- P → Display of the momentary active power
- Q → Display of the momentary reactive power  
(capacitive reactive power shown with a minus sign)
- I → Display of the momentary current
- $\Sigma$  → Sum of all 3 phases (L1, L2 and L3)  
(if single-phase PQC, theoretical sum assuming symmetrical loading)
- Regeneration → A negative value of the active power indicates regeneration
- Alarm → Check box for detected alarm condition

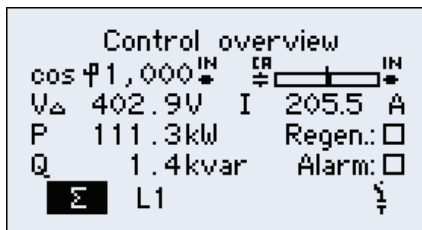

Figure 28 PQC overview L1 (1-phase)

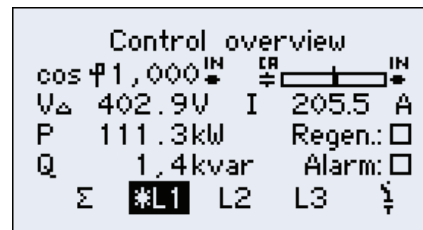

Figure 29 PQC overview L1 (3-phase)

The capacitor stages status overview screen shows the momentary status of all stages.

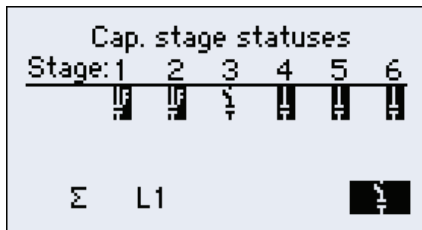

Figure 30 Capacitor stage statuses (1-phase, 6 stages)

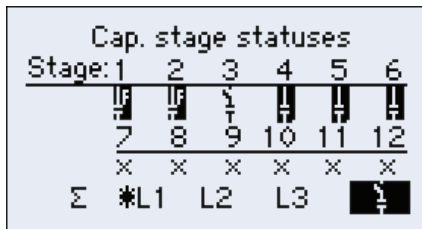

Figure 31 Capacitor stage statuses (3-phase, 12 stages)

Description of Figure 30, capacitor stage statuses (1-phase, 6 stages)

**Stages 1 and 2** → Permanently switched-in fixed capacitor stages

**Stage 3** → This stage is functional but switched out

**Stages 4 to 6** → These stages are functional and switched in

Description of Figure 31, capacitor stage statuses (3-phase, 12 stages)

**Stages 1 and 2** → Permanently switched-in fixed capacitor stages

**Stages 3 and 6** → These stages are functional but switched out

**Stages 4 and 5** → These stages are functional and switched in





**Stages 7 to 12** → Zero stages

### 8.3 CONTROL DIAGRAM

The control diagram shows the currently selected control characteristic curve (active control profile) and provides visualization of the momentary operating point.

#### 8.3.1 Scale

One scale division on the y-axis represents  $\frac{2}{3} \times$  smallest capacitor stage.

Key					
Action	Back to main menu	Zoom +	Zoom -		Additional info

Zoom +	Zoom in on control diagram
Zoom -	Zoom out of control diagram
Additional info	The following parameters are displayed in a separate dialogue: target $\cos \varphi$ , limitation $L$ , parallel shift $PS$ and zoom factor

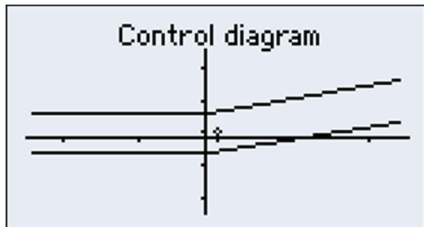

Figure 32 Control diagram

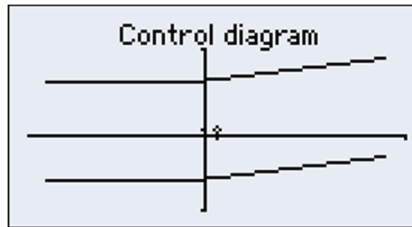

Figure 33 Control diagram with additional information

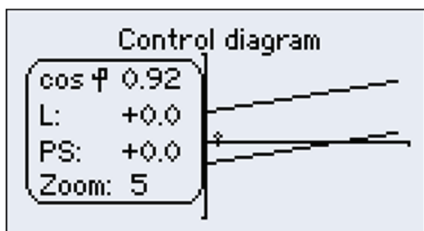



Figure 34 Zoomed in on control diagram

## 8.4 MANUAL CONTROL

	<p><b>CAUTION!</b></p> <p>Switching in capacitor stages manually can result in overcorrection of the system. This can cause other problems, such as resonance-induced overvoltage in the supply network and/or damage to the capacitor stages.</p> <p>The supply network from which the capacitor stages controlled by the PQC are operated must be monitored for resonant conditions and overvoltage whenever stages are switched in manually.</p> <p>This measure will avoid damage to the capacitor stages or to loads connected to the supply network concerned.</p>
---	--

When **Manual control** is selected in the main menu, the following submenu appears.

- **ΔQ power** → Corrective power still lacking to achieve target  $\cos \phi$ 
  - Capacitive corrective power lacking is shown as positive.
  - Inductive corrective power lacking is shown as negative.
  
- **Available Q power** → Capacitor power still available for switching in

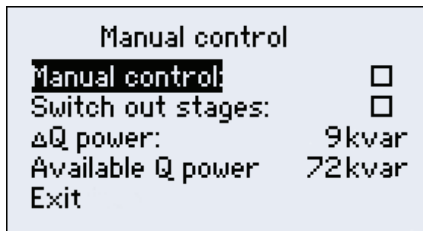







Figure 35 Manual control

Key					
Action	-	Select	Select	Set/Select	-

- **Manual control:** → When this function is enabled, selecting **Continue** then displays the **Stages** submenu.
- **Switch out stages:** → This function switches all switched-in capacitor stages out again.

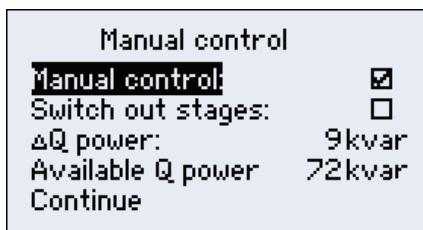

Figure 36 Manual control enabled

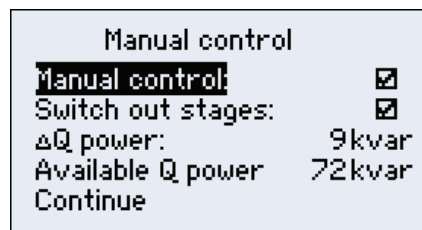

Figure 37 Manual control: Switch out stages

## 8.4.1 Stages menu

Manual control			
No.	Stat.	Q [var]	Swit.cyc.
1	OFF	13,68k	582
2	OFF	14,31k	564
3	OFF	14,31k	546

This menu shows the numbers of the stages (1–12) plus the status (ON/OFF), capacitive power (determined automatically or set manually) and the number of switching cycles of the selected stage.

Figure 38 Manual control: Stages menu

Key					
Action	Return to Manual control dialogue	Select stage	Select stage	Switch stage IN or OUT	-

No.	Stat. (Status)	Q (var)	Switching cycles
No. of the stage [1–12]	ON / OFF / [x seconds]	Available stage corrective power [var]	Number of stage switching cycles
	ON → Switches stage in manually OFF → Switches stage out manually [x seconds] → Time remaining until the capacitor stage can be switched in again (discharge time)	This is the 3-phase stage corrective power.	

Manual control			
No.	Stat.	Q [var]	Swit.cyc.
1	ON	13,68k	582
2	OFF	14,31k	564
3	OFF	14,31k	546

Figure 39 Example of a selected stage

When a stage is switched out again, this is done immediately. Before this stage can be switched in again, it is necessary to wait until the capacitor's set discharge time has elapsed. A countdown of the remaining discharge time is displayed in the Status column. Not until this time has elapsed can the stage be switched in again. If it is attempted to switch in the stage before the countdown is finished, the message 'Not possible' is displayed (see Figure 40). The stage is then not switched in automatically after the discharge time has elapsed.

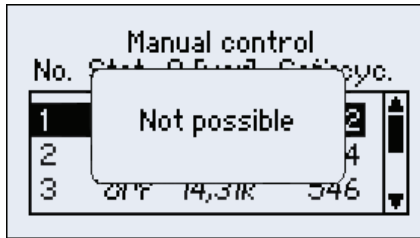

Figure 40 Message on failed attempt to switch in a stage

## 8.5 SETTINGS

The Settings menu is selected from the main menu. It offers the following submenus:

- **Control profiles** → 5 profiles, see Section 8.5.1.
- **General** → Capacitor stages, Set limits, Alarm management, Extensions
- **Factory settings** → PQC reset, Clear switching cycles

Key	ESC	↑	↓	↻	i
Action	Back to main menu	Select	Select	Open submenu	-



Figure 41 Settings

### 8.5.1 Settable control profiles

Five control profiles can be individually selected and edited. The instrument is supplied with the following factory settings:

Profile	1	2	3	4	5
Target cos $\varphi$	0.92 ind	1.0	1.0	0.92 ind	0.96 cap
Parallel shift	-1.0	0.0	+1.0	-1.0	-1.0
Limitation	+1.0	off	off	off	off
Switching delay	45 seconds	45 seconds	45 seconds	45 seconds	45 seconds
Phase	L1	L1	L1	L1	L1

### 8.5.2 Typical control profile applications

- **Profile 1** → Describes the ideal control characteristic curve for all **consumer networks** where an **inductive** cos  $\varphi$  is called for.
- **Profile 2** → Suitable for **consumer networks** where an average cos  $\varphi$  =1 is to be achieved.

- **Profile 3** → Suitable for **consumer networks** where  $\cos \varphi$  is close to 1 but overcorrection is to be avoided.
- **Profile 4** → Suitable for **consumer networks**, as described in Profile 1, but which have their own generating facilities (e.g. CHP units) with permanent or frequent **feed-in** (regeneration) to the power supply network.
- **Profile 5** → Suitable for **generating networks**, such as hydropower or wind turbines, where a capacitive  $\cos \varphi$  is called for.





Figure 42 Control profiles

Key					
Action	Control setting	Select profile	Select profile	Set profile	-

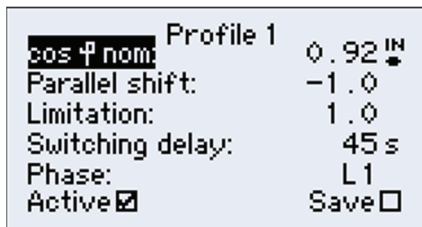

Figure 43 Control profile parameters

Key					
Action	Profile selection (Save Yes/No)	Select parameter	Select parameter	Parameter selection Back to parameter selection	-

Key					
Action	Profile selection (Save Yes/No)	Increase value +	Decrease value -	Back to parameter selection	-

<b>Target cos <math>\varphi</math></b>	→ 0.90 capacitive to 0.80 inductive (in increments of 0.01)
<b>Parallel shift</b>	→ 2.0 to +4.0 (in increments of 0.5)
<b>Limitation</b>	→ 2.0 to +2.0 (in increments of 0.5) and OFF
<b>Switching delay</b>	→ 5 to 500 s (in 1 s increments)
<b>Phase</b>	→ L1, L2 or L3: select control phase
<b>Active</b>	→ Activate control profile (only <u>one</u> profile can be active)
<b>Save</b>	→ Save changes in control profile

#### 8.5.2.1 Setting target cos $\varphi$

The desired value of target cos  $\varphi$  can be set from 0.80 inductive to 0.90 capacitive in increments of 0.01. The mode of operation of this adjustment can be seen in Figures 44 and 45.

If the system operates within the band range shown, no switching operations will be activated. However, if the system operates outside the band range, the PQC will try to return to within the band range with the minimum number of switching cycles.

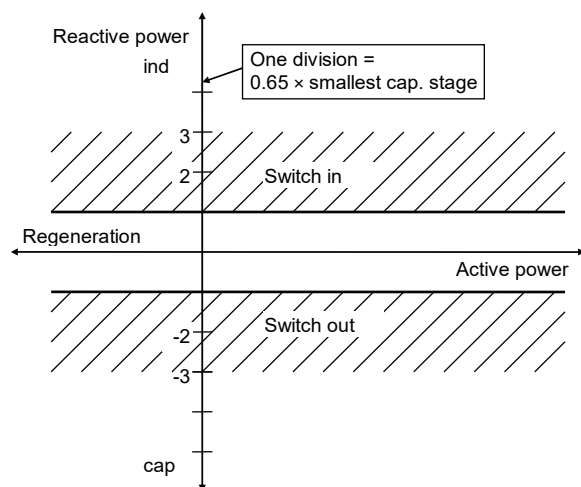

Figure 44 Control response after setting target  $\cos \varphi = 1$ , limitation = 0, parallel shift = 0

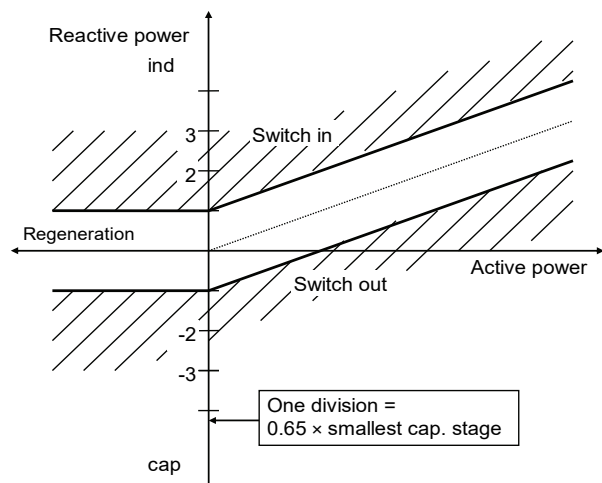

Figure 45 Control response after setting target  $\cos \varphi = 0.92$ , limitation = 0, parallel shift = 0

In Figure 45, the action of the PQC during regeneration (feed-in to the supply network) can be seen. The 'kink' in the band (characteristic line) is not reflected in the regeneration quadrants. Instead, the band extends laterally from the point where it crosses the reactive power axis (y-axis).

By shifting the band into the capacitive range (see Figure 47), inductive reactive power during regeneration can be virtually avoided.

When a capacitive target  $\cos \varphi$  is set, the control band is a mirror image from the power draw side to the regeneration side (see Figure 50).

### 8.5.2.2 Parallel shift

This setting causes a parallel shift of the band range shown above through the set value. It will shift in the inductive direction if the plus sign is used, and in the capacitive direction if the minus sign is used.

The values -2 to +4 can be set in increments of 0.5. The effects are illustrated by the two examples in Figures 46 and 47.

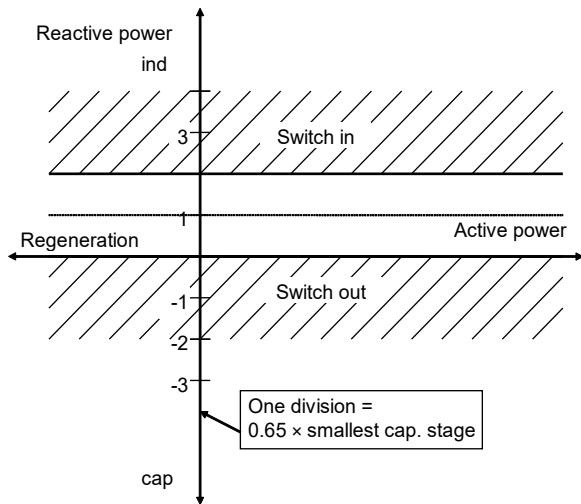

Figure 46 Control response after setting target  $\cos \varphi = 1$ , limitation = 0, parallel shift = +1.0

The set target  $\cos \varphi$  is therefore the upper limit of the control band. Overcompensation is avoided.

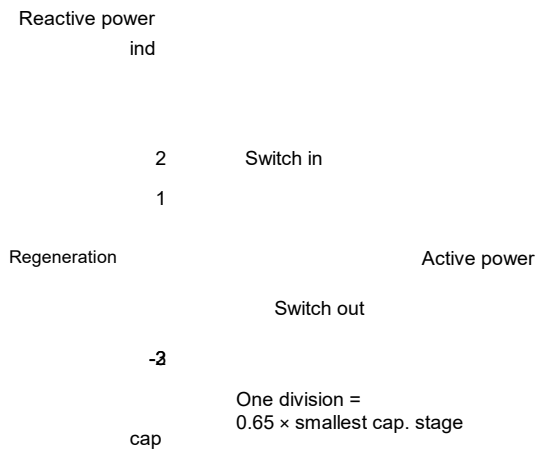

Figure 47 Control response after setting target  $\cos \varphi = 0.92$  ind, limitation = OFF, parallel shift = -1.0

Here the set target  $\cos \varphi$  constitutes the lower (more inductive) limit of the control band. When regeneration occurs, the lower (more inductive) limit constitutes a target  $\cos \varphi$  of 1. This means that no inductive reactive power can result during feed-in operation.

***(This is the recommended setting when operating induction generators in parallel with the supply network.)***

### 8.5.2.3 Limitation L

This setting gives new possibilities that could not be attained previously due to conflicting requirements. The range of values for  $L$  are -2 to +2 in increments of 0.5, including the setting OFF. Setting  $L$  at 1 and the target power factor at 1.00 has the same effect as the parallel shift described above. If the target  $\cos \varphi$  is not set at 1, a kink results in the control curve, as shown in the example in Figure 48. The limitation forms an absolute boundary beyond which the reactive power may not go.

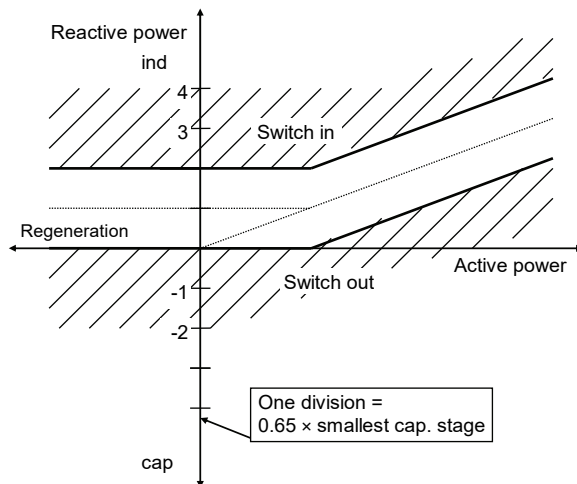

Figure 48 Control response after setting target  $\cos \varphi = 0.92$  ind, limitation = +1.0

This setting has the following effects:

- The target power factor is attained, on average, in the *upper power range*.
- Overcorrection (capacitive, usually disruptive) is avoided in the *low load range*.

An effective combination of *parallel shift* and *limitation* is illustrated in Figure 49.

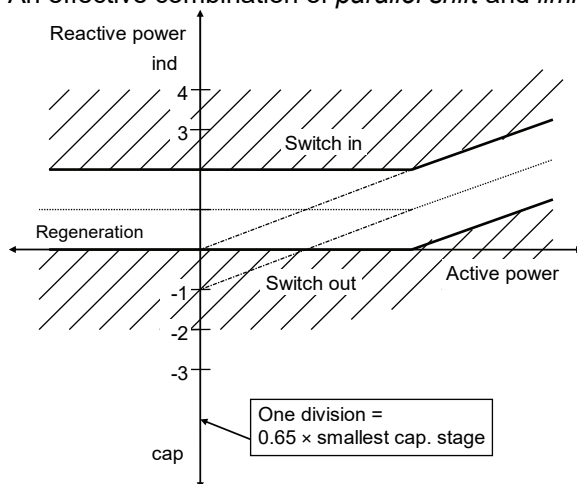

Figure 49 Control response after setting target  $\cos \varphi = 0.92$  ind, limitation = +1.0, parallel shift = -1.0

This example illustrates:

- In the 'upper' power range, the set  $\cos \varphi$  is specified as the lower (more inductive) limit value.
- Overcorrection is avoided in the low load range.

For the sake of completeness, the following figure shows the characteristics of the control band when set for a capacitive target  $\cos \varphi$ . In this case, the control range does not extend laterally at the reactive power axis into the regeneration quadrants, but is mirrored from the power draw side into the regeneration side.

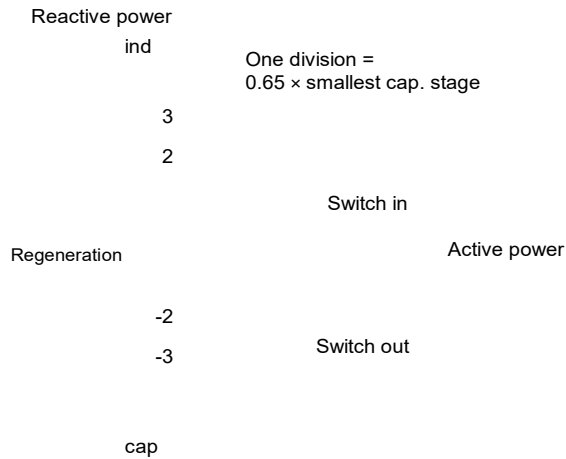

Figure 50 Control response after setting target  $\cos \phi = 0.95$  cap, limitation = -1.0, parallel shift = 0

### 8.5.2.4 Switching delay

The switching delay, i.e. the time between one switching action and the next for the same capacitor stage, can be set between the values of 5 and 500 seconds in 5-second increments. When a stage is to be switched in or out, the PQC waits for this switching delay to elapse before switching takes place. If more stages are required, the switching time delay is shortened in accordance with the number of stages concerned:

e.g. 2 stages required = switching delay time  $\div$  2, or 3 stages required = switching delay time  $\div$  3.

In order to keep the wear of the contacts to a minimum, the switching delay time should be set to less than 45 seconds only in exceptional cases. The discharge time, which ensures that the capacitors are fully discharged before they are switched on again, takes precedence over, i.e. overrides, the switching delay.

### 8.5.2.5 Selecting the control phase

The control profiles menu also includes the **Phase** setting. This is used to select the phase used by the PQC for control purposes (can only be edited on 3-phase PQCs).

Any one of the three phases L1, L2 and L3 may be selected (with single-phase PQCs, the phase L1 is a fixed setting).

On the PQC overview screen, the phase marked with an asterisk \* on its left is the one selected for the PQC to use for control purposes.

*Note:* with single-phase PQCs, the connected phase is always the one used for control purposes.

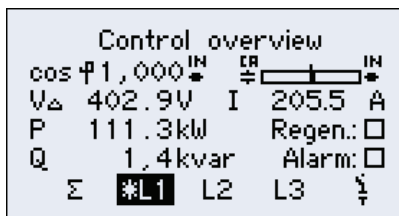

Figure 51 Phase L1 is the control phase

### 8.5.3 General settings

Selecting Settings in the main menu enables the General menu to be displayed. The following submenus can then be selected:

- **Capacitor stages** → Cyclic switching, discharge time, fixed capacitor stages, choke factor, zero stage limit, nominal voltage
- **Set limits** → Settings for the limits of parameters
- **Alarm management** → Alarm relay, PQC trip and display alarms
- **Extensions** → A submenu is provided for every optional extension.



Key					
Action	Back to Settings	Select	Select	Open submenu	-



Figure 52 General settings menu

#### 8.5.3.1 Capacitor stages menu

- **Cyclic switching** → ON / OFF (ON is recommended). The purpose of cyclic switching is to ensure that all capacitor stages of the same power rating are switched in equally frequently.
- **Discharge time** → 5–900 s (1 s increments) capacitor stage discharge time. The discharge time must be at least as long as the longest discharge time of the capacitors in use.
- **Fixed stages** → Capacitor stages permanently switched in, not under PQC control
- **Choke factor (detuning)** → Choke of the power factor correction system. (A value must be set for correct computation. If the system is not detuned, 0% must be entered).
- **Zero stage (dud) limit** → Set limit for classifying a capacitor stage as zero. It is that percentage of the most recently calibrated corrective power below which the stage is excluded from the power factor control process.

Example: Zero stage limit set at 85%

At initial start-up (calibration), the corrective power of stage 1 was determined as 50 kvar. Later, a capacitor of stage 1 becomes defective, so that 12.5 kvar are now lacking, and the stage has a corrective power of only 37.5 kvar.

- This corresponds to a stage power loss of:

$$\left(1 - \frac{37.5 \text{ kvar}}{50 \text{ kvar}}\right) * 100 = 25\%$$

- The residual corrective power of the stage as a percentage of its power on start-up is thus:  $100\% - \text{power loss} = 75\%$   
Result: The alarm is given, since the residual corrective power as a percentage is less than the set limit of 85%.

- **Nominal voltage** → The nominal supply voltage

Key					
Action	Back to General	Select parameter	Select parameter	Edit parameter	-

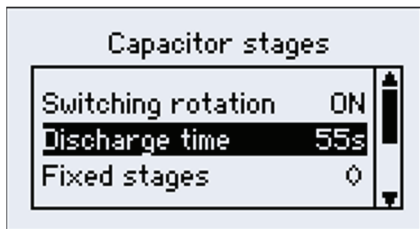

Figure 53 Capacitor stages

Key					
Action	Capacitor stage menu	Change parameter	Change parameter	Save parameter	-

### 8.5.3.2 Setting alarm limits

The following parameters can be adjusted in the **Set limits** menu:

- Switching cycle counter → 10k–500k (in increments of 1k), default setting = 80k
- THDI → 5%–500% (in increments of 1%)
- V/I harmonics → 0%–100% (in increments of 0.01%)
- Overcurrent → 1.00–2.00 (in increments of 0.01)
- Voltage blackout (sag) → 50%–93% (in increments of 1%)
- Number of ¼ cycles → 2–4 (in increments of 1)
- Detecting phase → L1, L2, L3

Key					
Action	Back to Settings	Select limit	Select limit	Edit limit	-

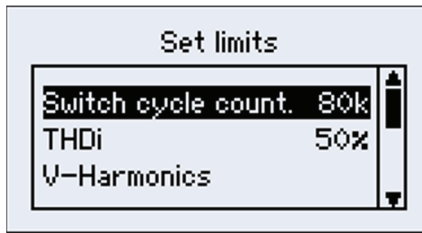

Figure 54 Set limits 1/2

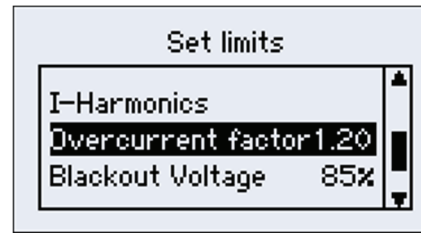

Figure 55 Set limits 2/2

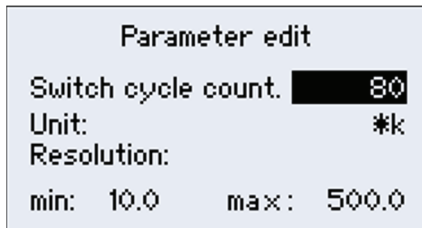

Figure 56 Change set limit for switching cycle counter

#### 1.1.1.1.1 *Overcurrent*

Overcurrent is the theoretically determined ratio of the root-mean-square current to the fundamental current in the capacitor ( $I_{rms}/I_{50Hz/60Hz}$ ). It therefore indicates how large the proportion of harmonic currents is in comparison with the fundamental current.

The choke factor  $p$  of the power factor correction system is also taken into account in this theoretical computation.

→ The overcurrent in the capacitor can only be computed accurately if the system's choke factor is entered correctly. If the system is not detuned, the value  $p = 0\%$  should be entered.

#### 2.1.1.1.1 *Detection of voltage blackout (sag)*

The detection of voltage sag is a function designed to protect the capacitors and their contactors against power cuts that are short enough to make the capacitor contactors open and immediately close again.

This function has the following setting options:

Detecting phase: The phase to which the operating coil of the capacitor contactor is connected

Number of  $\frac{1}{4}$  cycles: Time before an undervoltage alarm is given  
Adjustable from a  $\frac{1}{2}$  wave to a full wave of the sinusoidal voltage signal in increments of  $\frac{1}{4}$  waves

Example:

In a 50 Hz supply,  $\frac{1}{2}$  wave = 10 ms,  $\frac{3}{4}$  wave = 15 ms, full wave (4/4) = 20 ms

Voltage blackout (sag) in % (100% being the nominal supply voltage): This is the root-mean-square voltage setting at which the voltage sag detection function is to react.

Presettings: Half-wave detection, alarm given if voltage at L1 drops below 85% of the nominal voltage.

Settings:

- Voltage blackout (sag): 85 %
- Number of  $\frac{1}{4}$  cycles:  $\frac{1}{2}$  wave
- Detecting phase: L1

For this very important function to operate effectively, it is vitally important that the phase selected for the instrument power supply to the switching outputs is the same one selected for the voltage measurement.



### 8.5.3.3 Alarm management

The following alarm options can be selected in this submenu:

- Alarm relay
- PQC trip
- Display alarm

Key	ESC	↑	↓	↔	i
Action	Back to General	Select alarm option	Select alarm option	Open alarm option setting submenu	-



Figure 57 Alarm management

Setting in Alarm relay, PQC trip and Display alarm submenu:

Key	ESC	↑	↓	↔	i
Action	Alarm management	Select alarm source	Select alarm source	Set ON/OFF (saved immediately)	-

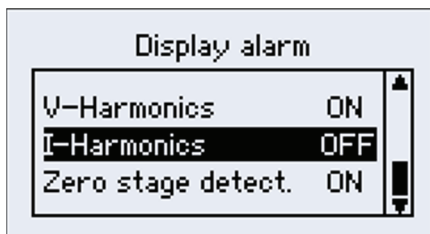







Figure 58 Alarm management; here the Display alarm option

The following alarms / actions can be enabled / disabled in all submenus of the **Alarm management** menu:

- **cos φ alarm**
- **Undervoltage**
- **Undercurrent**
- **Overcurrent**
- **THDI**
- **Switching cycles**
- **V harmonics (harmonic voltage)**
- **I harmonics (harmonic current)**
- **Zero stage (dud) detected**
- **Voltage blackout (sag) detected**

### 8.5.3.4 Optional Modbus RTU interface

Key					
Action	Back to main menu	Select parameter	Select parameter	Edit parameter	-

The Modbus setting menu is navigated to as follows: **Settings / General / Extensions / Modbus**

These settings are only possible with PQC versions xxxxx-2x.

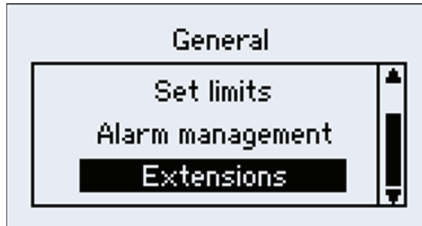

Figure 59 Extensions menu

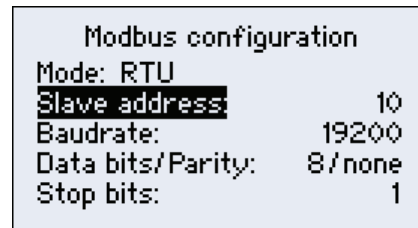

Figure 60 Modbus configuration

The following parameters can be set in the **Modbus configuration** menu:

- **Bus address** → The instrument is accessed at the set bus address
- **Baud rate** → 1200, 2400, 4800, 9600, 19200, 38400, 57600, 115200
- **Data bits** → 5 to 8
- **Stop bits** → 1 or 2
- **Parity** → even, odd or none

Further details are given in the Modbus specification.

### 8.5.3.5 Factory settings

- Reset PQC → Reset the PQC to its factory settings (This does not affect the switching cycle counters.)
- Clear switching cycle counter → Reset switching cycle counters for all stages to zero (singly or individually, service password necessary; see section 8.5.3.6).

*Note:*

**A switching cycle counter may only be reset after the corresponding contactor has been replaced!**











Key					
Action	Back to Settings / General	Select reset type	Select reset type	Select reset type	-



Figure 61 Factory default settings

Key					
Action	Back to factory default settings	Up	Down	Confirm action	-

### 8.5.3.6 Password protection

The PQC uses a password to prevent sensitive menu items being accessed by unauthorized persons. This is entered by means of the Up and Down keys.

Protected menu items:

- Settings Security level 1
- Manual control Security level 1
- Initial start-up Security level 1
- Reset switching cycle counters Security level 2

Security level 1:

Password: last four digits of the serial number (see label on PQC or Section 8.7)  
 Example: Serial number 11024 → Password 1024

Security level 2:

Password: 3725



Figure 62 Password prompt

The password prompt is displayed as soon as one of the items in the main menu (see Section 8) is selected.

The Up and Down keys are used to adjust each digit, which is then confirmed with the Return/Enter key. Once the 4th digit has been confirmed with this key, the menus at the security level concerned become accessible for one hour.

## 8.6 INFO / STATUS

- **PQC status** → Overview of all required setting parameters
- **Total cap. power** → Sum of the reactive power Q plus that still available
- **Cap. stages table** → Table with status of individual stages
- **Cap. stages diagram** → Overview of the stage power ratings in % for start-up calibration
- **V/I harmonics diag./table** → Analysis up to 19th voltage and current harmonics in diagram and table format
- **Switching cycle diagram** → Graphical overview of stages switching cycle counter
- **Man. freq. analysis** → Analysis from 10 to 2500 Hz, manually selectable

Key	ESC	↑	↓	↔	i
Action	Back to main menu	Select submenu	Select submenu	Open submenu	-

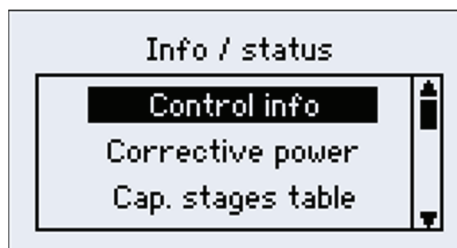

Figure 63 Info / status 1/3

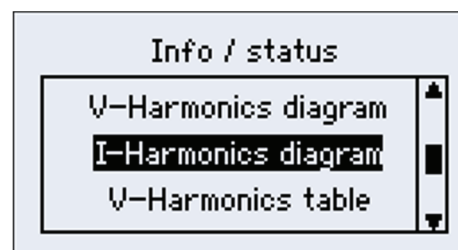

Figure 64 Info / status 2/3

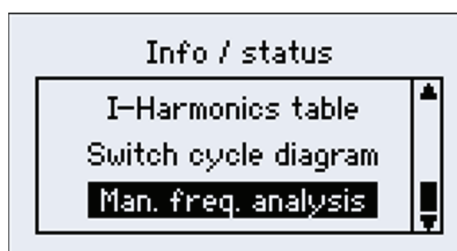

Figure 65 Info / status 3/3

## 8.6.1 PQC status

**PQC status** → Overview of all necessary setting parameters

The following parameters are displayed in the PQC status menu:

- PQC status → Automatic or manual control mode
- Switching sequence → Display of the capacitor stages detected.  
The relative values (switching sequence) can be distributed over the available stages as desired. The largest permitted relative value is 16, the smallest 0.
- Available stages → Number of capacitor stages detected
- c/k setting [mA] → The response current is determined from the smallest capacitor stage detected.
- Type of connection → See Table 1, Connection types for current transformers in L1, L2 and L3.

Info / status	
Control status:	Auto control
Switch.Seq.:	112244
Available stages:	6
c/k-value [mA]	90
Connection type:	6

Figure 66 PQC status overview

## 8.6.2 Corrective power

Corrective power	
$\Sigma$ Q-power:	377,96 kvar
Available Q-Power:	350,96 kvar
Overcurrent:	1,772

Figure 67 Total corrective power Q

- $\Sigma$  Q power → The sum total corrective power of all connected 3-phase capacitor stages
- Available Q power → 3-phase corrective power still available for switching in
- Overcurrent → The overcurrent ratio  $I_{rms}/I_{50Hz/60Hz}$  is displayed.

Overcurrent is the theoretically determined ratio of the root-mean-square current to the fundamental current in the capacitor. The choke factor  $p$  of the power factor correction system is also taken into account in this theoretical computation.

- The overcurrent in the capacitor can only be computed accurately if the system's choke factor is entered correctly.

### 8.6.3 Capacitor stages table

Cap. stages table			
Nr.	Stat.	Q [var]	Swit.cyc.
1	OFF	13,68k	582
2	OFF	14,31k	564
3	OFF	14,31k	546

Figure 68 Capacitor stages table

### 8.6.4 Capacitor stages rating diagram

The capacitor stages rating diagram shows the momentary corrective power of the capacitor stages as a percentage. After the instrument has been started up, this graphic shows every detected stage as 100%. With time, however, capacitor wear causes this corrective power to fall. When it falls below a set level, the PQC gives an alarm.

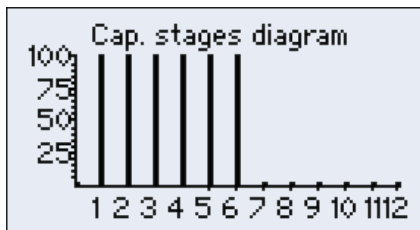

Figure 69 Diagram showing all stages at 100%

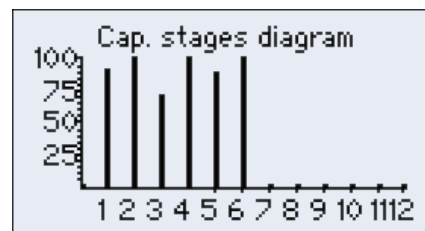

Figure 70 Diagram showing corrective power of all stages

### 8.6.5 Switch cycle diagram

This diagram shows the switching cycle counters for all the stages as a column chart. 100% on the y-axis represents the set limit for the number of switching cycles counted.

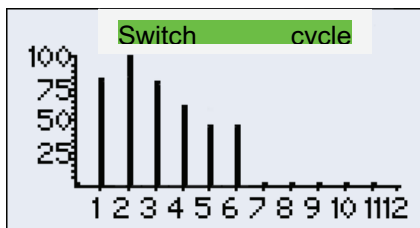







Figure 71 Switch cycle diagram

## 8.6.6 Voltage and current harmonics diagram

Key					
Action	Back to Info / status menu	Zoom in	Zoom out	Switch between harmonics 1–12 and 8–19	Additional info

100% corresponds to the fundamental wave at 50/60 Hz. One scale division on the y-axis represents 5%.

The harmonics are displayed graphically:

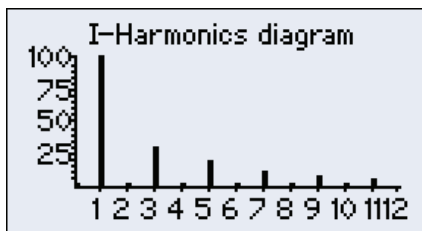

Figure 72 Current harmonics diagram, y-axis 100%

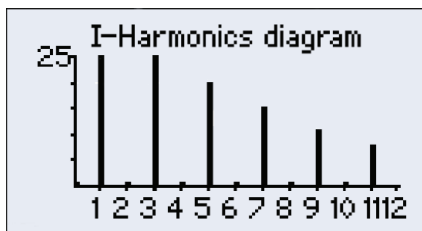

Figure 73 Current harmonics zoomed in, y-axis 25%





## 8.6.7 Voltage and current harmonics table

This menu item displays a table showing all the harmonics as percentages of the fundamental.

V-Harmonics	
Harmonic 1	100,00
Harmonic 2	0,68
Harmonic 3	31,96

Figure 74 Voltage harmonics table

## 8.6.8 Manual frequency analysis

Key					
Action	Back to Info / status menu	Frequency +10 Hz	Frequency -10 Hz	Select phase	-

- **Phase** → Measurement at  $L_x$  [ $1 \leq x \leq 3$ ]
- **Frequency** → 10–2500 Hz in increments of 10 Hz
- **V(f)** → Magnitude of the voltage at the given frequency as a percentage of the fundamental voltage  $V_1$  ( $f = 50/60$  Hz)
- **I(f)** → Magnitude of the current at the given frequency as a percentage of the fundamental current  $I_1$  ( $f = 50/60$  Hz)
- **Angle  $\varphi$**  → Angle between V(f) and I(f) in degrees
- **Angle  $\gamma$**  → Angle between  $V_1$  (fundamental frequency) and I(f) in degrees

Note:  $V_1$  and  $I_1$  are respectively the magnitudes of the voltage and current at the fundamental frequency  $f_1 = 50$  or 60 Hz

Frequency analyse	
Phase:	L1
frequency:	50 Hz
V(f)=	100% (V <sub>g</sub> )
I(f)=	100% (I <sub>g</sub> )
$\varphi$ / $\gamma$	+342 / +0

Figure 75 Manual frequency analysis



## 8.7 ABOUT PQC SUBMENU

This dialogue displays information about the instrument:

- FW:           Firmware version number
- HW           Hardware version number
- PCB          Printed circuit board numbers
- SN           Serial number

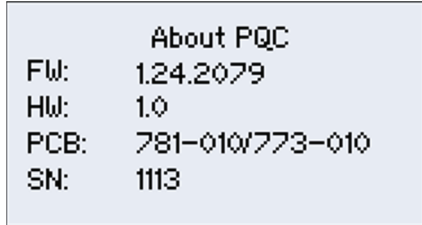

Figure 76      About PQC

## 8.8 FACTORY DEFAULT SETTINGS

Table 4 Factory default settings

Initial start-up	Connection type	0 (L1-N)
	c/k setting	2000 mA
	Switching sequence	1;1;1;1;1;
	Number of capacitor stages	6 or 12 (depending on type)
Settings of control profile 1	cos $\varphi$	0.92 ind
	Parallel shift	-1
	Limitation	1
	Delay time	45 s
	Phase	L1
	Active	Yes
Settings of control profile 2	cos $\varphi$	1.0
	Parallel shift	0
	Limitation	OFF
	Delay time	45 s
	Phase	L1
	Active	No

Settings of control profile 3	cos $\varphi$	1		
	Parallel shift	+1		
	Limitation	OFF		
	Delay time	45 s		
	Phase	L1		
	Active	No		
Settings of control profile 4	cos $\varphi$	0.92 ind		
	Parallel shift	-1		
	Limitation	OFF		
	Delay time	45 s		
	Phase	L1		
	Active	No		
Settings of control profile 5	cos $\varphi$	0.96 cap		
	Parallel shift	-1		
	Limitation	OFF		
	Delay time	45 s		
	Phase	L1		
	Active	No		
Settings -> General → Capacitor stages	Cyclic switching	ON		
	Discharge time	60 s		
	Fixed stages	0		
	Choke factor (detuning)	7%		
	Zero stage (dud) set limit	80%		
	Nominal voltage	400 V		
Settings -> General → Set limits	Switching cycle counters	80000		
	THDI	50%		
	V harmonics	Harmonic	Set limit in %	
		2	2	
	3	100		

		4	1		
		5	6		
		6	100		
		7	5		
		8	0.5		
		9	100		
		10	0.5		
		11	3.5		
		12	100		
		13	3		
		14	0.43		
		15	100		
		16	0.41		
		17	2		
		18	100		
		19	1.76		
		I harmonics		100% (all)	
		Overcurrent ratio		1.2	
		Voltage blackout (sag) limit		85%	
		Number of ¼ cycles		2 (½ wave)	
Detecting phase		L1			
Settings -> General → Alarm management	Alarm relay	Alarm	ON/OFF		
		cos φ alarm	ON		
		Undervoltage	ON		
		Undercurrent	OFF		
		Overcurrent	ON		
		THDI	OFF		
		Switching cycles	ON		
		V harmonics	OFF		
		I harmonics	OFF		
		Zero stage (dud) detection	ON		
		Voltage blackout (sag) detection	ON		

	PQC trip	Alarm	ON/OFF
		cos $\varphi$ alarm	OFF
		Undervoltage	ON
		Undercurrent	ON
		Overcurrent	ON
		THDI	OFF
		Switching cycles	OFF
		V harmonics	OFF
		I harmonics	OFF
		Zero stage (dud) detection	OFF
		Voltage blackout (sag) detection	ON
	Display alarm	Alarm	ON/OFF
		cos $\varphi$ alarm	ON
		Undervoltage	ON
		Undercurrent	ON
		Overcurrent	ON
		THDI	OFF
		Switching cycles	ON
		V harmonics	ON
		I harmonics	OFF
		Zero stage (dud) detection	ON
Voltage blackout (sag) detection	ON		

## 8.9 UPDATE



### DANGER!

The following instructions must be observed to avoid danger to life and limb:

- The update may only be installed by a qualified technician.
- In Germany, it is essential to comply with the regulations of the Social Accident Insurance Institution covering electrical installations. In other countries, the equivalent local regulations must be followed.
- Before beginning the update procedure and plugging in the USB cable required for this, the instrument and its associated cables must be isolated from the power supply.
- The isolated electrical system must be locked out to prevent its being inadvertently switched on again.
- The immediate vicinity must be covered.
- The USB connector may now be plugged into the PQC (not before!).
- The instructions for the update procedure must be followed exactly. For further information please contact Schrack Technik [www.schrack.com](http://www.schrack.com)

When work is carried out in the vicinity of the instrument terminals and connecting cables, there is a risk of live components being touched inadvertently. The working voltage may present a hazard to health or may even be life-threatening.

If the above instructions are followed, the risk of endangering life and limb can be significantly reduced.

The USB port is a service interface provided solely for updating the PQC firmware. Users are not permitted to use this USB port for any other purpose, and therefore must not connect any cable or device to it. When the PQC is in operation, the USB port must not be touched. It is intended for connecting a battery-powered notebook.

A USB cable with a Micro-A or Micro-B male connector is required for the update procedure. The USB port is located underneath the instrument inside the control cabinet. The above safety instructions must be observed before the control cabinet is opened!

Depending on where the instrument is mounted, access to the USB interface port on the PQC may be difficult.

For further information, please contact Schrack Technik [www.schrack.com](http://www.schrack.com)

## 9 Instrument versions

Table 5 Instrument versions

type No.	Version	Number of relay stages	Instrument power supply AUX <sup>2</sup>	Measurement	Option
38-00400	PQC 1202401-0	12 (250 V AC, 3 A, cos $\varphi = 1$ )	100 V -15% to 240 V +10% AC approx. 5 VA <sup>3</sup>	single-phase	-
38-00403	PQC 1202401-01	12 (250 V AC, 3 A, cos $\varphi = 1$ )	"	single-phase	Temp. I/O
38-00404	PQC 1202401-20	12 (250 V AC, 3 A, cos $\varphi = 1$ )	"	single-phase	Modbus RTU
38-00405	PQC 1202401-21	12 (250 V AC, 3 A, cos $\varphi = 1$ )	"	single-phase	Modbus RTU, Temp. I/O
38-00401	PQC 1202403-0	12 (250 V AC, 3 A, cos $\varphi = 1$ )	"	3-phase	-
38-00411	PQC 1202403-01	12 (250 V AC, 3 A, cos $\varphi = 1$ )	"	3-phase	Temp. I/O
38-00412	PQC 1202403-20	12 (250 V AC, 3 A, cos $\varphi = 1$ )	"	3-phase	Modbus RTU
38-00413	PQC 1202403-21	12 (250 V AC, 3 A, cos $\varphi = 1$ )	"	3-phase	Modbus RTU, Temp. I/O
38-00402	PQC 0602401-0	6 (250 V AC, 3 A, cos $\varphi = 1$ )	"	single-phase	-
38-00416	PQC 0602401-01	6 (250 V AC, 3 A, cos $\varphi = 1$ )	"	single-phase	Temp. I/O
38-00417	PQC 0602401-20	6 (250V AC, 3 A, cos $\varphi = 1$ )	"	single-phase	Modbus RTU
38-00418	PQC 0602401-21	6 (250V AC, 3 A, cos $\varphi = 1$ )	"	single-phase	Modbus RTU, Temp. I/O

<sup>2</sup> AUX as in the connection diagrams in Section 5.7, Connection diagrams of all PQC instrument types.

<sup>3</sup> 85 V AC - 267 V AC (absolute limits, networks 100 V AC - 240 V AC), frequency 45 - 65 Hz or 100 V DC - 377 V DC (absolute limits)

38-00406	<b>PQC 1204801-0</b>	<b>12</b> <b>(250 V AC,</b> <b>3 A, cos φ = 1)</b>	<b>100 V –10%</b> <b>to</b> <b>480 V +10% AC</b> <b>approx. 5 VA<sup>4</sup></b>	<b>single-</b> <b>phase</b>	-
38-00421	PQC 1204801-01	12 (250 V AC, 3 A, cos φ = 1)	"	single- phase	Temp. I/O
38-00422	PQC 1204801-20	12 (250 V AC, 3 A, cos φ = 1)	"	single- phase	Modbus RTU
38-00423	PQC 1204801-21	12 (250 V AC, 3 A, cos φ = 1)	"	single- phase	Modbus RTU, Temp. I/O
38-00407	PQC 1204803-0	12 (250 V AC, 3 A, cos φ = 1)	"	3-phase	-
38-00426	PQC 1204803-01	12 (250 V AC, 3 A, cos φ = 1)	"	3-phase	Temp. I/O
38-00427	PQC 1204803-20	12 (250 V AC, 3 A, cos φ = 1)	"	3-phase	Modbus RTU
38-00428	PQC 1204803-21	12 (250 V AC, 3 A, cos φ = 1)	"	3-phase	Modbus RTU, Temp. I/O
38-00410	PQC 0614801-0	6 (440 V AC, 3 A, cos φ=1)	"	single- phase	-
38-00431	PQC 0614801-01	6 (440 V AC, 3 A, cos φ=1)	"	single- phase	Temp. I/O
38-00432	PQC 0614801-20	6 (440 V AC, 3 A, cos φ=1)	"	single- phase	Modbus RTU
38-00433	PQC 0614801-21	6 (440 V AC, 3 A, cos φ=1)	""	single- phase	Modbus RTU, Temp. I/O

<sup>4</sup> 85 V AC - 530 V AC (absolute limits, networks 100 V AC - 480 V AC), frequency 45 - 65 Hz or 100 V DC - 750 V DC (absolute limits)

## 10 Maintenance

The PQC needs no maintenance.

72



### **DANGER!**

The following instructions must be observed to avoid danger to life and limb:

- The instrument casing must not be opened.

The voltages inside the casing may present a hazard to health or may even be life-threatening if live components are inadvertently touched.

### 10.1 CLEANING



### **DANGER!**

The following instructions must be observed to avoid danger to life and limb:

- During cleaning, the instrument and the connecting cables must be isolated from the power supply.
- The isolated electrical system must be locked out to prevent its being inadvertently switched on again.
- The immediate vicinity must be covered.
- All connections must be checked to verify that they are no longer live!
- Power must not be switched on again to the installation until the cleaning work is completed.

When work is carried out in the vicinity of the instrument terminals and connecting cables, there is a risk of live components being touched inadvertently. A moist cleaning cloth, which conducts electricity, must never be used. The working voltage may present a hazard to health or may even be life-threatening.

If the above instructions are followed, the risk of endangering life and limb can be significantly reduced.

The instrument may only be cleaned with a dry cloth. When this is done, the above safety instructions must be followed. All power to the instrument must be switched off before cleaning is begun. Power must not be switched on to the instrument again until the cleaning procedure is completed.

If the cleaning is restricted only to the front of the closed control cabinet, it is not necessary to isolate the PQC from the power supply, but in this case also only a dry cleaning cloth may be used.



# 11 Decommissioning and removal, storage and disposal

## 11.1 DECOMMISSIONING AND REMOVAL

When decommissioning and removal work is carried out, please note the following:



### DANGER!

The following instructions must be observed to prevent danger to life and limb or damage to equipment and other assets:

- When the instrument is removed, it is essential to switch off the power to the instrument and the installation beforehand.
- The isolated electrical system must be locked out to prevent its being inadvertently switched on again.
- All connections must be checked to verify that they are no longer live!
- All live components in the immediate vicinity must be covered to prevent inadvertent contact.

When work is carried out on the instrument terminals and connecting cables, there is a risk of live components being touched inadvertently. The working voltage may present a hazard to health or may even be life-threatening.

If the above instructions are followed, the risk of endangering life and limb or damaging equipment can be significantly reduced.



### DANGER!

The following instructions must be observed to prevent danger to life and limb or damage to equipment and other assets:

- The current transformers must be short-circuited.
- All live cables must be disconnected from the instrument.
- All disconnected cables must be individually isolated and insulated, and measures must be taken to prevent their inadvertent contact with live components or electrically conducting parts.
- If it is intended that connecting cables that have been disconnected from the instrument are to become live again after the instrument has been removed, adequate measures must be taken to prevent their inadvertent contact with other live components or electrically conducting parts.

Exposed electrical conductors that can be touched are a hazard to life and limb. If they come into contact with other electrically conducting components, the latter can also become live. In addition, cables designated only for low voltages can carry life-threatening higher voltages if they come into contact with cables at the supply network voltage.

To prevent this danger to life and limb, the exposed ends of disconnected cables must be individually insulated in a workmanlike manner. The ends of these cables must not be joined to each other, and it must be ensured that cable ends cannot be touched, and that they do not touch each other or other components.

	<p><b>CAUTION!</b></p> <p>If the exposed ends of disconnected cables come into contact with each other, this can result in short-circuits and overloading of the installation conductors, resulting in damage to equipment and other assets.</p> <p>All disconnected cables must be individually isolated and insulated, and measures must be taken to prevent their inadvertent contact with live components or electrically conducting parts.</p>
---	---

#### Instrument removal:

	<p><b>DANGER!</b></p> <p>The following instructions must be observed to prevent danger to life and limb or damage to equipment and other assets:</p> <ul style="list-style-type: none"> <li>All power to the entire control cabinet must be switched off before the PQC is removed!</li> </ul> <p>If the above instructions are followed, and the precautions specified in Section 1.2, Safety instructions, are taken, the risk of damaging equipment and assets or endangering life and limb can be significantly reduced.</p>
---	--

- The PQC is held in place against the rear of the cabinet front wall by four retaining lugs in the corners of the instrument. These can be released by turning the retaining screws (accessible from the front) anticlockwise with a screwdriver. This slackens the four retaining lugs and swivels them to lie flat behind the PQC front panel, so that the instrument can then be withdrawn from the front of the cabinet.

## 11.2 STORAGE

- The PQC must be stored in a clean, dry and dust-free location.
- The storage temperature must be within the range -20 °C to +80 °C.

## 11.3 DISPOSAL

Any electronic instrument that is no longer required must be disposed of in an environmentally sound manner.

	<p><b>CAUTION!</b></p> <p>Incorrect disposal can cause environmental pollution.</p> <ul style="list-style-type: none"><li>• In the European Union, electrical scrap and electronic components are subject to the WEEE (Waste Electrical and Electronic Equipment) Directive. These components must not be disposed of as normal domestic or commercial waste.</li></ul> <p>If this is not complied with, there is a danger that environmental pollution may result and a violation of the Directive will have occurred.</p>
---	---

In other countries, the equivalent local regulations must be followed when electronic instruments are disposed of. They must be handed in at special recycling centres.

One way of ensuring environmentally sound disposal is to return the instruments to Schrack Technik or the company's local representatives. Alternatively, the instruments can be given to a firm specializing in the recycling of electronic equipment.



## 12 General operation

The following points must be observed when operating the instrument:

- The instrument must always be operated in a closed control cabinet as described in Section 4, Mounting the instrument.
- All voltages applied to the instrument must never exceed the limits specified in the technical data.
- The ambient temperatures must always be within the range specified in the technical data.

76

### 12.1 TROUBLESHOOTING

Faults during operation

If disruptions occur during operation of the PQC, the following table provides assistance in identifying and remedying the faults.

No.	Fault	Possible cause	Remedial action
1	PQC not working; no display at all on the screen	No power supply to the instrument, or the wrong voltage	Check whether the power supply at the correct voltage is reaching the PQC. Is the fuse in the power supply circuit in order?
2	The LCD backlighting comes on for a short time then goes off again, while the LCDs display nothing or only the starting logo—the instrument restarts repeatedly.	Supply voltage too low	Check whether the correct voltage is reaching the PQC. Is there is a high contact resistance in the power supply circuit?
3	Capacitor stage statuses display appears on screen but capacitor contactors are not activated.	Control circuit is not connected properly or there is no control voltage.	Check the control circuit against the connection diagram and check the fuses.
		No neutral conductor at the contactors.	
4	PQC cannot complete the automatic calibration procedure.	Heavy reactive power fluctuations	Wait for power supply to stabilize; set c/k factor and connection type manually.
5	During automatic calibration this message appears: <i>Alarm detected</i> <i>No cap. stage</i>	Fault in control circuit (contactors not switching)	Check the control circuit against the connection diagram and check the fuses.
		Capacitor stage discharge resistors are missing or defective	Check whether capacitors are energized after switching.
		Current transformer installed at the wrong location	Check whether the current transformer has been installed as per the connection diagram.
6	No value for current shown in the display	Break or short-circuit in the current transformer cable	Use an ammeter to check current in current path ( $I_{\min} \geq 0.015 \text{ A}$ ). Danger: see Section 5.5.
		The current in the current path is too low.	( $I_{\min} \geq 0.015 \text{ A}$ ) Install a smaller current transformer.
		Defective current transformer	Check the current transformer.

7	Despite inductive load, no stages are switched on when PQC is in automatic mode.	When the PQC was programmed, c/k, switching time delay, or discharge time have been set too high.	Check the PQC programming and change if necessary.
		In automatic operation, the response current c/k was not correctly identified.	Check the control circuit against the connection diagram and repeat the calibration procedure.
		Another current measuring instrument (e.g. an ammeter) has been connected in parallel with the current path.	All measuring instruments in the current path must be connected in series.
8	In automatic mode, one stage is continually being switched in and out (hunting).	The value of c/k was set too low when the PQC was programmed.	Set c/k value correctly according to the table.
		Severe load fluctuations; the delay time was set too low.	Set higher delay time.
9	The displayed power factor ( $\cos \varphi$ ) is less than the target power factor although the PQC has switched in all stages.	Type of connection incorrectly set.	Reset type of connection.
		Fault in control circuit	Check whether the capacitor contactors have been activated.
		Fault in capacitor circuit	Check the fuses and contacts of the capacitor contactors and possibly also measure the currents of each capacitor stage with a tong tester.
		System underdimensioned	Read off the corrective power still lacking from the menus.
10	PQC does not switch out all stages under low load conditions or during plant shutdown.	Faulty calibration	Repeat the calibration procedure.
		c/k set too high	Set c/k according to table.
		PQC is in manual mode.	Deactivate manual control.
		Wrong control profile selected	Adjust control profile to suit requirements.

## 13 Scope of supply

- 1 PQC instrument
- 4 different male connectors, supplied loose
- 1 operating manual



# THE COMPANY

## HEADQUARTERS

---

SCHRACK TECHNIK GMBH  
Seybelgasse 13, A-1230 Vienna  
PHONE +43(0)1/866 85-5900  
FAX +43(0)1/866 85-98800  
E-MAIL [export@schrack.com](mailto:export@schrack.com)

## SCHRACK COMPANIES

---

### BELGIUM

SCHRACK TECHNIK B.V.B.A  
Twaalfpostelenstraat 14  
BE-9051 St-Denijs-Westrem  
PHONE +32 9/384 79 92  
FAX +32 9/384 87 69  
E-MAIL [info@schrack.be](mailto:info@schrack.be)

### BOSNIEN-HERZEGOWINA

SCHRACK TECHNIK BH D.O.O.  
Put za aluminijski kombinat bb  
BH-88000 Mostar  
PHONE +387/36 333 666  
FAX +387/36 333 667  
E-MAIL [schrack@schrack.ba](mailto:schrack@schrack.ba)

### BULGARIA

SCHRACK TECHNIK EOOD  
Prof. Tsvetan Lazarov 162  
Druzha - 2  
BG-1000 Sofia  
PHONE +359/(2) 890 79 13  
FAX +359/(2) 890 79 30  
E-MAIL [safia@schrack.bg](mailto:safia@schrack.bg)

### CROATIA

SCHRACK TECHNIK D.O.O.  
Zavrtnica 17  
HR-10000 Zagreb  
PHONE +385 1/605 55 00  
FAX +385 1/605 55 66  
E-MAIL [schrack@schrack.hr](mailto:schrack@schrack.hr)

### CZECH REPUBLIC

SCHRACK TECHNIK SPOL. SR.O.  
Dolnomecholupska 2  
CZ-10200 Praha 10 – Hostivar  
PHONE +42(0)2/810 08 264  
FAX +42(0)2/810 08 462  
E-MAIL [paha@schrack.cz](mailto:paha@schrack.cz)

### HUNGARY

SCHRACK TECHNIK KFT.  
Vidor u. 5  
H-1172 Budapest  
PHONE +36 1/253 14 01  
FAX +36 1/253 14 91  
E-MAIL [schrack@schrack.hu](mailto:schrack@schrack.hu)

### GERMANY

SCHRACK TECHNIK GMBH  
Thomas-Wimmer-Ring 17  
D-80539 München  
PHONE +49 89/999 533 900  
FAX +49 89/999 533 902  
E-MAIL [info@schrack-technik.de](mailto:info@schrack-technik.de)

### POLAND

SCHRACK TECHNIK POLSKA SP.ZO.O.  
ul. Staniewicka 5  
PL-03-310 Warszawa  
PHONE +48 22/205 31 00  
FAX +48 22/205 31 01  
E-MAIL [kontakt@schrack.pl](mailto:kontakt@schrack.pl)

### ROMANIA

SCHRACK TECHNIK SRL  
Str. Simion Barnutiu nr. 15  
RO-410204 Oradea  
PHONE +40 259/435 887  
FAX +40 259/412 892  
E-MAIL [schrack@schrack.ro](mailto:schrack@schrack.ro)

### SERBIA

SCHRACK TECHNIK D.O.O.  
Kumodraska 260  
RS-11000 Beograd  
PHONE +38 1/11 309 2600  
FAX +38 1/11 309 2620  
E-MAIL [office@schrack.co.rs](mailto:office@schrack.co.rs)

### SLOVAKIA

SCHRACK TECHNIK S.R.O.  
Ivanská cesta 10/C  
SK-82104 Bratislava  
PHONE +42 (02)/491 081 01  
FAX +42 (02)/491 081 99  
E-MAIL [info@schrack.sk](mailto:info@schrack.sk)

### SLOVENIA

SCHRACK TECHNIK D.O.O.  
Pameče 175  
SLO-2380 Slovenj Gradec  
PHONE +38 6/2 883 92 00  
FAX +38 6/2 884 34 71  
E-MAIL [schrack.sg@schrack.si](mailto:schrack.sg@schrack.si)

[WWW.SCHRACK.COM](http://WWW.SCHRACK.COM)

MAN\_PQC\_EN\_2017\_06  
V6.0 2017\_06

