

INSTALLATION MANUAL

50160E

ecopanel



1300mA | 60W | IP20 | Aluminium

Driver must be ordered separately.
Optional suspension kit.
Order code 050017 (x2).

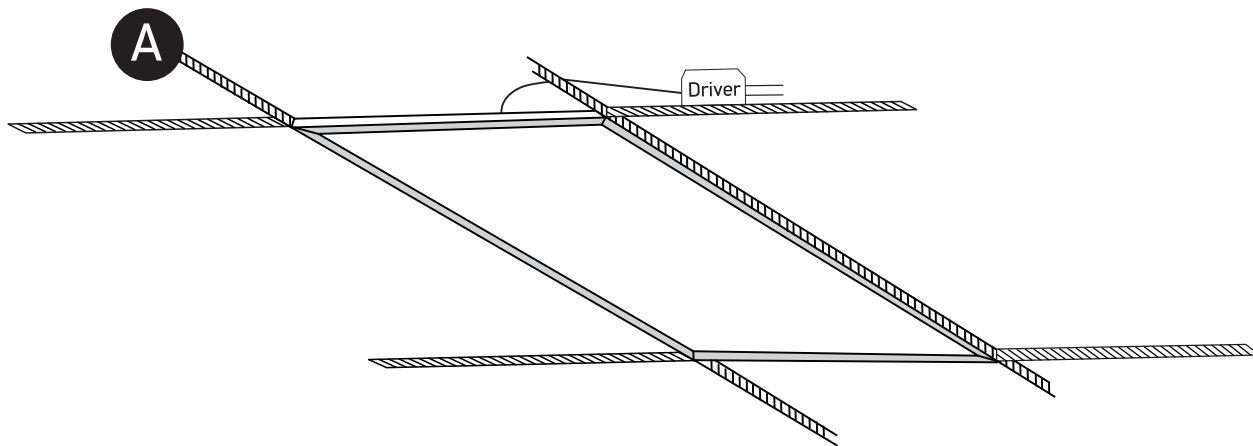
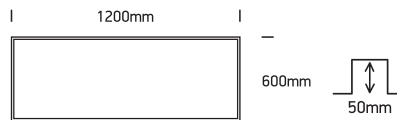

Recessed fitting for 1200x600mm T-rail false ceilings

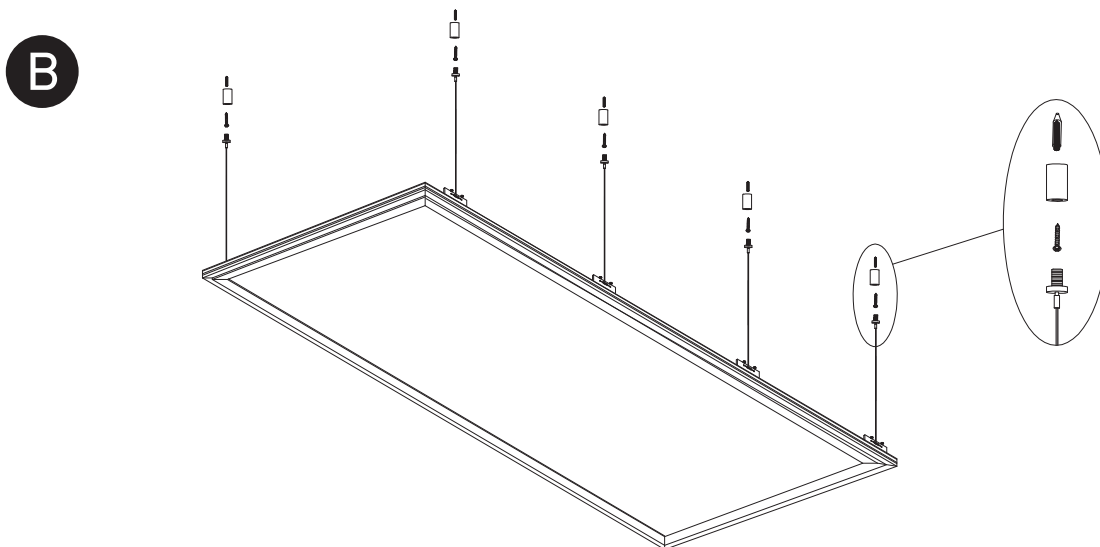

Ceiling mount suspended applications using optional kit 050017 (x2).

Warnings:

1. Make sure that the product is installed properly before connecting to electricity.
2. Do not cover the fitting.
3. Maintenance and installation should only be carried out by a professional electrician.