

QUADRON®185Power Größe 1-2-3

NH-Sicherungs-Lasttrennleiste
NH in-line fuse switch-disconnector
Seccionadores verticales para fusibles NH
réglette interrupteur-sectionneur-fusibles DIN
base sezion. verticale per fusibili NH
NH-条形熔断器式负荷隔离开关

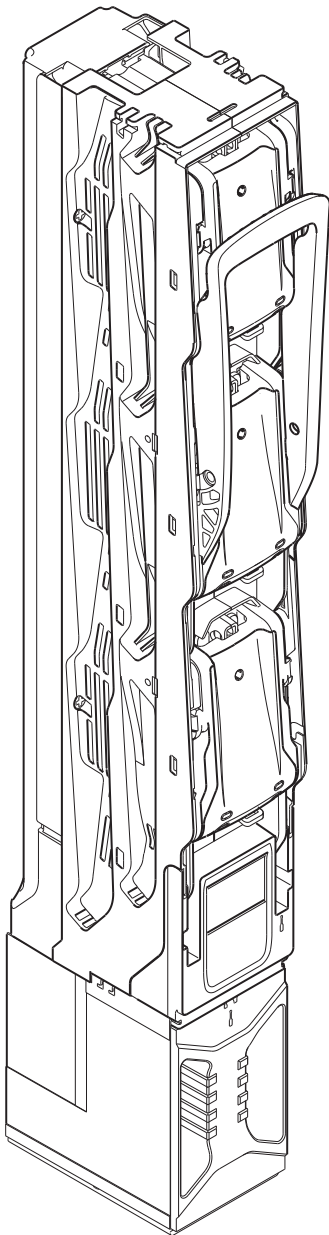

Achtung: Vor Installations- oder Servicearbeiten Stromversorgung unterbrechen, um Unfälle zu vermeiden. Die Geräte müssen in einem passenden Gehäuse eingebaut und gegen Verschmutzung geschützt werden. Inbetriebsetzung und Wartung nur durch Fachpersonal!

Attention: To prevent electrical shock, disconnect from power source before installing or servicing. Install in suitable enclosure. Keep free from contaminants. To be commissioned and maintained only by qualified personnel!

Atención: Con el objeto de evitar accidentes, hay que desconectar la alimentación eléctrica antes de realizar el montaje y la puesta en marcha. Debe instalarse en una caja o armario apropiado. Debe protegerse el producto de los ambientes agresivos. La puesta en marcha y el mantenimiento ha de hacerlo exclusivamente por personal especializado!

Attention: Avant le montage et la mise en service, couper l'alimentation secteur afin d'éviter tout accident. Prévoir une mise en coffret ou armoire appropriée, protéger le produit contre les environnements agressifs. Mise en service en entretien: seulement par du personnel spécialisé!

Attenzione: Per prevenire infortuni, togliere tensione prima dell'installazione o manutenzione. Installare in custodia idonea. Tenere lontano da contaminanti. Messa in servizio e manutenzione solo da personale specializzato!

注意: 安装前或检修前应切断电源, 以防事故。开关应安装在适合的箱体, 同时应做好防污染保护。只有专业人员才能做运行、维护、保养的工作。

1. Schienensystem

Busbar system

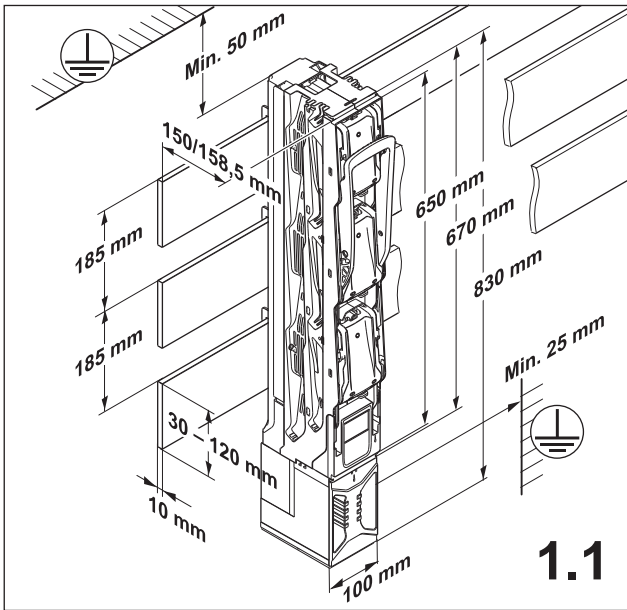

1.1

2. Montage QUADRON®185Power

Assembly

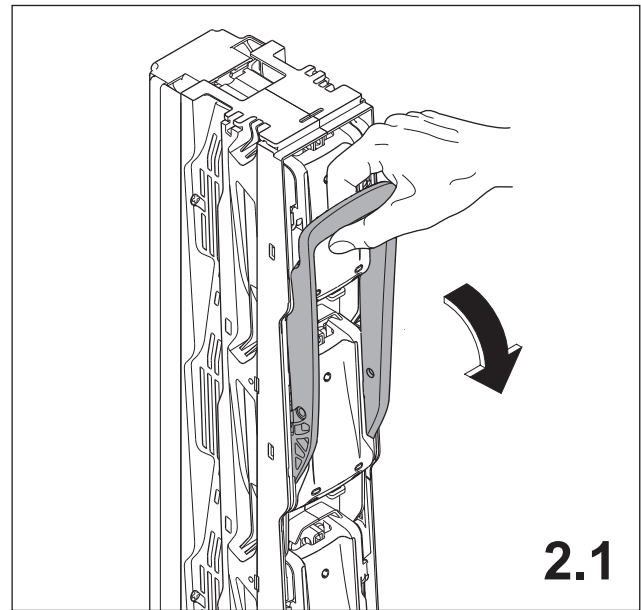

2.1

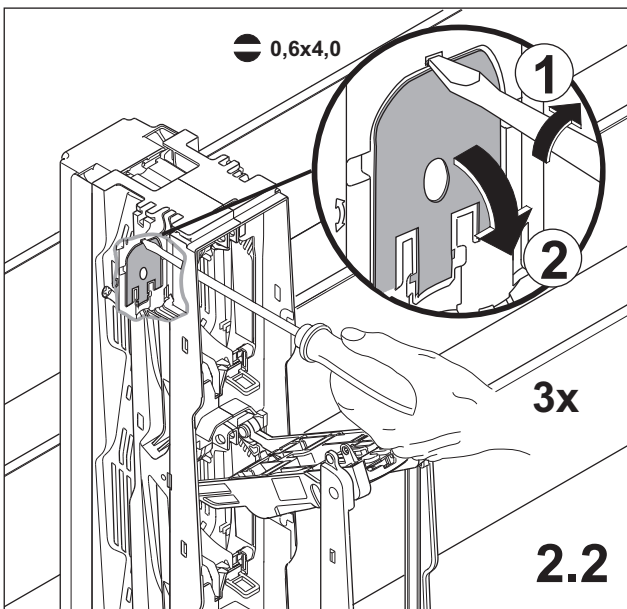

2.2

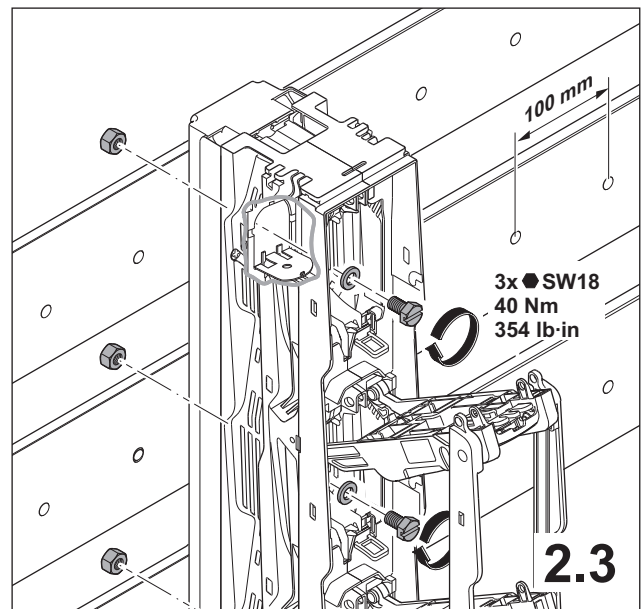

2.3

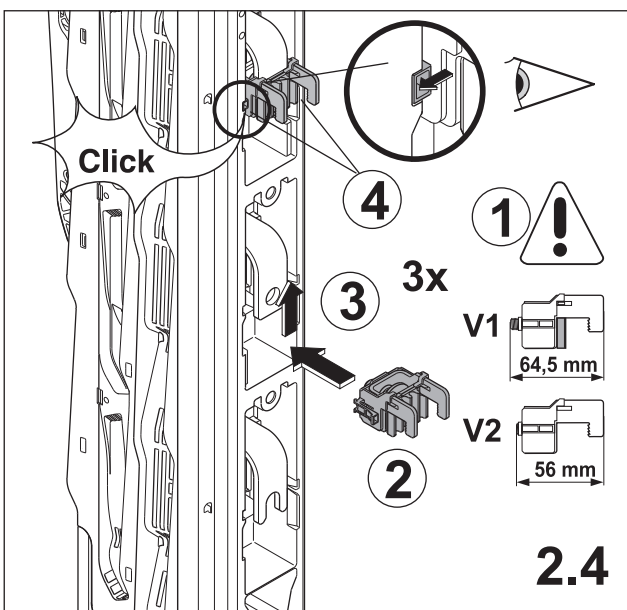

2.4

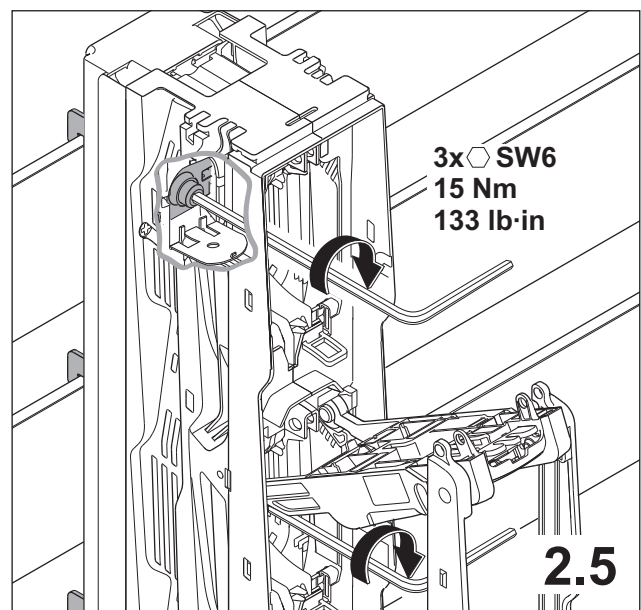

2.5

3. Anschlüsse

Connections

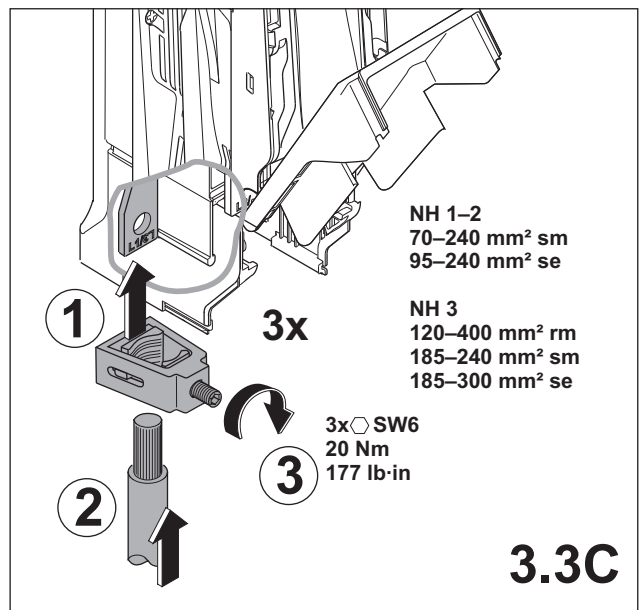
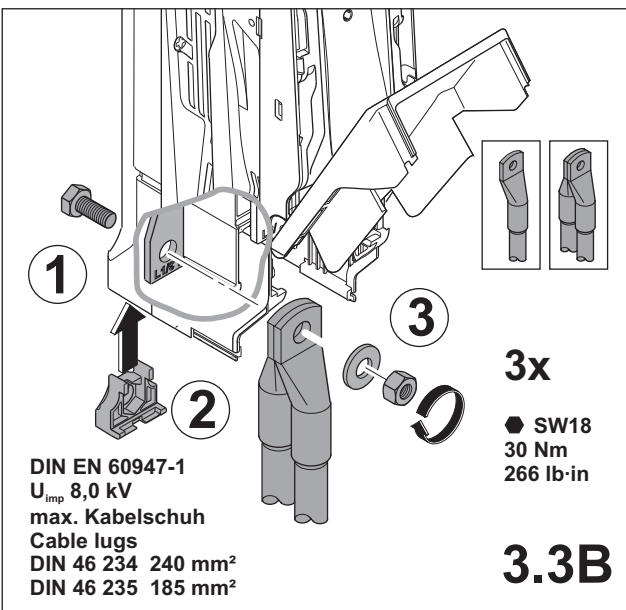
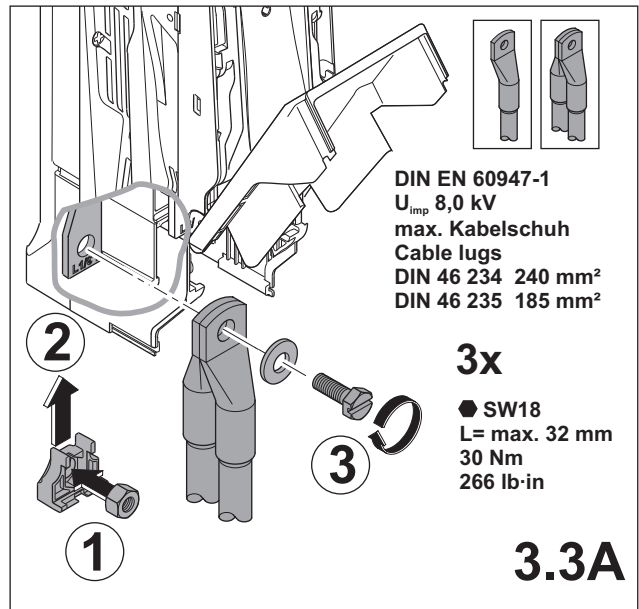
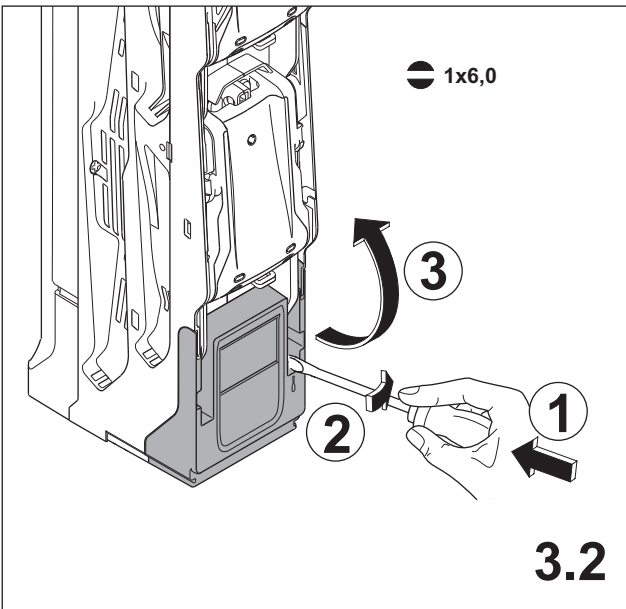
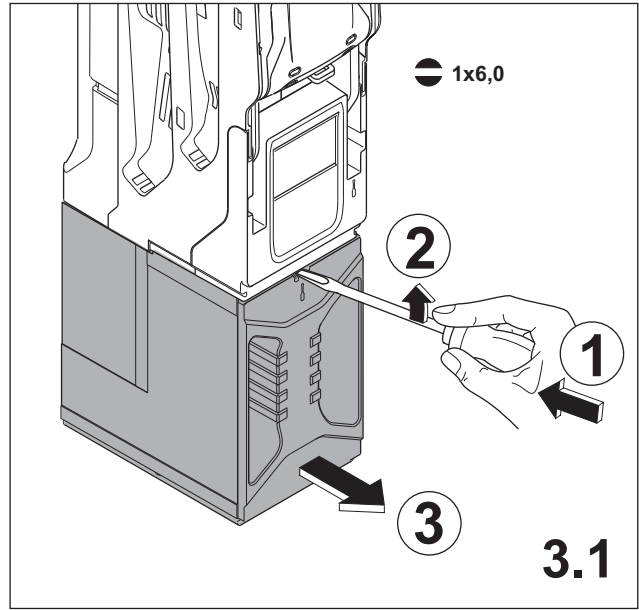
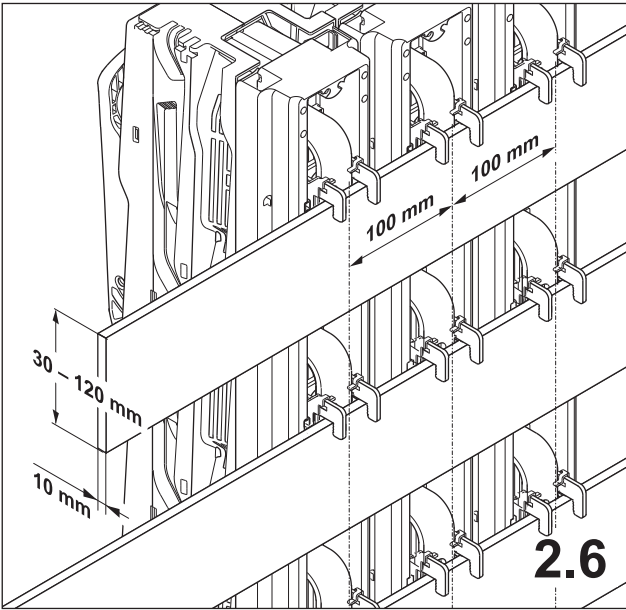

4. Anschlüsse oben

Connection up

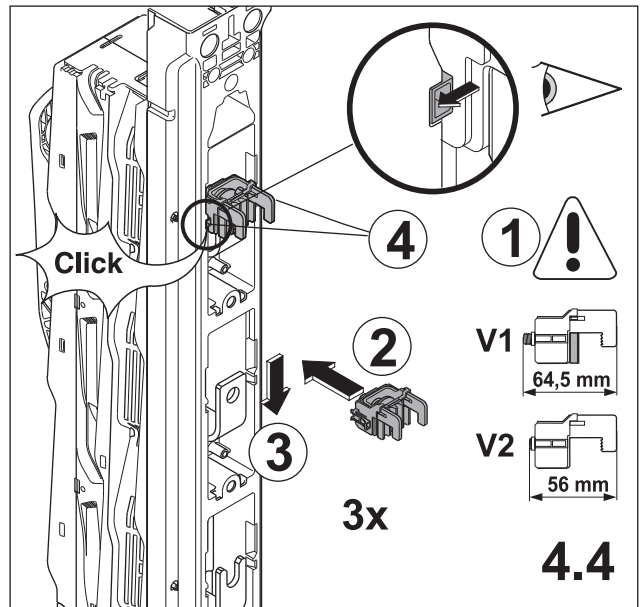
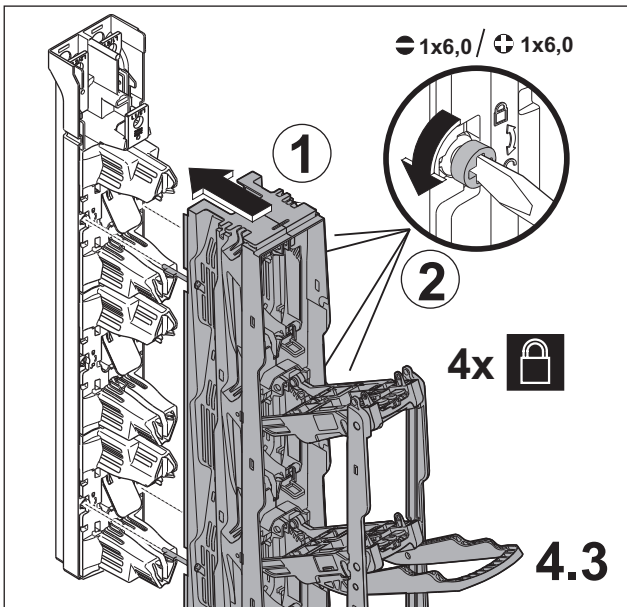
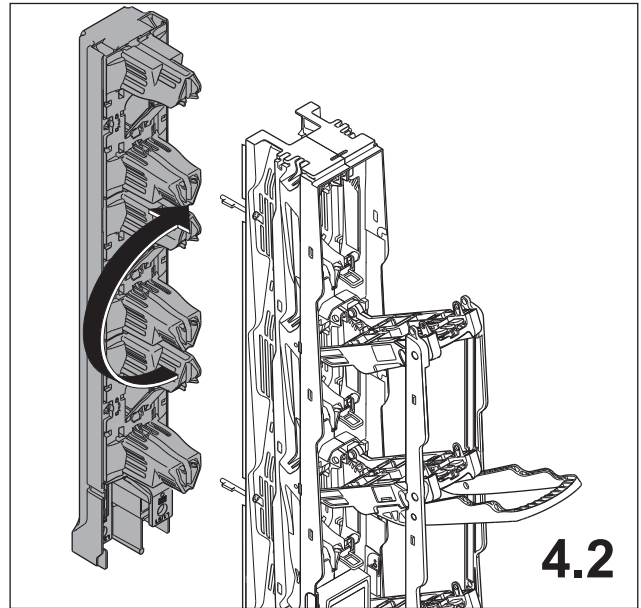
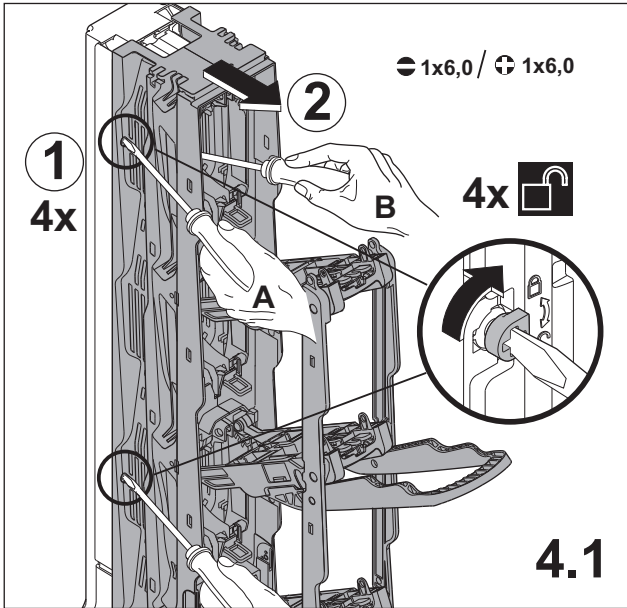

5. Abdeckung immer verwenden

Always use the cover

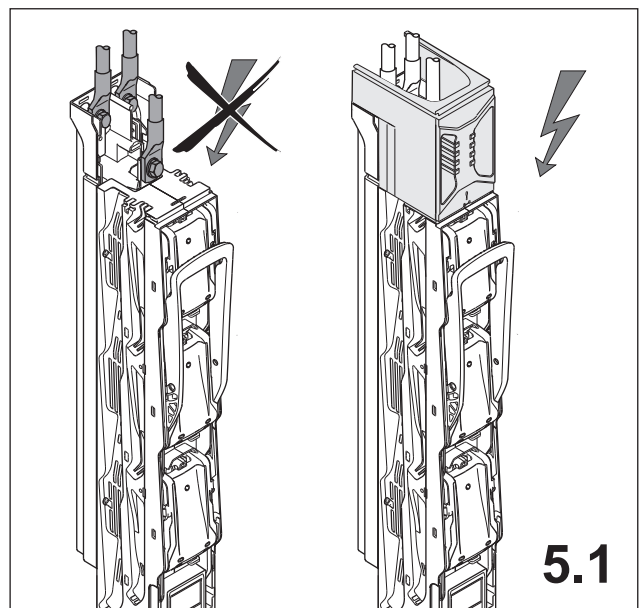
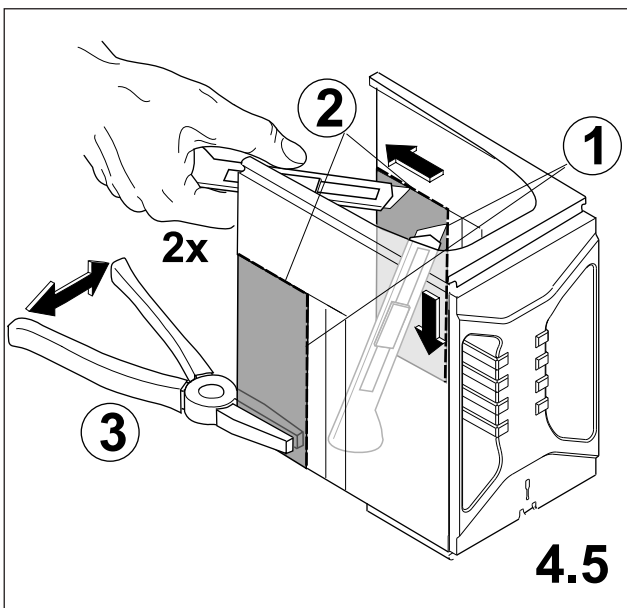

6. Sicherungen auswechseln Change the fuses

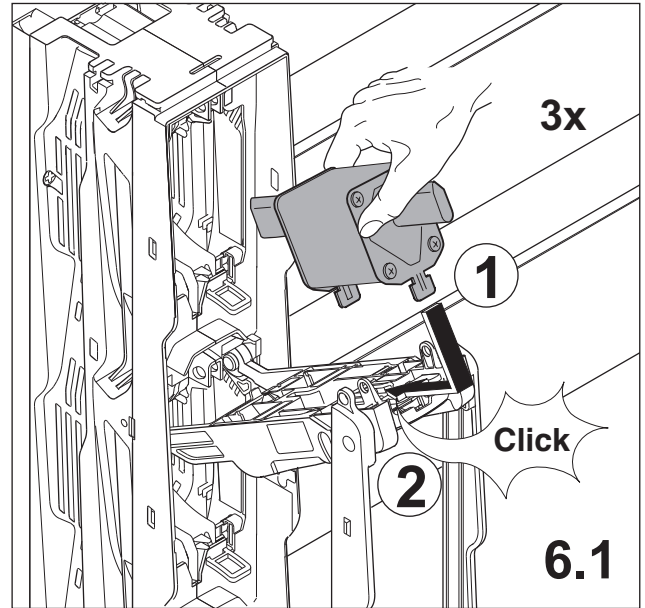
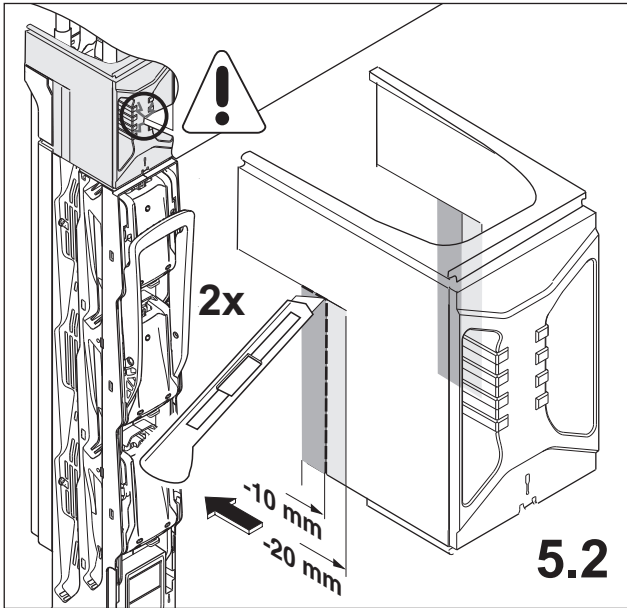

7. Abschließbarkeit 3-polig Locking the fuse holder three-pole

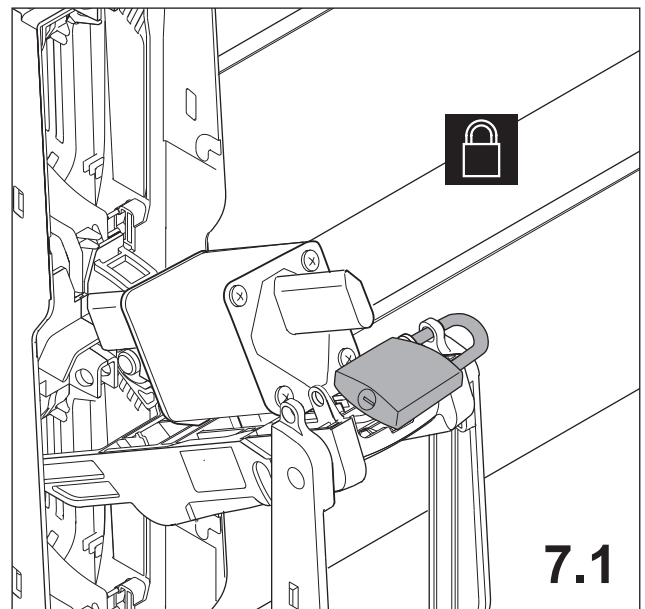
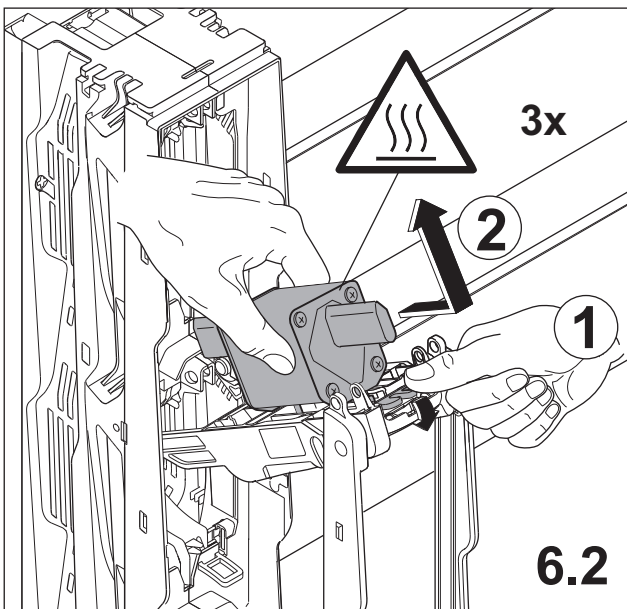

8. Abschließbarkeit 1-polig Locking the fuse holder single-pole

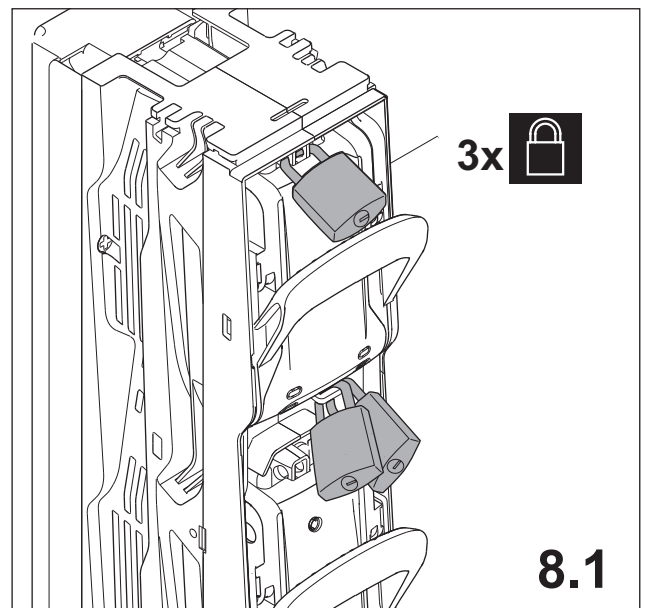
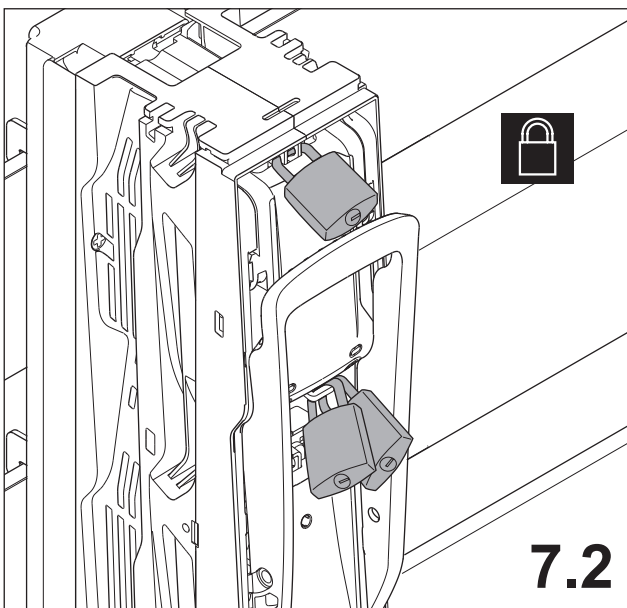

9. Plombieren der NH-Leiste

Sealing of fuse holder

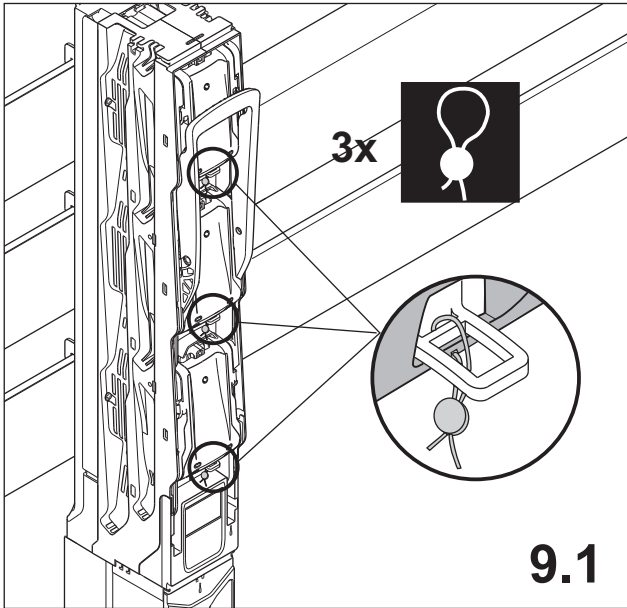

10. Parkposition 1-polige NH-Leiste Parking position single-pole

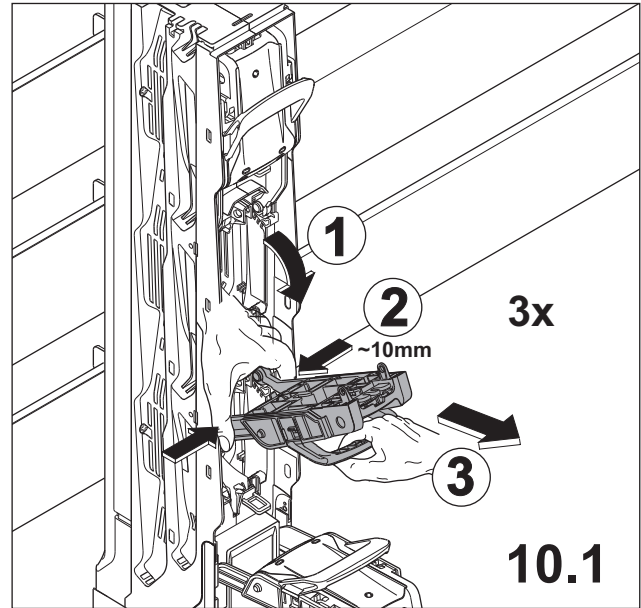

11. Spannungsprüfung

Voltage test

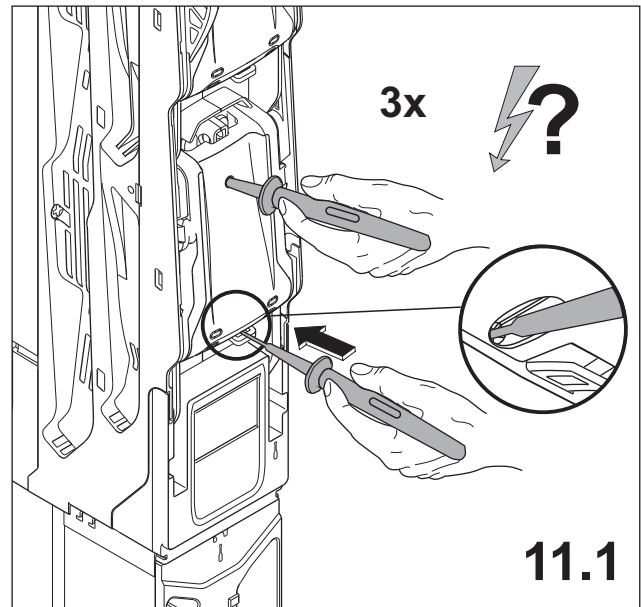
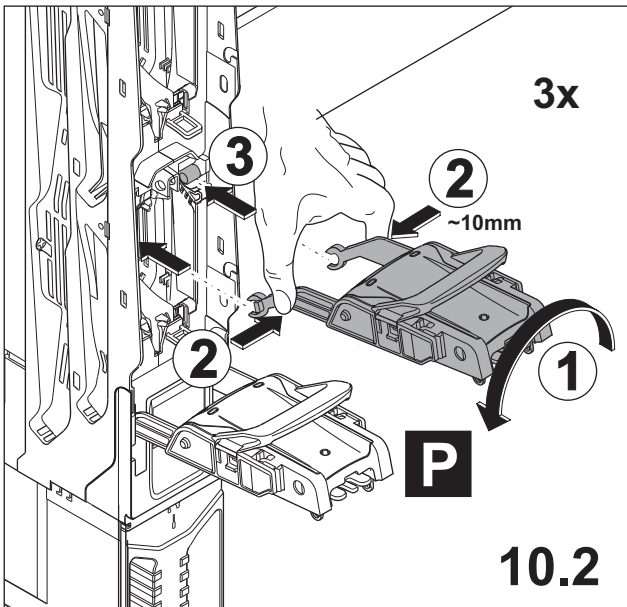

12. Zubehör - Stromwandler - Einbau und Kabelverlegung

Accessories - Current transformer - assembly and cable routing

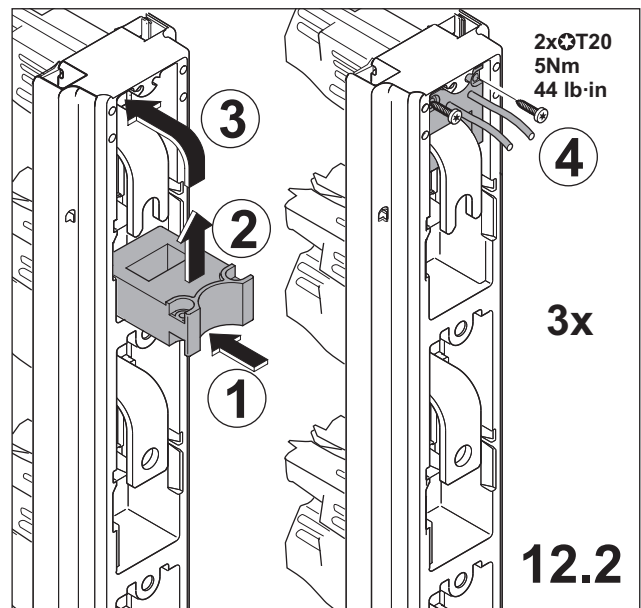
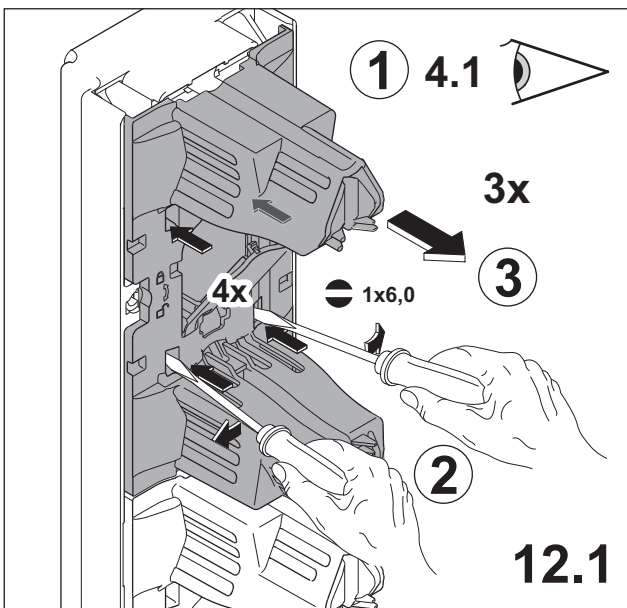

12.4 A Kabelverlegung nach unten Cable routing bottom side

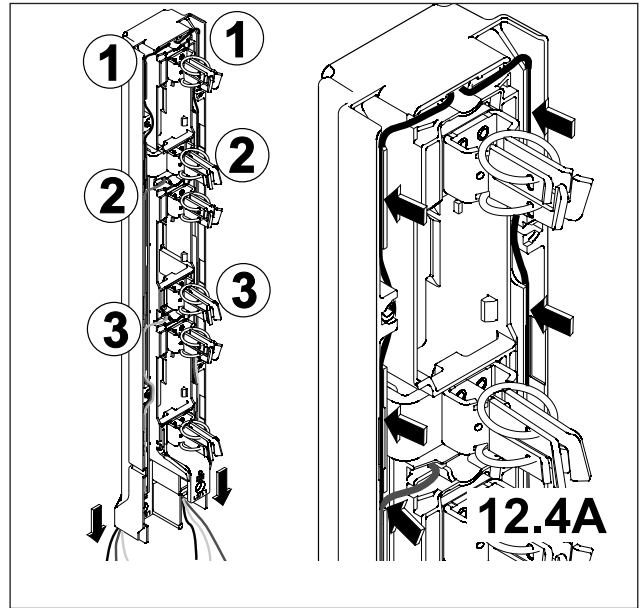
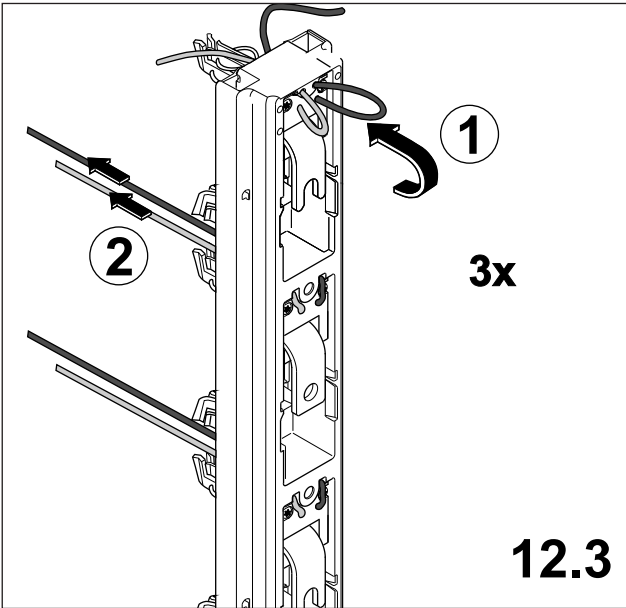

12.4 B Kabelverlegung nach oben Cable routing top side

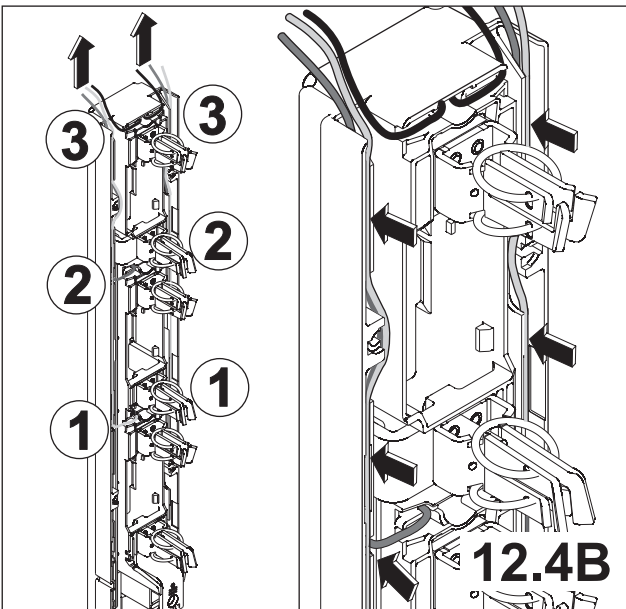

13. A Meldeschalter - Einbau und Kabelverlegung innen Pilot switch - assembly and cable routing inside

