

EL[®]MARK

The Brand of Electricity

ASTRA LED CEILING LAMP



GENERAL INFORMATION »

- ∴ Power: 18W
- ∴ Rated voltage: 230V; 50-60Hz
- ∴ Colour temp.: 4000K
- ∴ Power Supply: control gear, DC device-driver
- ∴ LED type: SMD
- ∴ Colour rendering index: Ra≥80
- ∴ Average Lifetime: 30 000h
- ∴ Body: Metal
- ∴ Colour of the body: Chrome
- ∴ Installation: Surface mounted luminaire
- ∴ Protection against dust and moisture: IP40

FEATURES »

- ∴ Stylish and modern
- ∴ Pleasant and uniform light distribution
- ∴ Low power consumption
- ∴ Repeated switch on/off does not affect the lifespan
- ∴ Safety, low voltage operation
- ∴ Instant light with maximum luminous flux
- ∴ Environmentally friendly - no mercury and lead
- ∴ No ultraviolet and infrared rays

AREAS OF APPLICATION »

- ∴ Residential and Commercial buildings
- ∴ Home interior
- ∴ Hotels and Restaurants

TECHNICAL SPECIFICATION SHEET

PRODUCT DETAILS »

Catalogue number	Watt (W)	Whole fixture lumens (lm)	Colour temp. (K)	Colour body
95ASTRA24LED	24	1440	4000	Chrome

DIMENSIONS »

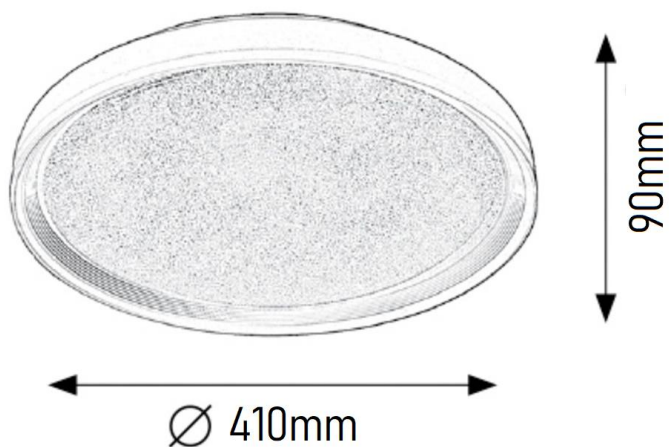

CONNECTIONS »

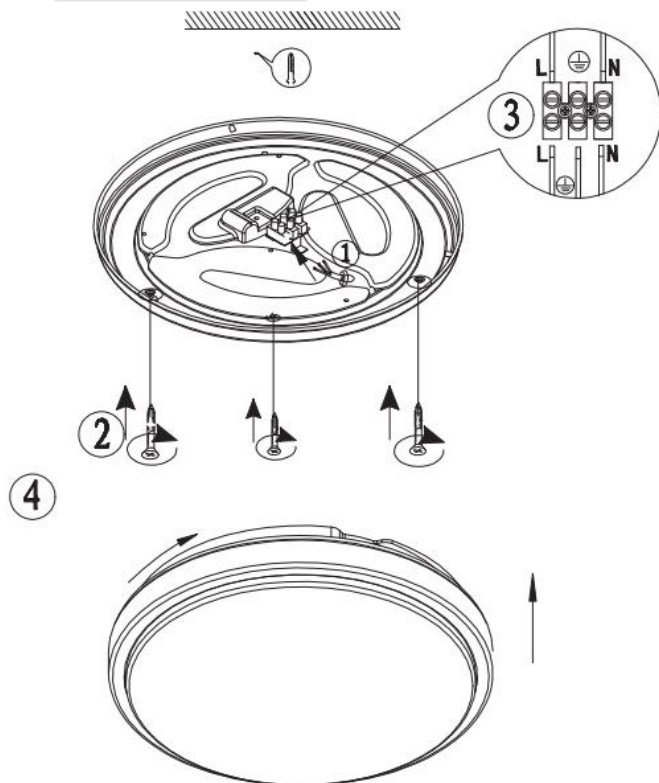

ADDITIONAL INFORMATION »

ELMARK lighting **ASTRA**

 This luminaire contains built-in LED lamps.

A++ } **L**
A+ } **E**
A } **D**
~~**B**~~
~~**C**~~
~~**D**~~
~~**E**~~

The lamps cannot be changed in the luminaire.

874/2012 

Catalogue number	Barcode	Packing/Box (pcs)
95ASTRA24LED	3800131228697	1/1