

TECHNICAL SPECIFICATION

ONE CHANEL RECHARGEABLE LED PANEL REMOTE



- Removable and stick anywhere easily.
- Built-in rechargeable Li-Battery.
- DIM remoter are available.
- With on/off state and touch operation indication.
- Adopt 2.4GHz wireless technology, wireless 30m control.
- Can remote control multiple controllers or lamps.
- High precision touch chip with high sensitive & high stability touch control.

Technical data:

Output signal:	RF (2.4G)
Remote distance:	30m
Li-battery capacity:	200mAh
Working current:	< 20mA
Standby current:	< 30μA
Standby time:	6 months
Working temperature:	-30°C~55°C
Product size:	L86×W86×H13.5mm
Net weight:	90g
Catalogue number:	99TOUCHUSB1

Dimensions:

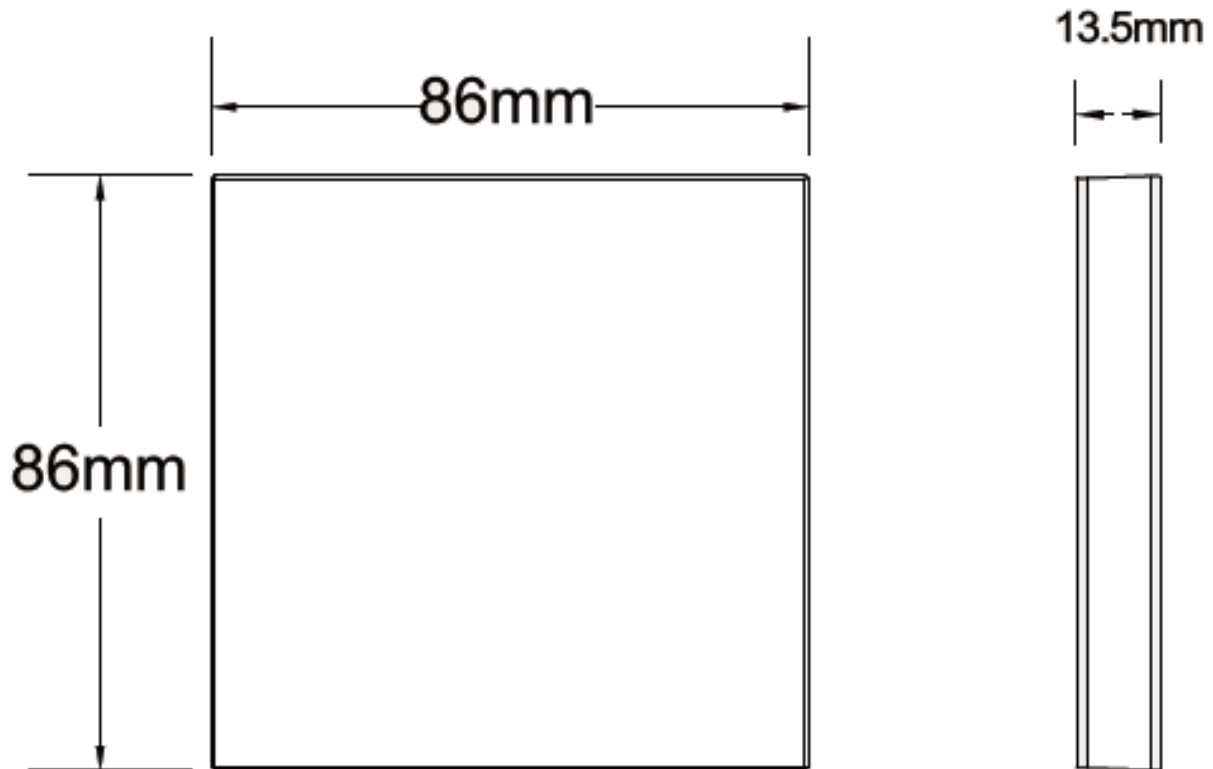

Match method:

- **For controller with match key**
 - **Match:** Short press match key, within 5s, press any key of the remoter.
 - **Delete:** Long press match key for 5s, delete all matched remote.

- **For smart lamp or controller without match key**
 - **Match:** Switch off the power, then switch on power again, short press on/off key 3 times on the remoter quickly within 5s after power on, the link is done once the light blinks 3 times.
 - **Delete:** Switch off the power, then switch on power again, short press on/off key 5 times on the remoter quickly within 5s after power on, the unlink is done once the light blinks 5 times.

Key functions:

To extend battery life, no touch operation after a few seconds, the panel will enter sleep state. You may need touch more than 1 second to quit sleep state. When touch is valid, the upper blue light is on, otherwise you need plug in USB cable to charge the panel, when charge complete, the bottom-right red light is off

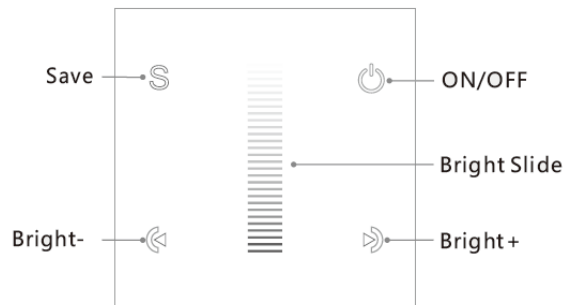

Apply to single color LED lamp.

ON/OFF: Turn on/off light.

Bright Slide: Touch to change brightness.

Save: Short press get the saved brightness, long press 2s save.

Bright+/-: Adjust brightness, short press 10 levels, long press 1-5s continuous 256 levels adjustment.

Installation diagram:

1. Use screw

- Flip panel, inserted into the card edge aperture with a small screwdriver, gently pry and open the panel.
- Put in the screw to bottom case and tighten, moderately cover upper case.

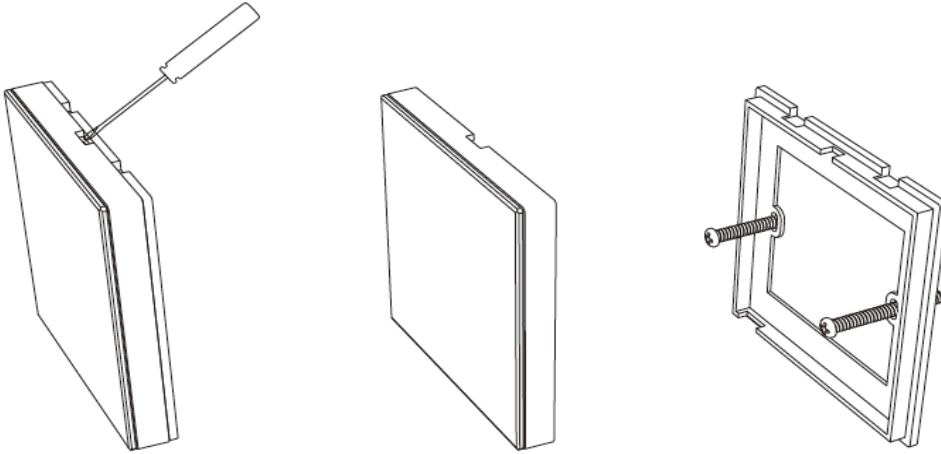

2. Use 3M tape paste

- Flip panel, tear apart 3M tape, paste on the top and bottom of the back of the panel.
- Paste panel on the wall or anywhere.

