

Scan me!

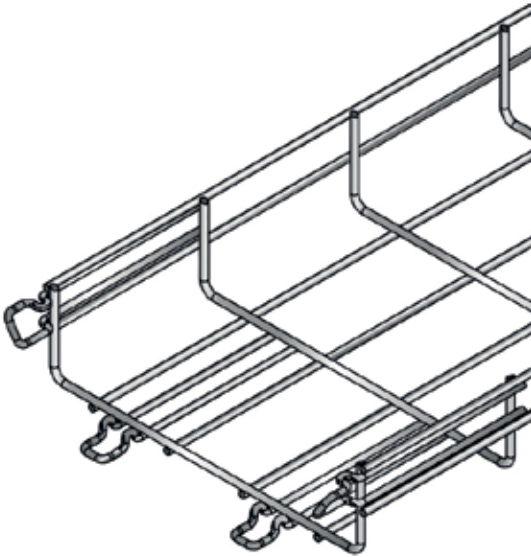

Or download our  
documentation on  
[www.nxf-pdf.fr/en](http://www.nxf-pdf.fr/en)

# MESH TRAY



<b>Automatic</b> 	p. 102
<b>Standard UF</b>	p. 106
<b>Specific installations</b>	p. 109
<b>Accessories</b>	p. 111

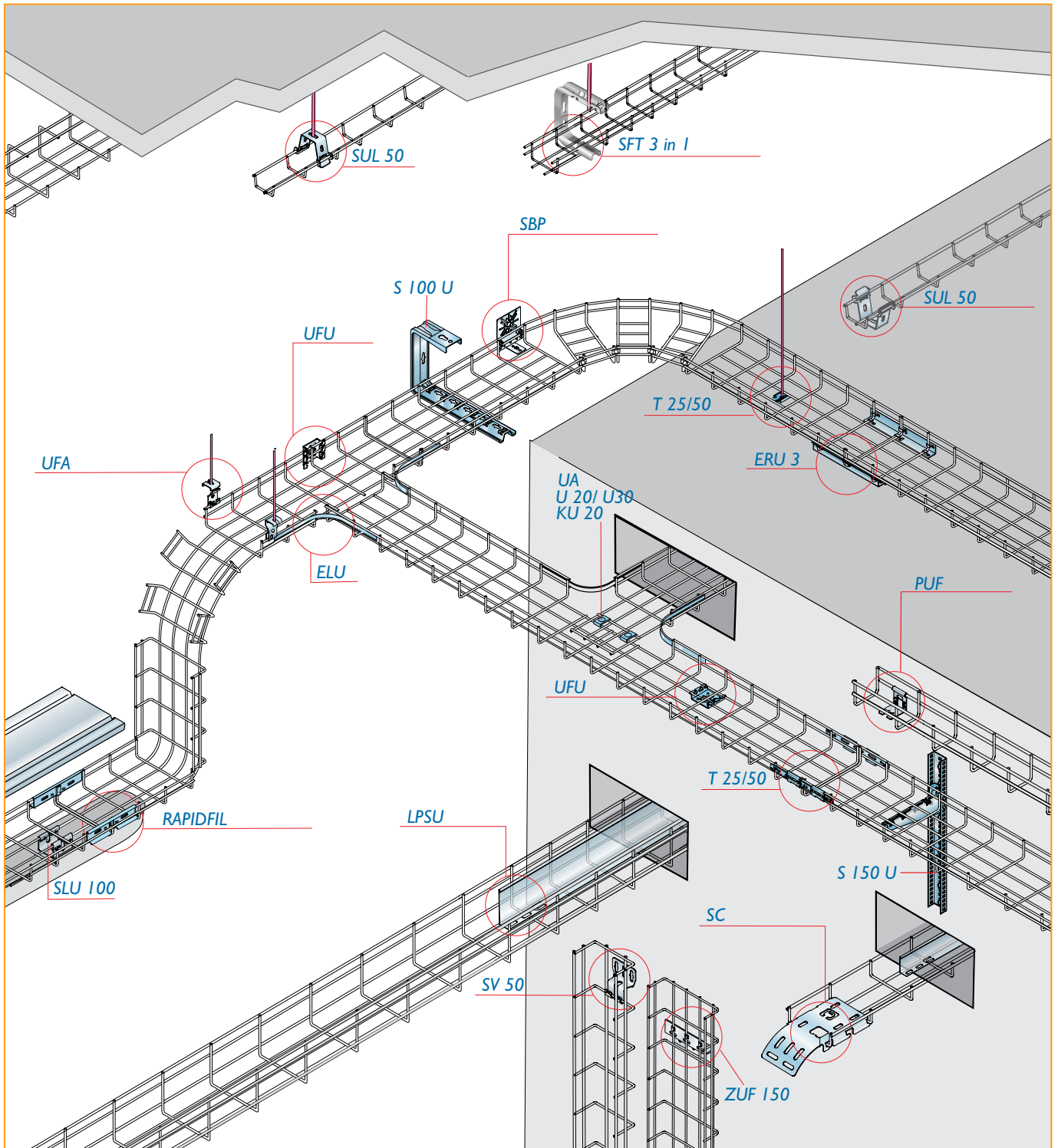

MTC & UNIFIL MESH TRAY

**APPLICATIONS:**

Any commercial or industrial installation requiring easy identification and ventilation of cables.

**BENEFITS:**

- Simple design and quick installation
- Electrical continuity in compliance with IEC 61537 international standard
- Natural identification and ventilation of cables
- Safety for cables and contractors (easy / light handling)
- Aesthetic for used in any location
- Hygienic as no dust or bacterium accumulation
- Adjustable for easy retrofitting
- Recyclable as contains no chromium
- Comprehensive range of ancillary items suitable for any installation configuration
- Large range of heights (30 to 100 mm) and widths (50 to 600 mm)
- Direct ceiling - or wall - mounted G-shaped range.

**SPECIFICATIONS:**

NIEDAX France mesh tray range UNIFIL (UF) with safety flange and adapted wire diameter optimising loading capacity in accordance with IEC 61537 international standard. This specification is a format for engineering specification.

*This format is to be used as a guide.*

*Some conditions of the intended application, however, may require modifications.*

MTC / UF	Maximum capacity (kg/ml) for a density of					
	Power cables 0,25 kg/cm <sup>2</sup> /ml			Communication cables 0,15 kg/cm <sup>2</sup> /ml		
	Width (mm)	Height (mm)			Height (mm)	
	30	54	105	30	54	105
50	3,8	6,8		2,3	4,1	
100	7,5	13,5	25,0	4,5	8,1	15,0
150	11,3	20,3	37,5	6,8	12,2	22,5
200	15,0	27,0	50,0	9,0	16,2	30,0
300	22,5	40,5	75,0	13,5	24,3	45,0
400		54,0	10,0		32,4	60,0
500		67,5	125,0		40,5	75,0
600		80,4	150,0		48,0	90,0

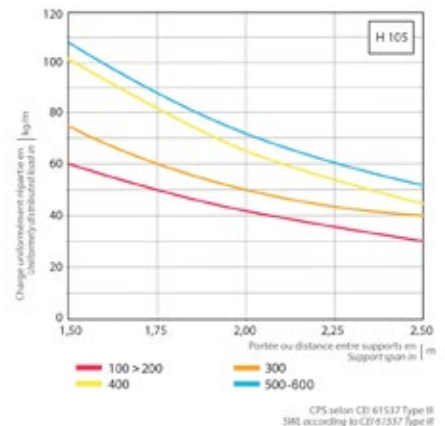
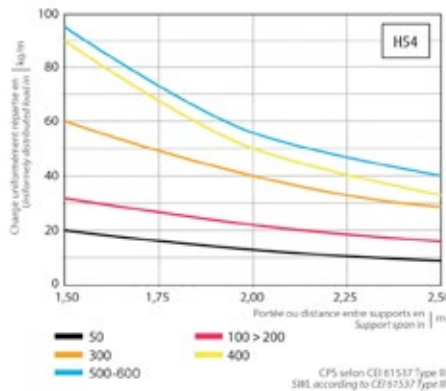
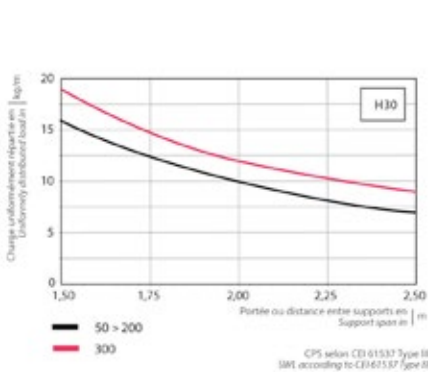

MESH TRAY CITO (MTC)

Fully automatic Mesh Tray CITO (MTC) for easier and quicker installation!

- Ideal for narrow spaces. CITO suits all sorts of configurations, even the toughest ones.
- No coupling accessories required: CITO assembly is automatic just by clicking one tray into the other.
- Compatible with all our range of accessories.
- Equivalent resistance to our standard system with traditional coupling.

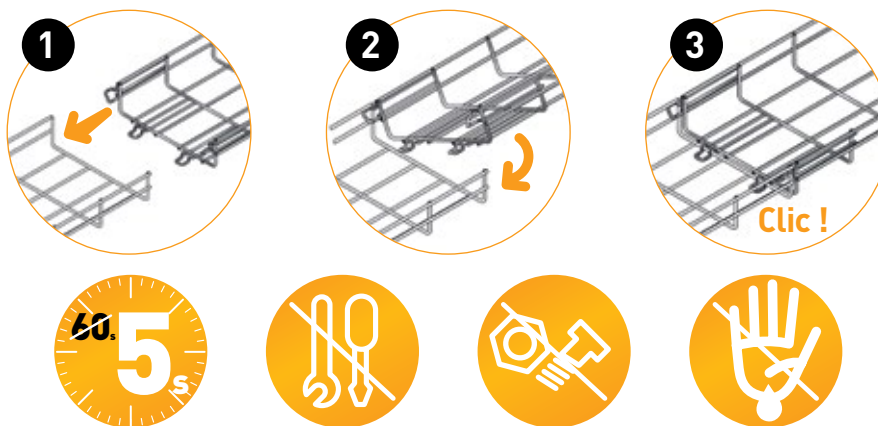
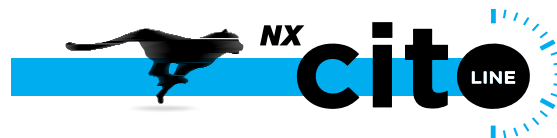

MTC H30

30 mm 50 ▶ 300 mm

M	Description	Code	Weight Kg/ml
EZ	3 MTC 30x50 EZ	711215	0.410
	3 MTC 30x100 EZ	711222	0.550
	3 MTC 30x150 EZ	711239	0.700
	3 MTC 30x200 EZ	711246	0.840
	3 MTC 30x300 EZ	711253	1.130
M	Description	Code	Weight Kg/ml
HDG	3 MTC 30x50 HDG	712014	0.450
	3 MTC 30x100 HDG	712021	0.610
	3 MTC 30x150 HDG	712038	0.770
	3 MTC 30x200 HDG	712045	0.930
	3 MTC 30x300 HDG	712052	1.240
M	Description	Code	Weight Kg/ml
SS304	3 MTC 30x50 SS304	713011	0.420
	3 MTC 30x100 SS304	713028	0.560
	3 MTC 30x150 SS304	713035	0.720
	3 MTC 30x200 SS304	713059	0.860
	3 MTC 30x300 SS304	713066	1.150
M	Description	Code	Weight Kg/ml
SS316	3 MTC 30x50 SS316	714018	0.420
	3 MTC 30x100 SS316	714025	0.560
	3 MTC 30x150 SS316	714032	0.720
	3 MTC 30x200 SS316	714049	0.860
	3 MTC 30x300 SS316	714056	1.150

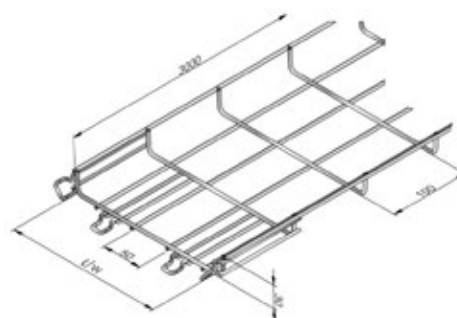

NEW !

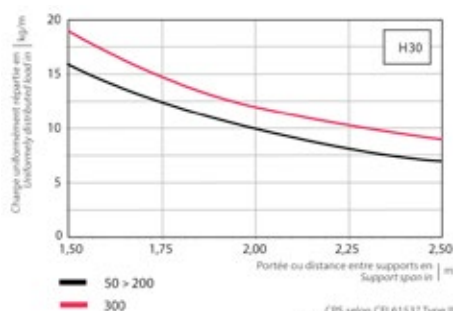
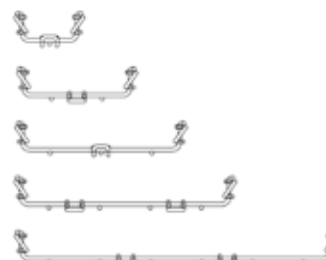
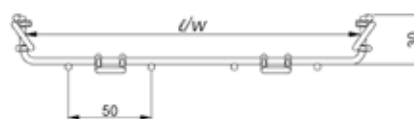

CPS selon CEI 61537 Type III  
SRII according to CEI 61537 Type III



MESH TRAY CITO (MTC)

MTC H54

54 mm 50 ▶ 600 mm

**NEW !**

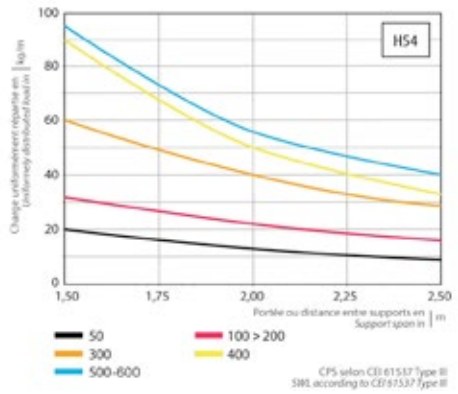
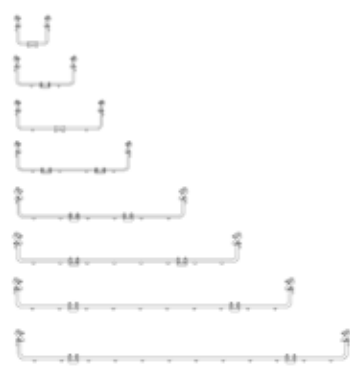
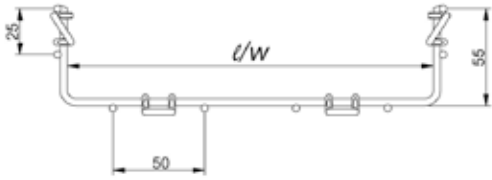
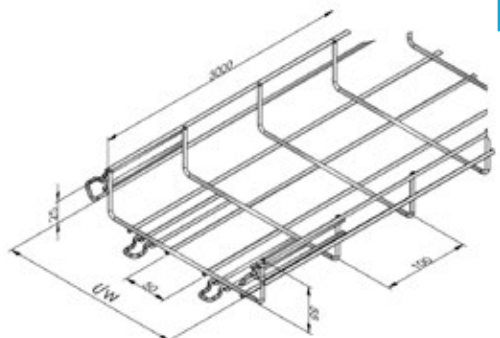

M	Description	Code	Weight Kg/ml
EZ	3 MTC 54x50 EZ	711260	0.650
	3 MTC 54x100 EZ	711277	0.790
	3 MTC 54x150 EZ	711284	0.940
	3 MTC 54x200 EZ	711291	1.080
	3 MTC 54x300 EZ	711314	2.100
	3 MTC 54x400 EZ	711321	2.870
	3 MTC 54x500 EZ	711338	3.370
	3 MTC 54x600 EZ	711345	3.880

M	Description	Code	Weight Kg/ml
HDG	3 MTC 54x50 HDG	712069	0.710
	3 MTC 54x100 HDG	712076	0.870
	3 MTC 54x150 HDG	712083	1.030
	3 MTC 54x200 HDG	712090	1.190
	3 MTC 54x300 HDG	712113	2.310
	3 MTC 54x400 HDG	712120	3.160
	3 MTC 54x500 HDG	712137	3.710
	3 MTC 54x600 HDG	712144	4.260

M	Description	Code	Weight Kg/ml
SS304	3 MTC 54x 50 SS304	713073	0.660
	3 MTC 54x100 SS304	713080	0.800
	3 MTC 54x150 SS304	713097	0.960
	3 MTC 54x200 SS304	713110	1.100
	3 MTC 54x300 SS304	713134	2.140
	3 MTC 54x400 SS304	713165	2.930
	3 MTC 54x500 SS304	713189	3.450
	3 MTC 54x600 SS304	713219	3.960

M	Description	Code	Weight Kg/ml
SS316	3 MTC 54x50 SS316	714063	0.660
	3 MTC 54x100 SS316	714070	0.800
	3 MTC 54x150 SS316	714087	0.960
	3 MTC 54x200 SS316	714094	1.100
	3 MTC 54x300 SS316	714117	2.140
	3 MTC 54x400 SS316	714124	2.930
	3 MTC 54x500 SS316	714131	3.450
	3 MTC 54x600 SS316	714148	3.960

MESH TRAY CITO (MTC)

MTC H105

54 mm 50 ▶ 600 mm

NEW!

M	Description	Code	Weight Kg/ml
EZ	3 MTC 105x100 EZ	711352	1.070
	3 MTC 105x150 EZ	711369	1.220
	3 MTC 105x200 EZ	711376	2.100
	3 MTC 105x300 EZ	711383	2.870
	3 MTC 105x400 EZ	711390	3.370
	3 MTC 105x500 EZ	711413	3.880
	3 MTC 105x600 EZ	711420	4.380

M	Description	Code	Weight Kg/ml
HDG	3 MTC 105x100 HDG	712151	1.180
	3 MTC 105x150 HDG	712168	1.340
	3 MTC 105x200 HDG	712175	2.310
	3 MTC 105x300 HDG	712182	3.160
	3 MTC 105x400 HDG	712199	3.710
	3 MTC 105x500 HDG	712212	4.260
	3 MTC 105x600 HDG	712229	4.820

M	Description	Code	Weight Kg/ml
SS304	3 MTC 105x100 SS304	713233	1.100
	3 MTC 105x150 SS304	713264	1.250
	3 MTC 105x200 SS304	713288	2.150
	3 MTC 105x300 SS304	713318	2.950
	3 MTC 105x400 SS304	713325	3.460
	3 MTC 105x500 SS304	713332	3.980
	3 MTC 105x600 SS304	713349	4.490

M	Description	Code	Weight Kg/ml
SS316	3 MTC 105x100 SS316	714155	1.100
	3 MTC 105x150 SS316	714162	1.250
	3 MTC 105x200 SS316	714179	2.150
	3 MTC 105x300 SS316	714186	2.950
	3 MTC 105x400 SS316	714193	3.460
	3 MTC 105x500 SS316	714216	3.980
	3 MTC 105x600 SS316	714223	4.490

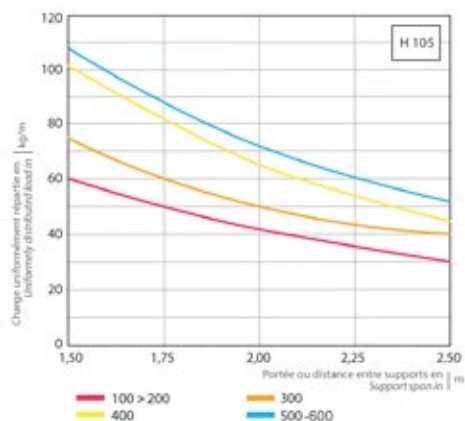
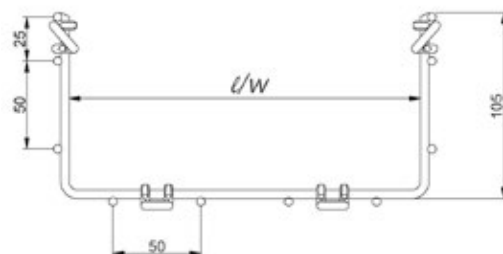
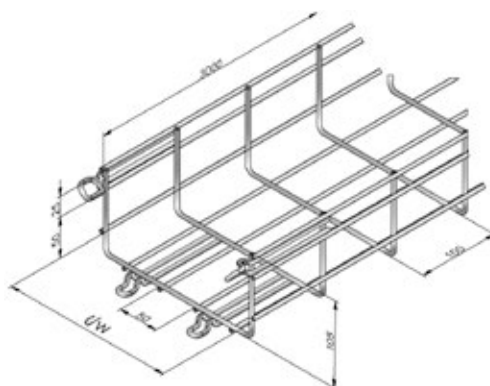

CPS selon CEI 61537 Type III  
SWL according to CEI 61537 Type III

CONNECTING UNITS

Adjustable bend delivered as a straight section :

- Easy to install: **no bolts, no tools**
- Bend manually to obtain horizontal or vertical bends with adjustable angle (0° to 90°)
- Other materials and finishes upon request

MTCE ADJUSTABLE BENDS

54 mm 100 300 mm

NEW !

P	Description	Code	Weight Kg/p
EZ	1 MTCE 54x100 EZ	711512	0.326
	1 MTCE 54x150 EZ	711536	0.390
	1 MTCE 54x200 EZ	711550	0.569
	1 MTCE 54x300 EZ	711574	1.109
P	Description	Code	Weight Kg/p
HDG	1 MTCE 54x100 HDG	712311	0.326
	1 MTCE 54x150 HDG	712335	0.390
	1 MTCE 54x200 HDG	712359	0.569
	1 MTCE 54x300 HDG	712373	1.109
P	Description	Code	Weight Kg/p
SS304	1 MTCE 54x100 SS304	713424	0.326
	1 MTCE 54x150 SS304	713431	0.390
	1 MTCE 54x200 SS304	713455	0.569
	1 MTCE 54x300 SS304	713462	1.109
P	Description	Code	Weight Kg/p
SS316	1 MTCE 54x100 SS316	714315	0.326
	1 MTCE 54x150 SS316	714322	0.390
	1 MTCE 54x200 SS316	714339	0.569
	1 MTCE 54x300 SS316	714346	1.109

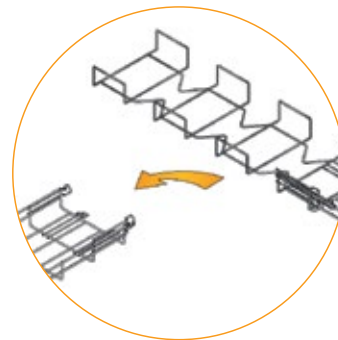
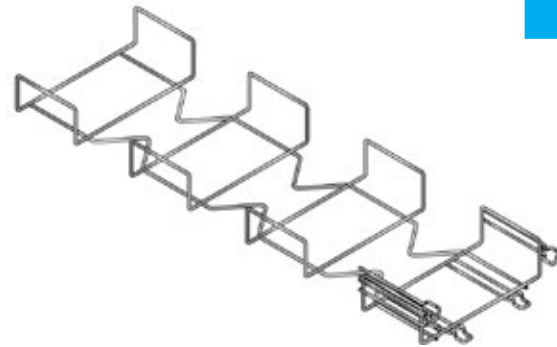

UNIFIL (UF)

Solutions for any building site configuration

- Simple
- Safe
- Quick

UF H30

30 mm 50 ▶ 300 mm

M	Description	Code	Weight Kg/ml
EZ	3 UF 30x50 EZ	547530	0.384
	3 UF 30x100 EZ	547531	0.526
	3 UF 30x150 EZ	547532	0.668
	3 UF 30x200 EZ	547533	0.811
	3 UF 30x300 EZ	547534	1.095
M	Description	Code	Weight Kg/ml
HDG	3 UF 30x50 HDG	548530	0.422
	3 UF 30x100 HDG	548531	0.579
	3 UF 30x150 HDG	548532	0.735
	3 UF 30x200 HDG	548533	0.892
	3 UF 30x300 HDG	548534	1.205
M	Description	Code	Weight Kg/ml
SS304	3 UF 30x50 SS304	549530	0.389
	3 UF 30x100 SS304	549531	0.535
	3 UF 30x150 SS304	549532	0.680
	3 UF 30x200 SS304	549533	0.825
	3 UF 30x300 SS304	549534	1.115
M	Description	Code	Weight Kg/ml
SS316	3 UF 30x50 SS316	550530	0.389
	3 UF 30x100 SS316	550531	0.535
	3 UF 30x150 SS316	550532	0.680
	3 UF 30x200 SS316	550533	0.825
	3 UF 30x300 SS316	550534	1.115

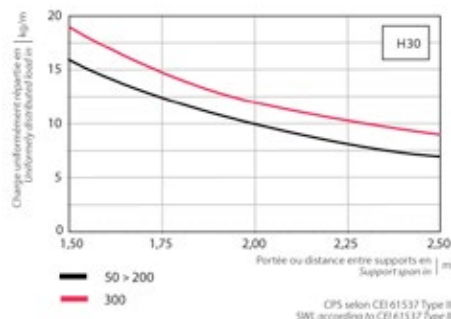
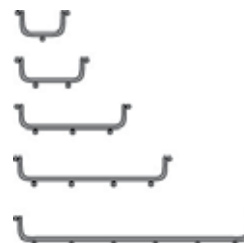
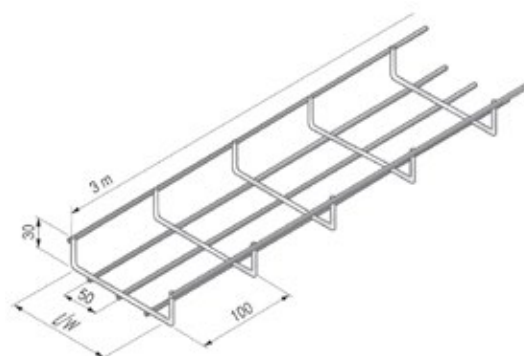

UNIFIL (UF)

UF H54

54 mm 50-600mm

M	Description	Code	Weight Kg/ml
EZ	3 UF 54x50 EZ	547535	0.620
	3 UF 54x100 EZ	547536	0.762
	3 UF 54x150 EZ	547537	0.905
	3 UF 54x200 EZ	547538	1.047
	3 UF 54x300 EZ	547539	2.034
	3 UF 54x400 EZ	547540	2.811
	3 UF 54x500 EZ	547541	3.314
	3 UF 54x600 EZ	547542	3.817

M	Description	Code	Weight Kg/ml
HDG	3 UF 54x50 HDG	548535	0.682
	3 UF 54x100 HDG	548536	0.838
	3 UF 54x150 HDG	548537	0.995
	3 UF 54x200 HDG	548538	1.152
	3 UF 54x300 HDG	548539	2.238
	3 UF 54x400 HDG	548540	3.093
	3 UF 54x500 HDG	548541	3.646
	3 UF 54x600 HDG	548542	4.199

M	Description	Code	Weight Kg/ml
SS304	3 UF 54x50 SS304	549535	0.630
	3 UF 54x100 SS304	549536	0.775
	3 UF 54x150 SS304	549537	0.920
	3 UF 54x200 SS304	549538	1.065
	3 UF 54x300 SS304	549539	2.072
	3 UF 54x400 SS304	549540	2.515
	3 UF 54x500 SS304	549541	2.958
	3 UF 54x600 SS304	549542	3.401

M	Description	Code	Weight Kg/ml
SS316	3 UF 54x50 SS316	550535	0.630
	3 UF 54x100 SS316	550536	0.775
	3 UF 54x150 SS316	550537	0.920
	3 UF 54x200 SS316	550538	1.065
	3 UF 54x300 SS316	550539	2.072
	3 UF 54x400 SS316	550540	2.515
	3 UF 54x500 SS316	550541	2.958
	3 UF 54x600 SS316	550542	3.401

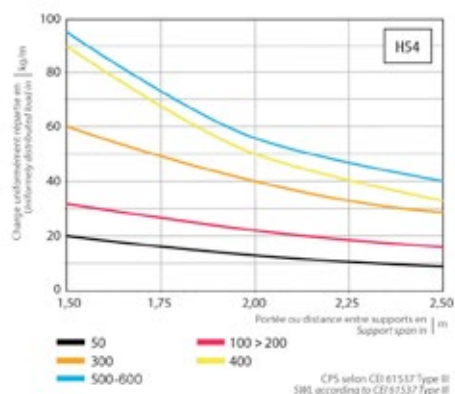
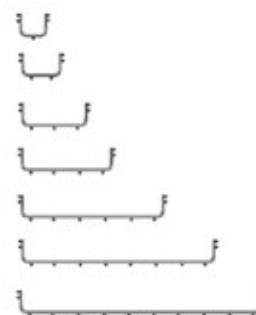
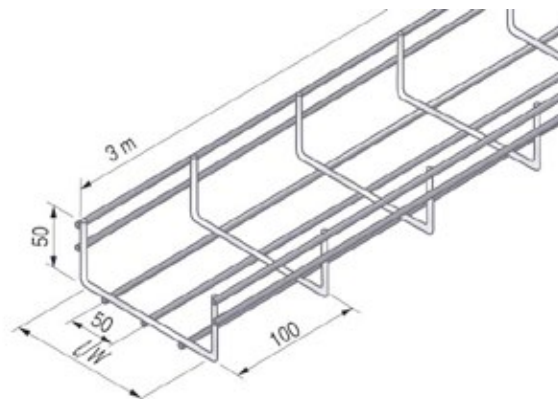

UNIFIL (UF)

UF H105

105 mm 100 ▶ 600 mm

M	Description	Code	Weight Kg/ml
EZ	3 UF 105x100 EZ	547595	1.047
	3 UF 105x200 EZ	547596	2.034
	3 UF 105x300 EZ	547597	2.811
	3 UF 105x400 EZ	547598	3.314
	3 UF 105x500 EZ	547599	3.817
	3 UF 105x600 EZ	547600	4.320

M	Description	Code	Weight Kg/ml
HDG	3 UF 105x100 HDG	548595	1.152
	3 UF 105x200 HDG	548596	2.238
	3 UF 105x300 HDG	548597	3.093
	3 UF 105x400 HDG	548598	3.646
	3 UF 105x500 HDG	548599	4.199
	3 UF 105x600 HDG	548600	4.752

M	Description	Code	Weight Kg/ml
SS304	3 UF 105x100 SS304	549595	1.065
	3 UF 105x200 SS304	549596	2.072
	3 UF 105x300 SS304	549597	2.515
	3 UF 105x400 SS304	549598	2.958
	3 UF 105x500 SS304	549599	3.401
	3 UF 105x600 SS304	549600	3.844

M	Description	Code	Weight Kg/ml
SS316	3 UF 105x100 SS316	550595	1.065
	3 UF 105x200 SS316	550596	2.072
	3 UF 105x300 SS316	550597	2.515
	3 UF 105x400 SS316	550598	2.958
	3 UF 105x500 SS316	550599	3.401
	3 UF 105x600 SS316	550600	3.844

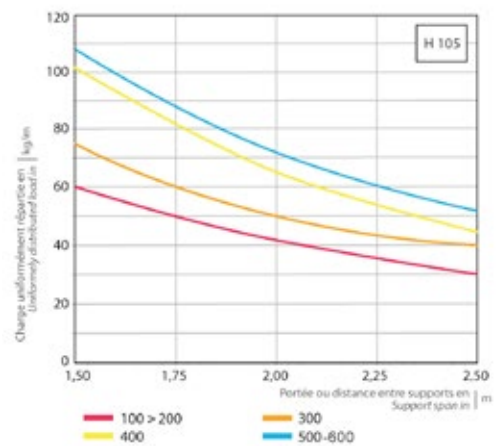
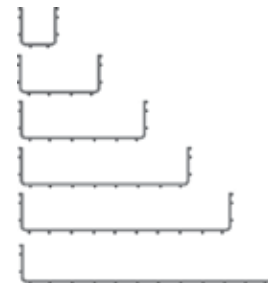
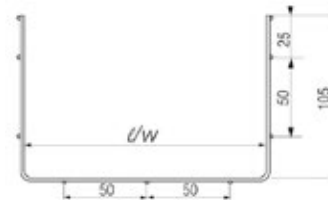
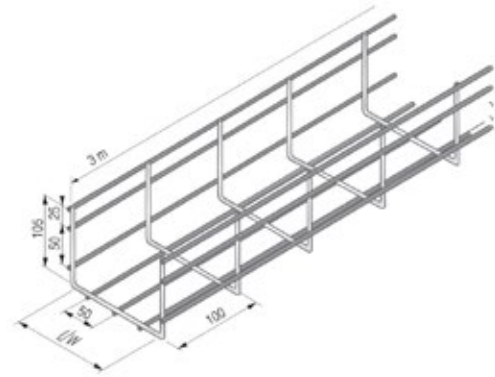

CPS selon CEI 61537 Type III  
SWL according to CEI 61537 Type III



UF TELEX, UF 70, UFG

Specific mesh trays shaped to be directly fixed on wall, floor or ceiling with or without brackets

UF TELEX H35

35 mm 35 mm

	M	Description	Code	Weight Kg/ml
EZ	3	UFT 35x35 EZ	547298	0.300
	M	Description	Code	Weight Kg/ml
HDG	3	UFT 35x35 HDG	548298	0.320
	M	Description	Code	Weight Kg/ml
SS304	3	UFT 35x35 SS304	549298	0.350

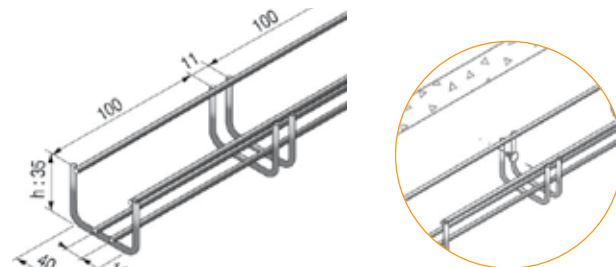

Exclusive:

- 2 wires at the bottom to allow direct bracket / floor assembly
- 2 wires at the side every 400 mm for direct wall assembly (with Ø 6 or 8 mm hardware)
- No supports required

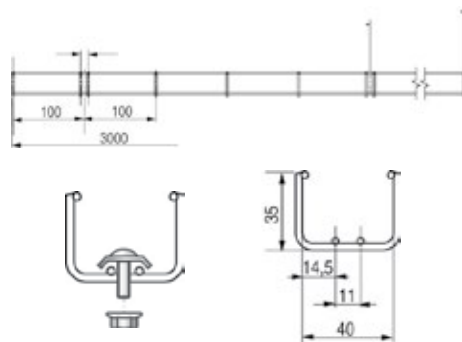

UF 70 H30

30 mm 70 mm

	M	Description	Code	Weight Kg/ml
EZ	3	UF 30x70 EZ	547299	0.530
	M	Description	Code	Weight Kg/ml
HDG	3	UF 30x70 HDG	548299	0.590
	M	Description	Code	Weight Kg/ml
SS304	3	UF 30x70 SS304	549299	0.510
	M	Description	Code	Weight Kg/ml
SS316	3	UF 30x70 SS316	550299	0.510

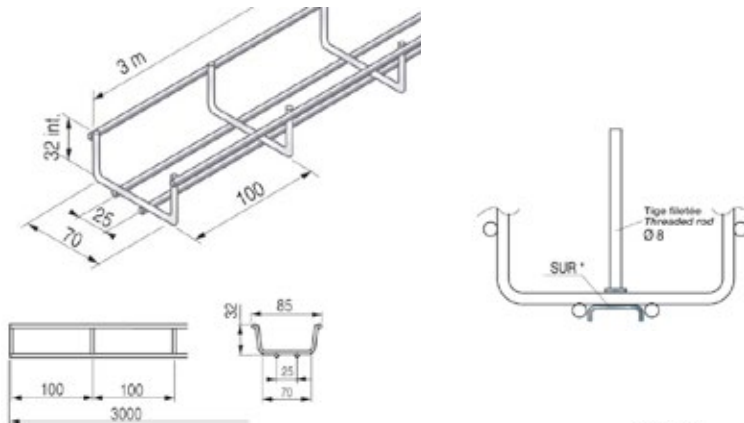

UF 70 H54

54 mm 70 mm

	M	Description	Code	Weight Kg/ml
EZ	3	UF 54x70 EZ	547300	0.738
	M	Description	Code	Weight Kg/ml
HDG	3	UF 54x70 HDG	548300	0.812
	M	Description	Code	Weight Kg/ml
SS304	3	UF 54x70 SS304	549300	0.750
	M	Description	Code	Weight Kg/ml
SS316	3	UF 54x70 SS316	550300	0.750

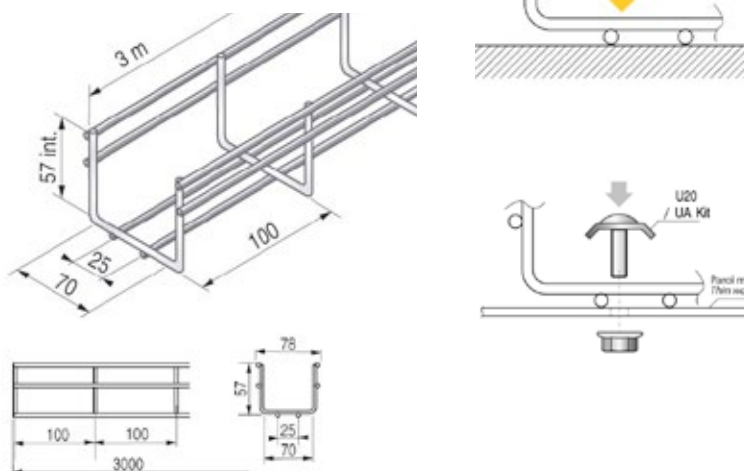

UF TELEX, UF 70, UFG

UFG 40X60

40 mm 60 mm

M	Description	Code	Weight Kg/ml
EZ	3 UFG 40x60 MINI EZ	547230	0.313

Time saving and safety:

- Stable assembly directly on wall, floor or ceiling
- No supports required
- Fasten with  $\varnothing$  6 or 8 mm hardware directly through the double wire every 400 mm
- Coupling with ERU3 or KU20

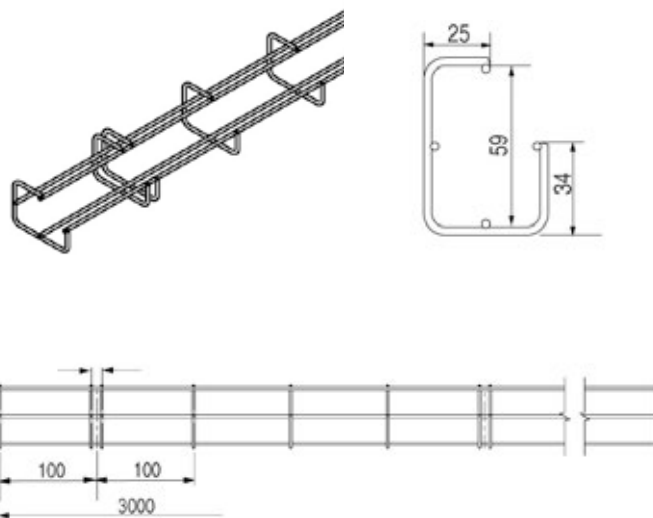
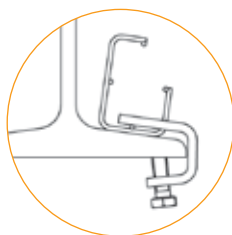
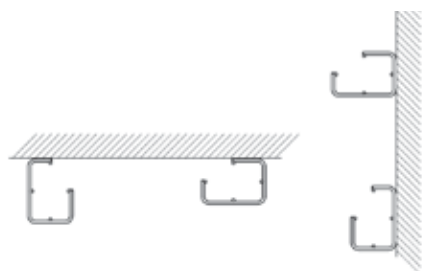

UFG 50

50 mm 100 ▶ 200 mm

M	Description	Code	Weight Kg/ml
EZ	3 UFG 50x100 EZ	547236	0.811
	3 UFG 50x200 EZ	547238	1.492

M	Description	Code	Weight Kg/ml
H DG	3 UFG 50x100 HDG	548236	0.892
	3 UFG 50x200 HDG	548238	1.204

M	Description	Code	Weight Kg/ml
SS316	3 UFG 50x100 SS316	550236	0.825

Direct fixing on wall or ceiling without brackets

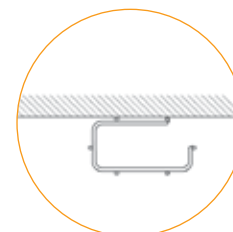
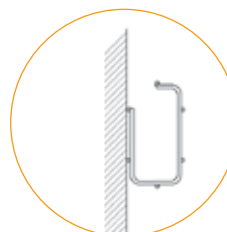
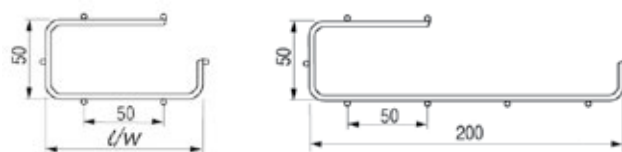

UFG 100

100 mm 150 mm

M	Description	Code	Weight Kg/ml
EZ	3 UFG 100x150 EZ	547601	1.492

M	Description	Code	Weight Kg/ml
H DG	3 UFG 100x150 HDG	548601	1.205

Direct fixing on wall or ceiling without brackets

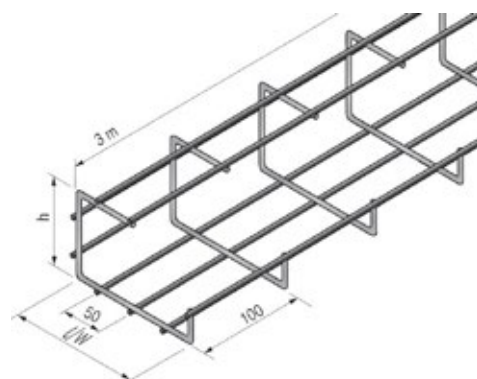
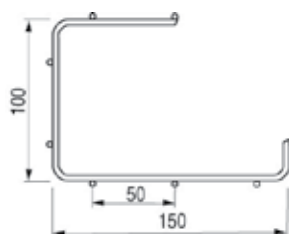
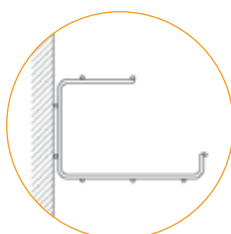

ACCESSORIES FOR STRAIGHT OR CURVED ASSEMBLY

ERU 3 COUPLERS

30 ▶ 105 mm 50 ▶ 600 mm

Multifunctional coupler without bolts:

- Coupling
- Earth bolt / connector support
- Use with Ø 6-8 mm threaded rods for ceiling suspension
- Also suitable direct wall-mounted installation

Benefits:

- High resistance thanks to its thicker gauge
- Safety and rapidity thanks to its backstop tabs
- Easy locking with a screwdriver

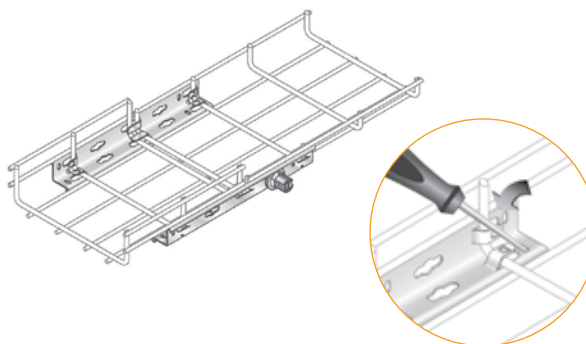
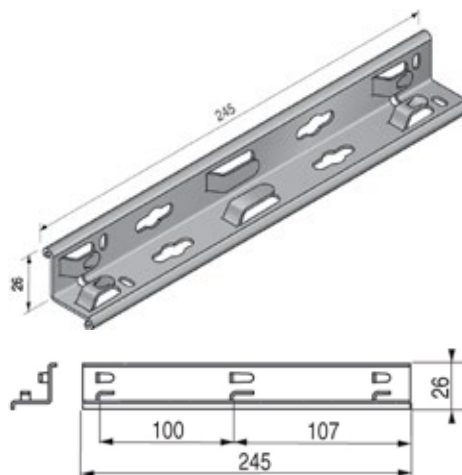

	P	Description	Code	Weight Kg/p
G	50	ERU3 G	552136	0.230
	P	Description	Code	Weight Kg/p
ZM	50	ERU3 ZM	553136	0.230
	P	Description	Code	Weight Kg/p
SS304	50	ERU3 SS304	554136	0.153
	P	Description	Code	Weight Kg/p
SS316	50	ERU3 SS316	555136	0.191

RAPIDFIL COUPLERS

54/105 mm H54 : 50 ▶ 200 mm / H105 : 100 mm

Installation time reduced by 50%!

- No bolts, no tools for convenience
- Removable and re-usable, even in case of wall assembly
- Electrical continuity in compliance with IEC 61537 international standard
- As resistant as a traditional bolted coupler
- Easier management: reduces the number of pieces on site

	P	Description	Code	Weight Kg/p
G	50	RAPIDFIL G	552030	0.096
	P	Description	Code	Weight Kg/p
ZM	50	RAPIDFIL ZM	553030	0.096

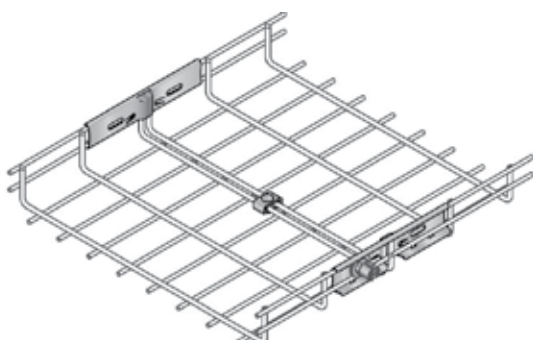
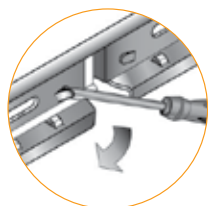
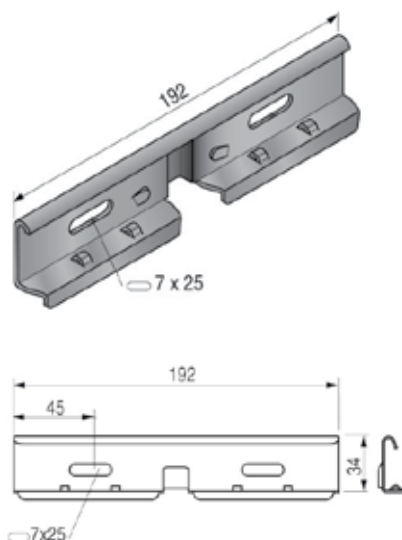

ACCESSORIES FOR STRAIGHT OR CURVED ASSEMBLY

U-LINK COUPLERS

54 mm 50 ▶ 300 mm

P	Description	Code	Weight Kg/p
G	25 U-LINK 54x50 G	552161	0.026
	25 U-LINK 54x100 G	552162	0.038
	25 U-LINK 54x150 G	552163	0.050
	25 U-LINK 54x200 G	552164	0.061
	25 U-LINK 54x300 G	552165	0.098
P	Description	Code	Weight Kg/p
SS304	25 U-LINK 54x50 SS304	554161	0.020
	25 U-LINK 54x100 SS304	554162	0.030
	25 U-LINK 54x150 SS304	554163	0.040
	25 U-LINK 54x200 SS304	554164	0.049
	25 U-LINK 54x300 SS304	554165	0.098

**U-LINK coupler for easy, quick and safe installation!**

- Easy assembly without bolts and tools
- The coupler can be removed and re-used
- Safe for cables with a design completely covering the junction between mesh trays
- Compatible with all our range of accessories

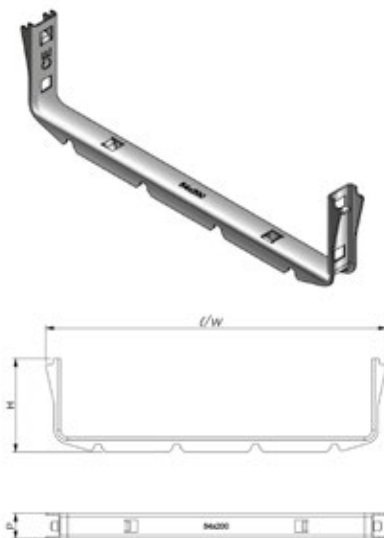

EKT COUPLERS

30 / 54 / 105 mm H30: 100 ▶ 300 mm / H54: 100 ▶ 200 mm / H105: 100 mm

P	Description	Code	Weight Kg/p
G	50 EKT G	552137	0.110
P	Description	Code	Weight Kg/p
ZM	50 EKT ZM	553137	0.110

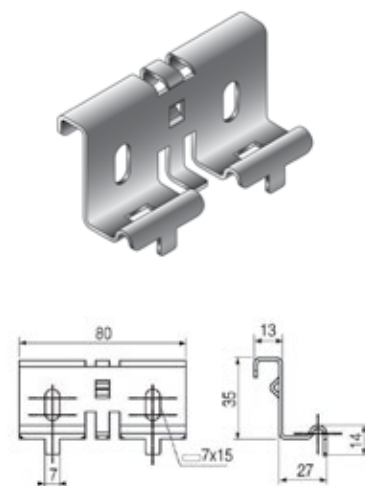
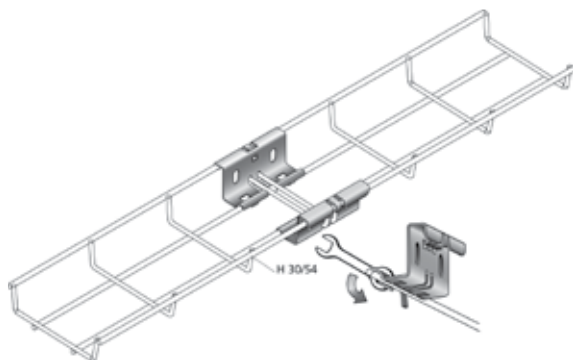

EDU COUPLERS

54 ▶ 105 mm 50 ▶ 600 mm

P	Description	Code	Weight Kg/p
G	50 EDU G	552117	0.089
P	Description	Code	Weight Kg/p
HDG	50 EDU HDG	553117	0.098
P	Description	Code	Weight Kg/p
SS316	50 EDU SS316	555117	0.093

Fasten each coupler with 1 set of 1xTRCC 6x20 bolt + 1xU20 fixing clamp

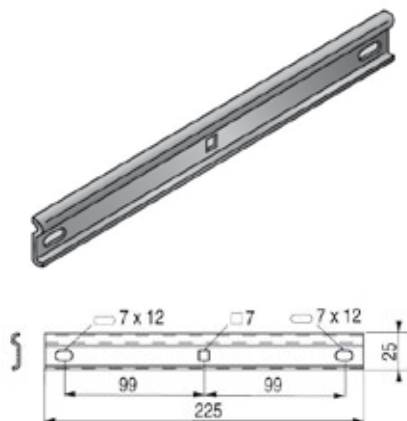
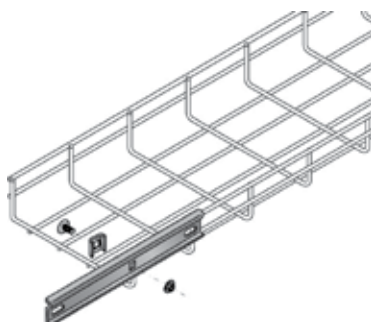

ACCESSORIES FOR STRAIGHT OR CURVED ASSEMBLY

KU20 COUPLERS

30 ▶ 105 mm

For straight, curved or offside sections assembly

- Time saving: more than 40% compared to traditional assembly
- Safe and re-usable. Just tighten the pre-assembled nut and your mesh trays are assembled
- For easier management, the number of references on site is divided by 2 compared to traditional assembly

	P	Description	Code	Weight Kg/p
EZ	50	KU20 EZ	552134	0.020
	P	Description	Code	Weight Kg/p
GM	50	KU20 GM	553134	0.020
	P	Description	Code	Weight Kg/p
SS304	50	KU20 SS304	554134	0.020
	P	Description	Code	Weight Kg/p
SS316	50	KU20 SS316	555134	0.020

Recommended to reinforce tray bottom for widths greater than 300 mm

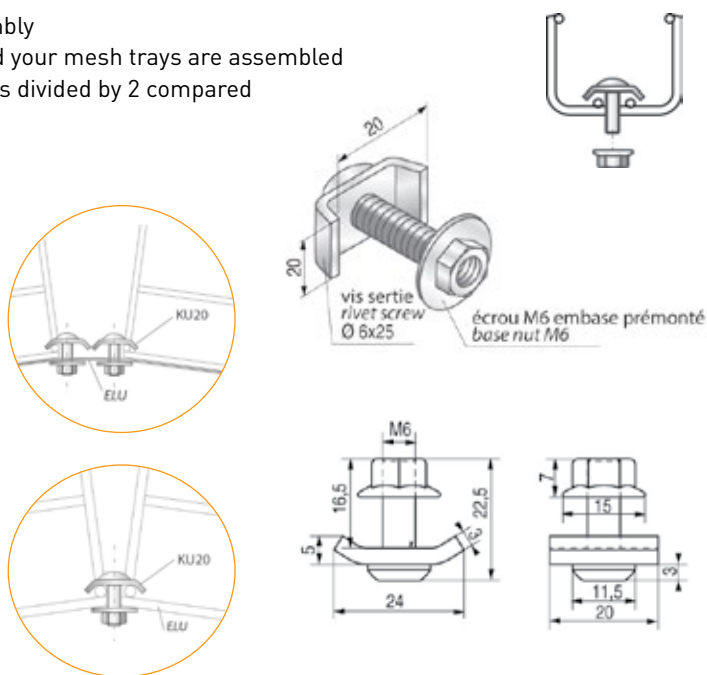

U20-U30 KIT

30 ▶ 105 mm

Couplers for assembly of straight sections, bends, tees and crosses

	P	Description	Code	Weight Kg/p
EZ	50	KIT U20/U30 EZ	552050	0.024
	P	Description	Code	Weight Kg/p
GM	50	KIT U20/U30 GM	553050	0.032
	P	Description	Code	Weight Kg/p
SS304	50	KIT U20/U30 SS304	554050	0.024
	P	Description	Code	Weight Kg/p
SS316	50	KIT U20/U30 SS316	555050	0.024

Only 1 kit for any straight or curved assembly  
Recommended to reinforce tray bottom for widths greater than 300 mm

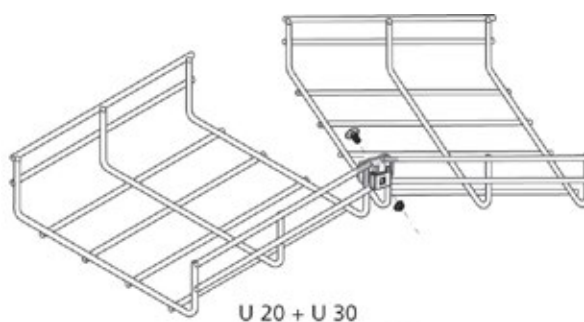
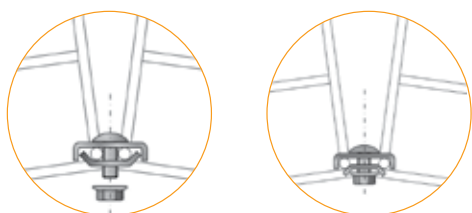
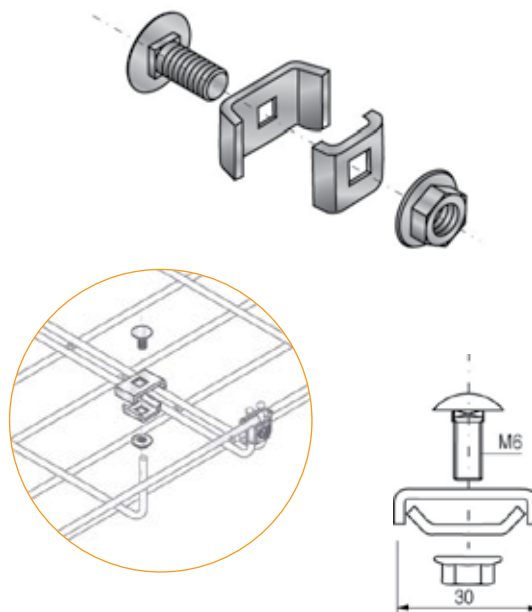



ACCESSORIES FOR STRAIGHT OR CURVED ASSEMBLY

U20-U30 COUPLERS

 30 ▶ 105 mm

Couplers for assembly of straight sections, bends, tees and crosses

	P	Description	Code	Weight Kg/Bag
EZ	50	U20 EZ	552042	0.600
	50	U30 EZ	552043	1.500
	P	Description	Code	Weight Kg/Bag
GM	50	U20 GM	553042	0.900
	50	U30 GM	553043	1.500
	P	Description	Code	Weight Kg/Bag
SS304	50	U20 SS304	554042	0.465
	50	U30 SS304	554043	0.774
	P	Description	Code	Weight Kg/Bag
SS316	50	U20 SS316	555042	0.465
	50	U30 SS316	555043	0.774

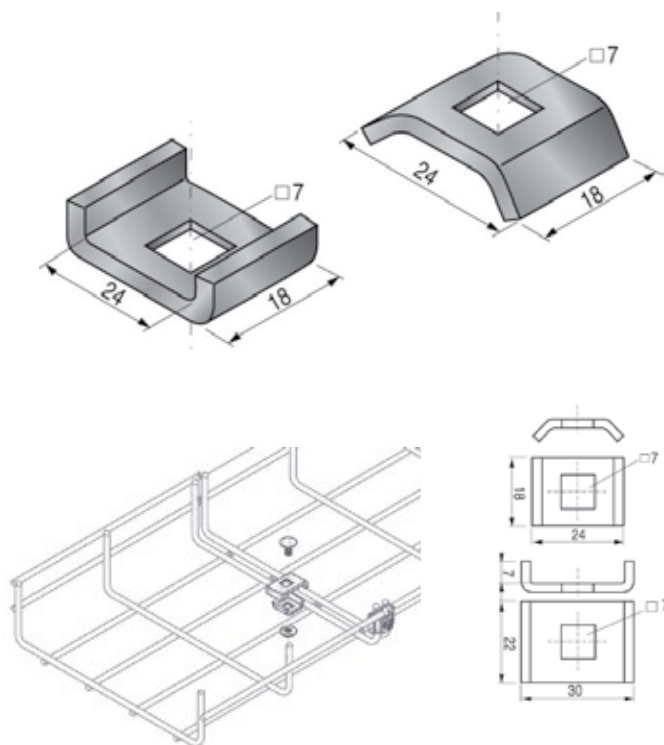

Recommended to reinforce tray bottom for widths greater than 300 mm

- 1 x TRCC 6x20 bolt required separately
- Alternative couplers: **KU20** or **KIT U20-U30**

UA COUPLERS

 30 ▶ 105 mm

Couplers for assembly of straight sections, bends, tees and crosses

	P	Description	Code	Weight Kg/p
EZ	50	UA EZ	552121	0.017

- Alternative coupler: **KIT U20-U30**
- Recommended to reinforce tray bottom for widths greater than 300 mm

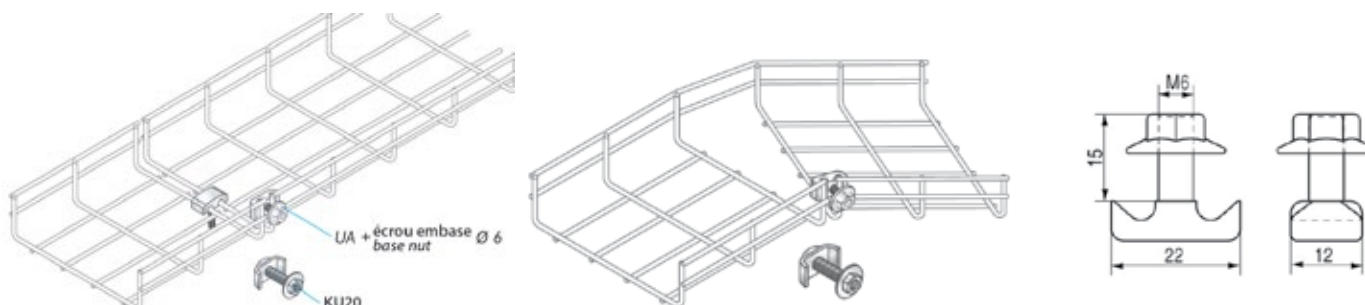
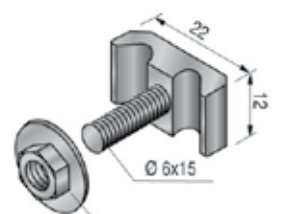



ACCESSORIES FOR STRAIGHT OR CURVED ASSEMBLY

MTCA 4 COUPLER FOR BENDS

30/54/105 mm H30 : <300 mm / H54 : <200 mm / H105 : <150 mm



P	Description	Code	Weight Kg/p
SS 50	MTCA 4 SS	713615	0.010

NEW !

Assembly without bolts and tools  
Smooth adjustment of angles directly on site  
for horizontal or vertical bends

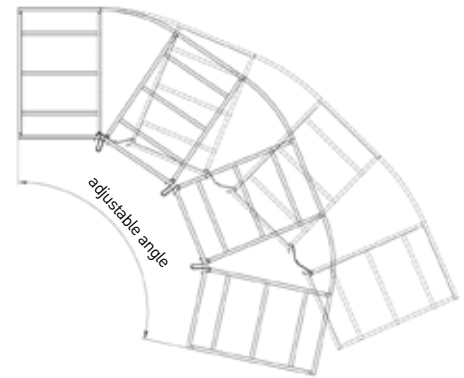
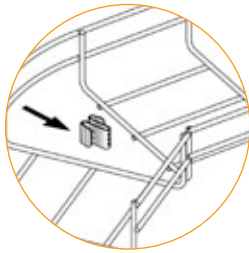

ELU COUPLERS

30 ▶ 105 mm 50 ▶ 600 mm

P	Description	Code	Weight Kg/Bag
EZ 25	ELU 300 EZ	552038	0.080
25	ELU 600 EZ	552044	0.170
25	ELU 1200 EZ	552045	0.320
P	Description	Code	Weight Kg/Bag
HdG 25	ELU 300 HdG	553038	0.090
25	ELU 600 HdG	553044	0.200
25	ELU 1200 HdG	553045	0.370
P	Description	Code	Weight Kg/Bag
SS304 25	ELU 300 SS304	554038	0.080
25	ELU 600 SS304	554044	0.200
25	ELU 1200 SS304	554045	0.370
P	Description	Code	Weight Kg/Bag
SS316 25	ELU 300 SS316	555038	0.063
1	ELU 600 SS316	555044	0.200
1	ELU 1200 SS316	555045	0.370

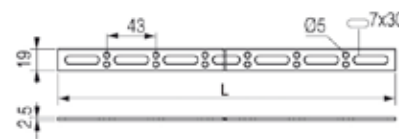
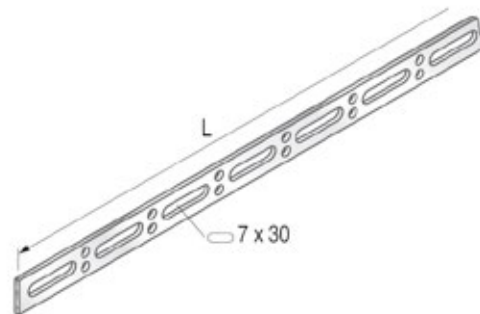

- Bendable coupler
- Large adjustment range
- Safe assembly
- Same applications as **KU20**

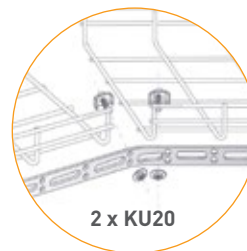

ACCESSORIES FOR STRAIGHT OR CURVED ASSEMBLY

AKT COUPLER

30 ▶ 105 mm

P	Description	Code	Weight Kg/p
ZM	100 AKT ZM	553138	0.035

Easily locked with a plier

- Also possible to lock with one TRCC M6x20 bolt

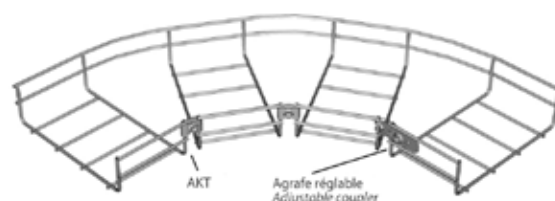
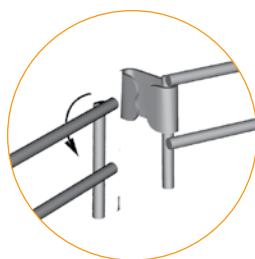
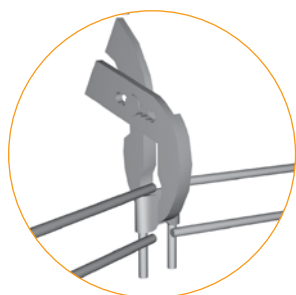

ARKT COUPLER

Adjustable coupler for angle adjustment

P	Description	Code	Weight Kg/p
ZM	10 ARKT ZM	553139	0.045

Delivered with one TRCC M6x15 bolt

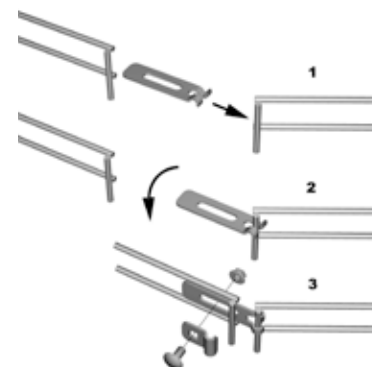
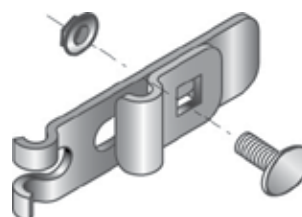

U40 SUSPENSION CLAMPS

30 ▶ 105 mm 100 ▶ 600 mm

Multifunctional and useful for small radius or cut bends

(see page 327 "Assembly of small radius")

P	Description	Code	Weight Kg/p	daN
G	50 CLAMP U40 G	552032	0.036	100
GM	50 CLAMP U40 GM	553032	0.036	100
SS304	50 CLAMP U40 SS304	554032	0.040	100
SS316	50 CLAMP U40 SS316	555032	0.036	100

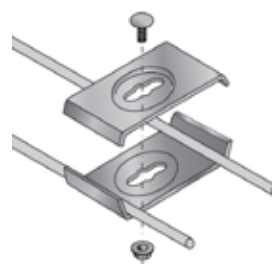
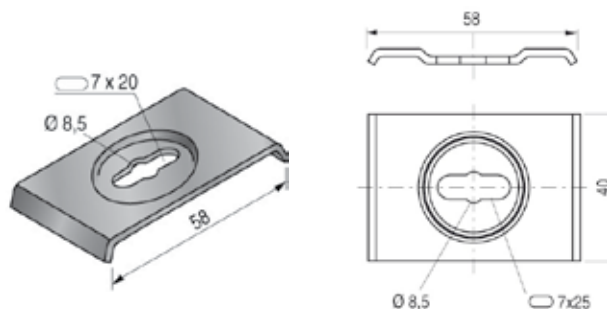

- Suspension clamp: use a Ø 6-8 mm threaded rod + 2 HE M6/M8 nuts
- Small radius bends: fasten with one TRCC M6x20 bolt

MULTIFUNCTIONAL COUPLER

T25/50

54/105 mm H54 : 50 ▶ 200 mm / H105 : 100 mm

6 functions for a single piece requiring no bolts!

1. Suspension clamp
2. Lighting support
3. Earth bolt support
4. Wall bracket for small widths
5. Support for box and other small equipment
6. Drop out together with an 8 mm pipe clamp

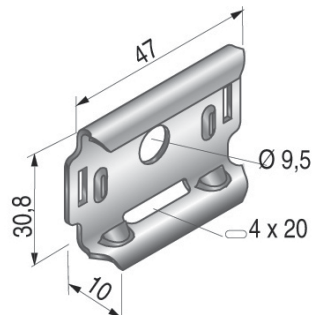

	P	Description	Code	Weight Kg/p
G	50	CLIPS T25/50 G	552129	0.020
	P	Description	Code	Weight Kg/p
ZM	50	CLIPS T25/50 ZM	556129	0.019

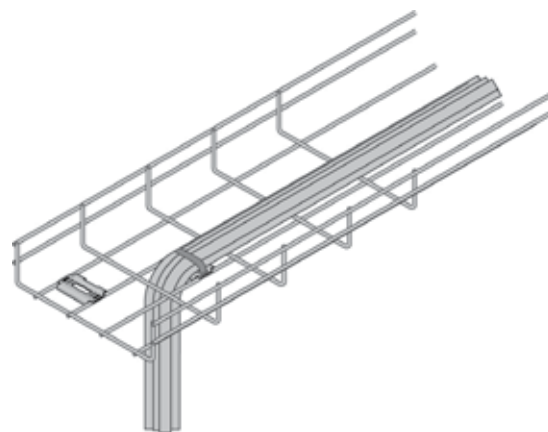
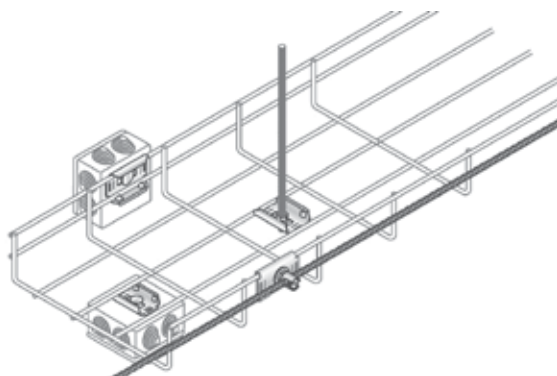
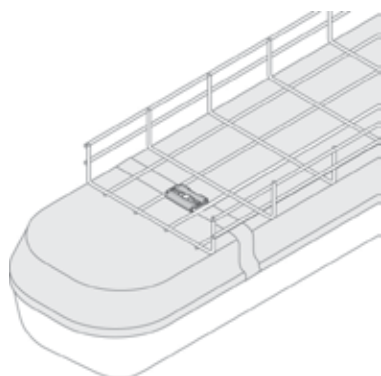
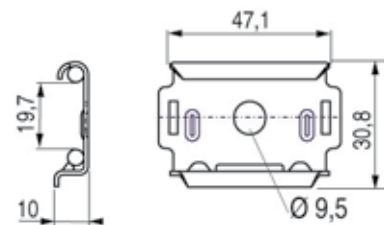

COVERS, COVER CLIPS AND DIVIDERS

MESH TRAY RIBBED COVERS

30 ▶ 105 mm 50 ▶ 600 mm

M	Description	Code	Weight Kg/ml	W. mm
G	3 CO UF 50 G	547050	0.342	74
	3 CO UF 70 G	547058	0.390	86
	3 CO UF 100 G	547051	0.540	124
	3 CO UF 150 G	547052	0.734	174
	3 CO UF 200 G	547053	0.930	224
	3 CO UF 300 G	547054	1.990	325
	3 CO UF 400 G	547055	3.430	425
	3 CO UF 500 G	547056	4.210	525
	3 CO UF 600 G	547057	5.000	625

M	Description	Code	Weight Kg/ml	W. mm
HDG	3 CO UF 50 HDG	548050	0.450	74
	3 CO UF 70 HDG	548058	0.513	86
	3 CO UF 100 HDG	548051	0.710	124
	3 CO UF 150 HDG	548052	0.969	174
	3 CO UF 200 HDG	548053	1.228	224
	3 CO UF 300 HDG	548054	2.190	325
	3 CO UF 400 HDG	548055	3.773	425
	3 CO UF 500 HDG	548056	4.637	525
	3 CO UF 600 HDG	548057	5.500	625



M	Description	Code	Weight Kg/ml	W. mm
SS304	3 CO UF 50 SS304	549050	0.540	74
	3 CO UF 70 SS304	549058	0.650	85
	3 CO UF 100 SS304	549051	0.902	124
	3 CO UF 150 SS304	549052	1.222	174
	3 CO UF 200 SS304	549053	1.542	224
	3 CO UF 300 SS304	549054	2.182	324
	3 CO UF 400 SS304	549055	3.528	425
	3 CO UF 500 SS304	549056	4.328	525
	3 CO UF 600 SS304	549057	5.128	625

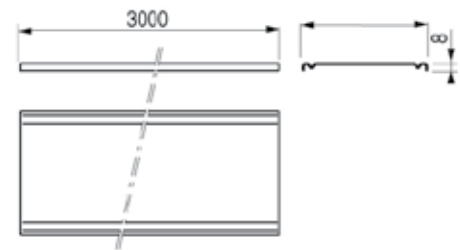

M	Description	Code	Weight Kg/ml	W. mm
SS316	3 CO UF 50 SS316	550050	0.553	74
	3 CO UF 70 SS316	550058	0.650	85
	3 CO UF 100 SS316	550051	0.902	124
	3 CO UF 150 SS316	550052	1.222	174
	3 CO UF 200 SS316	550053	1.542	224
	3 CO UF 300 SS316	550054	2.182	324
	3 CO UF 400 SS316	550055	3.528	425
	3 CO UF 500 SS316	550056	4.328	525
	3 CO UF 600 SS316	550057	5.030	623

Use 8 clips every 3 metres

COVERS, COVER CLIPS AND DIVIDERS

UF 30 COVER CLIPS

30 mm 50 ▶ 300 mm

P	Description	Code	Weight Kg/p
SS314	20 CLIPS UF H30 SS	553058	0.004

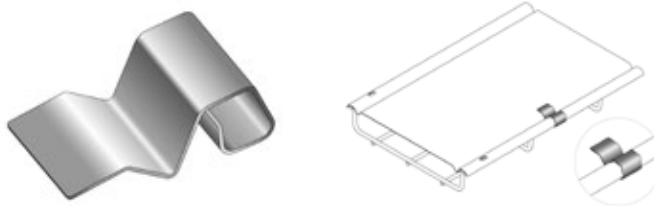

UF 54-105 COVER CLIPS

54 ▶ 105 mm 50 ▶ 600 mm

P	Description	Code	Weight Kg/Bag
SS304	20 CLIPS UF H54-105 SS	554041	0.114

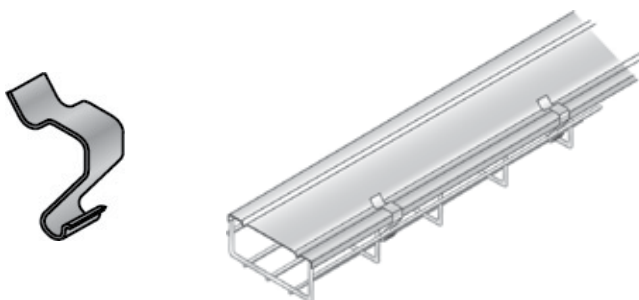

LPSU UNIVERSAL DIVIDERS

30 ▶ 105 mm

M	Description	Code	Weight Kg/ml	H. mm
G	3 LPSU 24 G	400060	0.330	24
	3 LPSU 48 G	400061	0.470	48
	3 LPSU 96 G	400062	0.992	96

M	Description	Code	Weight Kg/ml	H. mm
HDG	3 LPSU 24 HDG	548060	0.450	24
	3 LPSU 48 HDG	548061	0.500	48
	3 LPSU 96 HDG	548062	1.013	96

M	Description	Code	Weight Kg/ml	H. mm
SS304	3 LPSU 24 SS304	549060	0.300	24
	3 LPSU 48 SS304	549061	0.470	48
	3 LPSU 96 SS304	549062	0.950	96

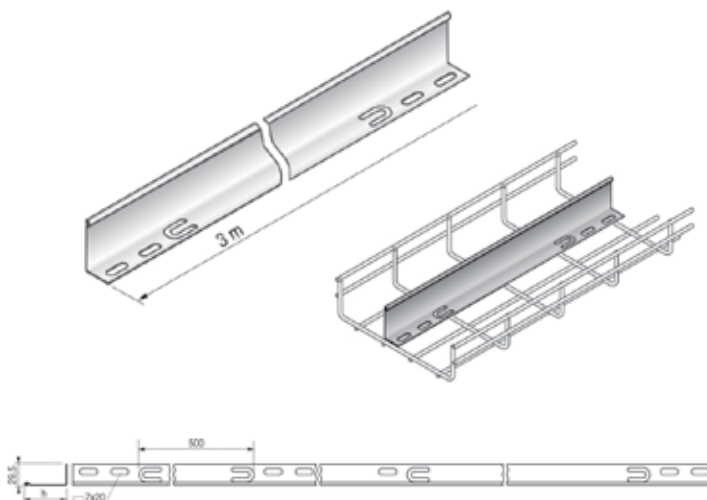

LPSJ DIVIDER JUNCTIONS

P	Description	Code	Weight Kg/p
SS304	25 LPSJ SS304	554143	0.014

For LPSU universal dividers

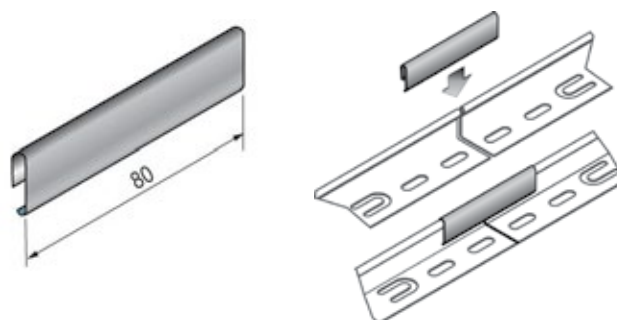

CEILING MOUNTING ACCESSORIES

S100U LONG CHANNELS

M	Description	Code	Weight Kg/ml	Th. mm
G	1 S100U 1M G	747107	1.190	2.00
	2 S100U 2M G	747110	1.190	2.00
	3 S100U 3M G	747111	1.190	2.00
M	Description	Code	Weight Kg/ml	Th. mm
ZM	1 S100U 1M ZM	748107	1.190	2.00
	2 S100U 2M ZM	748110	1.190	2.00
	3 S100U 3M ZM	748111	1.190	2.00
M	Description	Code	Weight Kg/ml	Th. mm
SS316	1 S100U 1M SS316	750107	1.190	2.00
	2 S100U 2M SS316	750110	1.190	2.00
	3 S100U 3M SS316	750111	3.580	2.00

Use TRCC M6x12 bolt or **AGRAFTOL** for mounting the trays

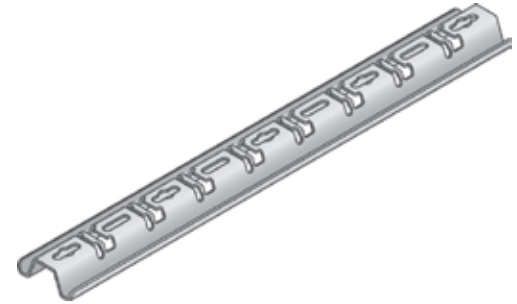

S100U SHORT CHANNELS

P	Description	Code	Weight Kg/p	Th. mm
G	10 S100U 200 G	747101	0.230	2.00
	10 S100U 250 G	747102	0.280	2.00
	10 S100U 350 G	747103	0.390	2.00
	10 S100U 450 G	747104	0.490	2.00
	10 S100U 550 G	747105	0.610	2.00
	10 S100U 650 G	747106	0.750	2.00
P	Description	Code	Weight Kg/p	Th. mm
ZM	10 S100U 200 ZM	748101	0.230	2.00
	10 S100U 250 ZM	748102	0.280	2.00
	10 S100U 350 ZM	748103	0.390	2.00
	10 S100U 450 ZM	748104	0.490	2.00
	10 S100U 550 ZM	748105	0.610	2.00
	10 S100U 650 ZM	748106	0.750	2.00
P	Description	Code	Weight Kg/p	Th. mm
SS316	20 S100U 200 SS316	750101	0.230	2.00
	20 S100U 250 SS316	750102	0.280	2.00
	20 S100U 350 SS316	750103	0.390	2.00
	20 S100U 450 SS316	750104	0.490	2.00
	20 S100U 550 SS316	750105	0.610	2.00
	20 S100U 650 SS316	750106	0.750	2.00

Suitable for use with **AGRAFTOL**

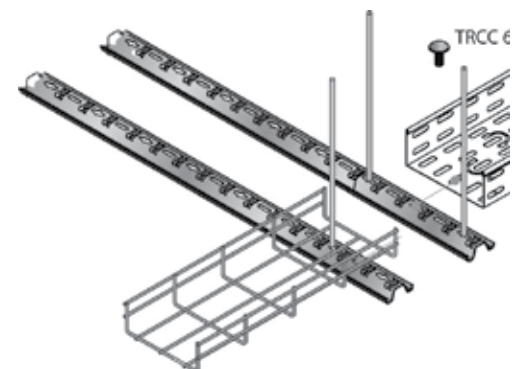
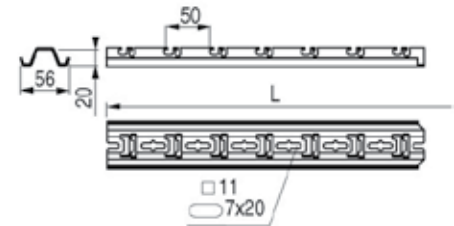



CEILING MOUNTING ACCESSORIES

S100U SHORT CHANNELS WITH DOUBLE EDGE SLOTS

30 ▶ 105 mm 50 ▶ 600 mm

P	Description	Code	Weight Kg/p	Th. mm	L. mm
G	10 S100U 100 G	747201	0.260	2.00	204
	10 S100U 150 G	747202	0.320	2.00	254
	10 S100U 200 G	747203	0.380	2.00	304
	10 S100U 300 G	747204	0.500	2.00	404
	10 S100U 400 G	747205	0.620	2.00	504
	10 S100U 500 G	747206	0.740	2.00	604
	10 S100U 600 G	747207	0.860	2.00	704

P	Description	Code	Weight Kg/p	Th. mm	L. mm
ZM	10 S100U 100 ZM	748201	0.260	2.00	204
	10 S100U 150 ZM	748202	0.320	2.00	254
	10 S100U 200 ZM	748203	0.380	2.00	304
	10 S100U 300 ZM	748204	0.500	2.00	404
	10 S100U 400 ZM	748205	0.620	2.00	504
	10 S100U 500 ZM	748206	0.740	2.00	604
	10 S100U 600 ZM	748207	0.860	2.00	704

P	Description	Code	Weight Kg/p	Th. mm	L. mm
SS316	10 S100U 100 SS316	750201	0.260	2.00	204
	10 S100U 150 SS316	750202	0.320	2.00	254
	10 S100U 200 SS316	750203	0.380	2.00	304
	10 S100U 300 SS316	750204	0.500	2.00	404
	10 S100U 400 SS316	750205	0.620	2.00	504
	10 S100U 500 SS316	750206	0.740	2.00	604
	10 S100U 600 SS316	750207	0.860	2.00	704

Use TRCC M6x12 bolt or AGRAFTOL for mounting the trays

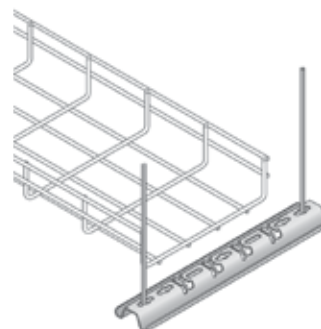
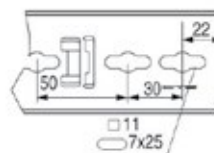
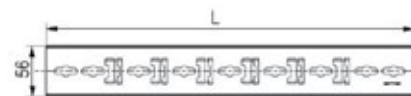
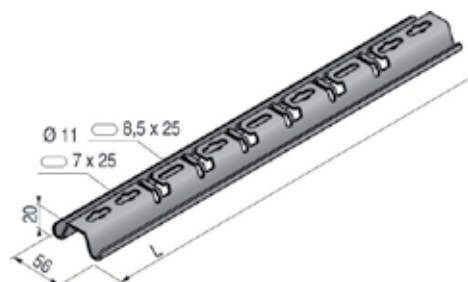

SUR BRACKETS

30 ▶ 105 mm 50 ▶ 600 mm

P	Description	Code	Weight Kg/p	Th. mm	daN
G	25 SUR G	552085	0.074	1.25	80

P	Description	Code	Weight Kg/p	Th. mm	daN
ZM	25 SUR ZM	553085	0.074	1.20	80

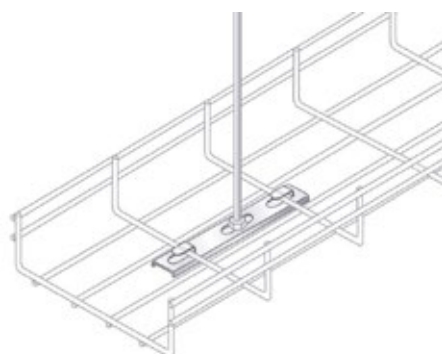
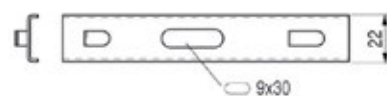
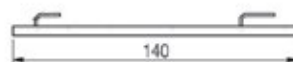
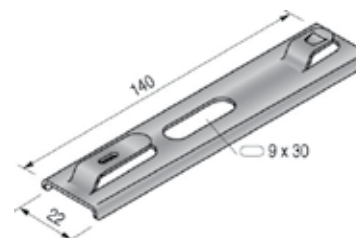

CEILING MOUNTING ACCESSORIES

SFT BRACKETS

30 ▶ 54mm 50 mm

P	Description	Code	Weight Kg/p	daN
G 25	SFT 50 - 100	747050	0.200	20
ZM 25	SFT 50 - 100	748050	0.200	20
SS316 25	SFT 50 - 100	750050	0.200	20

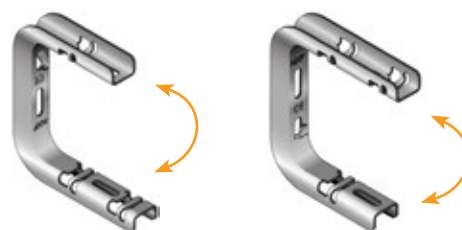

NEW !

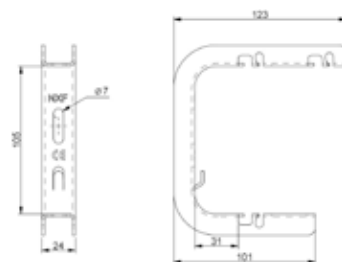

- Suitable for perforated trays and mesh trays
  - Reversible bracket for 50 and 100 mm wide cable trays
- Mount directly onto the wall or use a threaded rod for the ceiling

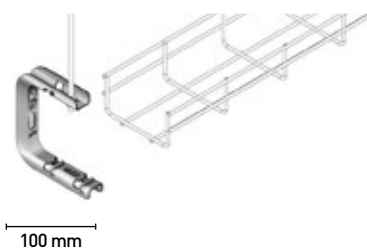
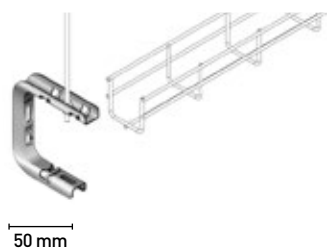

SUL 50 BRACKETS

30 ▶ 54 mm 50 mm

Central support for 50 mm wide mesh tray

Fast:

- Clip-on system
- Hands free
- No bolts
- Can be locked

Multifunctional:

- Suspension with Ø 6-8 mm threaded rod or cable
- Can be fixed directly to ceiling, wall or floor thanks to 7x25 oblong hole
- Supports other equipment

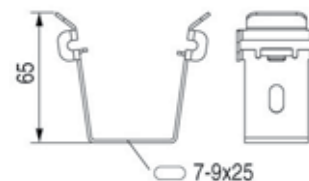
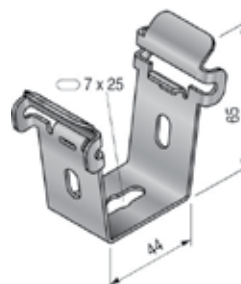

P	Description	Code	Weight Kg/p	Th. mm	daN
G 10	SUL50 G	552118	0.073	1.75	40
ZM 10	SUL50 ZM	553118	0.073	1.75	40
SS304 10	SUL50 SS304	554118	0.070	1.50	40
SS316 10	SUL50 SS316	555118	0.120	1.50	40

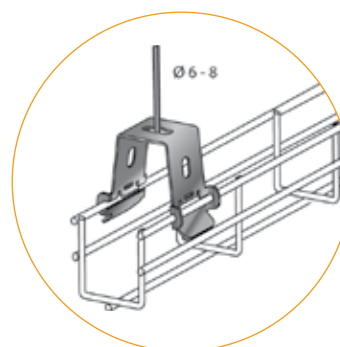

CEILING MOUNTING ACCESSORIES

UFA HANGING BRACKETS

30 ▶ 105 mm 50 ▶ 600 mm

	P	Description	Code	Weight Kg/p	daN
G	20	UFA G	552033	0.070	100
ZM	20	UFA ZM	553033	0.070	100
SS304	20	UFA SS304	554033	0.070	100
SS316	20	UFA SS316	555033	0.057	100

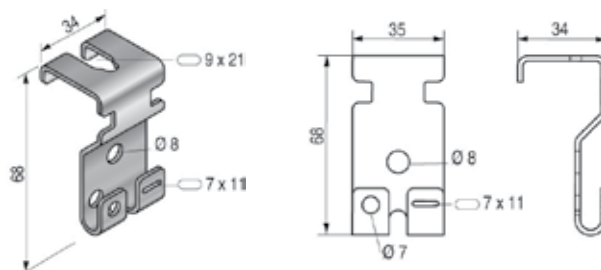

- Can be locked with one TRCC M6x30 bolt
- Hands free: the threaded rod is secured
- Can be slid into STRUT 41 channel for adjustable suspensions

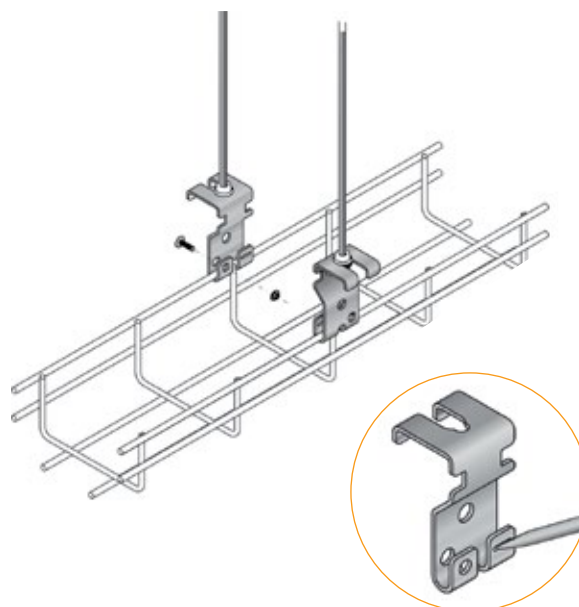
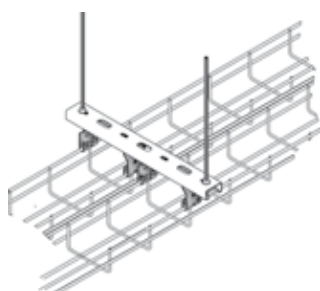
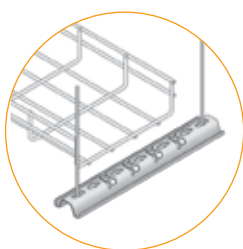

CEILING MOUNTING ACCESSORIES

SV 50 BRACKETS

30 ▶ 105 mm

	P	Description	Code	Weight Kg/p	Th. mm	daN
G	20	SV50 G	552141	0.091	1.75	30
	P	Description	Code	Weight Kg/p	Th. mm	daN
ZM	20	SV50 ZM	553141	0.059	1.75	30
	P	Description	Code	Weight Kg/p	Th. mm	daN
SS304	20	SV50 SS304	554141	0.050	1.50	30
	P	Description	Code	Weight Kg/p	Th. mm	daN
SS316	20	SV50 SS316	555141	0.050	1.50	30

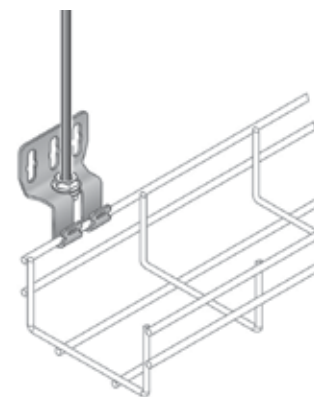

Vertical support for ceiling suspension together with Ø 6-8 mm threaded rod

- 3 adjustment positions
- Hands free: secured

U40 SUSPENSION CLAMPS

30 ▶ 105 mm 100 ▶ 600 mm

Multifunctional and useful for small radius or cut bends

(see page 327 "Assembly of small radius")

	P	Description	Code	Weight Kg/p	daN
G	50	CLAMP U40 G	552032	0.036	100
	P	Description	Code	Weight Kg/p	daN
GM	50	CLAMP U40 GM	553032	0.036	100
	P	Description	Code	Weight Kg/p	daN
SS304	50	CLAMP U40 SS304	554032	0.040	100
	P	Description	Code	Weight Kg/p	daN
SS316	50	CLAMP U40 SS316	555032	0.036	100

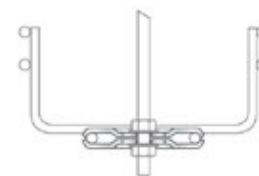
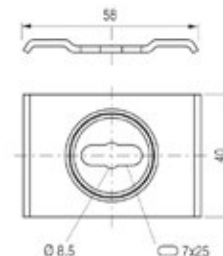
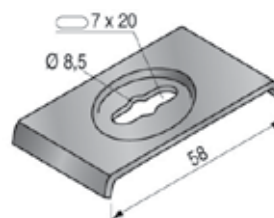

- Suspension clamp: use a Ø 6-8 mm threaded rod + 2 HE M6/M8 nuts
- Small radius bends: fasten with one TRCC M6x20 bolt

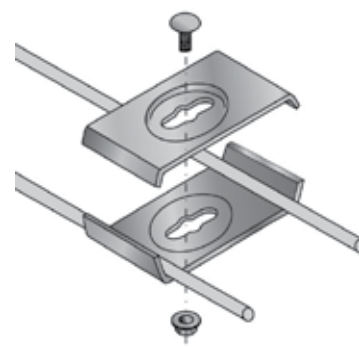

WALL AND FLOOR MOUNTING ACCESSORIES

ZUF 150 U CLIP-ON BRACKET

30 ▶ 105 mm 50 ▶ 600mm

	P	Description	Code	Weight Kg/p	Th. mm	daN
G	10	ZUF 150 U G	552147	0.140	1.75	100
	P	Description	Code	Weight Kg/p	Th. mm	daN
ZM	10	ZUF 150 U ZM	553147	0.140	1.80	100
	P	Description	Code	Weight Kg/p	Th. mm	daN
SS316	10	ZUF 150 U SS316	555147	0.120	1.50	100

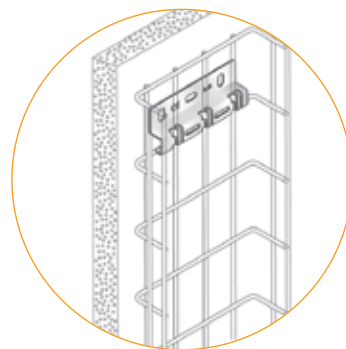
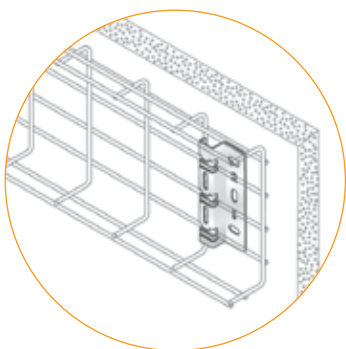
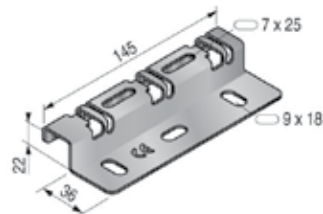

ZUF CLIP-ON CHANNELS - 3M

	M	Description	Code	Weight Kg/ml	Th. mm	daN
G	3	ZUF U 3M G	552148	0.985	1.75	100
	M	Description	Code	Weight Kg/ml	Th. mm	daN
ZM	3	ZUF U 3M ZM	553148	0.900	1.80	100
	M	Description	Code	Weight Kg/ml	Th. mm	daN
SS316	3	ZUF U 3M SS316	555148	1.037	1.50	100

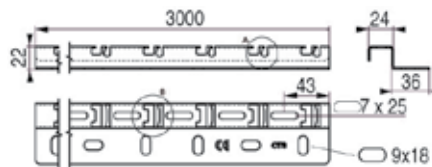
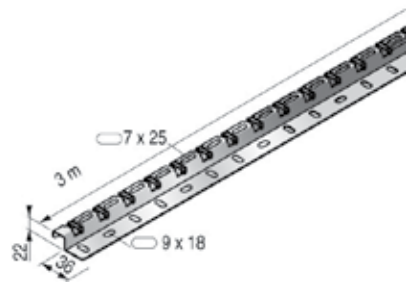

WALL AND FLOOR MOUNTING ACCESSORIES

SUL 50 BRACKETS

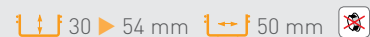

Central support for 50 mm wide mesh tray

Fast:

- Clip-on system
- Hands free
- No bolts
- Can be locked

Multifunctional:

- Suspension with  $\varnothing$  6-8 mm threaded rod or cable
- Can be fixed directly to ceiling, wall or floor thanks to 7x25 oblong hole
- Supports other equipment

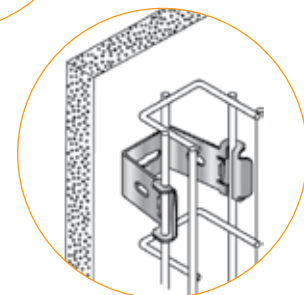
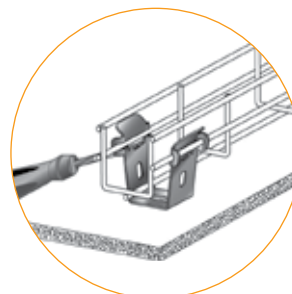
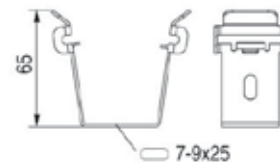
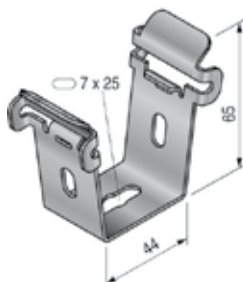

	P	Description	Code	Weight Kg/p	Th. mm	daN
G	10	SUL50 G	552118	0.073	1.75	40
	P	Description	Code	Weight Kg/p	Th. mm	daN
ZM	10	SUL50 ZM	553118	0.073	1.75	40
	P	Description	Code	Weight Kg/p	Th. mm	daN
SS304	10	SUL50 SS304	554118	0.070	1.50	40
	P	Description	Code	Weight Kg/p	Th. mm	daN
SS316	10	SUL50 SS316	555118	0.120	1.50	40

SV 50 BRACKETS



	P	Description	Code	Weight Kg/p	Th. mm	daN
G	20	SV50 G	552141	0.091	1.75	30
	P	Description	Code	Weight Kg/p	Th. mm	daN
ZM	20	SV50 ZM	553141	0.059	1.75	30
	P	Description	Code	Weight Kg/p	Th. mm	daN
SS304	20	SV50 SS304	554141	0.050	1.50	30
	P	Description	Code	Weight Kg/p	Th. mm	daN
SS316	20	SV50 SS316	555141	0.050	1.50	30

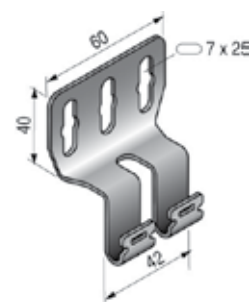

- 3 adjustment positions
- Hands free

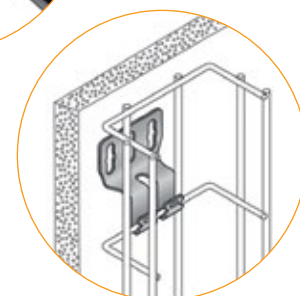
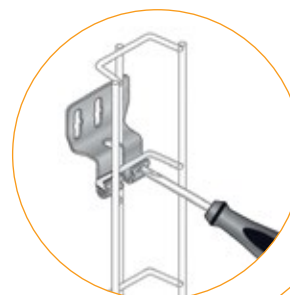



WALL AND FLOOR MOUNTING ACCESSORIES

PUF BRACKET

30 ▶ 54 mm 50 ▶ 100 mm

	P	Description	Code	Weight Kg/p	daN
G	50	PUF G	552036	0.026	20
	P	Description	Code	Weight Kg/p	daN
HDG	50	PUF HDG	553036	0.026	20
	P	Description	Code	Weight Kg/p	daN
SS304	50	PUF SS304	554036	0.025	20
	P	Description	Code	Weight Kg/p	daN
SS316	50	PUF SS316	555036	0.025	20

Direct wall fixing, for 50 mm wide cable trays

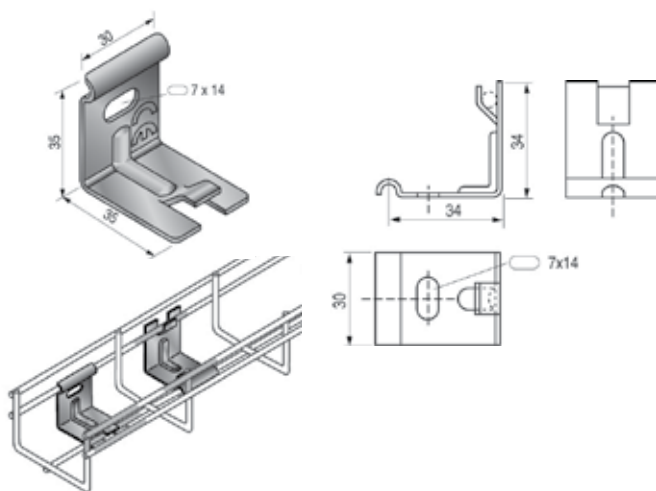

SH 100 BRACKET

30 ▶ 105 mm

	P	Description	Code	Weight Kg/p	daN
G	20	SH100 G	552142	0.250	150
	P	Description	Code	Weight Kg/p	daN
ZM	20	SH100 ZM	553142	0.250	150
	P	Description	Code	Weight Kg/p	daN
SS304	20	SH100 SS304	554142	0.208	150
	P	Description	Code	Weight Kg/p	daN
SS316	20	SH100 SS316	555142	0.210	150

- Mounting without bolt
- Mesh tray will be installed 46 mm above floor level

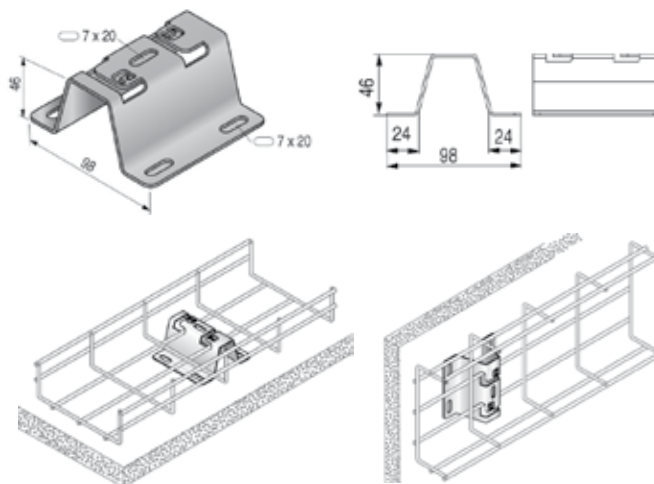

UFU BRACKET

30 ▶ 105 mm 100 ▶ 600 mm

	P	Description	Code	Weight Kg/p	daN
G	20	UFU G	552037	0.086	100
	P	Description	Code	Weight Kg/p	daN
ZM	20	UFU ZM	553037	0.065	100
	P	Description	Code	Weight Kg/p	daN
SS304	20	UFU SS304	554037	0.090	100
	P	Description	Code	Weight Kg/p	daN
SS316	20	UFU SS316	555037	0.090	100

**Multifunctional accessory, safe and robust:**

- Wall mounting (width 100 mm max.)
- Floor mounting
- Boxes or other equipment
- Lighting fixing
- Lock with screwdriver

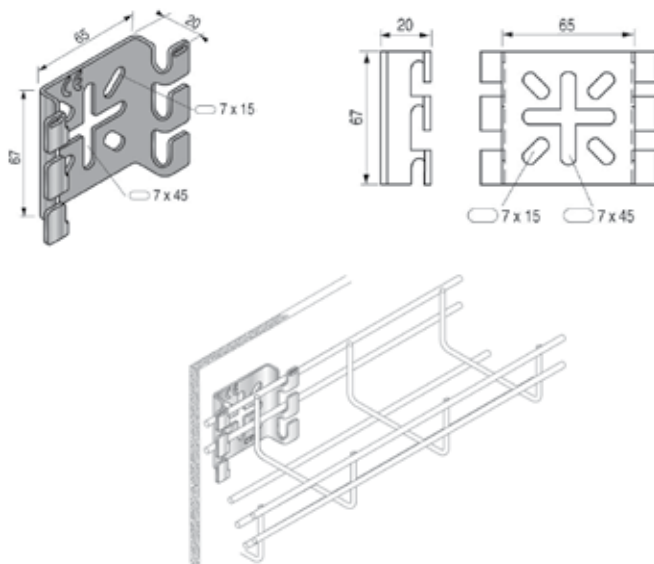

MESH TRAY TO BRACKET QUICK FIXING ACCESSORIES

GRSM.6 J-HOOK BOLT

	P	Description	Code	Weight Kg/100
EZ	50	GRSM.6 EZ	703103	1.160
	P	Description	Code	Weight Kg/100
HDG	50	GRSM.6 HDG	709819	1.160
	P	Description	Code	Weight Kg/100
SS304	50	GRSM.6 SS304	703612	1.150

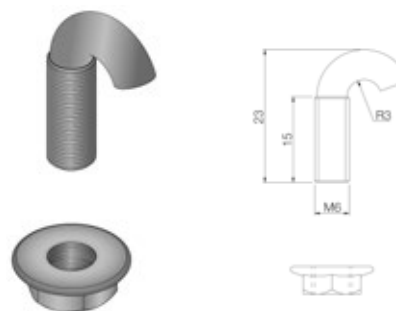

NEW !

QUARTER TURN FASTENER FOR STRUT 41 SUPPORTS

30 ▶ 54 mm 50 ▶ 200 mm

	P	Description	Code	Weight Kg/p
ZC	20	QDT ZAMAC	559170	0.034

Use for mounting mesh trays on 1,8 mm channels

- maximum width 200 mm for heights 30 and 54
- maximum width 150 mm for height 105
- Wire diameter 3,9 mm

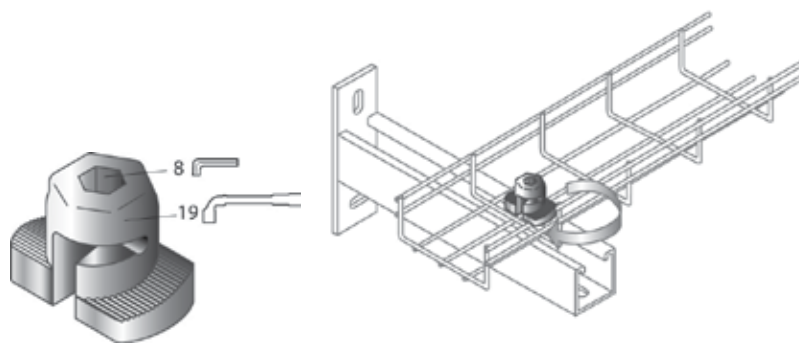

AGRAFIL

30/54/105 mm H30/H54 : 50 ▶ 200 mm / H105 : 100 mm

Quick universal and patented clip for perforated supports type:

- Light duty CU / CCU / BU
- Medium duty EDF / SU
- Heavy duty STRUT 41 (th. 1,8 mm)

Benefits:

- Locked in place
- Perfect alignment
- Time saving (no bolts)

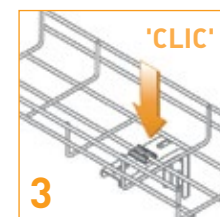
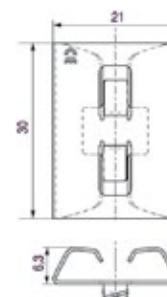
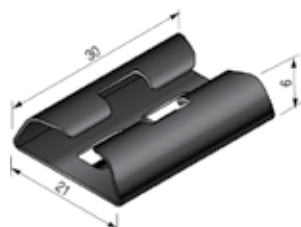

	P	Description	Code	Weight Kg/p
EZ	100	AGRAFIL EZ BLACK	552150	0.005

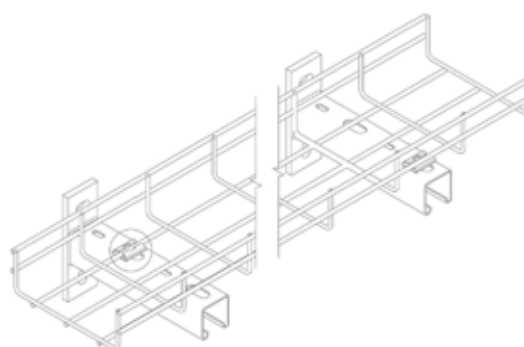
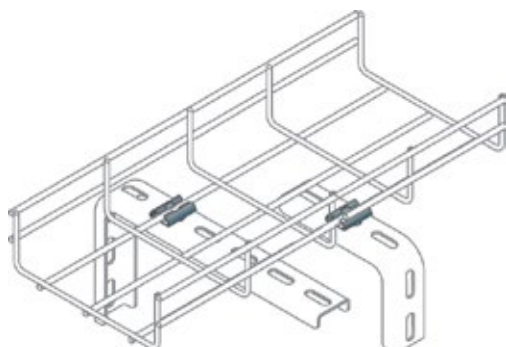

MESH TRAY TO BRACKET QUICK FIXING ACCESSORIES

PUF BRACKET



	P	Description	Code	Weight Kg/p	daN
G	50	PUF G	552036	0.026	20
	P	Description	Code	Weight Kg/p	daN
HdG	50	PUF HdG	553036	0.026	20
	P	Description	Code	Weight Kg/p	daN
SS304	50	PUF SS304	554036	0.025	20
	P	Description	Code	Weight Kg/p	daN
SS316	50	PUF SS316	555036	0.025	20

Recommended for :

- Bracket fixing for widths up to 100 mm
- Box or fixing other accessories

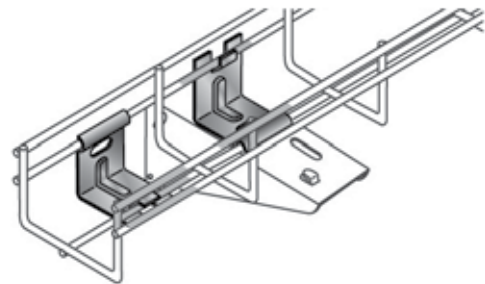
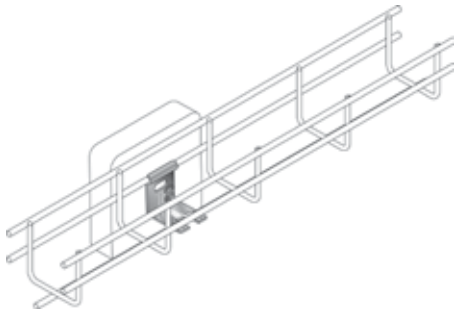
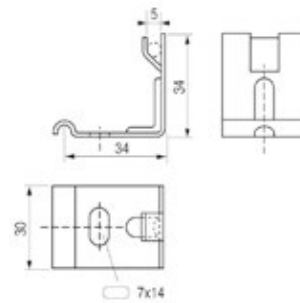
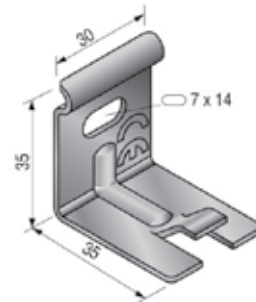

EARTHING SYSTEMS

F-CLIP



P	Description	Code	Weight Kg/p
G 40	FCLIP 16-35	651314	0.019

NEW !

Equipotential bonding of mesh trays  
Quick assembly, no tools

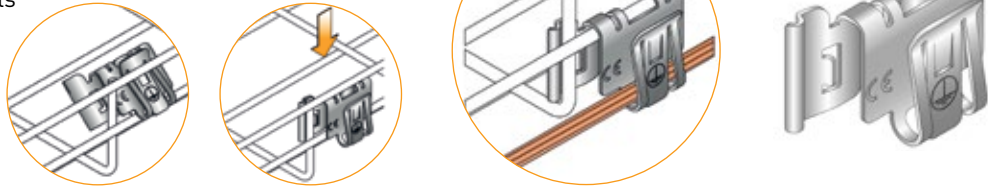

STU BRACKETS

U 30 ▶ 105 mm U 50 ▶ 600 mm

P	Description	Code	Weight Kg/p
G 25	STU G	552039	0.230
HDG 25	STU HDG	553039	0.254
SS316 25	STU SS316	555039	0.180

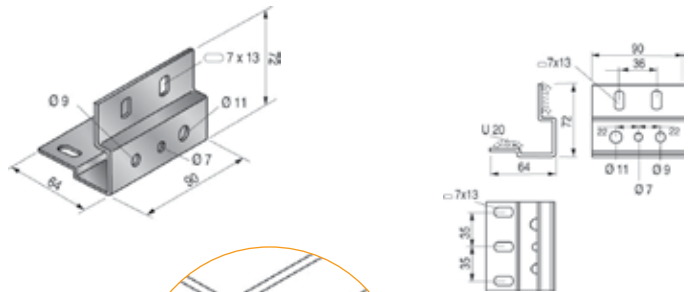

Fastening recommended with 3 U20 + 3 TRCC M6x20 bolts

MT 6/35 CLAMP

P	Description	Code	Weight Kg/p
BR 25	GMT 6/35	651311	0.040

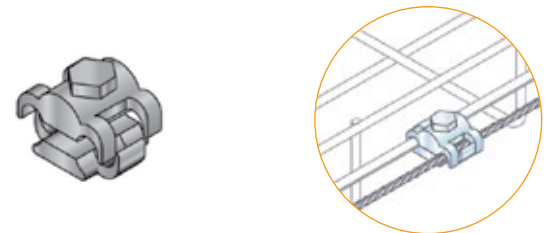

MT BOLTS

P	Description	Code	Weight Kg/p
BR 20	EARTH BOLT 6-25 mm <sup>2</sup>	651310	0.045
20	EARTH BOLT 6-35 mm <sup>2</sup>	651309	0.072
20	EARTH BOLT 6-50 mm <sup>2</sup>	651303	0.072
20	EARTH BOLT 6-95 mm <sup>2</sup>	651300	0.080

Delivered with 2 Alumium/Copper washers  
+ 1 TRL M6x12 screw EZ

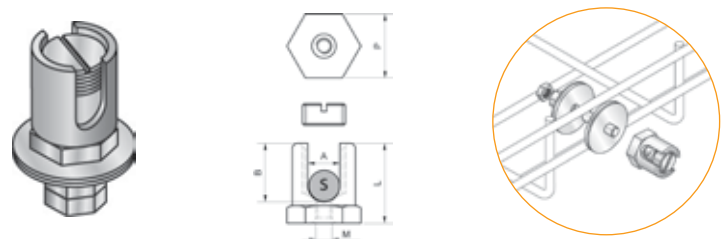

OTHER ACCESSORIES

UFU BRACKETS



	P	Description	Code	Weight Kg/p	daN
<b>G</b>	20	UFU G	552037	0.086	100
	P	Description	Code	Weight Kg/p	daN
<b>ZM</b>	20	UFU ZM	553037	0.065	100
	P	Description	Code	Weight Kg/p	daN
<b>SS304</b>	20	UFU SS304	554037	0.090	100
	P	Description	Code	Weight Kg/p	daN
<b>SS316</b>	20	UFU SS316	555037	0.090	100

**Multifunctional accessory, safe and robust:**

- Boxes or other equipment
- Lighting fixing
- Lock with a screwdriver

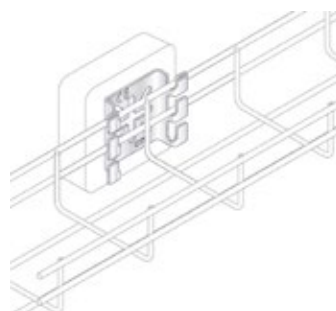
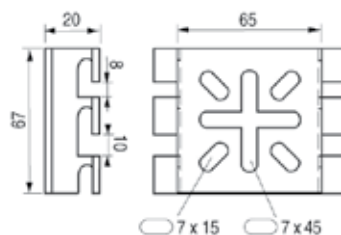
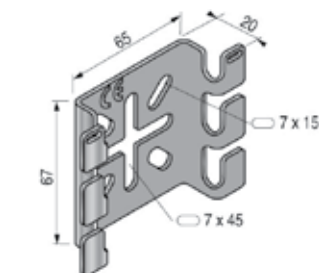
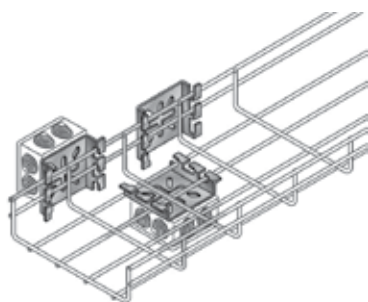

SBP BRACKET

30 ▶ 105 mm 50 ▶ 600 mm



	P	Description	Code	Weight Kg/p	Th. mm
<b>G</b>	10	SBP G	552145	0.400	1.00
	P	Description	Code	Weight Kg/p	Th. mm
<b>ZM</b>	10	SBP ZM	553145	0.400	1.00

- Easy to install without bolts and from the outside after laying cables
- Compatible with all types of boxes
- Can be locked with one **KU20 bolt** or a screwdriver

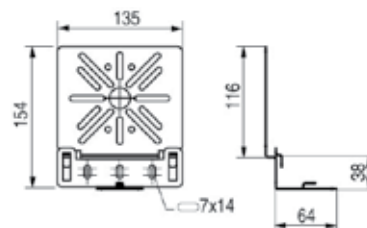
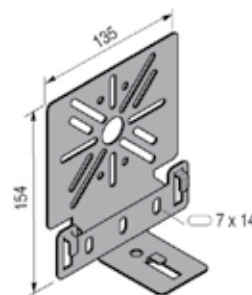
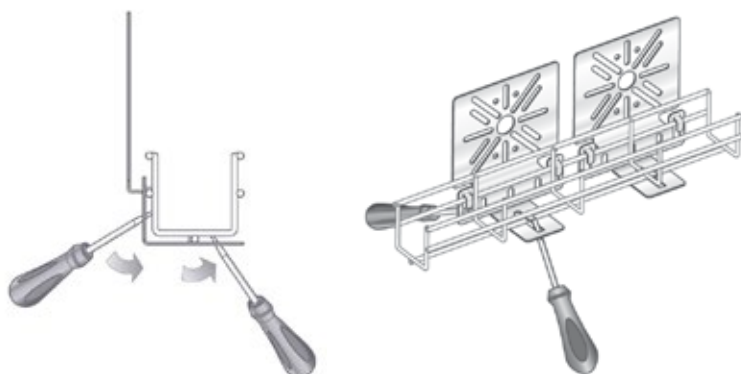

OTHER ACCESSORIES

SC CABLE DROP OUT

30 ▶ 105 mm 100 ▶ 600 mm

	P	Description	Code	Weight Kg/p
G	10	SC UF G	552144	0.300
	P	Description	Code	Weight Kg/p
ZM	10	SC UF ZM	553144	0.176
	P	Description	Code	Weight Kg/p
SS304	10	SC UF SS304	554144	0.220
	P	Description	Code	Weight Kg/p
SS316	10	SC UF SS316	555144	0.140

- **Assembly without bolts**
- Locking with a screwdriver
- Perforation for pipe clamp
- Compatible with any type of mesh tray of width from 100 to 600 mm

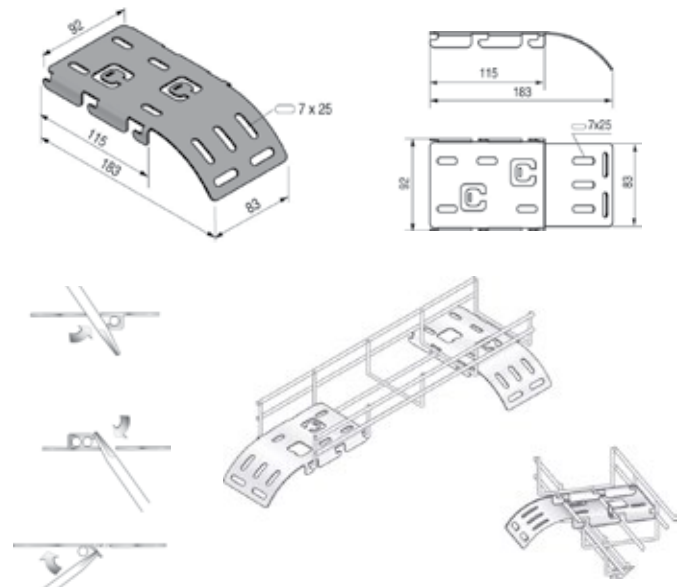

SLU 100 BRACKETS

30 ▶ 105 mm 100 ▶ 600 mm

	P	Description	Code	Weight Kg/p	daN
G	10	SLU 100 G	552146	0.211	150
	P	Description	Code	Weight Kg/p	daN
ZM	10	SLU 100 ZM	553146	0.220	150
	P	Description	Code	Weight Kg/p	daN
SS304	10	SLU 100 SS304	554146	0.220	150

Alternative: **SUL 50** for 50 mm wide mesh tray

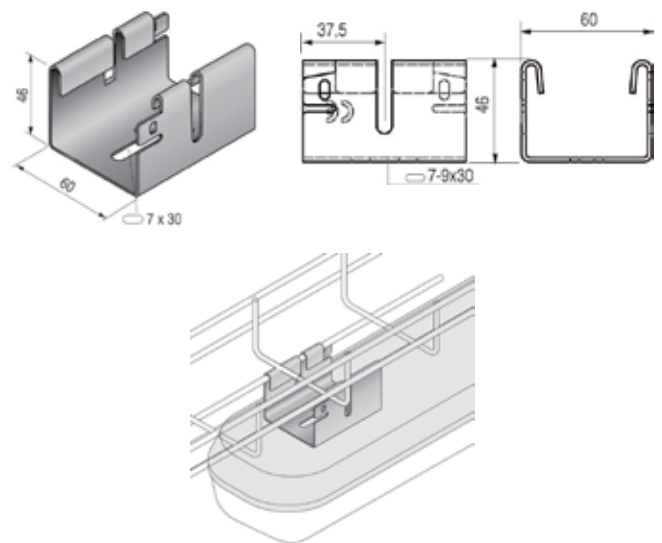

BOLT CUTTER

	P	Description	Code	Weight Kg/p
10		BOLT CUTTER	552080	2.588

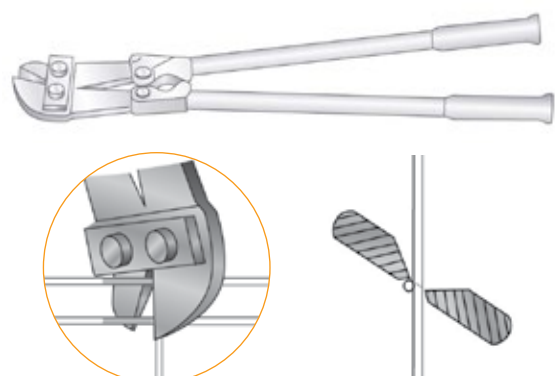





A series of horizontal lines for writing notes, starting from the top right of the page and extending downwards.