

Overhead Hanger- and Wall Bracket

medium duty

KTAM 150

EAN Code: 4013339078530
 Smallest packaging unit:20 pcs.

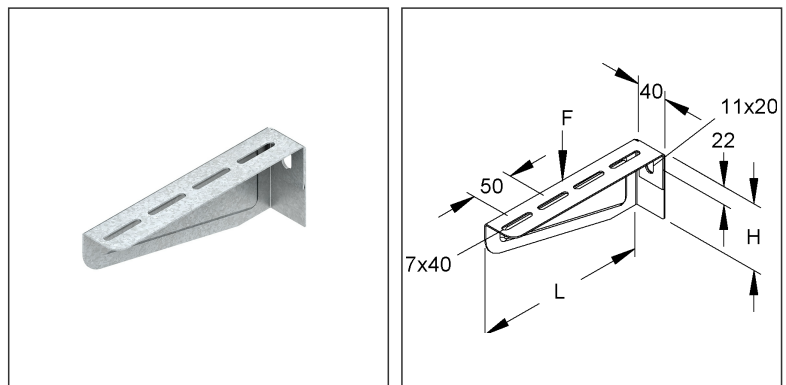

Article Description

Overhead hanger- and wall bracket, medium duty, 60x160 mm, 1,2 kN, steel, pre-galvanised according to DIN EN 10346, incl. accessories

Incl. accessories

2 FLM 6X12

Additional Price Information

Article group	N13
quantity unit	pcs.

Weight

Weight per quantity unit	222 g / pcs.
Weight in kg per 100	22 kg / 100pcs.

Technical Datasheet

Supporting structure

KTAM 150

Physical Article Dimensions

Height	60.00 mm
Width	40.00 mm
Depth/length	161.50 mm

Packing Dimension

20 pieces = 1 carton		✓ VP1-smallest packaging unit (PU)		✓ VP1-preferred PU	
Lenght	210 mm	Width	150.00 mm	Height	100.00 mm
Gross weight	4,61 kg	Volume	0,003 m ³		
Min. quantity	20.00 pcs.	Max. Quantity	20.00 pcs.		
1000 pieces = 1					
Lenght	750 mm	Width	750 mm	Height	730 mm
Gross weight	271 kg	Volume	0,411 m ³		
Min. Quantity	1.000.00 pcs.	Max. Quantity	1.000.00 pcs.		

Tender Text

Overhead hanger and wall bracket, medium duty, for wall and overhead hanger mounting, including proportional fastening accessories. The carrying capacity data are only valid if they are sufficiently anchored to the supporting ground or if they are mounted on overhead hangers according to regulations.

VDE certified!

Dimensions (approx. dimensions)

Support height H : 60 mm

Support length L : 160 mm

Load capacity F at L/2 : 1.2 kN tested in the system

Material bracket : Steel, pre-galvanised acc. to DIN EN 10346

NIEDAX Model No. : KTAM 150

EP Material_____ EP Wage_____

Unit price/piece

Safety & Environment

REACH Date	17.01.2023
REACH Info	Conformable
RoHS Info	Conformable

Origin & International Trade

Country of origin	DE
Customs tariff number	73089059