

**Overhead Hanger- and Wall Bracket**

medium duty

**KTAM 100**

EAN Code: 4013339186303  
 Smallest packaging unit:20 pcs.

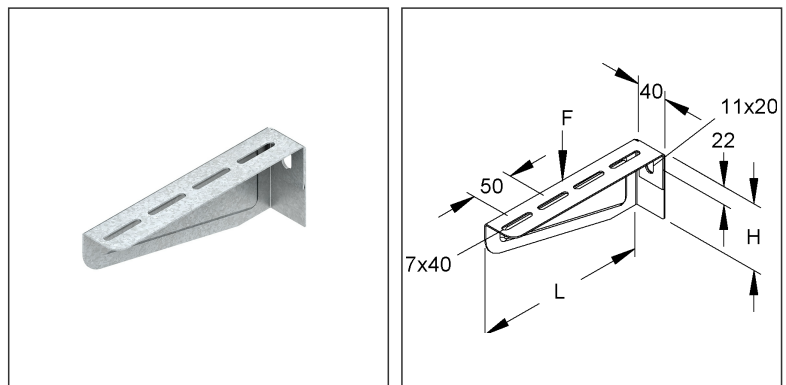

**Article Description**

Overhead hanger- and wall bracket, medium duty, 60x110 mm, 1,2 kN, steel, pre-galvanised according to DIN EN 10346, incl. accessories

**Incl. accessories**

2 FLM 6X12

**Additional Price Information**

Article group	N13
quantity unit	pcs.

**Weight**

Weight per quantity unit	166 g / pcs.
Weight in kg per 100	17 kg / 100pcs.

# Technical Datasheet

## Supporting structure

### KTAM 100

#### Physical Article Dimensions

Height	60.00 mm
Width	40.00 mm
Depth/length	111.50 mm

#### Packing Dimension

<b>20 pieces = 1 carton</b>		✓ VP1-smallest packaging unit ( PU)		✓ VP1-preferred PU	
Lenght	205 mm	Width	120.00 mm	Height	80.00 mm
Gross weight	3,46 kg	Volume	0,002 m <sup>3</sup>		
Min. quantity	20.00 pcs.	Max. Quantity	20.00 pcs.		
<b>1500 pieces = 1</b>					
Lenght	750 mm	Width	750 mm	Height	730 mm
Gross weight	299 kg	Volume	0,411 m <sup>3</sup>		
Min. Quantity	1.500.00 pcs.	Max. Quantity	1.500.00 pcs.		

#### Tender Text

Overhead hager and wall bracket, medium duty, for wall and overhead hanger mounting, including proportional fastening accessories. The carrying capacity data are only valid if they are sufficiently anchored to the supporting ground or if they are mounted on overhead hangers according to regulations.  
VDE certified!  
Dimensions (approx. dimensions)  
Support height H : 60 mm  
Support length L : 110 mm  
Load capacity F at L/2 : 1.2 kN tested in the system  
Material bracket : Steel, pre-galvanised acc. to DIN EN 10346  
NIEDAX Model No. : KTAM 100  
EP Material\_\_\_\_\_ EP Wage\_\_\_\_\_  
Unit price/piece

#### Safety & Environment

REACH Date	17.01.2023
REACH Info	Conformable
RoHS Info	Conformable

#### Origin & International Trade

Country of origin	DE
Federal State of Origin	RP
Customs tariff number	73089059