

Grid and System Protection Relay

URNA0345-B

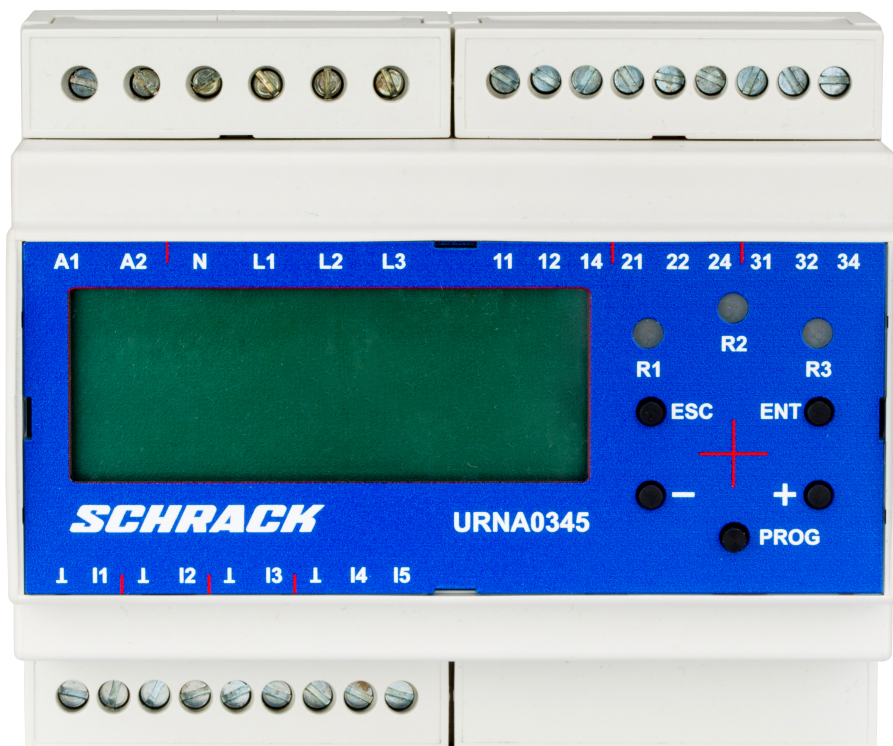

USER MANUAL

for SW: 02.14.02h

Subject to modifications and errors



**CLIMATE NEUTRAL
PRODUCT**
certified by Fokus Zukunft

Table of content

1	Safety	6
1.1	Intended use	6
1.2	Safety advice	6
1.3	Qualified electrician	7
2	Installation and connection	7
2.1	Dimensions and operating elements.....	7
2.2	Back-up fuse of the supply voltage	7
2.3	Terminal allocation.....	8
2.4	Installation on top-hat rail according to EN 60715.....	8
2.5	Circuit diagram 1 (general, without activities for FRT)	9
2.6	Circuit diagram 2 (general, with activities for FRT)	10
2.7	Circuit diagram 3 (CEI 0-21).....	11
2.8	Circuit diagram 4 (C10/11).....	12
3	Function.....	13
3.1	Features	13
3.2	Commissioning	13
3.3	Functional description	13
3.4	Protection functions / comparators.....	15
3.4.1	Voltage monitoring.....	15
3.4.2	Frequency monitoring	16
3.4.3	Phase shift monitoring.....	16
3.5	Loss Of Mains (Microgrid) detection	17
3.5.1	Loss Of Mains (Microgrid) detection via voltage measurement	17
3.5.2	Loss Of Mains (Microgrid) detection via RoCoF	17
3.5.3	Loss Of Mains (Microgrid) detection via vector shift.....	17
3.6	Test function	17
3.7	Digital inputs	17
3.8	Output relays R1, R2 and R3	18
3.9	Error	19
3.9.1	Measurement error.....	19
3.9.2	System error.....	19
3.9.3	Error memory (LOG).....	19
3.10	Novelties concerning country-specific parameter sets.....	20
3.10.1	VDE-AR-N 4105:2018	20
3.10.2	C10/11:2021	21
3.10.3	EN50549-1/2:2019 (default Netherlands).....	22
3.10.4	OPEN_SETUP	22
4	Operation and commissioning.....	23
	Initial commissioning	23

4.1	Menu navigation.....	23
4.1.1	Level 0.....	23
4.1.2	Level 1.....	23
4.1.3	Level 2.....	24
4.1.4	Level 3.....	24
4.1.5	Level 4.....	24
4.1.6	Level 5.....	25
4.2	Operating menu structure	26
4.3	Lead seal.....	27
4.4	Use cases.....	27
4.4.1	Use of voltage transformers in medium power mains (OVE TOR R25, OOE TOR R25).....	27
4.4.2	FRT (Fault Ride Through) capability of generators:	28
4.4.3	Self retention for remote shutdown with manual reset.....	30
4.4.4	Connection of a load management device for power reduction 0%	30
4.5	Supply circuit.....	31
4.6	Measuring circuit.....	31
4.7	Measuring ranges.....	32
4.8	Digital inputs.....	32
4.9	Output circuit.....	32
4.10	Accuracy.....	32
4.11	Insulation data.....	33
4.12	Environmental conditions	33
4.13	Electrical connection	33
4.14	Sealing wire	33
4.15	Protection class.....	33
5	Settings of the implemented parameter sets.....	34
5.1.1	Connection Modes	34
5.1.2	Units.....	34
5.1.3	Functional safety	34
5.1.4	Operational mode	34
5.1.5	Thresholds.....	34
5.1.6	Times.....	35
5.1.7	Auxiliary contact	35
5.1.8	Ranges	35
6	Safety concept	36
7	Glossary.....	38
8	Standards and Norms available	39
9	Overview of the implemented parameter sets	43
9.1	OVE TOR R25 NS SYNC (Typ A/B low voltage for sync. generators).....	43
9.2	OVE TOR R25 NS ASYNC (Typ A/B low voltage for async. generators)	43
9.3	OVE TOR R25 MS SYNC (Typ A/B medium voltage for sync. generators).....	43

9.4	OVE TOR R25 MS ASYNC (Typ A/B medium voltage for async. generators)	44
9.5	OOE TOR R25 NS SYNC (Typ A/B low voltage for sync. generators).....	44
9.6	OOE TOR R25 NS ASYNC (Typ A/B low voltage for async. generators)	44
9.7	OOE TOR R25 MS SYNC (Typ A/B medium voltage for sync. generators).....	45
9.8	OOE TOR R25 MS ASYNC (Typ A/B medium voltage for async. generators)	45
9.9	W TOR R25 NS SYNC (Typ A/B low voltage for sync. generators)	45
9.10	W TOR R25 NS ASYNC (Typ A/B low voltage for async. generators).....	46
9.11	W TOR R25 MS SYNC (Typ A/B medium voltage for sync. generators)	46
9.12	W TOR R25 MS ASYNC (Typ A/B medium voltage for async. generators).....	46
9.13	TIROL TOR NS SYNC (Typ A/B low voltage for sync. generators)	47
9.14	TIROL TOR NS ASYNC (Typ A/B low voltage for async. generators).....	47
9.15	TIROL TOR MS SYNC (Typ A/B medium voltage for sync. generators)	47
9.16	TIROL TOR MS ASYNC (Typ A/B medium voltage for async. generators).....	47
9.17	VDE-AR-N 4105:2018-11 (Pn ≤ 50 kW)	48
9.18	VDE-AR-N 4105:2018-11 (Pn > 50 kW).....	48
9.19	VDE-AR-N 4105:2018-11 (inverter).....	48
9.20	VDE-AR-N 4110:2018-11 (tested according to TR3, evaluation report TR8).....	49
9.21	CEI 0-21:2019	49
9.22	G99/1/3 LV:2018 (low voltage)	49
9.23	G99/1/3 HV:2018 (medium/high voltage).....	50
9.24	G98/1/2:2018 (low voltage).....	50
9.25	C10-11 2019 LV-IP (Interface Protection / low voltage).....	50
9.26	C10-11 2019 LV-ASS (Automatic Separation System / low voltage).....	51
9.27	C10-11:2019 HV-IP (Interface Protection / high voltage).....	51
9.28	C10-11:2019 HV-ASS (Automatic Separation System /high voltage)	51
9.29	NA/EEA- CH 2014 Type A up to 1MW (Low Voltage)	52
9.30	NA/EEA-NE7 - CH 2020 Type A 800W to 250kW (Low Voltage).....	52
9.31	NA/EEA-NE7 - CH 2020 Type B 250kW to 36MW (Low Voltage)	52
9.32	EN 50549-1:2019 LV (Netherlands).....	53
9.33	EN 50549-2:2019 HV (Netherlands).....	53
9.34	EN 50438:2013 (DK).....	54
9.35	VDE 0126-1-1:2013 (ERDF-NOI-RES_13E Frankreich).....	54
9.36	AB AS 4777.2:2020.....	54
9.37	C AS 4777.2:2020	55
9.38	NZS 4777.2:2020.....	55
9.39	NRS 097-2-1: 2017	56
9.40	OPEN SETUP	56
9.41	EN 50438:2013	57
9.42	E 8001/8101 (previous standard of OVE TOR R25).....	57
9.43	VDE 0124-100:2013 (previous standard of VDE-AR-N 4105:2018-11)	57
9.44	TR3 Rev23:2013 (previous standard of VDE-AR-N 4110:2018-11)	57

9.45	AS/NZS 4777.2:2015 (low voltage).....	58
9.46	G59/3/3:2015 LV (low voltage – the previous standard of G99/1/3 LV:2018).....	58
9.47	G59/3/3:2015 MV (high voltage – the previous standard of G99/1/3 HV:2018).....	58
9.48	G83/2:2012 (low voltage – previous standard of G98/1/2:2018)	59
9.49	C10-11:2012 LV (low voltage – previous standard of C10-11:2019)	59
9.50	C10-11:2012 MV (high voltage – previous standard of C10-11:2019).....	59
9.51	C10-11:2019 LV-IP (Interface Protection / low voltage - previous standard of C10-11:2021).....	60
9.52	C10-11:2019 HV-IP (Interface Protection / high voltage - previous standard of C10-11:2021)	60
10	APPENDIX	61

1 Safety

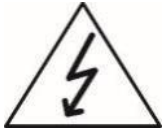

**Caution! Never work when voltage is applied.
This poses a life-threatening risk! Never use the device if there is obvious
damage! Use only by trained specialist personnel!**



**Professional product!
This product requires special expertise for the installation!**



**This device is subject to the Waste Electrical Equipment Regulation (WEEE)
and may not be disposed of with normal domestic waste. The device is made
of materials that can be recycled by specialized recycling companies. The
device must be disposed of according to the national electronic scrap
regulations.**

1.1 Intended use

The URNA0345-B serves as grid and system protection for supplying cogeneration units, wind power stations, hydroelectric power plants, and photovoltaic systems.

In the event of a power failure or a fault in the grid of the energy supply company, private small power plants must immediately be isolated from the public grid to prevent accidental infeed. For one, maintenance personnel could be endangered without immediate grid separation, and secondly, consumers could be exposed to impermissible voltages and frequencies.

In case the grid operator requires threshold values that deviate from the standards, it is possible in part to set some of the threshold values outside of the standard defined range.

Outside of this range the device is no longer in compliance with standards and the corresponding certificates lose their validity. This status is shown on the display by the identifier "ncnf." Settings outside of this range are therefore within the operator's scope of responsibility and/or the acceptance authority of the system.

1.2 Safety advice

This device was built and tested under-recognized technical safety regulations. However, incorrect use can still result in danger for both persons and machines.

Only use this device as intended, in a technical safe condition, and compliance with the applicable rules and regulations for accident prevention valid at the usage location.

- Fix all faults that could impair the safety immediately.
- Do not make any unauthorized changes and only use spare parts and additional devices that are sold or expressly recommended by the manufacturer of the device.
- The device may no longer be used in case of obvious damage.
- Country-specific standards and guidelines are to be observed.
- The URNA0345-B can be protected against authorized changes after commissioning via password protection or sealing. One of the protection mechanisms named above must be applied if this is required in the respective country-specific standard or guidelines.

1.3 Qualified electrician

A qualified electrician can independently recognize and prevent dangers from electricity. Requirements for this are:

- Knowledge of electrical engineering
- Experience in electrical work
- Knowledge and work experience with the corresponding system or similar systems (system type)
- Knowledge of the hazards and countermeasures
- The ability to recognize whether safety is provided during the performance of work

Qualified electricians are specially trained and know the relevant standards and regulations for the work environment in which they are active. The regulations of the corresponding country apply.

2 Installation and connection

2.1 Dimensions and operating elements

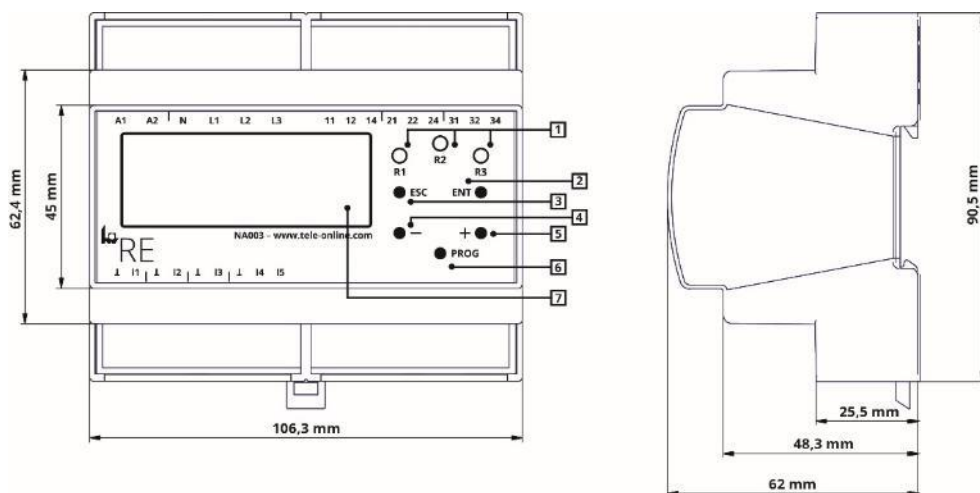

Legend	Labeling	Type	Function
1	R1, R2, R3	LED (yellow)	Output relay status display
2	ENT	Button	ENTER, input confirmation, next level
3	ESC	Button	ESCAPE, input rejection, back a level, Test
4	-	Button	Parameter setting, display change
5	+	Button	Parameter setting, display change
6	PROG	Button (can be sealed)	PROGRAM, programming
7		LCD-display 4x20 characters	Display

2.2 Back-up fuse of the supply voltage

The supply and measuring voltages of all system components are to be secured with back-up fuses. The back-up fuses are to be dimensioned according to the conductor cross-section used.

We recommend securing the output relay against the danger of short-circuiting with a 5A fast-acting fuse!

2.3 Terminal allocation

A1, A2	Supply circuit	DC: 24V AC: 110 - 230V A1: L (+) A2: N (-)
L1, L2, L3, N	Measuring circuit	U _N : 3x400V AC
11, 12, 14	Output relay channel A (changeover contact) Status display through yellow LED R1	Contact output (isolated) 11: Root 12: Normally closed contact (n.c.) 14: Normally open contact (n.o.)
21, 22, 24	Output relay channel B (changeover contact) Status display through yellow LED R2	Contact output (isolated) 21: Root 22: Normally closed contact (n.c.) 24: Normally open contact (n.o.)
31, 32, 34	Output relay channel D (changeover contact) Status display through yellow LED R3	Contact output (isolated) 31: Root 32: Normally closed contact (n.c.) 34: Normally open contact (n.o.)
11, ⊥	Digital input 1 (feedback contact of contactor A)	Contact input (24V/5mA) Input active: when I1 and ⊥ connected (configurable)
12, ⊥	Digital input 2 (feedback contact of contactor B)	Contact input (24V/5mA) Input active: when I2 and ⊥ connected (configurable) Not applicable for all country-specific standards in which no functional safety is required!
13, ⊥	Digital input 3 (remote shutdown)	Contact input (24V/5mA) Input active: I3 and ⊥ connected (configurable)
14, 15, ⊥	Digital input 4 and 5 (Switchover to narrower frequency window)	For CEI 0-21 and C10/11 Contact input (24V/5mA) Input active: when I4 resp. I5 and ⊥ connected

2.4 Installation on top-hat rail according to EN 60715

Latch the mounting clip on the reverse of the device to the top-hat rail so that a safe and secure fit is ensured.

2.5 Circuit diagram 1 (general, without activities for FRT)

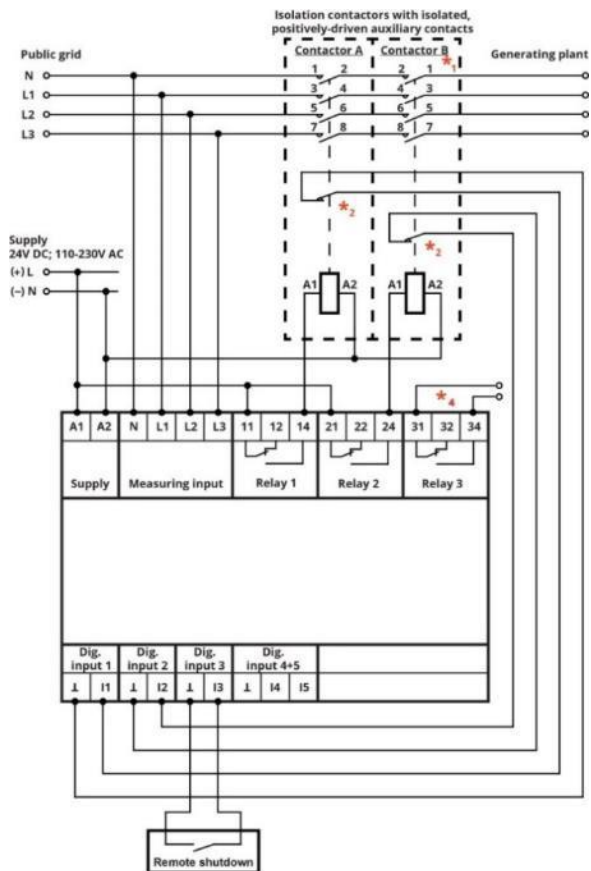

To be used for:

Actual standards

OVE TOR R25 NS/MS A/SYNC,
 OOE TOR R25 NS/MS A/SYNC
 W TOR R25 NS/MS A/SYNC
 TIROL TOR NS/MS A/SYNC
 VDE-AR-N 4105:2018-11 (Pn ≤ 50 kW) *₁, *₄, *₅
 VDE-AR-N 4105:2018-11 (Pn > 50 kW) *₁, *₄, *₅
 VDE-AR-N 4105:2018-11 (Inverter) *₄, *₅
 VDE-AR-N 4110:2018-11 *₁
 G99-1-3 LV:2018 *₁
 G99-1-3 HV:2018 *₁
 G98-1-2:2018 *₁
 C10-11:2019 LV-ASS *₁, *₄
 C10-11:2019 HV-ASS *₁, *₄
 EN50549-1:2019 LV *₃
 EN50549-2:2019 HV *₃
 EN50438:2013 DK *₃
 VDE 0126-1-1:2013 *₃
 AS/NZS 4777.2:2020 *₃
 NRS 097-2-1:2017 *₃
 OPEN SETUP *₃

Recertified standards

EN50438:2013 *₁
 OVE E 8001-4-712 / E 8101-4-712 *₁
 VDE 0124-100:2013 *₁
 TR3 Rev23:2013 *₁
 AS/NZS 4777.2:2015 *₁
 G59/3/3:2015 LV *₁
 G59/3/3:2015 MV *₁
 G83/2:2012 *₁
 C10-11:2012 LV *₁
 C10-11:2012 MV *₁
 C10-11:2019 LV-IP *₁, *₄
 C10-11:2019 HV-IP *₁, *₄

- *₁ ... Contactor B not applicable for all country-specific standards in which no functional safety is required!
- *₂ ... Auxiliary contact as normally opened, normally closed, or can be configured "not monitored".
- *₃ ... 1- or 2-channel connection possible and can be configured.
- *₄ ... Evaluation, contact error for autogeneration plants only for VDE-AR-N 4105:2018-11 and C10-11:2019
- *₅ ... VDE-AR-N 4105:2018-11 FRT (fault ride through) behavior with buffered isolation contactors.

2.6 Circuit diagram 2 (general, with activities for FRT)

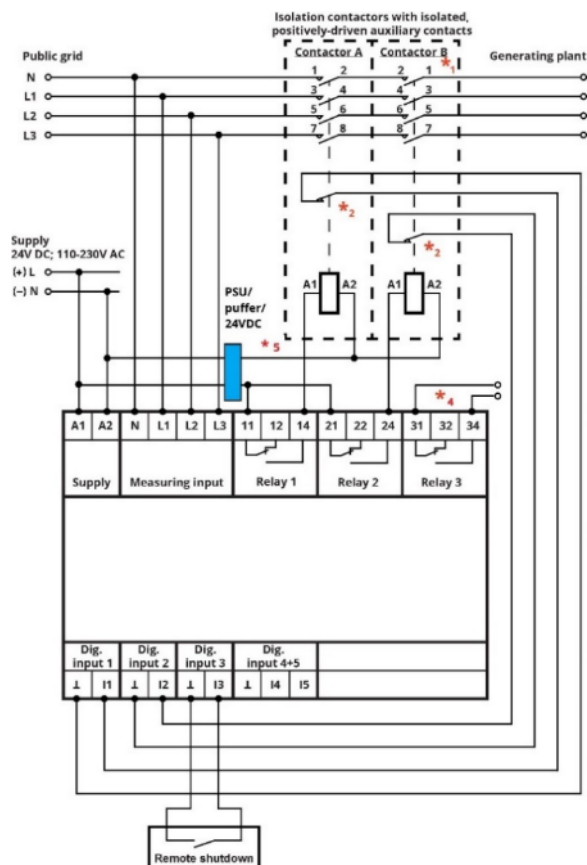

To be used for:

Standards as described in chapter 2.5

*5 FRT (fault ride through) behavior with buffered isolation contactors

Power supply / buffer. Isolation contactors and coupling relays, if present, must be buffered for 3s/0.3s in the event of undervoltage (FRT).

Power generation devices into low-voltage networks must help to stabilize the network. Therefore, the isolating contactor must not drop out at a voltage just above $U \ll (0.45 U_n)$ or 0.3s in the event of a voltage interruption due to undervoltage. Only the URNA0345-B switches the contactor off after 3s ($U <$) or 0.3s ($U \ll$). A power supply / buffer is required.

When using 2 isolating contactors, both must be supplied for 3s. The URNA0345-B has an internal broadband power supply and therefore does not need a buffered control voltage.

*1 ... Contactor B not applicable for all country-specific standards in which no functional safety is required!

*2 ... Auxiliary contact as normally opened, normally closed, or can be configured "not monitored".

*3 ... 1- or 2-channel connection possible and can be configured.

*4 ... Evaluation, contact error for autogeneration plants only for VDE-AR-N 4105:2018-11 and C10-11:2019

*5 ... VDE-AR-N 4105:2018-11 FRT (fault ride through) behavior with buffered isolation contactors.

2.7 Circuit diagram 3 (CEI 0-21)

To be used for:

CEI 0-21:2019

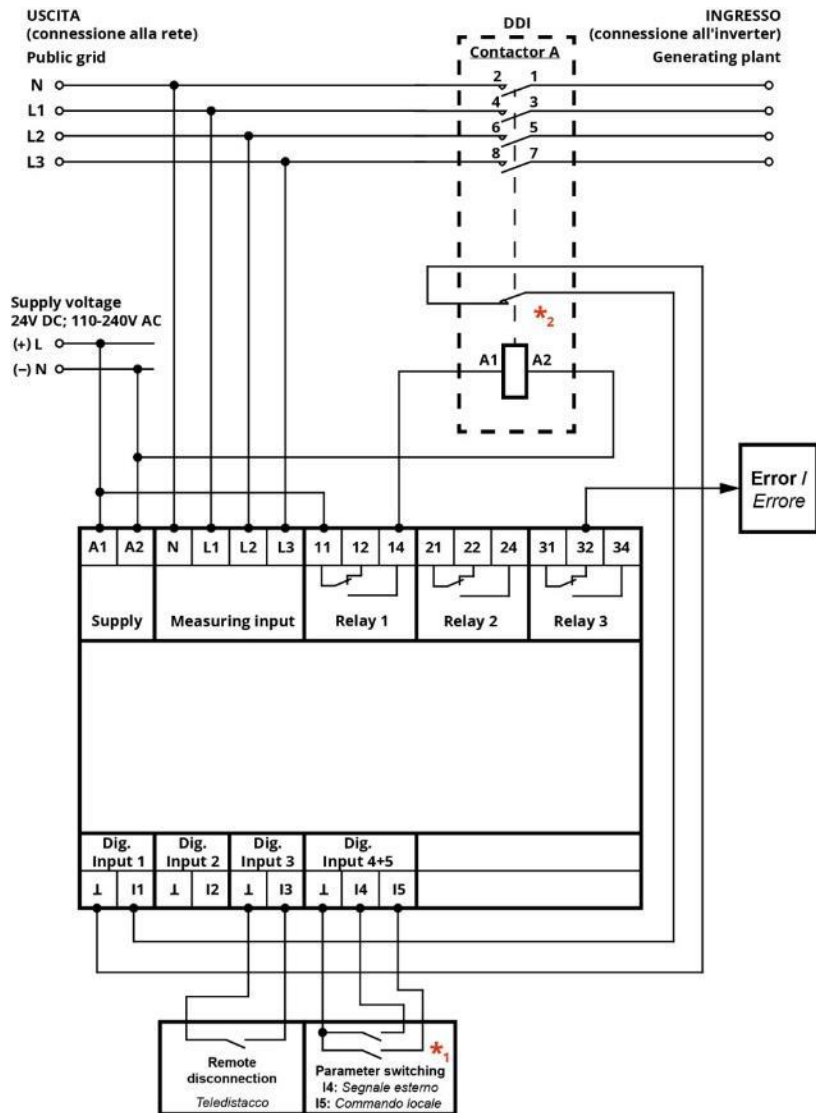

*₁ Parameter switching:

definitive mode (Operational mode 0):

I4 inactive / contact open:

I4 active / contact closed:

transitory mode (Operational mode 1):

I5 active / contact closed:

I5 inactive / contact open:

overfrequency 1, underfrequency 1

overfrequency 2, underfrequency 2

overfrequency 2, underfrequency 2

overfrequency 3, underfrequency 3

*₂ Auxiliary contact as normally opened, normally closed, or can be configured "not monitored"

2.8 Circuit diagram 4 (C10/11)

To be used for:

C10/11:2021 LV

C10/11:2021 HV

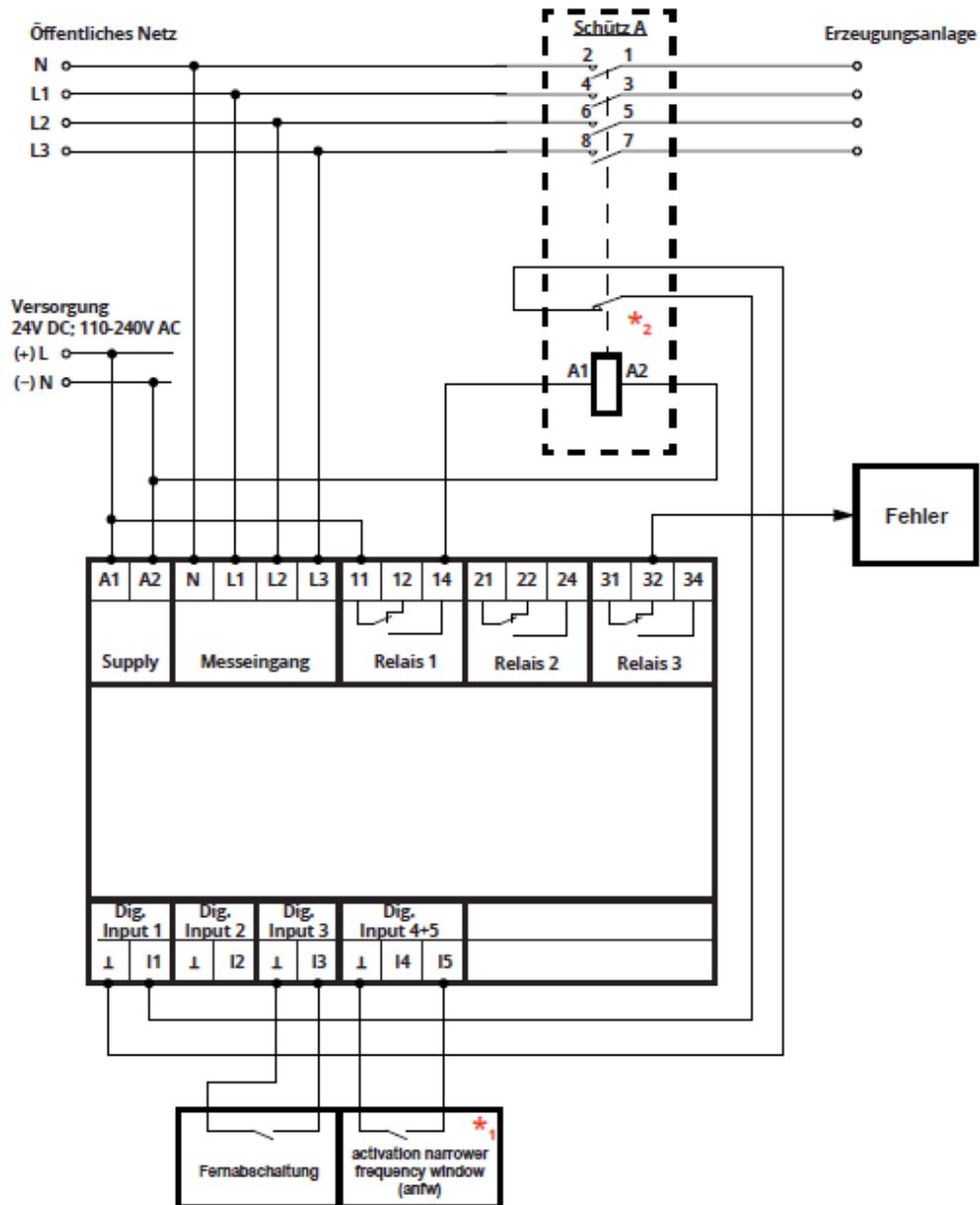

*₁ Parameter switching:

I5 inactive / contact opened:

Overfrequency 1, Underfrequency 1

I5 active / contact closed:

Overfrequency 2, Underfrequency 2 (narrower frequency window)
(based on local voltage criteria / local setting)

*₂ Auxiliary contact configurable as normally closed, normally open or "not monitored"

3 Function

3.1 Features

- Simple implementation through pre-defined setups for country-specific standards and guidelines with parameters that can be set within a wide range.
- Wide nominal voltage and nominal frequency range, configurable nominal voltage
- Protection functions: U<<, U<, U>, U>>, U_{10min}, f<, f>, f<<, f>>
- Additional "Open setup" for free, practically unlimited parametrization in the field
- Single-fault tolerance
- Cyclical self-test
- Monitoring of the connected section switch
- Remote shutdown
- Loss of mains detection (RoCoF, PShift, phase voltage)
- Test function with the determination of the turn-off time of the connected isolated contactors
- Monitoring of 1- and 3- phase grids for low and medium voltage grids
- Error memory with a timestamp (50 entries)
- Password protection and ability to seal
- Random turn-off thresholds and turn-on times for non-controllable energy producers (e.g. CHP)
- Detection of the symmetrical component "Zero Sequence" in the 3-phase network (U_{zero})
- Switching to different frequency bands (narrower frequency window)
- FRT (fault ride through) capability
- Configuration service and single test protocols

3.2 Commissioning

After applying the supply voltage to A1 and A2, the start display appears for 5 seconds. The device is delivered without a preselected parameter set. During initial commissioning, the device enters parameter set selection (level 5 - menu item 5.001). Here, the corresponding country-specific parameter set/standard must be selected using +/- and confirmed with ENTER. For more information, see 4.1 Menu navigation.

3.3 Functional description

Depending on the country-specific configuration selected, the device can handle several monitoring functions (protection functions) at the same time.

Unless otherwise stated, the nominal voltage is 230V/400V and the nominal frequency is 50Hz (check menu item 1.010).

1.010	df1t	60
U1	230.0V	f 50.00Hz
U2	230.0V	
U3	230.0V	

After exceeding or falling below a threshold value, R1 and R2 switch off after a response-delay that is defined especially for each threshold value. During the self-test or when the remote shutdown is activated, R1 and R2 switch off immediately. Only once all monitored parameters are within the permissible limits and the remote shutdown is deactivated, R1 and R2 switch on again after a defined turn-on time.

R1 and R2, together with the connected isolating contactors (A and B), ensure the required mains separation (generating system - public mains) when a protective function is triggered.

The switching actions of the isolating contactors are also monitored by the feedback contacts of the isolating contactors, which are connected to the digital inputs of the URNA0345-B, which further increases plant safety.

Make sure that the feedback contacts of the isolating contactors A/B are correctly connected. Menu item 1.040 provides information about the status of contactors A and B (DI1 and DI2). The feedback contacts may have to be re-parameterised to menu item 3.099 (n.c. versus n.o.). Another source of error are the masses of the digital inputs I1 and I2, which are not connected internally and must therefore always be connected externally.

Both relays R1 and R2 LEDs dark means that R1 and R2 are OFF (inoperative):

1.040	df1t	60			
Toff	---	ms			
DI1	DI2	DI3	DI4	DI5	
1	1	0	0	0	



The digital inputs DI1(2) signal a closed feedback contact of the isolating contactors with "1". If n.c. (normally closed) is selected for parameter 3.099, the wiring is correct.

However, if the digital inputs DI1(2) are monitoring "0", an open feedback contact of the contactors as in the following display is recognized.

1.040	df1t	60			
Toff	---	ms			
DI1	DI2	DI3	DI4	DI5	
0	0	0	0	0	

In this case parameter 3.099 must be changed to n.o. (normally open), or the wiring between the isolating contactors A/B and the digital inputs has not been carried out correctly.

Table of parameter 3.099:

Type of contactor of auxiliary contact			Parameter 3.099 (setting value)
Contact type	Contact designation	Symbol	
Normally open contact (n.o.)	13/14, 23/24, 33/34, ...		n.o.
Normally closed contact (n.c.)	11/12, 21/22, 31/32, ...		n.c.

3.4 Protection functions / comparators

Depending on the selected parameter set, certain protection functions / comparators are editable.

3.4.1 Voltage monitoring

Line to line 59.S1 59.S2	Overvoltage 1 Overvoltage 2	All 3 phase to phase voltages are monitored according to the set overvoltage thresholds. If the threshold is exceeded, R1 and R2 switch to OFF after the set response delay t_{off} . Line to line monitoring is deactivated in 2-phase (L+N) and 4-phase (L1, L2, L3+N) connection mode!
Line to line 27.S1 27.S2	Undervoltage 1 Undervoltage 2	All 3 phase to phase voltages are monitored according to the undervoltage thresholds set. When falling below the threshold, R1 and R2 switch to OFF after the set response delay t_{off} . Line to line monitoring is deactivated in 2-phase (L+N) and 4-phase (L1, L2, L3+N) connection mode!
Line to Neutral 59.S1 59.S2	Overvoltage 1 Overvoltage 2	All 3 phase-to-neutral voltages are monitored according to the overvoltage thresholds set! If the threshold is exceeded, R1 and R2 switch to OFF after the set response delay t_{off} . Exception: In 2-phase (L+N) connection mode, overvoltage monitoring only takes place between L1 and N! Line to Neutral monitoring is deactivated in 3-phase (L1, L2, L3) connection mode!
Line to Neutral 27.S1 27.S2	Undervoltage 1 Undervoltage 2	All 3 phase-to-neutral voltages are monitored according to the undervoltage thresholds set! When falling below the threshold, R1 and R2 switch to OFF after the set response delay t_{off} . Exception: In 2-phase (L+N) connection mode, overvoltage monitoring only takes place between L1 and N! Line to Neutral monitoring is deactivated in 3-phase (L1, L2, L3) connection mode!
Average 59-AV	Overvoltage	The calculated 10-minutes average is monitored according to the thresholds set for the slow voltage increase protection. If the threshold is exceeded, R1 and R2 switch to OFF after the set response delay t_{off} . In 2-phase coupling mode: L-N In 3-phase coupling mode: L1-L2-L3 In 4-phase coupling mode: L1-N; L2-N; L3-N
U (Zero Sequence) Uzero Line to Neutral Line to line 59V0	Overvoltage	All 3 line-to-neutral voltages are added with magnitude and phase position. This resulting voltage (zero sequence) is determined in terms of magnitude to the neutral conductor and subsequently divided by three. If the threshold is exceeded, R1 and R2 switch to OFF after the set response delay t_{off} . The zero sequence is only activated in the 4-phase (LN +LL) connection mode!
U (resulting) Ures Line to Neutral Line to line	Overvoltage	Activation of the narrower frequency window when the threshold of 3 x Zero Sequence is exceeded after the set response delay t_{off} . Ures is only activated in the 4-phase (LN +LL) connection mode!

U (activation narrower frequency window) Uanf Line to Neutral	Undervoltage	All 3 line-to-neutral voltages are monitored according to the set undervoltage thresholds. If the value falls below the threshold, the narrower frequency window is activated after the set response delay t_{off} .
---	--------------	---

3.4.2 Frequency monitoring

Overfrequency 1 Overfrequency 2 Overfrequency 3 Overfrequency 4 81O.S1, 81O.S2, 81O.S3, 81O.S4	The frequency of the 3 phase-to-neutral voltages is monitored according to the overvoltage thresholds set. If the threshold is exceeded, R1 and R2 switch to OFF after the set response delay t_{off} . Exception: in 2-wire mode only U L1-N is monitored
Underfrequency 1 Underfrequency 2 Underfrequency 3 Underfrequency 4 81U.S1, 81U.S2, 81U.S3, 81U.S4	The frequencies of the 3 phase-to-neutral voltages are monitored according to the under-frequency thresholds set. When falling below the threshold, R1 and R2 switch to OFF after the set response delay t_{off} . Exception: in 2-wire mode only U L1-N is monitored
Random over frequency	The frequency of the 3 phase-to-neutral voltages is monitored according to the parameters set (random max. frequency). If the threshold is exceeded, R1 and R2 switch to OFF after the set response delay t_{off} . Exception: in 2-wire mode only U L1-N is monitored
Frequency monitoring undervoltage LL Frequency monitoring undervoltage LN	Depending on the connection mode (2-, 3-, 4-wire) falling below the set threshold leads to the deactivation of the frequency monitoring.
RoCoF 81R	The rate of change of frequency of the 3 phase-to-neutral voltages are monitored according to the parameters set. If the threshold is exceeded, R1 and R2 switch to OFF after the set response delay t_{off} . Exception: in 2-wire mode only U L1-N is monitored

3.4.3 Phase shift monitoring

Phase Shift 78	The phase shift behavior of the 3 phase-to-neutral voltages is monitored according to the parameters set. If the threshold is exceeded, R1 and R2 switch to OFF after the set response delay t_{off} . Exception: in 2-wire mode only U L1-N is monitored
-----------------------	---

3.5 Loss Of Mains (Microgrid) detection

A Microgrid is a locally defined electricity main that consists of only one or a few electric generators, supplying only a small area and is no longer connected to other electric grids.

3.5.1 Loss Of Mains (Microgrid) detection via voltage measurement

In this process, a microgrid is detected via 3-phase voltage monitoring (line-to-line).

3.5.2 Loss Of Mains (Microgrid) detection via RoCoF

In this process, a microgrid is detected via rate of change of frequency. This measurement is based on frequency measurements and triggers in the event of lasting frequency changes over multiple periods. The df/dt limit is specified and set in mHz/s.

3.5.3 Loss Of Mains (Microgrid) detection via vector shift

In this procedure, a phase or vector shift is detected via time measurements of the half-waves and the comparison with previous measurements. A vector jump can occur due to a sudden load change or shortcuts in the superordinate mains. The limit is specified and set in degrees (0,1 etc.).

3.6 Test function

The test function can be activated in two different ways:

- Pressing the ESC key in any display of menu level 1
- Pressing the ENT key in menu item 1.050

Both output-relays R1 and R2 are switched off activating the test function and the turn-on time begins to run.

As with every turn-off, the turn-off time in the test function is determined. The last turn-off time can be read out in menu item 1.040 (Toff).

3.7 Digital inputs

The actual state of the digital inputs can be seen with menu item 1.040.

The different \perp for the digital inputs are not connected to each other internally, so they all must be connected individually when used.

Digital inputs 1 and 2 (each with \perp) serve as feedback contacts of both isolating contactors A and B. They are driven via the auxiliary contact of the isolation contactors. Here, the auxiliary contact must be connected as normally opened or normally closed and the digital inputs must be configured accordingly in menu item 3.099 of the device. The different \perp for the digital inputs are internally not connected to each other, so they must be connected individually when used.

The digital input 3 (I3 and \perp) serves for remote shutdown. Menu item .114 (I3 STOP) is by default n.o. (normally open). In this case R1 and R2 switch off by bridging I3 with \perp . Changing menu item .114 to n.c. (normally closed), I3 must be bridged with \perp for normal operation (R1 and R2 switched on). By opening I3 from \perp , R1 and R2 are switched off and thus also the connected contactors A and B. Disabling .114 (dis.) no remote shutdown can be performed.

Both digital inputs 4 and 5 are used for parameter switching for Italian standard CEI 0-21. Digital input 5 is used to activate the narrower frequency window for the Belgian and European parameter sets C10/11:2021 and EN50549-1/2:2019.

3.8 Output relays R1, R2 and R3

The two output relays R1 and R2 trigger the isolating contactors/coupling switches. If the public mains is measured and found to be OK by the URNA0345-B, the generating unit may supply in. Therefore R1 and R2 switch state to ON (LED R1 and LED R2 light up). The connected isolating contactors at 11-14 (21-24) are actuated and connect the generating unit to the power grid.

If measured line-to-neutral/line-to-line voltages, mains frequency (or RoCoF, Pshift, Uzero) move outside their defined thresholds, a protection function is activated. In this case R1 and R2 switch to OFF, which opens the isolating contactors 11-14 (21-24), thus disconnecting the generating unit from the public mains.

The output relay R3 is handled country-specific. This allows error states (violations of the protective function, incorrectly configured/wired feedback contacts) to be evaluated. Depending on the error case for which R3 is configured, it switches state to ON in the event of an error (LED R3 lights up). An error occurs if, for example there is an overvoltage error or the feedback contacts are not connected correctly.

3.9 Error

Latest errors are displayed in level "1.060 Error," the display of the error memory is located in level 2. There is a difference between Measurement errors and system errors as follows:

3.9.1 Measurement error

```
1.060 Error
M: UΔ UY Ū f Δf ΔΦ C
S: T0123456789ABCDEF
   ENT ->
```

Only the current present error is shown here!

Error types:

- UΔ Phase to phase voltage error (under or overvoltage)
- UY Phase-to-neutral voltage error (under or overvoltage, Zero Sequence)
- Ū 10-minute average voltage error
- f Frequency error (under or over frequency)
- Δf Frequency ramp error (RoCoF)
- ΔΦ Phase shift error (PShift)
- C Feedback contact error – Contactor falsely closed
- c Feedback contact error – Contactor falsely opened

3.9.2 System error

```
1.060 Error
M: UΔ UY Ū f Δf ΔΦ C
S: T0123456789ABCDEF
   ENT ->
```

Error types:

- T Remote shutdown active
- 0-9, A-F If this error appears permanently, please contact our technical support.

System error entries are found in the error memory when the unit is delivered. These are caused by the factory due to final tests of the device, in which these errors are induced on purpose. As the error memory cannot be deleted, these entries do not represent a device error and can simply be ignored.

3.9.3 Error memory (LOG)

The error memory (for max. 50 LOGs) is displayed in level 2.

In the error memory, both the occurrence and the disappearance of each error are stored with a time stamp. Entries without an error code is therefore not a malfunction.

```
2.0nn Error
M: UΔ UY Ū f Δf ΔΦ C
S: T0123456789ABCDEF
t: 9999d 15h 03m 01s
```

- nn ... The number of the entry in the error memory
- t ... Timestamp: duration since occurrence in days/hours/minutes/seconds

3.10 Novelties concerning country-specific parameter sets

3.10.1 VDE-AR-N 4105:2018

For the 3 parameter sets of VDE-AR-N 4105 (ID:311,312,313), the following applies for commissioning:

When commissioning, make sure that only one coupling switch (at R1) is to be used. VDE-AR-N 4105 for inverters is an exception - here, 2 coupling switches (at R1 and R2) must still be used.

Furthermore, the feedback contact(s) must be connected to the digital inputs I1(2) and \perp provided for this purpose. Finally, parameter 3.099 determines whether the feedback contact(s) are normally closed (n.c.) or normally open (n.o.).

An Error C (Contact) appears on the display if this has not been taken into account. URNA0345-B must not switch on the output relays R1 and R2 for VDE-AR-N 4105 during Error C as long as the feedback contacts are not correctly connected and parameterised.

Contact Error-Reset:

If U_N 3x400V AC is properly applied, a reset can only be performed by pressing Esc (level 1.010) or Ent (level 1.050). The contact error is thereby deleted and the output relays R1 and R2) pick up after the switch-on time has elapsed.

An existing contact error can also be reported to the generating unit via R3.

In this context, we would like to refer to chapter 3.7 Test function (determining the tripping time of the coupling switch).

New parameter T ConDelOn:

By means of synchronising devices or circuit breakers, it is permitted that after the release by the NA protective relay, the coupling contactor(s) are only switched on with a delay. Therefore, the feedback from the feedback contact is also delayed. The permissible response delay is defined with the **parameter 3.110. T ConDelOn**. In the default setting, this time is parameterised with **100ms** and can be set up to a maximum of 300,000ms (5min). Conformity is guaranteed up to 10.000ms.

Criteria for used coupling switch:

With the set 100ms trigger time for the different protective functions, the maximum trigger time of the URNA0345-B is 119ms with the **German parameter sets**. To ensure the total tripping time of ≤ 200 ms (URNA0345-B + coupling switch), **the coupling switch** used must be able to trip **within 81ms**.

Password protection:

With regard to VDE-AR-N 4105, the appliances are provided with fixed password protection upon delivery. The password is "4105". The commissioning engineer is requested to change the password immediately for security reasons (see 5.2.5)

3.10.2 C10/11:2021

Zero Sequence protection function:

The detection of the zero sequence (U_{zero}) in the three-phase system forms a further supplement to the protection functions. Zero sequence can be used, for example, to detect short circuits in the superordinate medium power grid. For this purpose, the three line-to-neutral voltages L1, L2 and L3, which are normally shifted by 120° , both the magnitude and the phase position are added to each other. The magnitude of the voltage difference (without angle) to the neutral conductor is determined and divided by three.

If all line-to-neutral voltages have the same magnitude and are shifted exactly 120° to each other, the zero sequence is 0VAC.

In the currently valid version of the C10/11, the threshold value for zero sequence is defined with 20% U_n (46VAC). If this limit is exceeded for $>1.5s$, R1 and R2 switch off and do not switch on again after the T_{on} delay has elapsed until the zero sequence falls below 15% U_n (34.5VAC). The corresponding parameters can be found in parameter set ID:603 from 3.115 to 3.118 (see appendix).

Connection Mode 4-wire (LN+LL) is required to determine the zero sequence. This is activated by default in parameter set ID 603 for C10-11:2021 LV-IP and must not be changed by the local mains operator if the Zero Sequence protection function is mandatory. In parameter set ID 653 for C10-11:2021 HV-IP, the determination of the zero sequence must be individually discussed with the local mains operator and set accordingly.

For error-free detection of the zero sequence, none of the 3 angles (Φ_1 , Φ_2 or Φ_3) between L1, L2 and L3 must not exceed $>180^\circ$. Furthermore, the direction of rotation of the 3 phases L1- \rightarrow L2- \rightarrow L3 must be strictly ensured. For this purpose, L1, L2 and L3 of the power grid must be connect parallel to the phases L1, L2 and L3 of the URNA0345-B in this order. To detect the zero sequence, the neutral conductor must be connected (also due to Connection Mode 4-wire (LN+LL)).

Activation of narrower frequency window:

This is based on 2 criteria of locally prevailing voltages in Microgrids. In the event of a response, a narrower frequency window $<49.7Hz$ and $>50.3Hz$ (500ms) is monitored in addition to the normal frequency monitoring $\leq 47.5Hz$ and $\geq 51.5Hz$ ($<100ms$), thus forming a further protection function for shut down R1 and R2 for mains disconnection.

1. Criterion: Activation of the narrower frequency window on exceeding $U_{res-anfw} > 5\% U_n$ ($U_{res-anfw} = 3 * U_{zero}$). Related parameters for deactivation, for example, starting from 3.119 to 3.122.
With this criterion, it should be noted that even the smallest changes in one of the line-to-neutral voltages $<218.5VAC$ (for $U_n = 230VAC$) or an angular change in one of the line-to-neutral voltages of $>2.87^\circ$ result in the activation of the narrower frequency window.
2. Criterion: Activation of the narrower frequency window when one of the line-to-neutral voltages is below 85%. This criterion replaces the measurement of the rotating and counterrotating symmetrical components of the 3-phase system. Related parameters for deactivation, for example Starting with 3.123 to 3.126.

Another possibility to activate the narrower frequency window is to bridge the digital input I5 with \perp in order to be able to connect further measurement options here, as recommended in EN50549-1:2019 + AC:2019 (see connection diagram 4).

Important!

The settings for activating the narrower frequency window (3.062 to 3.069 and 3.119 to 3.126) must be agreed and documented with the local network operator.

3.10.3 EN50549-1/2:2019 (default Netherlands)

For the European EN50549-1/2 parameter set, the same requirements apply for the activation of the narrower frequency window as in chapter 3.10.2. However, the corresponding parameters (3.062 to 3.069 and 3.119 to 3.126) are deactivated and must be parameterised after consultation with the local network operator. Furthermore, the protection function Zero Sequence can also be activated in the parameter sets of EN50549-1/2 as mentioned in 3.10.2.

The default settings in the parameter set are designed for the standard protection functions of the Netherlands.

3.10.4 OPEN_SETUP

Within the parameter set OPEN_SETUP, voltage threshold values for the deactivation of all 3 possible frequency monitorings can now be activated. Activation/deactivation is done with parameter 3.046 for LL measurements and parameter 3.050 for LN measurements. With 3.047 (for LL) or with 3.051 (for LN), the voltage thresholds for deactivating the frequency monitors can be set. In most countries, these are around 20%Un. The hysteresis for the reactivation is automatically defined with 1%.

With OPEN_SETUP, the Zero Sequence can also be activated as the activation of narrower frequency band.

4 Operation and commissioning

Initial commissioning

The device is delivered without a pre-configured country specific parameter set. During initial commissioning, the device will prompt to select a parameter set (level 5 - menu item 5.001). Here, the corresponding configuration/standard must be selected via +/- and confirmed with ENTER.

You can find more information in the menu structure.

4.1 Menu navigation

The display unit consists of a 4-line text display with 20 characters per line.

The display has 5 levels. The different displays of the levels can be navigated via + and -.

4.1.1 Level 0

Start display (Display for 5 seconds during power up)

Basic information is displayed here (for example SW-Version and device-ID). This display appears after power-up and remains visible for 5 s. Then the display jumps to the first window in level 1.

4.1.2 Level 1

Measurements (Display 1.010-1.032)

Display of the current measurements.

Additionally, it will also be displayed here if the parameter set corresponds to the default configuration (dflt - default = base or factory setting). Was a parameter edited within the normative permissible limit values (edit - edited), or was set outside the normative permissible limit values (ncnf - non conform = does not comply with the regulations or the selected standard).

The expiring timer of Ton delay can also be read out in menu item 1.010 (in seconds).

Navigation +/- . From these displays, pressing the ENT-key takes you to level 3.

Digital inputs and turn-off time (Display 1.040)

Displays the actual states of the digital inputs and the last turn-off time (Toff) of the connected contactors (the larger value for two-channel systems).

Test/Reset (Display 1.050)

A relay test is triggered by pressing the ENT key. In this test, relays A and B turn off and the "reconnection-timer" (turn-on time) begins to run.

Also, a reset event can be carried out with the test/reset function, which allows relay 1/2 to be switched on again after a contact error (C) (required for the three-parameter sets VDE-AR-N 4105). The test/reset event can also be performed by pressing the ESC key in level 1.

Error (Display 1.060)

Display of current error:

M	Measurement error
S	System error

Navigation +/- . Access level 2 by pressing the ENT key.

4.1.3 Level 2

Error memory

This is where the latest errors are displayed with a timestamp (time since occurrence). The time is only counted when the device is powered. Both positive, as well as negative error flanks, are saved and displayed.

Navigation +/- . From this screen, you can access level 1 via ESC.

4.1.4 Level 3

Parameter display

Here, the parameters that have been visibly switched for the corresponding configuration are displayed.

Navigation +/- . From this screen, you can access level 1 via ESC.

You can access the editing mode of the selected parameter via PROG (can be lead-sealed).

The password query is skipped if the password is "0000" and you will end up directly in editing mode in level 5.

If a valid password has been entered in the last 60 seconds, the password query is skipped and you will end up directly in level 5.

If a password other than "0000" has been defined, you will be asked for the password in level 4.

4.1.5 Level 4

Password input

The currently active digit of the password can be incremented/decremented (0...9) via +/-.

ENT jumps to the next digit of the password entry.

The entered password is checked after pressing ENT in the 4th position.

ESC jumps back to the previous digit of the password entry.

The program goes back to Level 3 when you press ESC at the first digit of the password.

If you have forgotten the password, please contact our technical support and let them know the device ID. You will receive a master password only relevant to your device.

4.1.6 Level 5

Parameter editing

In this level, the parameter previously selected in level 3 can be changed with +/-.
Confirm with ENT or use ESC to discard the change. In both cases, the display jumps to the corresponding parameter in level 3.

Additionally, it will also be displayed here whether the value that was just edited corresponds to the default configuration (dflt - default = base or factory setting) if it was edited within the normative permissible limit values (edit - edited) or is set outside the normative permissible limit values (ncnf - non conform = does not comply with the selected regulation or the selected standard).

Alongside thresholds, times, and modes, the 4 digits of the password also have 1 parameter each.

The current standard is a parameter too. This means that a newly selected standard will be activated by changing this parameter. Therefore, all previous changes will be discarded.

If the already set standard is selected, the standard will be reset to default.

4.2 Operating menu structure

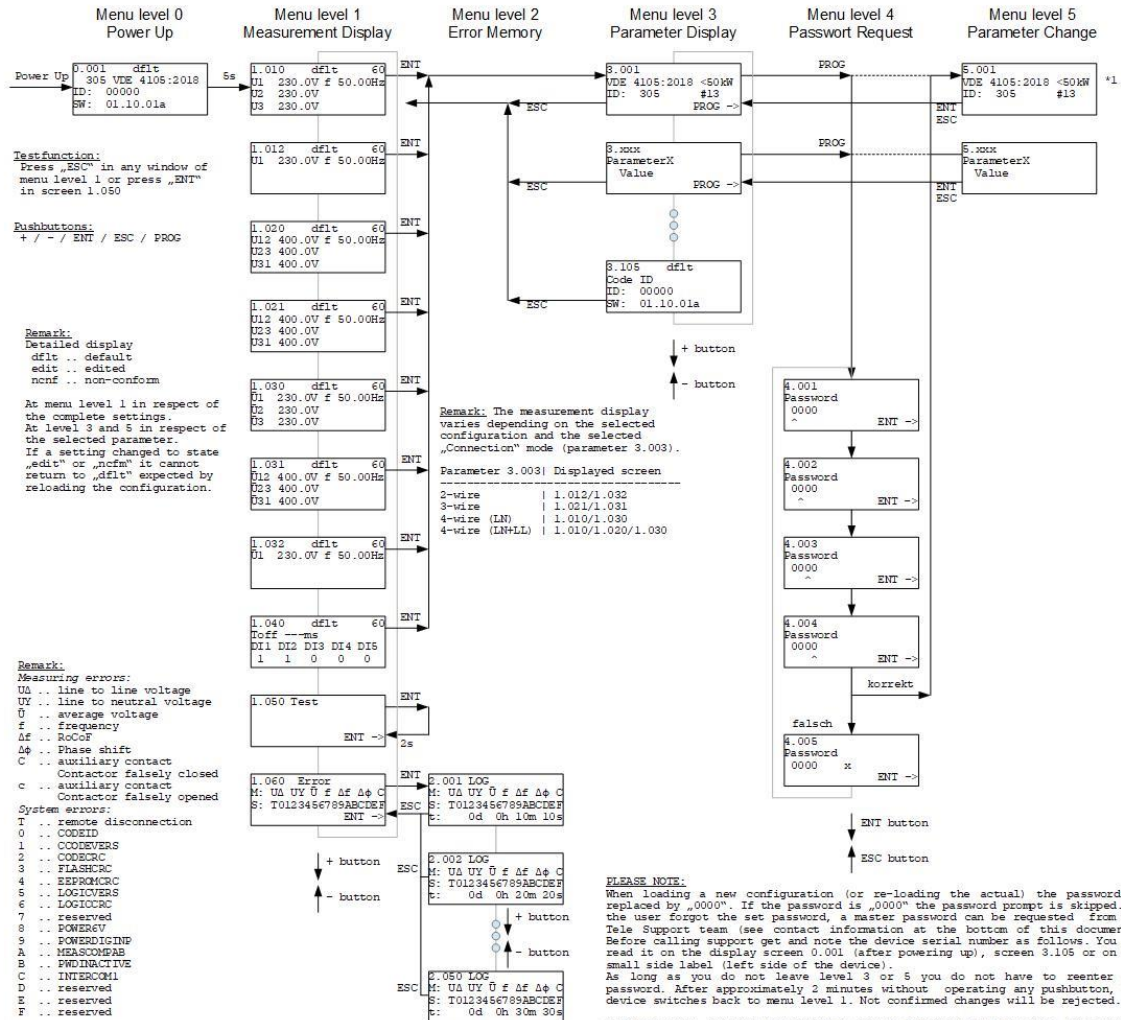

4.3 Lead seal

After commissioning, the device is to be secured against unauthorized changes of the protection-relevant setting parameters via a configurable password! If password protection is not used or if the country-specific regulations or standards demand it, the device is to be lead-sealed!

4.4 Use cases

4.4.1 Use of voltage transformers in medium power mains (OVE TOR R25, OOE TOR R25)

Using Austria as an example, in medium voltage networks a distinction is made between two basic voltage levels:

21kV and [31.7kV for special cases e.g. wind farms] phase to phase voltage.

Use of a 200:1 voltage converter at $U_c = 21\text{kV}$:

1. Select the parameter set **852** (OVE/OOE TOR R25 MS SYNC) for synchronous or **853** (OVE/OOE TOR R25 NS ASYNC) for non-synchronous generating systems (converter).
2. Parameter .005 (setting the nominal voltage ULN/LL nom) to **60.4/105.0V**.
Mathematically, the value results from $21\text{kV}/200 = 105\text{V}$ (the 60.4V stand for the phase to neutral voltages, which are not relevant for medium-voltage applications). The setting options are possible as described with **60.4/105.0V**.

Use of a 200:1 voltage converter at $U_c = 31,7\text{kV}$ (e.g. wind farms):

1. Select the parameter set **852** (OVE/OOE TOR R25 MS SYNC) for synchronous or **853** (OVE/OOE TOR R25 NS ASYNC) for non-synchronous generating systems (converter).
2. Parameter .005 (setting the nominal voltage ULN/LL nom) to **91.0/158.1V**.
Mathematically, the value results from $31.7\text{kV} / 200 = 158.5\text{V}$ (the 91.0V stand for the phase to neutral voltages, which are not relevant for medium-voltage applications). The setting options are possible as described with **91.0/158.1V**.

Use of a 300:1 voltage converter at $U_c = 31,7\text{kV}$ (e.g. wind farms):

1. Select the parameter set **852** (OVE/OOE TOR R25 MS SYNC) for synchronous or **853** (OVE/OOE TOR R25 NS ASYNC) for non-synchronous generating systems (converter).
2. Parameter .005 (setting the nominal voltage ULN/LL nom) to **60.4/105.0V**.
Mathematically, the value results from $31.7\text{kV}/300 = 105.6\text{V}$ (the 60.4V stand for the phase to neutral voltages, which are not relevant for medium-voltage applications). The setting options are possible as described with **60.4/105.0V**.

In any case, the following applies: All protective functions $U_{>>}$, $U_{>}$, $U_{<<}$, $U_{<}$ automatically adjust to the newly set voltage levels, this means changes only need to be made if they do not meet the requirements of the network operator.

Changing the protective function $U_{>}$ and $U_{>>}$ according to the specifications of the network operator:

In the delivery state (default), these thresholds for $U_{>}$ off are $1.06 \times U_c$ (106%) and for $U_{>>}$ off $1.1 \times U_c$ (110%). If the network operator requests settings for $U_{>}$ off for example $1.04 \times U_c$ (104%) and $U_{>>}$ off for example $1.15 \times U_c$ (115%), both parameters .011 and .027 must be adjusted. If there are also different specifications for the undervoltage thresholds, parameters .015 ($U_{<}$ off) and .031 ($U_{<<}$ off) must also be adjusted.

Note: In low-voltage networks, the nominal voltage is designated U_n and in medium voltage networks U_c .

4.4.2 FRT (Fault Ride Through) capability of generators:

The FRT capability must be considered separately for the different components of power generation equipment. The FRT capability of isolating contactors is described in chapter 2.6. The installer of the power generation system must ensure that sufficient buffering is available for the isolating contactors.

The installer of the power generation plant must also ensure that the requirements from the FRT (different requirements between countries) and the protection settings for undervoltage ($U < U_{<<}$ and Time OFF) do not affect each other.

If the URNA0345-B (A1/A2) is supplied by the measuring circuit (not supplied separately from the measuring circuit), it can be guaranteed that the following FRT requirements from TOR 1.1 and VDE-AR-N 4105: 2018 can be run through without any problems (even at short intervals) while the output relays R1/R2 do not switch off erroneously due to the internal power supply unit.

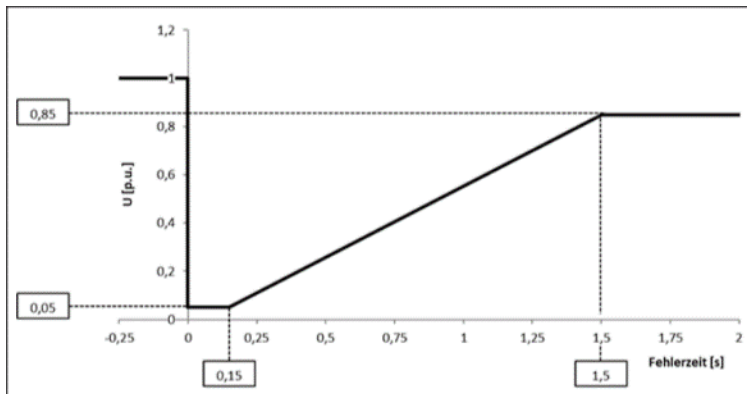

(FRT-profile of asynchronous generators at middle voltage according to TOR 1.1 2019; the most difficult FRT behavior was chosen)

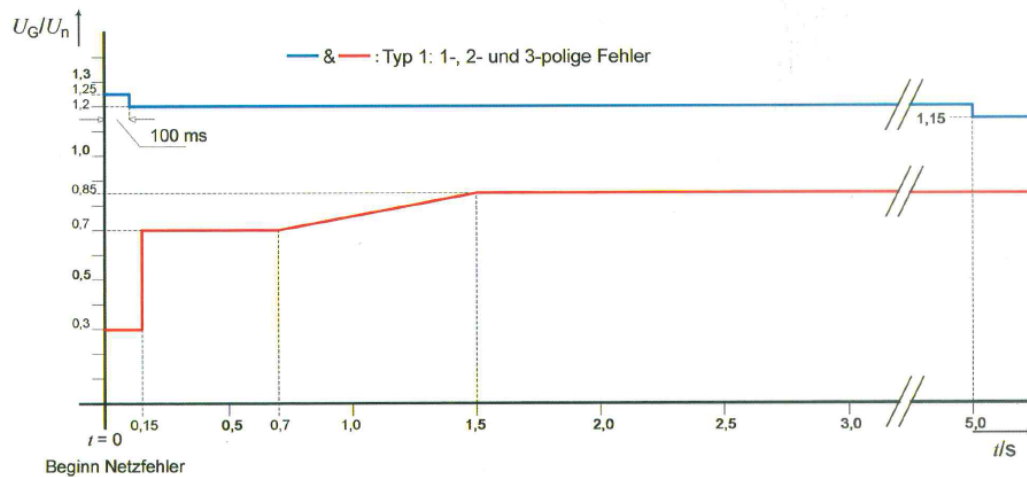

Legende

- & — FRT-Kurve für 1-, 2- und 3-polige Netzfehler
- U_G Effektivwert der aktuellen Spannung an den Generatorklemmen

(FRT profile according to VDE-AR-N 4105:2018 Type1- synchronous generators only)

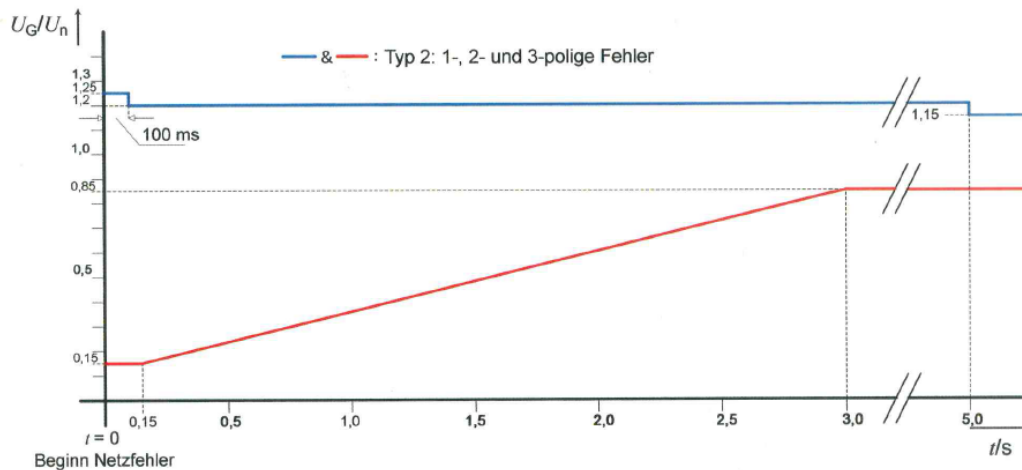

Legende

- & — FRT-Kurve für 1-, 2- und 3-polige Netzfehler
- U_G Effektivwert der aktuellen Spannung an den Generatorklemmen

(FRT profile according to VDE-AR-N 4105:2018 Type2- converter and others)

This FRT behavior applies to the entire AC supply range 110-230VAC. For a supply with 24VDC, the FRT behavior (no dropout of the output relays R1/R2) is not guaranteed. In this case, the power plant installer must ensure that the 24VDC is adequately buffered (device consumption 1.25W / 4VA).

In case of a total power loss for example L1 goes offline, and A1 & A2 are connected to L1 and N, the internal PSU bridges the gap. The NA protection relay does not reset and the relays R1 & R2 do not switch off.

Buffer times are defined as follows:

230VAC <580ms

110VAC <200ms

24VDC < 70ms (NA protection supplied externally)

However, the internal buffering only takes the URNA0345-B into account. In case of URNA0345-B A1/A2 is also connected to the isolating contactors on A1/A2, a separate calculation of the internal consumption of the isolating contactors must always be done.

4.4.3 Self retention for remote shutdown with manual reset

For special applications, the network operator may require a manual reset after a remote shutdown. This is currently possible through the implementation of a self-retaining circuit:

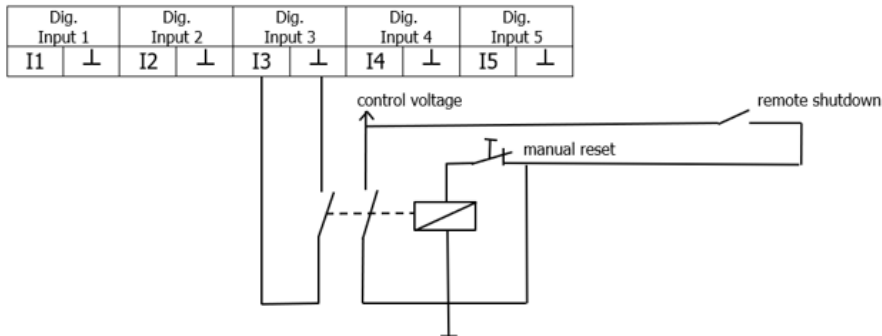

4.4.4 Connection of a load management device for power reduction 0%

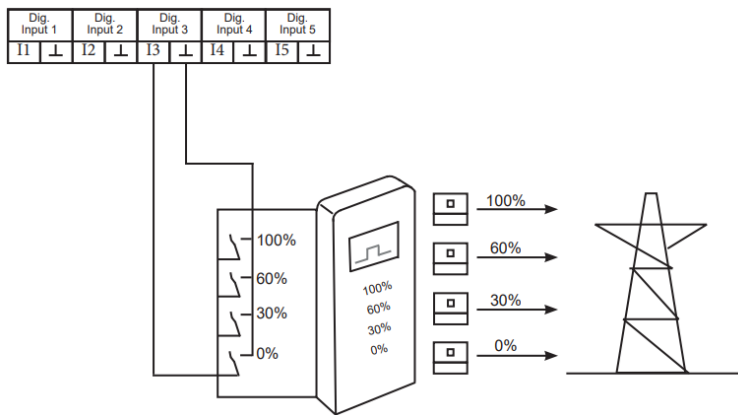

4.5 Supply circuit

Terminals	A1 (L or +); A2 (N or -)
Supply voltage	DC: 24V AC: 110 - 230V
Tolerance of the supply voltage	DC: $\pm 10\%$ AC: $\pm 30\%$
Nominal consumption	max. 1,25W / 4VA @ 230V AC
Nominal frequency	50 / 60Hz
Tolerance of the nominal frequency	48 - 63Hz
Duration of operation	100%
Recovery time	6 seconds + set turn-on delay
Drop-out voltage	7V
Overvoltage category	III
Rated surge voltage	6 kV
Internal fusing	250V / 500mA slow blow (soldered)

To ensure the device's functionality during a power failure, the device is to be supplied via an external UPS system!

4.6 Measuring circuit

Terminals	L1-L2-L3-N
Measuring input	3x 400V AC
Input impedance	1M Ω
Measured quantities	Phase to phase voltage, phase-to-neutral voltage, 10 minutes voltage average, frequency, frequency change (RoCoF), Phase shift (PShift), Zero Sequence

4.7 Measuring ranges

Phase voltage	0 - 560VAC
Phase-to-neutral voltage	0 - 325VAC
Frequency	40 - 65Hz (measured between L1/N)
RoCoF	100mHz/s - 2.000mHz/s
PShift	1 - 15°
Overload capacity	Permanent 1,4 x U _{Nom} Impulse 1,6 x U _{Nom} (1 second)
Overvoltage category	III
Rated surge voltage	4 kV

4.8 Digital inputs

Terminals	I1 and ⊥ ; I2 and ⊥ ; I3 and ⊥ ; I4 resp. I5 and ⊥ I1, I2, I3 could be configured as n.c., n.o. and dis.
Contact type	potential-free (max. cable length 30m, laying as a control line, separate from power cables)
Switching capacity	24V DC / 5mA

4.9 Output circuit

Terminals	11-12-14; 21-22-24; 31-32-34
Number and type of contacts	3 changeover contacts
Contact material	AgNi
Switching capacity	5A / 250V AC
Electrical switching frequency (AC1-)	100 x 10 ³ switching cycles
Mechanical switching frequency	15 x 10 ⁶ switching cycles
Continuous current value	5A
Short time value (1s)	5A
Withstanding voltage across open contacts	Relay contacts: 1000V _{rms} Terminals: 450V _{rms}
Overvoltage category	III
Rated surge voltage	4 kV
Fusing	5A fast acting

4.10 Accuracy

Voltage measurement:	
Base accuracy	< 0,5% @ +25°C
Temperature effect	< 0,01%/°C
Resolution	10mV
Frequency measurement:	
Base accuracy	< 0,01Hz @ +25°C
Temperature effect	< 0,0002Hz/°C
Resolution	1mHz
Start-up Ton delay	0...600s ± 0,6%
response-delay (TIME OFF), t _{UTHR OFF}	0...300s ± 0,6%
Reset (Release) delay, t _{UTHR ON_total}	130ms ± 45%
Operating time at overvoltage t _{over}	95ms ± 50%
Operating time at undervoltage t _{under}	95ms ± 40%
Response time, t _{off_total_over/under}	t _{off_total_over} = t _{over} + t _{UTHR OFF} t _{off_total_under} = t _{under} + t _{UTHR OFF}
Overshoot time	40ms

4.11 Insulation data

Rated insulation voltage	400V
Insulation	
Supply circuit/measuring circuit	Safe isolation
Supply circuit/output circuit	Safe isolation
Supply circuit / digital inputs	Safe isolation
Output circuit/measuring circuit	Base isolation
Output circuit / digital inputs	Base isolation

4.12 Environmental conditions

Ambient temperature operation	-25 up to +65°C
Ambient temperature storage	-40 up to +70°C
Display capability	-15 up to +65°C
Relative air humidity	5 up to 95%
Degree of contamination	2
Weight	300g
MTTF	93.000h (for display temperature 25°C +/-5°C)

4.13 Electrical connection

Connection cross-section	max. 2,5mm ²
Stripping length	max. 8mm
Electrical capacity of the clamps: Relay outputs / digital inputs Measuring inputs	max. 450V/16A max. 750V/16A
Tightening torque	max. 0,5Nm
Screw	M3, screwdriver for slotted screws 0,6 x 3,5mm
Digital input circuits and output relays	No limitation for simultaneous operation of inputs and/or outputs within the specified limits

4.14 Sealing wire

Wire diameter	Ø max. 1,32mm
---------------	---------------

4.15 Protection class

Terminals	IP 20
Housing	IP 20

5 Settings of the implemented parameter sets

Definition for the following tables:

Lines highlighted in gray mean that the associated parameters can be edited. All other settings are fixed.

5.1.1 Connection Modes

2-wire	Only the voltage between L1 and N is evaluated
3-wire	Only the line to line voltages U_{L1-L2} , U_{L2-L3} and U_{L3-L1} are evaluated
4-wire (LN)	Only the phase-to-neutral voltages U_{L1-N} , U_{L2-N} , and U_{L3-N} are evaluated
4-wire (LN+LL)	Both the phase-to-neutral voltages U_{L1-N} , U_{L2-N} , and U_{L3-N} as well as the phase to phase voltages U_{L1-L2} , U_{L2-L3} , and U_{L3-L1} are evaluated

5.1.2 Units

%Unom	Percent of the nominal voltage (nominal voltage factor)
-------	---

5.1.3 Functional safety

Errtol 2ch	2 separated contactors with 2 separated auxiliary contacts are connected
Errtol 1ch	1 external contactor with 1 auxiliary contact is connected

5.1.4 Operational mode

It is possible to switch between 2 different operating modes

It is currently only used for the CEI-021

Mode 0:	transitory mode
Mode 1:	definitive mode

5.1.5 Thresholds

$U_{THR\ OFF}$	Voltage threshold for the turn-off
$U_{THR\ ON}$	Voltage threshold for turn-on
$f_{THR\ OFF}$	Frequency threshold for the turn-off
$f_{THR\ ON}$	Frequency threshold for turn-on
$RoCoF_{THR\ OFF}$	Frequency change threshold for the turn-off
$RoCoF_{THR\ ON}$	Frequency change threshold for turn-on
$PShift_{THR\ OFF}$	Phase shift threshold for the turn-off
$PShift_{THR\ ON}$	Phase shift threshold for turn-on

5.1.6 Times

Time OFF	response-delay
T on delay	Turn-on delay
F wnd	window length frequency measuring (observed time window used for determining frequency f / Hz, adjustable from 0.1s to 1s depending on the used parameter set).
RoCoF wnd	window length RoCoF (Rate of Change of Frequency) measuring (observed time window that is used to determine the RoCoF Hz / s, adjustable from 0.1s to 1s depending on the parameter set used)
PShift wnd	window length PShift (phase shift) measuring (observed time window that is used to determine the PShift / °, adjustable from 0.1s to 1s depending on the parameter set used, whereby only a setting of 0.1 to 0.6s makes sense. Pshift wnd from 0.6s to 1s does not affect the total tripping time.)
Total tripping time	This is made up of the following when measuring frequency, RoCoF or Pshift: Frequency measurement: $\text{TIME OFF total}_f = \text{Time OFF}_f + \text{F wnd}$ RoCoF measurement: $\text{TIME OFF total}_{\text{RoCoF}} = \text{Time OFF}_{\text{RoCoF}} + \text{RoCoF wnd}$ Phase shift measurement: $\text{TIME OFF total}_{\text{PShift}} = \text{Time OFF}_{\text{PShift}} + \text{PShift wnd}$

5.1.7 Auxiliary contact

Read back of the position of the actuated contactors (via positively driven auxiliary contacts) is required for the necessary functional safety. The following can be selected for these auxiliary contacts:

Contact n.c. (normally closed)	Auxiliary contact is normally opened (recommended implementation)
Contact n.o. (normally opened)	Auxiliary contact is normally closed
Contact dis. (disabled)	Auxiliary contact is ignored (impermissible for standards that require functional safety)
Contact t	Setting the time-delay (for switching off) that could elapse before the auxiliary contact of the coupling relay must feedback to I1/2, otherwise display a contact error.
T ConDelOn	Setting the time-delay (for switching on) that could elapse before the auxiliary contact of the coupling relay must feedback to I1/2, otherwise display a contact error and switch off R1/2. R3 is also activated.

5.1.8 Ranges

Conformity range	Within this range, the device is configured in compliance with the selected standards. Outside of these ranges, the device is no longer compliant with standards and the corresponding certificates lose their validity. This status is shown on the display by the identifier "ncnf." Settings outside of this range are therefore within the operator's scope of responsibility and/or the acceptance authority of the system.
Possible range	Technically possible setting range

6 Safety concept

The system consists of three microcontrollers. CH_A and CH_B are the measuring channels. These channels record, calculate and monitor the measured values, read the inputs for the feedback contacts and switch the associated relay independently. Both measuring channels are structurally redundant (e.g., voltage reference, time base). The third controller CH_D observes both measuring channels for deviations, controls the user interface (LEDs, display, keys) and non-safety-relevant inputs and outputs.

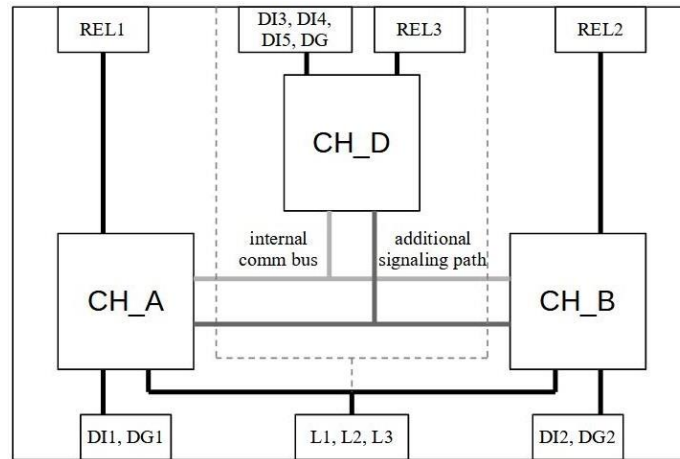

Troubleshooting

Errors are divided into three classes:

1. **Exceeded limit**

This is a normal operating condition. This includes for example the detection of overvoltage or underfrequency. These faults are handled according to the normative specification. Usually, the relays of CH_A and CH_B are switched off after a trigger delay. After the error is no longer detected and all other parameters are within the permissible limits, the relays are switched on again after a switch-on delay.

2. **Non-critical system errors**

These errors indicate a problem but are not safety critical. This includes a supply voltage that is too low or a feedback contact that is detected as open and should be closed or internal communication errors.

3. **Critical system errors**

These errors are safety-critical errors. This includes an extremely high measurement variance of the two measurement channels, thus the memory integrity is not given. If such a fault is detected, the system goes into the safety state (relay in idle state- OFF).

System error:

- T Remote shutdown activated
- 0 CH_A or CH_B contains invalid software (CODEID)
- 1 Software in CH_A and CH_B is differently (CODEVERS)
- 2 Incorrect checksum of the code memory (CODECRC)
- 3 Incorrect checksum of the firmware (currently not used - FLASHCRC)
- 4 Incorrect checksum of the EEPROM (EEPROMCRC)
- 5 Configuration is inconsistent (LOGICVERS)
- 6 Incorrect checksum of the configuration (LOGICCRC)
- 7 Allocated
- 8 Error in the supply voltage for the outputs (POWER6V)
- 9 Error in the supply voltage for the inputs (POWERDIGINP)
- A Deviation of the measuring channels (MEASCOMPAB)
- B Password request deactivated (PWDINACTIVE)
- C Measuring channel does not communicate internally (INTERCOM1)
- D Allocated
- E Allocated
- F Allocated

7 Glossary

OVE	Austrian Association for Electrical Engineering
TOR	Technical and organizational rules (Austria)
OOE	Upper Austria
W	Vienna
NS	Low voltage
MS	Medium voltage
VDE	Association of Electrical Engineering Germany
AR	Connection rules
NA/EEA- CH	Grid installations/self-generation systems-Switzerland
AS	Australia
NZS	New Zealand
DK	Denmark
IP	Interface Protection
ASS	Automatic Separation System

8 Standards and Norms available

Slot	ID	Norm/Standard	Regions	Number of channels		
				1	2 Funct. safety	1 or 2 select able
#00	802	OVE TOR R25 NS SYNC	Austria (low voltage)		X	
#01	803	OVE TOR R25 NS ASYNC	Austria (low voltage)		X	
#02	852	OVE TOR R25 MS SYNC	Austria (medium voltage)		X	
#03	853	OVE TOR R25 MS ASYNC	Austria (medium voltage)		X	
#04	822	OOE TOR R25 NS SYNC	Upper Austria Oberösterreich (low voltage)		X	
#05	823	OOE TOR R25 NS ASYNC	Upper Austria Oberösterreich (low voltage)		X	
#06	872	OOE TOR R25 MS SYNC	Upper Austria Oberösterreich (medium voltage)		X	
#07	873	OOE TOR R25 MS ASYNC	Upper Austria Oberösterreich (medium voltage)		X	
#08	832	W TOR R25 NS SYNC	Vienna (low voltage)		X	
#09	833	W TOR R25 NS ASYNC	Vienna (low voltage)		X	
#10	882	W TOR R25 MS SYNC	Vienna (medium voltage)		X	
#11	883	W TOR R25 MS ASYNC	Vienna (medium voltage)		X	
#12	812	TIROL TOR NS SYNC	Tyrol (low voltage)		X	
#13	813	TIROL TOR NS ASYNC	Tyrol (low voltage)		X	
#14	862	TIROL TOR MS SYNC	Tyrol (medium voltage)		X	
#15	863	TIROL TOR MS ASYNC	Tyrol (medium voltage)		X	
#16	311	VDE-AR-N 4105: 2018 (Pn ≤ 50kW)	Germany (low voltage)	X		

#17	312	VDE-AR-N 4105: 2018 (Pn > 50kW)	Germany (low voltage)	X		
#18	313	VDE-AR-N 4105: 2018 (converter)	Germany (low voltage)		X	
#19	706	VDE-AR-N 4110: 2018 (Pn > 135kW)	Germany (medium voltage)	X		
#20	102	CEI 0-21: 2019	Italy	X		
#21	410	G99/1/3: 2018 LV	Great Britain (low voltage)	X		
#22	460	G99/1/3: 2018 HV	Great Britain (medium/high voltage)	X		
#23	510	G98/1/2: 2018	Great Britain (low voltage)	X		
#24	603	C10-11: 2021 LV-IP	Belgium (low voltage) interface protection	X		
#25	602	C10-11: 2019 LV-ASS	Belgium (low voltage) automatic separation system	X		
#26	653	C10-11: 2021 HV-IP	Belgium (medium/high voltage) interface protection	X		
#27	652	C10-11: 2019 HV-ASS	Belgium (medium/high voltage) automatic separation system	X		
#28	1200	NA/EEA- CH 2014 (Type A)	Switzerland 2014 (low voltage)		X	
#29	1220	NA/EEA-NE7 - CH 2020 (Type A)	Switzerland 2020 (low voltage)		X	
#30	1221	NA/EEA-NE7 - CH 2020 (Type B)	Switzerland 2020 (low voltage)		X	
#31	901	EN 50549-1:2019	Europe LV (Netherlands)		X	
#32	902	EN 50549-2:2019	Europe HV (Netherlands)		X	
#33	950	EN 50438: 2013 DK	Denmark			X
#34	200	VDE V 0126-1-1:2013	France, Turkey, Belgium, Greece, ...		X	
#35	1110	AB AS 4777.2:2020	Australia		X	

#36	1120	C AS 4777.2:2020	Australia		X	
#37	1130	NZS 4777.2:2020	New Zealand		X	
#38	1000	NRS 097-2-1: 2017	South Africa		X	
#39	9006	OPEN SETUP	Freely configurable setup			X

Recertified Standards						
#52	900	EN 50438:2013	Europe		X	
#53	801	OVE E 8001/8101:2014	Austria		X	
#54	300	VDE-AR-N 4105 tested according to VDE 0124-100:2013	Germany (low voltage)		X	
#55	700	TR3 Rev23:2013 certified according to BDEW 2008	Germany (medium voltage)	X		
#56	1102	AS/NZS 4777.2:2015	Australia / Victoria (New Zealand)		X	
#57	405	G59/3/3: 2015 LV	Great Britain (low voltage)	X		
#58	455	G59/3/3: 2015 MV	Great Britain (high voltage)	X		
#59	500	G83/2: 2012	Great Britain (low voltage)	X		
#60	600	C10-11: 2012 LV	Belgium (low voltage)	X		
#61	650	C10-11: 2012 MV	Belgium medium voltage	X		
#62	601	C10-11: 2019 LV	Belgium (low voltage)	X		
#63	651	C10-11: 2019 HV	Belgium (high voltage)	X		

9 Overview of the implemented parameter sets

9.1 OVE TOR R25 NS SYNC (Typ A/B low voltage for sync. generators)

- Selectable connection mode (1-phase, 3-phase)
- Selectable nominal voltage
- Selectable feedback contact (normally closed / normally open)
- Selectable remote shutdown (normally closed / normally open)
- 2 Overvoltage threshold - phase to neutral voltage
- 2 Undervoltage thresholds - phase to neutral voltage
- 10-minute average Overvoltage threshold
- 1 Over frequency threshold
- 1 Underfrequency threshold
- switch-on delay
- Signal relay R3 - activation (LED R3 ON) when a protective function U / f responds or in the event of a feedback contact error

9.2 OVE TOR R25 NS ASYNC (Typ A/B low voltage for async. generators)

- Selectable connection mode (1-phase, 3-phase)
- Selectable nominal voltage
- Selectable feedback contact (normally closed / normally open)
- Selectable remote shutdown (normally closed / normally open)
- 2 Overvoltage threshold - phase to neutral voltage
- 2 Undervoltage thresholds - phase to neutral voltage
- 10-minute average Overvoltage threshold
- 1 Over frequency threshold
- 1 Underfrequency threshold
- switch-on delay
- Signal relay R3 - activation (LED R3 ON) when a protective function U / f responds or in the event of a feedback contact error

9.3 OVE TOR R25 MS SYNC (Typ A/B medium voltage for sync. generators)

- Selectable connection mode (1-phase, 3-phase)
- Selectable nominal voltage
- Selectable feedback contact (normally closed / normally open)
- Selectable remote shutdown (normally closed / normally open)
- 2 Overvoltage threshold - phase to phase voltage
- 2 Undervoltage thresholds - phase to phase voltage
- 1 Over frequency threshold
- 1 Underfrequency threshold
- switch-on delay
- Signal relay R3 - activation (LED R3 ON) when a protective function U / f responds or in the event of a feedback contact error

9.4 OVE TOR R25 MS ASYNC (Typ A/B medium voltage for async. generators)

- Selectable connection mode (1-phase, 3-phase)
- Selectable nominal voltage
- Selectable feedback contact (normally closed / normally open)
- Selectable remote shutdown (normally closed / normally open)
- 2 Overvoltage threshold - phase to phase voltage
- 2 Undervoltage thresholds - phase to phase voltage
- 1 Over frequency threshold
- 1 Underfrequency threshold
- switch-on delay
- Signal relay R3 - activation (LED R3 ON) when a protective function U / f responds or in the event of a feedback contact error

9.5 OOE TOR R25 NS SYNC (Typ A/B low voltage for sync. generators)

- Selectable connection mode (1-phase, 3-phase)
- Selectable nominal voltage
- Selectable feedback contact (normally closed / normally open)
- Selectable remote shutdown (normally closed / normally open)
- 1 Overvoltage threshold - phase to neutral voltage
- 2 Undervoltage thresholds - phase to neutral voltage
- 10-minute average Overvoltage threshold
- 1 Over frequency threshold
- 1 Underfrequency threshold
- switch-on delay
- Signal relay R3 - activation (LED R3 ON) when a protective function U / f responds or in the event of a feedback contact error

9.6 OOE TOR R25 NS ASYNC (Typ A/B low voltage for async. generators)

- Selectable connection mode (1-phase, 3-phase)
- Selectable nominal voltage
- Selectable feedback contact (normally closed / normally open)
- Selectable remote shutdown (normally closed / normally open)
- 1 Overvoltage threshold - phase to neutral voltage
- 2 Undervoltage thresholds - phase to neutral voltage
- 10-minute average Overvoltage threshold
- 1 Over frequency threshold
- 1 Underfrequency threshold
- switch-on delay
- Signal relay R3 - activation (LED R3 ON) when a protective function U / f responds or in the event of a feedback contact error

9.7 OOE TOR R25 MS SYNC (Typ A/B medium voltage for sync. generators)

- Selectable connection mode (1-phase, 3-phase)
- Selectable nominal voltage
- Selectable feedback contact (normally closed / normally open)
- Selectable remote shutdown (normally closed / normally open)
- 2 Overvoltage threshold - phase to phase voltage
- 2 Undervoltage thresholds - phase to phase voltage
- 10-minute average Overvoltage threshold
- 1 Over frequency threshold
- 1 Underfrequency threshold
- switch-on delay
- Signal relay R3 - activation (LED R3 ON) when a protective function U / f responds or in the event of a feedback contact error

9.8 OOE TOR R25 MS ASYNC (Typ A/B medium voltage for async. generators)

- Selectable connection mode (1-phase, 3-phase)
- Selectable nominal voltage
- Selectable feedback contact (normally closed / normally open)
- Selectable remote shutdown (normally closed / normally open)
- 2 Overvoltage threshold - phase to phase voltage
- 2 Undervoltage thresholds - phase to phase voltage
- 10-minute average Overvoltage threshold
- 1 Over frequency threshold
- 1 Underfrequency threshold
- switch-on delay
- Signal relay R3 - activation (LED R3 ON) when a protective function U / f responds or in the event of a feedback contact error

9.9 W TOR R25 NS SYNC (Typ A/B low voltage for sync. generators)

- Selectable connection mode (1-phase, 3-phase)
- Selectable nominal voltage
- Selectable feedback contact (normally closed / normally open)
- Selectable remote shutdown (normally closed / normally open)
- 2 Overvoltage threshold - phase to neutral voltage
- 2 Undervoltage thresholds - phase to neutral voltage
- 10-minute average Overvoltage threshold
- 1 Over frequency threshold
- 1 Underfrequency threshold
- switch-on delay
- Signal relay R3 - activation (LED R3 ON) when a protective function U / f responds or in the event of a feedback contact error

9.10 W TOR R25 NS ASYNC (Typ A/B low voltage for async. generators)

- Selectable connection mode (1-phase, 3-phase)
- Selectable nominal voltage
- Selectable feedback contact (normally closed / normally open)
- Selectable remote shutdown (normally closed / normally open)
- 2 Overvoltage threshold - phase to neutral voltage
- 2 Undervoltage thresholds - phase to neutral voltage
- 10-minute average Overvoltage threshold
- 1 Over frequency threshold
- 1 Underfrequency threshold
- switch-on delay
- Signal relay R3 - activation (LED R3 ON) when a protective function U / f responds or in the event of a feedback contact error

9.11 W TOR R25 MS SYNC (Typ A/B medium voltage for sync. generators)

- Selectable connection mode (1-phase, 3-phase)
- Selectable nominal voltage
- Selectable feedback contact (normally closed / normally open)
- Selectable remote shutdown (normally closed / normally open)
- 2 Overvoltage threshold - phase to phase voltage
- 2 Undervoltage thresholds - phase to phase voltage
- 1 Over frequency threshold
- 1 Underfrequency threshold
- switch-on delay
- Signal relay R3 - activation (LED R3 ON) when a protective function U / f responds or in the event of a feedback contact error

9.12 W TOR R25 MS ASYNC (Typ A/B medium voltage for async. generators)

- Selectable connection mode (1-phase, 3-phase)
- Selectable nominal voltage
- Selectable feedback contact (normally closed / normally open)
- Selectable remote shutdown (normally closed / normally open)
- 2 Overvoltage threshold - phase to phase voltage
- 2 Undervoltage thresholds - phase to phase voltage
- 1 Over frequency threshold
- 1 Underfrequency threshold
- switch-on delay
- Signal relay R3 - activation (LED R3 ON) when a protective function U / f responds or in the event of a feedback contact error

9.13 TIROL TOR NS SYNC (Typ A/B low voltage for sync. generators)

- Selectable connection mode (1-phase, 3-phase)
- Selectable nominal voltage
- Selectable feedback contact (normally closed / normally open)
- Selectable remote shutdown (normally closed / normally open)
- 2 Overvoltage threshold - phase to phase voltage
- 2 Undervoltage thresholds - phase to phase voltage
- 10 minutes average overvoltage threshold
- 1 Over frequency threshold
- 1 Underfrequency threshold
- switch-on delay
- Signal relay R3 - activation (LED R3 ON) when a protective function U / f responds or in the event of a feedback contact error

9.14 TIROL TOR NS ASYNC (Typ A/B low voltage for async. generators)

- Selectable connection mode (1-phase, 3-phase)
- Selectable nominal voltage
- Selectable feedback contact (normally closed / normally open)
- Selectable remote shutdown (normally closed / normally open)
- 2 Overvoltage threshold - phase to phase voltage
- 2 Undervoltage thresholds - phase to phase voltage
- 10 minutes average overvoltage threshold
- 1 Over frequency threshold
- 1 Underfrequency threshold
- switch-on delay
- Signal relay R3 - activation (LED R3 ON) when a protective function U / f responds or in the event of a feedback contact error

9.15 TIROL TOR MS SYNC (Typ A/B medium voltage for sync. generators)

- Selectable connection mode (1-phase, 3-phase)
- Selectable nominal voltage
- Selectable feedback contact (normally closed / normally open)
- Selectable remote shutdown (normally closed / normally open)
- 2 Overvoltage threshold - phase to phase voltage
- 2 Undervoltage thresholds - phase to phase voltage
- 1 Over frequency threshold
- 1 Underfrequency threshold
- switch-on delay
- Signal relay R3 - activation (LED R3 ON) when a protective function U / f responds or in the event of a feedback contact error

9.16 TIROL TOR MS ASYNC (Typ A/B medium voltage for async. generators)

- Selectable connection mode (1-phase, 3-phase)
- Selectable nominal voltage
- Selectable feedback contact (normally closed / normally open)
- Selectable remote shutdown (normally closed / normally open)
- 2 Overvoltage threshold - phase to phase voltage
- 2 Undervoltage thresholds - phase to phase voltage
- 1 Over frequency threshold
- 1 Underfrequency threshold
- switch-on delay
- Signal relay R3 - activation (LED R3 ON) when a protective function U / f responds or in the event of a feedback contact error

9.17 VDE-AR-N 4105:2018-11 (Pn ≤ 50 kW)

- Selectable connection mode (1-phase, 3-phase)
- Selectable feedback contact (normally closed / normally open)
- Additional monitoring of the feedback contact when switching on
- Selectable remote shutdown (normally closed / normally open)
- 1 Overvoltage threshold - phase to phase voltage
- 1 Undervoltage threshold - phase to phase voltage
- 1 Overvoltage threshold - phase-to-neutral voltage
- 1 Undervoltage threshold - phase-to-neutral voltage
- 10-minute average Overvoltage threshold
- 1 Over frequency threshold
- 1 Underfrequency threshold
- 1 random over-frequency threshold (can be activated if required)
- switch-on delay
- random switch-on delay (can be activated if required)
- Signal relay R3 - activation (LED R3 ON) in the event of a feedback contact error

9.18 VDE-AR-N 4105:2018-11 (Pn > 50 kW)

- Selectable connection mode (1-phase, 3-phase)
- Selectable feedback contact (normally closed / normally open)
- Additional monitoring of the feedback contact when switching on
- Selectable remote shutdown (normally closed / normally open)
- 1 Overvoltage threshold - phase to phase voltage
- 2 undervoltage thresholds - phase to phase voltage
- 1 Overvoltage threshold - phase-to-neutral voltage
- 2 undervoltage thresholds - phase-to-neutral voltage
- 10-minute average Overvoltage threshold
- 1 Over frequency threshold
- 1 Underfrequency threshold
- 1 random over-frequency threshold (can be activated if required)
- switch-on delay
- random switch-on delay (can be activated if required)
- Signal relay R3 - activation (LED R3 ON) in the event of a feedback contact error

9.19 VDE-AR-N 4105:2018-11 (inverter)

- Selectable connection mode (1-phase, 3-phase)
- Selectable feedback contact (normally closed / normally open)
- Additional monitoring of the feedback contact when switching on
- Selectable remote shutdown (normally closed / normally open)
- 1 Overvoltage threshold - phase to phase voltage
- 2 undervoltage thresholds - phase to phase voltage
- 1 Overvoltage threshold - phase-to-neutral voltage
- 2 undervoltage thresholds - phase-to-neutral voltage
- 10-minute average Overvoltage threshold
- 1 Over frequency threshold
- 1 Underfrequency threshold
- 1 random over-frequency threshold (can be activated if required)
- switch-on delay
- random switch-on delay (can be activated if required)
- Signal relay R3 - activation (LED R3 ON) in the event of a feedback contact error

9.20 VDE-AR-N 4110:2018-11 (tested according to TR3, evaluation report TR8)

- Selectable connection mode (1 phase, 3 phase)
- Selectable nominal voltage
- Selectable feedback contact (normally closed / normally open)
- Selectable remote shutdown (normally closed / normally open)
- 2 Overvoltage thresholds - phase to phase voltage (auto-selection depending on Connection Mode)
- 2 undervoltage thresholds - phase to phase voltage (auto-selection depending on Connection Mode)
- 2 Overvoltage thresholds - phase-to-neutral voltage (autom. selection depending on Connection Mode)
- 2 undervoltage thresholds - phase-to-neutral voltage (autom. selection depending on Connection Mode)
- 2 over-frequency thresholds
- 1 Underfrequency threshold
- switch-on delay

9.21 CEI 0-21:2019

- Selectable connection mode (1-phase, 3-phase)
- Selectable operational mode (transitory mode / definitive mode)
- Selectable feedback contact (normally opened/normally closed)
- Selectable remote shutdown (normally closed / normally open)
- 1 overvoltage threshold - phase to phase volt. (autom. selection depending on connection mode)
- 2 undervoltage thresholds - phase to phase volt. (autom. selection depending on connection mode)
- 1 overvoltage threshold - phase-to-neutral volt. (autom. selection depending on connection mode)
- 2 undervoltage threshold - phase-to-neutral volt. (autom. selection depending on connection mode)
- 10 minutes average overvoltage threshold
- 3 switchable over-frequency thresholds (switchover via operational mode and digital inputs)
- 3 switchable under-frequency thresholds (switchover via operational mode and digital inputs)
- 1 Frequency ramp threshold (RoCoF ... can be activated if required), RoCoF-Window changeable
- Selectable RoCoF window length
- Turn-on delay
- Signal relay R3 - activation (LED R3 ON) in the event of a feedback contact error

9.22 G99/1/3 LV:2018 (low voltage)

- Selectable nominal voltage
- Selectable feedback contact (normally closed / normally open)
- Selectable remote shutdown (normally closed / normally open)
- 2 overvoltage thresholds - phase-to-neutral voltage
- 1 Undervoltage threshold - phase-to-neutral voltage
- 1 Over frequency threshold
- 2 Under frequency thresholds
- 1 Frequency ramp threshold (RoCoF ... can be activated if required)
- 1 phase jump threshold (PShift ... can be deactivated if required)
- switch-on delay

9.23 G99/1/3 HV:2018 (medium/high voltage)

- Selectable nominal voltage
- Selectable feedback contact (normally closed / normally open)
- Selectable remote shutdown (normally closed / normally open)
- 2 overvoltage thresholds - phase to phase voltage
- 1 Undervoltage threshold - phase to phase voltage
- 1 Over frequency threshold
- 2 Under frequency thresholds
- 1 Frequency ramp threshold (RoCoF ... can be activated if required)
- 1 phase jump threshold (PShift ... can be deactivated if required)
- switch-on delay

9.24 G98/1/2:2018 (low voltage)

- Selectable nominal voltage
- Selectable feedback contact (normally closed / normally open)
- Selectable remote shutdown (normally closed / normally open)
- 2 overvoltage thresholds - phase-to-neutral voltage
- 1 Undervoltage threshold - phase-to-neutral voltage
- 1 Over frequency threshold
- 2 under-frequency thresholds
- 1 Frequency ramp threshold (RoCoF ... can be activated if required)
- 1 phase jump threshold (PShift ... can be deactivated if required)
- switch-on delay

9.25 C10-11 2019 LV-IP (Interface Protection / low voltage)

- Selectable connection mode (1-phase, 3-phase)
- Selectable nominal voltage
- Selectable feedback contact (normally opened/normally closed)
- Additional time monitoring of the feedback contact
- Selectable remote shutdown (normally closed / normally open)
- 2 Overvoltage threshold - phase-to-neutral voltage
- 2 Undervoltage thresholds - phase-to-neutral voltage
- 1 Overvoltage threshold Zero Sequence
- activation narrower frequency window (anfw) at Undervoltage
- activation narrower frequency window (anfw) at Zero Sequence
- activation narrower frequency window (anfw) with digital input (DI5)
- 1 Over frequency threshold
- 1 Over frequency threshold at activation narrower frequency window (anfw)
- 1 Underfrequency threshold
- 1 Underfrequency threshold at activation narrower frequency window (anfw)
- 1 Frequency ramp threshold (RoCoF ... can be activated if required)
- 1 Phase shift threshold (PShift ... can be deactivated if required)
- Turn-on delay
- Signal relay R3 - activation (LED R3 ON) in the event of a feedback contact error

9.26 C10-11 2019 LV-ASS (Automatic Separation System / low voltage)

- Selectable connection mode (1-phase, 3-phase)
- Selectable nominal voltage
- Selectable feedback contact (normally opened/normally closed)
- Additional time monitoring of the feedback contact
- Selectable remote shutdown (normally closed / normally open)
- 1 Overvoltage threshold - phase-to-neutral voltage
- 1 Undervoltage thresholds - phase-to-neutral voltage
- 10 minutes average overvoltage threshold
- 1 Over frequency threshold
- 1 Under frequency threshold
- 1 Frequency ramp threshold (RoCoF ... can be activated if required)
- 1 Phase shift threshold (PShift ... can be deactivated if required)
- Turn-on delay
- Signal relay R3 - activation (LED R3 ON) in the event of a feedback contact error

9.27 C10-11:2019 HV-IP (Interface Protection / high voltage)

- Selectable connection mode (1-phase, 3-phase)
- Selectable nominal voltage
- Selectable feedback contact (normally opened/normally closed)
- Additional time monitoring of the feedback contact
- Selectable remote shutdown (normally closed / normally open)
- 2 Overvoltage threshold - phase-to-neutral voltage
- 2 Undervoltage thresholds - phase to phase voltage
- activation narrower frequency window (anfw) at Undervoltage
- activation narrower frequency window (anfw) with digital input (DI5)
- 1 Over frequency threshold
- 1 Over frequency threshold at activation narrower frequency window (anfw)
- 1 Under frequency threshold
- 1 Underfrequency threshold at activation narrower frequency window (anfw)
- 1 Frequency ramp threshold (RoCoF ... can be activated if required)
- 1 Phase shift threshold (PShift ... can be deactivated if required)
- Turn-on delay
- Signal relay R3 - activation (LED R3 ON) in the event of a feedback contact error

9.28 C10-11:2019 HV-ASS (Automatic Separation System /high voltage)

- Selectable connection mode (1-phase, 3-phase)
- Selectable nominal voltage
- Selectable feedback contact (normally opened/normally closed)
- Additional time monitoring of the feedback contact
- Selectable remote shutdown (normally closed / normally open)
- 1 Overvoltage threshold - phase-to-neutral voltage
- 1 Undervoltage thresholds - phase to phase voltage
- 10 minutes average overvoltage threshold
- 1 Over frequency threshold
- 1 Under frequency threshold
- 1 Frequency ramp threshold (RoCoF ... can be activated if required)
- 1 Phase shift threshold (PShift ... can be deactivated if required)
- Turn-on delay
- Signal relay R3 - activation (LED R3 ON) in the event of a feedback contact error

9.29 NA/EEA- CH 2014 Type A up to 1MW (Low Voltage)

- Selectable connection mode (1-phase, 3-phase)
- Selectable nominal voltage
- Selectable feedback contact (normally closed / normally open)
- Selectable remote shutdown (normally closed / normally open)
- 2 Overvoltage thresholds - phase to phase voltage
- 1 Undervoltage threshold - phase to phase voltage
- 2 Overvoltage thresholds - phase to neutral voltage
- 1 Undervoltage threshold - phase to neutral voltage
- 10-minute average Overvoltage threshold
- 1 Over frequency threshold
- 1 Underfrequency threshold
- switch-on delay
- Signal relay R3 - activation (LED R3 ON) when a protective function U / f responds or in the event of a feedback contact error

9.30 NA/EEA-NE7 - CH 2020 Type A 800W to 250kW (Low Voltage)

- Selectable connection mode (1-phase, 3-phase)
- Selectable nominal voltage
- Selectable feedback contact (normally closed / normally open)
- Selectable remote shutdown (normally closed / normally open)
- 2 Overvoltage thresholds - phase to phase voltage
- 2 Undervoltage thresholds - phase to phase voltage
- 2 Overvoltage thresholds - phase to neutral voltage
- 2 Undervoltage thresholds - phase to neutral voltage
- 10-minute average Overvoltage threshold
- 1 Over frequency threshold
- 1 Underfrequency threshold
- 1 Frequency ramp threshold (RoCoF ... can be activated if required)
- switch-on delay
- Signal relay R3 - activation (LED R3 ON) when a protective function U / f responds or in the event of a feedback contact error

9.31 NA/EEA-NE7 - CH 2020 Type B 250kW to 36MW (Low Voltage)

- Selectable connection mode (1-phase, 3-phase)
- Selectable nominal voltage
- Selectable feedback contact (normally closed / normally open)
- Selectable remote shutdown (normally closed / normally open)
- 2 Overvoltage thresholds - phase to phase voltage
- 2 Undervoltage thresholds - phase to phase voltage
- 2 Overvoltage thresholds - phase to neutral voltage
- 2 Undervoltage thresholds - phase to neutral voltage
- 10-minute average Overvoltage threshold
- 1 Over frequency threshold
- 1 Underfrequency threshold
- 1 Frequency ramp threshold (RoCoF ... can be activated if required)
- switch-on delay
- Signal relay R3 - activation (LED R3 ON) when a protective function U / f responds or in the event of a feedback contact error

9.32 EN 50549-1:2019 LV (Netherlands)

- Selectable connection mode (1-phase, 3-phase)
- Selectable nominal voltage
- Selectable safety mode (1 contactor or 2 contactors controlled and monitored)
- Selectable feedback contact (normally opened/normally closed)
- Selectable remote shutdown (normally closed / normally open)
- 2 Overvoltage thresholds - phase to phase voltage
- 2 Undervoltage thresholds - phase to phase voltage
- 2 Overvoltage thresholds - phase to neutral voltage
- 2 Undervoltage thresholds - phase to neutral voltage
- 1 Overvoltage threshold Zero Sequence
- 10-minute average Overvoltage threshold
- activation narrower frequency window (anfw) at Undervoltage
- activation narrower frequency window (anfw) at Zero Sequence
- activation narrower frequency window (anfw) with digital input (DI5)
- 1 Over frequency threshold´
- 1 Over frequency threshold at activation narrower frequency window (anfw)
- 1 Underfrequency threshold
- 1 Underfrequency threshold at activation narrower frequency window (anfw)
- 1 Frequency ramp threshold (RoCoF ... can be activated if required)
- 1 phase shift threshold (PShift ... can be activated if required)
- Turn-on delay

9.33 EN 50549-2:2019 HV (Netherlands)

- Selectable connection mode (1-phase, 3-phase)
- Selectable nominal voltage
- Selectable safety mode (1 contactor or 2 contactors controlled and monitored)
- Selectable feedback contact (normally opened/normally closed)
- Selectable remote shutdown (normally closed / normally open)
- 2 Overvoltage thresholds - phase to phase voltage
- 2 Undervoltage thresholds - phase to phase voltage
- 2 Overvoltage thresholds - phase to neutral voltage
- 2 Undervoltage thresholds - phase to neutral voltage
- 1 Overvoltage threshold Zero Sequence
- 10-minute average Overvoltage threshold
- activation narrower frequency window (anfw) at Undervoltage
- activation narrower frequency window (anfw) at Zero Sequence
- activation narrower frequency window (anfw) with digital input (DI5)
- 1 Over frequency threshold´
- 1 Over frequency threshold at activation narrower frequency window (anfw)
- 1 Underfrequency threshold
- 1 Underfrequency threshold at activation narrower frequency window (anfw)
- 1 Frequency ramp threshold (RoCoF ... can be activated if required)
- 1 phase shift threshold (PShift ... can be activated if required)
- Turn-on delay

9.34 EN 50438:2013 (DK)

- Selectable connection mode (1-phase, 3-phase)
- Selectable nominal voltage
- Selectable safety mode (1 contactor or 2 contactors controlled and monitored)
- Selectable feedback contact (normally opened/normally closed)
- Selectable remote shutdown (normally closed / normally open)
- 2 Overvoltage thresholds - phase to phase voltage
- 1 Undervoltage threshold - phase to phase voltage
- 2 Overvoltage thresholds - phase-to-neutral voltage
- 1 Undervoltage threshold - phase-to-neutral voltage
- 1 Over frequency threshold
- 1 Under frequency threshold
- 1 frequency ramp threshold (RoCoF .. can be deactivated if required)
- Turn-on delay

9.35 VDE 0126-1-1:2013 (ERDF-NOI-RES_13E Frankreich)

- Selectable feedback contact (normally opened/normally closed)
- Selectable remote shutdown (normally closed / normally open)
- 1 Overvoltage threshold - phase to phase voltage
- 1 Undervoltage threshold - phase to phase voltage
- 1 Overvoltage threshold - phase-to-neutral voltage
- 1 Undervoltage threshold - phase-to-neutral voltage
- 10 minutes average overvoltage threshold
- 1 Over frequency threshold
- 1 Under frequency threshold
- 1 Random over-frequency threshold (can be activated if required)
- Turn-on delay
- Random turn-on delay (can be activated if required)

9.36 AB AS 4777.2:2020

- Selectable connection mode (1-phase, 3-phase)
- Selectable nominal voltage
- Selectable feedback contact (normally closed / normally open)
- Selectable remote shutdown (normally closed / normally open)
- 2 Overvoltage thresholds - phase to neutral voltage
- 2 Undervoltage thresholds - phase to neutral voltage
- 10-minute average Overvoltage threshold
- 1 Over frequency threshold
- 1 Underfrequency threshold
- 1 Frequency ramp threshold (RoCoF ... can be activated if required)
- Selectable RoCoF window length
- 1 phase shift threshold (PShift ... can be activated if required)
- Selectable Pshift window length
- Turn-on delay
- Signal relay R3 - activation (LED R3 ON) when a protective function U / f responds or in the event of a feedback contact error

9.37 C AS 4777.2:2020

- Selectable connection mode (1-phase, 3-phase)
- Selectable nominal voltage
- Selectable feedback contact (normally closed / normally open)
- Selectable remote shutdown (normally closed / normally open)
- 2 Overvoltage thresholds - phase to neutral voltage
- 2 Undervoltage thresholds - phase to neutral voltage
- 10-minute average Overvoltage threshold
- 1 Over frequency threshold
- 1 Underfrequency threshold
- 1 Frequency ramp threshold (RoCoF ... can be activated if required)
- Selectable RoCoF window length
- 1 phase shift threshold (PShift ... can be activated if required)
- Selectable Pshift window length
- Turn-on delay
- Signal relay R3 - activation (LED R3 ON) when a protective function U / f responds or in the event of a feedback contact error

9.38 NZS 4777.2:2020

- Selectable connection mode (1-phase, 3-phase)
- Selectable nominal voltage
- Selectable feedback contact (normally closed / normally open)
- Selectable remote shutdown (normally closed / normally open)
- 2 Overvoltage thresholds - phase to neutral voltage
- 2 Undervoltage thresholds - phase to neutral voltage
- 10-minute average Overvoltage threshold
- 1 Over frequency threshold
- 1 Underfrequency threshold
- 1 Frequency ramp threshold (RoCoF ... can be activated if required)
- Selectable RoCoF window length
- 1 phase shift threshold (PShift ... can be activated if required)
- Selectable Pshift window length
- Turn-on delay
- Signal relay R3 - activation (LED R3 ON) when a protective function U / f responds or in the event of a feedback contact error

9.39 NRS 097-2-1: 2017

- Selectable connection mode (1-phase, 3-phase)
- Selectable nominal voltage
- Selectable feedback contact (normally opened/normally closed)
- Selectable remote shutdown (normally closed / normally open)
- 2 overvoltage thresholds - phase to phase voltage (automatic selection depending on connection mode)
- 2 undervoltage thresholds - phase to phase voltage (autom. selection depending on connection mode)
- 2 overvoltage thresholds - phase-to-neutral voltage (autom. selection depending on connection mode)
- 2 undervoltage thresholds - phase-to-neutral voltage (autom. selection depending on connection mode)
- 1 Over frequency thresholds
- 1 Under frequency thresholds
- 1 Random over-frequency threshold (can be activated if required)
- 1 Frequency ramp threshold (RoCoF ... can be deactivated if required)
- 1 Phase shift threshold (PShift ... can be activated if required)
- Turn-on delay
- Random turn-on delay (can be activated if required)
- Signal relay R3 - activation (LED R3 ON) when a protective function U / f responds or in the event of a feedback contact error

9.40 OPEN SETUP

- Selectable connection mode (1-phase, 3-phase)
- Selectable nominal voltage
- Selectable safety mode (1 contactor or 2 contactors controlled and monitored)
- Selectable feedback contact (normally opened/normally closed)
- Selectable remote shutdown (normally closed / normally open)
- 2 Overvoltage thresholds - phase to phase voltage (automatic selection depending on connection mode, can be manually deactivated if required)
- 2 Undervoltage thresholds - phase to phase voltage (automatic selection depending on connection mode, can be manually deactivated if required)
- 2 Overvoltage thresholds - phase-to-neutral voltage (automatic selection depending on connection mode, can be manually deactivated if required)
- 2 Undervoltage thresholds - phase-to-neutral voltage (automatic selection depending on connection mode, can be manually deactivated if required)
- 1 Overvoltage threshold Zero Sequence Component (in Connection Mode 4-wire (LN+LL) only)
- 10 minutes average overvoltage threshold (can be manually deactivated if required)
- 2 over-frequency thresholds (can be manually deactivated if required)
- 2 under-frequency thresholds (can be manually deactivated if required)
- 1 Overfrequency threshold activable for narrower frequency window (NAFW) (in Connection Mode 4-wire (LN+LL) only)
- 1 Underfrequency threshold activable for narrower frequency window (NAFW) (in Connection Mode 4-wire (LN+LL) only)
- Selectable frequency window length
- 1 Random over-frequency threshold (can be activated if required)
- 1 Frequency ramp threshold (RoCoF ... can be activated if required)
- Selectable RoCoF window length
- 1 phase shift threshold (PShift ... can be activated if required)
- Selectable Pshift window length
- Turn-on delay
- Random turn-on delay (can be activated if required)
- Signal relay R3 - activation (LED R3 ON) when a protective function U / f responds or in the event of a feedback contact error
- Frequency thresholds able to be deactivated at undervoltage

9.41 EN 50438:2013

- Selectable nominal voltage
- Selectable feedback contact (normally opened/normally closed)
- Selectable remote shutdown (normally closed / normally open)
- 1 Overvoltage threshold - phase-to-neutral voltage
- 1 Undervoltage threshold - phase-to-neutral voltage
- 10-minute average Overvoltage threshold
- 1 Over frequency threshold
- 1 Underfrequency threshold
- Turn-on delay

9.42 E 8001/8101 (previous standard of OVE TOR R25)

- Selectable connection mode (1-phase, 3-phase)
- Selectable nominal voltage
- Selectable feedback contact (normally opened/normally closed)
- Selectable remote shutdown (normally closed / normally open)
- 2 Overvoltage thresholds - phase to phase voltage
- 2 Undervoltage thresholds - phase to phase voltage
- 2 Overvoltage thresholds - phase-to-neutral voltage
- 2 Undervoltage thresholds - phase-to-neutral voltage
- 10 minutes average overvoltage threshold
- 1 Overfrequency threshold
- 1 Underfrequency threshold
- Turn-on delay

9.43 VDE 0124-100:2013 (previous standard of VDE-AR-N 4105:2018-11)

- Selectable feedback contact (normally opened/normally closed)
- Selectable remote shutdown (normally closed / normally open)
- 1 Overvoltage threshold - phase to phase voltage
- 1 Undervoltage threshold - phase to phase voltage
- 1 Overvoltage threshold - phase-to-neutral voltage
- 1 Undervoltage threshold - phase-to-neutral voltage
- 10-minute average overvoltage threshold
- 1 Overfrequency threshold
- 1 Underfrequency threshold
- 1 Random overfrequency threshold (can be activated if required)
- Turn-on delay
- Random turn-on delay (can be activated if required)

9.44 TR3 Rev23:2013 (previous standard of VDE-AR-N 4110:2018-11)

- Selectable connection mode (1-phase, 3-phase)
- Selectable nominal voltage
- Selectable feedback contact (normally opened/normally closed)
- Selectable remote shutdown (normally closed / normally open)
- 1 overvoltage threshold - phase to phase voltage (autom. selection depending on connection mode)
- 2 undervoltage thresholds - phase to phase voltage (autom. selection depending on connection mode)
- 1 overvoltage threshold - phase-to-neutral voltage (autom. selection depending on connection mode)
- 2 undervoltage threshold - phase-to-neutral voltage (autom. selection depending on connection mode)
- 1 Over frequency threshold
- 1 Under frequency threshold
- Turn-on delay

9.45 AS/NZS 4777.2:2015 (low voltage)

- Local standards must be taken into account
- Selectable connection mode (1-phase, 3-phase)
- Selectable nominal voltage
- Selectable feedback contact (normally opened/normally closed/disable)
- Selectable remote shutdown (normally closed / normally open)
- 2 Overvoltage thresholds - phase-to-neutral voltage
- 1 Undervoltage threshold - phase-to-neutral voltage
- 1 Overfrequency threshold
- 1 Underfrequency threshold
- 10-minute average Overvoltage threshold
- 1 Frequency ramp threshold (RoCoF ... can be activated if required)
- Selectable RoCoF window length
- 1 Phase shift threshold (PShift ... can be deactivated if required)
- Selectable PShift window length
- Turn-on delay
- Signal relay R3 - activation (LED R3 ON) when a protective function U / f responds or in the event of a feedback contact error

9.46 G59/3/3:2015 LV (low voltage – the previous standard of G99/1/3 LV:2018)

- Selectable nominal voltage
- Selectable feedback contact (normally opened/normally closed)
- Selectable remote shutdown (normally closed / normally open)
- 2 Overvoltage thresholds - phase-to-neutral voltage
- 2 Undervoltage thresholds - phase-to-neutral voltage
- 2 Over frequency thresholds
- 2 Underfrequency thresholds
- 1 Frequency ramp threshold (RoCoF ... can be activated if required)
- 1 Phase shift threshold (PShift ... can be deactivated if required)
- Turn-on delay

9.47 G59/3/3:2015 MV (high voltage – the previous standard of G99/1/3 HV:2018)

- Selectable nominal voltage
- Selectable feedback contact (normally opened/normally closed)
- Selectable remote shutdown (normally closed / normally open)
- 2 Overvoltage thresholds - phase to phase voltage
- 2 Undervoltage thresholds - phase to phase voltage
- 2 Over frequency thresholds
- 2 Underfrequency thresholds
- 1 Frequency ramp threshold (RoCoF ... can be activated if required)
- 1 Phase shift threshold (PShift ... can be deactivated if required)
- Turn-on delay

9.48 G83/2:2012 (low voltage – previous standard of G98/1/2:2018)

- Selectable nominal voltage
- Selectable feedback contact (normally opened/normally closed)
- Selectable remote shutdown (normally closed / normally open)
- 2 Overvoltage thresholds - phase-to-neutral voltage
- 2 Undervoltage thresholds - phase-to-neutral voltage
- 2 Over frequency thresholds
- 2 Underfrequency thresholds
- 1 Frequency ramp threshold (RoCoF ... can be activated if required)
- 1 Phase shift threshold (PShift ... can be deactivated if required)
- Turn-on delay

9.49 C10-11:2012 LV (low voltage – previous standard of C10-11:2019)

- Selectable connection mode (1-phase, 3-phase)
- Selectable nominal voltage
- Selectable feedback contact (normally opened/normally closed)
- Selectable remote shutdown (normally closed / normally open)
- 1 Overvoltage threshold - phase-to-neutral voltage
- 2 Undervoltage thresholds - phase-to-neutral voltage
- 1 Over frequency threshold
- 1 Under frequency threshold
- 1 Frequency ramp threshold (RoCoF ... can be activated if required)
- 1 Phase shift threshold (PShift ... can be deactivated if required)
- Turn-on delay

9.50 C10-11:2012 MV (high voltage – previous standard of C10-11:2019)

- Selectable connection mode (1-phase, 3-phase)
- Selectable nominal voltage
- Selectable feedback contact (normally opened/normally closed)
- Selectable remote shutdown (normally closed / normally open)
- 1 Overvoltage threshold - phase to phase voltage
- 2 Undervoltage thresholds - phase to phase voltage
- 1 Over frequency threshold
- 1 Under frequency threshold
- 1 Frequency ramp threshold (RoCoF ... can be activated if required)
- 1 Phase shift threshold (PShift ... can be deactivated if required)
- Turn-on delay

9.51 C10-11:2019 LV-IP (Interface Protection / low voltage - previous standard of C10-11:2021)

- Selectable connection mode (1-phase, 3-phase)
- Selectable nominal voltage
- Selectable safety mode (1 contactor or 2 contactors controlled and monitored)
- Selectable feedback contact (normally opened/normally closed)
- Selectable remote shutdown (normally closed / normally open)
- 2 Overvoltage thresholds - phase to phase voltage
- 2 Undervoltage thresholds - phase to phase voltage
- 1 Over frequency threshold
- 1 Underfrequency threshold
- 1 Frequency ramp threshold (RoCoF ... can be activated if required)
- 1 phase shift threshold (PShift ... can be activated if required)
- Turn-on delay
- Signal relay R3 - activation (LED R3 ON) when a protective function U / f responds or in the event of a feedback contact error

9.52 C10-11:2019 HV-IP (Interface Protection / high voltage - previous standard of C10-11:2021)

- Selectable connection mode (1-phase, 3-phase)
- Selectable nominal voltage
- Selectable safety mode (1 contactor or 2 contactors controlled and monitored)
- Selectable feedback contact (normally opened/normally closed)
- Selectable remote shutdown (normally closed / normally open)
- 2 Overvoltage thresholds - phase to phase voltage
- 2 Undervoltage thresholds - phase to phase voltage
- 1 Over frequency threshold
- 1 Underfrequency threshold
- 1 Frequency ramp threshold (RoCoF ... can be activated if required)
- 1 phase shift threshold (PShift ... can be activated if required)
- Turn-on delay
- Signal relay R3 - activation (LED R3 ON) when a protective function U / f responds or in the event of a feedback contact error

10 APPENDIX

Parameters of the implemented standards in detail in another document with title:
"Parameter der implementierten Standards im Detail /
Parameters of the implemented standards in detail"