

UMG 104

Energy measurement device for DIN rails

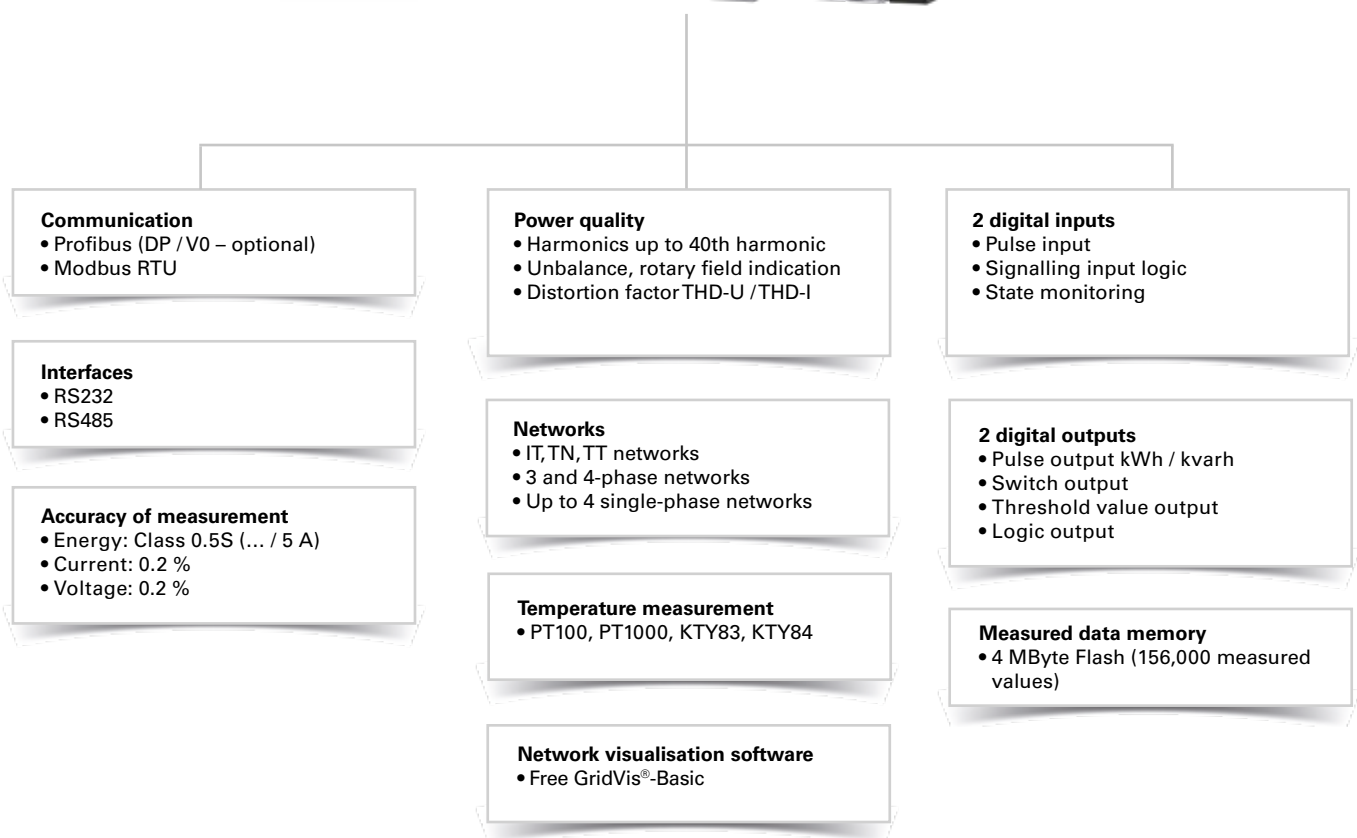



Areas of application



- Consumption data acquisition and evaluation (load profiles, load curves)
- Continuous power quality monitoring
- Cost centre accounting of energy costs
- Network protection
- Measured value transducer for building management systems or PLC

Main features



Power quality

- Harmonics analysis up to 40th harmonic
- Unbalance
- Rotary field indication
- Distortion factor THD-U / THD-I
- Measurement of positive, negative and zero sequence component

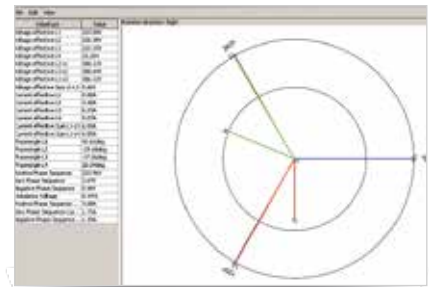

Fig.: GridVis® – Phasor diagram



High-speed Modbus

- Fast and reliable data exchange via RS485 interface
- Speed up to 921.6 kB/s

Secure and rapid communication via Modbus and Profibus

- Rapid, cost-optimised and reliable communication in existing Fieldbus architectures
- Integration in PLC systems and building management systems
- High flexibility due to the use of open standards

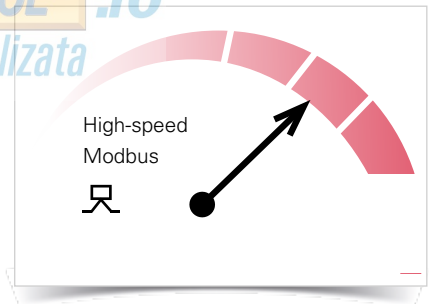

Fig.: High-speed Modbus



Large measurement data memory

- 4 MByte
- 156,000 saved values
- Recording range dependent on the user-defined measurement data memory configuration over a few months
- Recording freely configurable

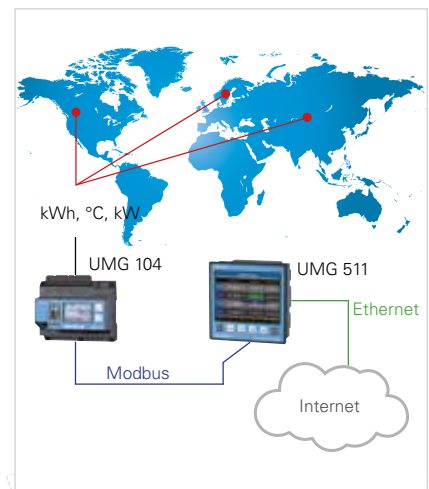

Fig.: Word-wide remote monitoring of the energy consumption and temperature for various different locations

Added value through additional functions

The UMG 104 goes far beyond the limits of digital multifunction measurement devices thanks to the integration of additional functions:

- Multifunction measurement device
- State monitoring
- Data logger
- Meters (kWh, kvarh)
- Temperature monitoring
- Harmonics analyser

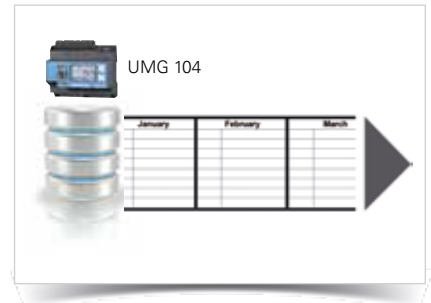

Fig.: Large measurement data memory

Due to the four current and voltage inputs there are also particular advantages with the monitoring of up to four single-phase outputs, e.g. in data centres, offices or single-phase motor outputs.

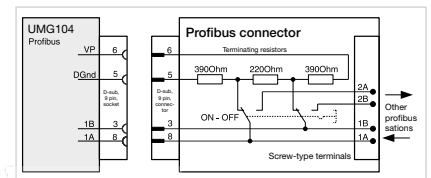

Fig.: Profibus connector, contact allocation

www.MATERIALEELETTRICE.IT
Consigliere specializzata



Dimension diagrams

All dimensions in mm

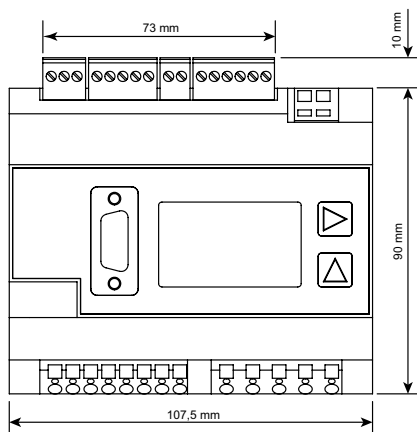

Front view

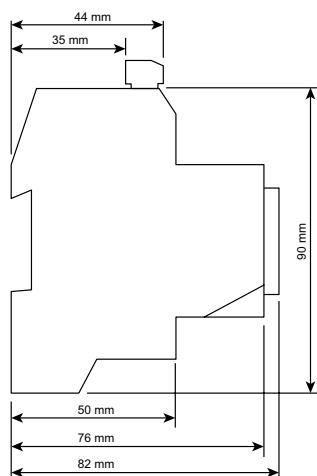

Side view



Typical connection

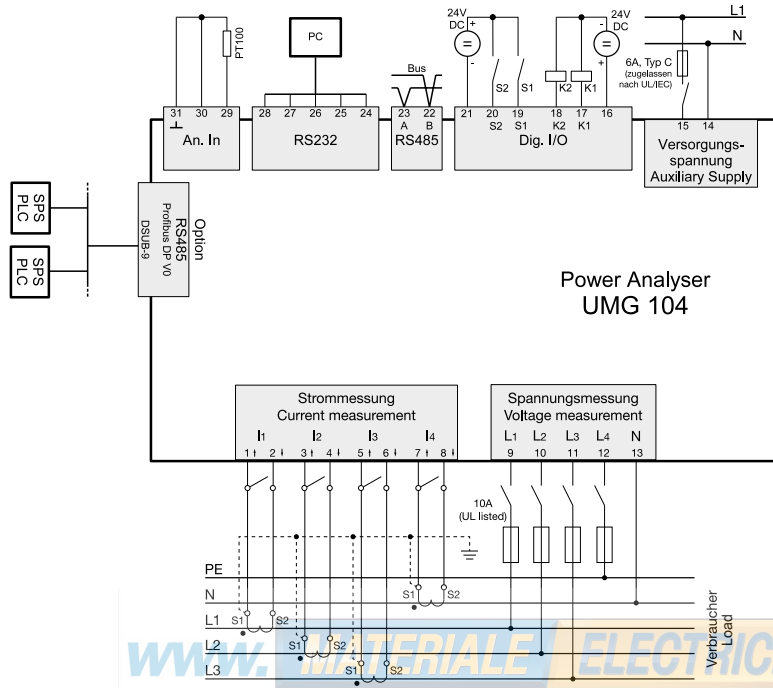

WWW.MATERIALELECTRONICE.ro
Consiliere specializata



Device overview and technical data

	UMG 104			UMG 104P
Item number		52.20.003		
Item number (UL)	52.20.201	-	52.20.205	52.20.202
AC supply voltage	95 to 240 V AC	50 to 110 V AC	20 to 50 V AC	95 to 240 V AC
Supply voltage DC	135 to 340 V DC	50 to 155 V DC	20 to 70 V DC	135 to 340 V DC
Communication				
Interfaces				
RS485: 9.6 – 921.6 kbps (screw-type terminal)	•	•	•	•
RS232: 9.6 – 115.2 kbps (screw-type terminal)	•	•	•	•
Profibus DP: Up to 12 Mbps (DSUB-9-socket)	-	-	-	•

An RS232 connecting cable is not included in the delivery and must be ordered separately as item no. 08.02.427.

General	
Net weight	350 g
Device dimensions	approx. l = 107.5 mm, w = 90 mm, h = 82 mm (per DIN 43871:1992)
Housing flammability rating	UL 94V-0
Installation position	any
Fastening/assembly	35 mm DIN rail (as per IEC/EN60999-1, DIN EN 50022)
Battery	Type VARTA CR2032, 3 V, Li-Mn
Service life of the backlight (optional)	40000 h (50% of the initial brightness)

Ambient conditions during operation	
The UMG104 is intended for weather-protected, stationary use. The UMG104 meets the operating conditions according to DIN IEC 60721-3-3.	
Working temperature range	-10° C to +55° C
Relative humidity	5 to 95% (at +25° C) without condensation
Operating altitude	0 to 2000 m above sea level
Pollution degree	2
Installation position	any
Ventilation	forced ventilation is not required.

Transport and storage	
The following information applies to devices which are transported or stored in the original packaging.	
Free fall	1 m
Temperature	-20° C to +70° C

Supply voltage	
The supply voltage must be connected to the UMG104 via a UL listed circuit breaker or G-fuse link. When using G-fuse links, the fuse holder must also be UL listed.	
Miniature circuit breaker	6 A, type C (approved i.a.w. UL/IEC)
G-fuse link, 5 x 20 mm	0.6 A trigger characteristic M (medium)
G-fuse link, 6.3 x 32 mm	0.75 A trigger characteristic F (fast)
230 V option: Nominal range Operating range Overvoltage category Power consumption	95 V to 240 V (50/60 Hz) or DC 135 V to 340 V ± 10% of nominal range 300 V CAT III max. 3.2 W, max. 9 VA
90 V option: Nominal range Operating range Overvoltage category Power consumption	50 V to 110 V (50/60 Hz) or DC 50 V to 155 V ± 10% of nominal range 300 V CAT II max. 3.2 W, max. 9 VA
24 V option: Nominal range Operating range Overvoltage category Power consumption	20 V to 50 V (50/60 Hz) or DC 20 V to 70 V ± 10% of nominal range 300 V CAT II max. 5 W, max. 8 VA

Connectable conductors	
Only one conductor can be connected per terminal!	
Single core, multi-core, fine-stranded	0.08 - 2.5 mm ² , AWG 28 - 12
Terminal pins, core end sheath	1.5 mm ² , AWG 16

Protection class	
Protection class II in accordance with IEC 60536 (VDE 0106, part 1), i.e. a ground wire connection is not required!	
Protection against ingress of solid foreign bodies and water	IP20 as per EN60529 September 2000, IEC60529:1989

Chapter 02

UMG 104

Digital inputs	
2 digital inputs	
Pulse input (S0): Maximum count frequency	20 Hz
Switching input: Response time Input signal present Input signal not present	200 ms 18 V to 28 V DC (typical 4 mA) 0 to 5 V DC, current less than 0.5 mA

Digital outputs	
2 digital outputs, semiconductor relays, not short-circuit proof.	
Switching voltage	max. 60 V DC, 30 V AC
Switching current	max. 50 mAeff AC/DC
Response time	200 ms
Output of voltage dips	20 ms
Output of voltage exceedance events	20 ms
Pulse output (work pulse)	max. 20 Hz

Connectable conductors	
Only one conductor can be connected per terminal!	
Single core, multi-core, fine-stranded	0.08 - 1.5 mm ²
Terminal pins, core end sheath	1 mm ²

Temperature measurement input	
Update time	Approx. 200 ms
Connectable sensors	PT100, PT1000, KTY83, KTY84
Total burden (sensor + cable)	max. 4 kOhm
Cable length	up to 30 m unshielded, from 30 m shielded

Sensor type	Temperature range	Resistance range	Measurement uncertainty
KTY83	-55° C to +175° C	500 Ohm to 2.6 kOhm	± 1.5% rng
KTY84	-40° C to +300° C	350 Ohm to 2.6 kOhm	± 1.5% rng
PT100	-99° C to +500° C	60 Ohm to 180 Ohm	± 1.5% rng
PT1000	-99° C to +500° C	600 Ohm to 1.8 kOhm	± 1.5% rng

rng = metering range

RS232 interface	
Connection	5-pin screw-type terminals
Protocol	Modbus RTU/slave
Transmission rate	9.6 kbps, 19.2 kbps, 38.4 kbps, 57.6 kbps, 115.2 kbps

RS485 interface	
Connection	2-pin screw-type terminals
Protocol	Modbus RTU/slave, Modbus RTU/master
Transmission rate	9.6 kbps, 19.2 kbps, 38.4 kbps, 57.6 kbps, 115.2 kbps, 921.6 kbps

RS485 interface (option)	
Connection	Plug, SUB D 9-pin
Protocol, Profibus (option)	Profibus DP/V0 per EN 50170
Transmission rate	9.6 kBaud to 12 MBaud

Measurement uncertainty	
Measurement uncertainty on the device applies when using the following metering ranges. The measured value must be within the specified limits. The measurement uncertainty is not specified outside of these limits.	
Measured value	Measurement uncertainties
Voltage	± 0.2% as per DIN EN 61557-12:2008
Current L	± 0.25% in accordance with DIN EN 61557-12:2008
Current N	± 1% as per DIN EN 61557-12:2008
Power	± 0.5% as per DIN EN 61557-12:2008
Harmonics U, I	Class 1, DIN EN 61000-4-7
Active energy	
Current transformer ..5 A	Class 0.5S (DIN EN62053-22:2003, IEC62053:22:2003)
Current transformer ../1 A	Class 1 (DIN EN62053-21:2003, IEC62053:21:2003)
Reactive energy	
Current transformer ..5 A	Class 2 (DIN EN62053-23:2003, IEC62053:23:2003)
Current transformer ../1 A	Class 2 (DIN EN62053-23:2003, IEC62053:23:2003)
Frequency	± 0.01 Hz
Internal clock	±1 minute/month (18° C to 28° C)

The specification applies under the following conditions:

- annual re-calibration,
- a warm-up time of 10 minutes,
- an ambient temperature of 18 to 28° C.

If the device is operated outside the range of 18 to 28 °C, an additional measuring error of ± 0.01% of the measured value per °C deviation must be taken into account.

www.MATERIALEELECTRICE.ro

Consiliere specializata

Voltage measurement inputs	
Three-phase 4-conductor systems (L-N/L-L)	max. 277 V / 480 V
Three-phase 3-conductor systems (L-L)	max. 480 V
Resolution	0.01 V
Metering range L-N	0 ¹⁾ to 600 600 V _{rms}
Metering range L-L	0 ¹⁾ to 1000 V _{rms}
Crest factor	2 (related to 480 V _{rms})
Overvoltage category	300 V CAT III
Measurement voltage surge	4 kV
Impedance	4 MOhm / phase
Power consumption	approx. 0.1 VA
Sampling rate	20 kHz / phase
Transients	> 50 µs
Frequency of the fundamental oscillation	45 Hz to 65 Hz

¹⁾The UMG device can only determine measured values, if an L-N voltage of greater than 10 Veff or an L-L voltage of greater than 18 Veff is applied to at least one voltage measurement input.

Terminal connection capacity (current measurement and voltage measurement)	
Connectable conductors. Only one conductor can be connected per terminal!	
Single core, multi-core, fine-stranded	0.08 - 4 mm ² , AWG 28 - 12
Terminal pins, core end sheath	2.5 mm ² , AWG 14

Current measurement	
Rated current	5 A
Rated current	6 A
Resolution on the display	10 mA
Metering range	0.001 to 8.5 A _{rms}
Crest factor	2 (related to 6 A _{rms})
Overvoltage category	300 V CAT III
Measurement voltage surge	4 kV
Power consumption	approx. 0.2 VA (Ri = 5 MOhm)
Overload for 1 sec.	100 A (sinusoidal)
Sampling rate	20 kHz

Firmware	
Firmware update	Update via GridVis®software. Firmware download (free of charge) from the website: http://www.janitza.com

Comment:
For detailed technical information, please refer to the operation manual and the Modbus address list.

