

## D6-40 red, D6-50 red, D6-63 red

Overvoltage protection for professionals

**Voltage relay ZUBR D6 red** (hereinafter referred to as the device) designed to protect domestic and industrial electrical equipment (including three-phase electric motors) and can operate in the following modes: a single-phase or a three-phase load.

During operation, the device measures and displays values of RMS voltage on each phase. All settings and trip values are stored in non-volatile memory. The device is powered from the measured phases and a neutral conductor.

### IN THE BOX

Voltage relay ZUBR D6 red	1 piece
Technical data sheet and installation and operation manual and warranty card	1 piece
The packing box	1 piece

### TECHNICAL DATA

Voltage limit	upper 220–280 V lower 120–210 V		
Break-time at increasing	not more than 0,04 sec		
Break-time at lower:	> 120 V	0,1–10 sec	
	< 120 V	not more than 0,04 sec	
Power Volt	not less than 100 V not more than 420 V		
The number of operating cycles under load of not less cycles	10 000 cycles		
The number of operating cycles without load of not less cycles	500 000 cycles		
Relay type	polarized		
A skew (asymmetry) phases	10–80 V		
Device weight	0,43 kg ±10 %		
Overall dimensions (w x h x d)	106 x 85 x 66 mm		
IP to GOST 14254	IP20		
Model	D6-40 red	D6-50 red	D6-63 red
Rated load current (for category AC-1)	3 x 40 A (max 3 x 50 A in 10 minutes)	3 x 50 A (max 3 x 60 A in 10 minutes)	3 x 63 A (max 3 x 80 A in 10 minutes)
Rated load power (for category AC-1)	3 x 8 800 VA	3 x 11 000 VA	3 x 13 900 VA

**IMPORTANT!** Before the installation and operation of the device, please read by the end of this document. This will help to avoid possible danger, mistakes and misunderstandings.

### CONNECTION SCHEMES

The phases and a neutral conductor for measurement and power supply are determined by an indicator and supplied to the device. The connecting wires of the load phases are connected to the corresponding terminals 5–7 (L1–L3), and the neutral conductor (N) to terminal 8.

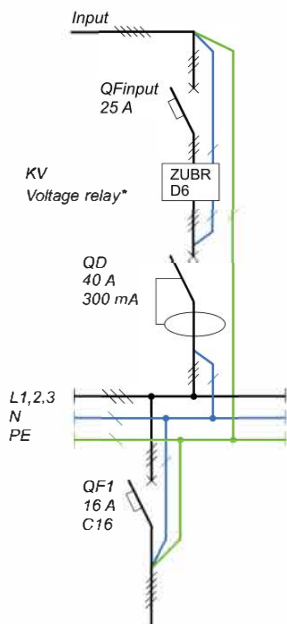

*\*For correct operation of ZUBR D6, it is enough to connect the neutral conductor to one of the zero terminals (4 or 8).*

Scheme 1. Option for connecting an RCD, a circuit breaker with zero transit through the device to a three-phase load.

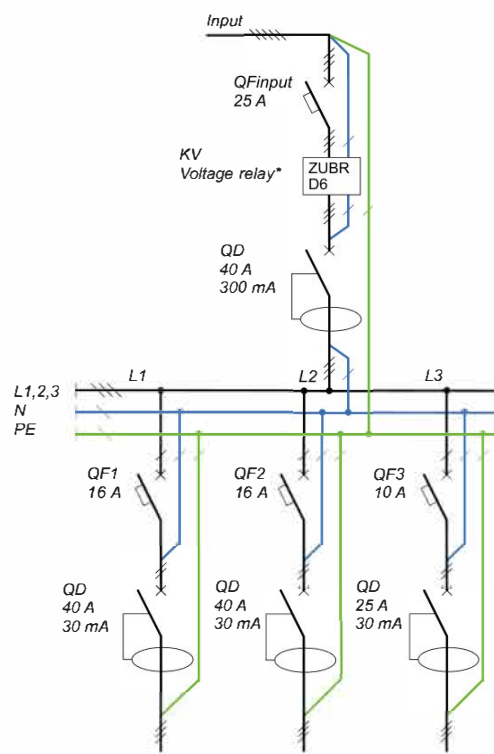

Scheme 2. Option for connecting an RCD, a circuit breaker with zero transit through the device to three single-phase loads.

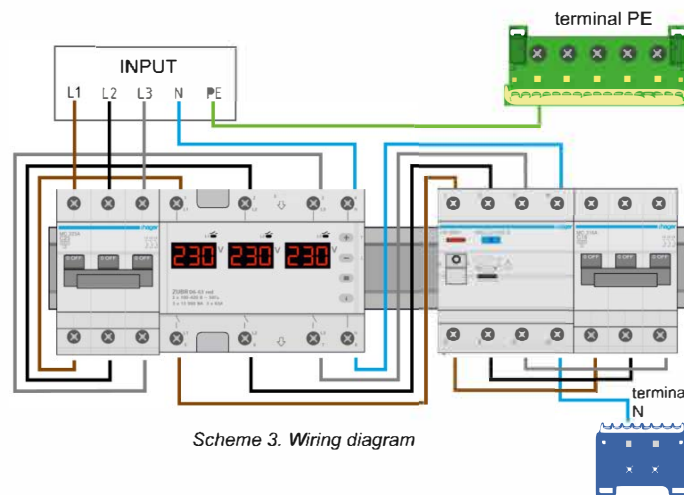

Scheme 3. Wiring diagram

### INSTALLATION

The appliance is intended for installation inside residences. The risk of moisture or humidity in the installation site should be minimal. The ambient temperature during the installation should be within  $-5...+45\text{ }^{\circ}\text{C}$ .

The appliance is installed in a special box, which allows to conduct the easy installation and operation. Cabinet should be equipped with standard mounting rail 35 mm width (DIN rail). The appliance takes in width of two standard module on 18 mm. The height of the appliance should be in the range 0,5...1,7 m from the floor.

For protection against short circuit and excess capacity in circuit load necessarily need to set in front of the appliance, the automatic circuit-breaker (QF). The automatic switch off is established in the open-phase fault wire, as shown at the schemes 1, 3. To protect person from electric shock leak is set safety shutdown device.

Terminals of the device designed for wire cross section 2 up to 16 mm<sup>2</sup>. It is advisable to use a soft wire, which is tightened in the terminals with a screwdriver with a tip width of no more than 6 mm with a torque of 2,4 N·m. A screwdriver with a blade more than 6 mm wide can cause mechanical damage to the terminals. Doing so will void your warranty claim.

### WARRANTY TERMS

The warranty for ZUBR devices is valid for 60 months from the date of sale, provided that the instructions are followed. The warranty period for products without a warranty certificate is counted from the date of production.

If your device is not working properly, we recommend that you first read the section «Possible problems». If you can not find an answer, contact Service Center. In most cases, these actions resolve all issues.

If you continue to have issues with the device, please send it to a Service Center or to the store where you purchased the device. If your device is defective due to our fault, we will repair or replace it under warranty within 14 business days.

If you have a warranty case, please, contact the General distributor in your area. Please see the full text of the warranty and the data you need to send to your Service Center on website <https://www.ds-electronics.com>



### WARRANTY CARD

serial №: \_\_\_\_\_ date of sale: \_\_\_\_\_

a seller, a seal \_\_\_\_\_ place of a seal \_\_\_\_\_

an owner contact for a service center: \_\_\_\_\_

### Choose the operating mode

To select a mode, hold down the «≡» button for 6 sec., use the «+» or «-» buttons to select a desired mode. When the mode is changed, the alarm log is automatically cleared.

**The single-phase load mode**  (asynchronous mode)

To select a mode, hold down the «≡» button for 6 sec., use the «+» or «-» buttons to select a desired mode. When the mode is changed, the alarm log is automatically cleared.

**The three-phase load mode**  (synchronous mode)

The device is capable of performing the functionality of three single-phase relays. The setting and control are separate for all power relays, while the device protects the equipment from voltage overshoot.

### Setting voltage limits

(factory setting 242 V / 198 V)

To view the upper limit, press the «+», button, to view the lower limit, press the «-» button. Then use the «+» and «-» buttons to change the limit as necessary.

**IMPORTANT.** When setting the voltage limits use the protected equipment technical documentation.

#### The single phase load mode:

First, use the «≡» button to select the desired phase.

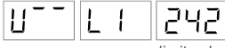
  
upper limit phase limit value №1

#### The three-phase load mode:

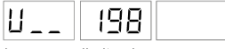
  
lower limit value for three phases

**Table 1. Two types of load switch-off speed: Model by default and Professional model**

Model	Limit	Voltage	Time
<b>Model by default</b>	Upper limit	220–280 V	0,04 sec
	Lower limit	120–210 V	0,1...10 sec
<b>Professional model</b>	Upper limit	< 120 V	0,04 sec
	Lower limit	> 264 V	0,04 sec
<b>Professional model</b>	PrO on	220–264 V	0,5 sec
		176–210 V	10 sec
		154–176 V	0,1...10 sec
		< 154 V	0,04 sec

### Alarm log in the single-phase load mode

To enter the log, press the «i» button. The screen will display the total number of alarms log entries. To navigate through the general log, use the «i», «+» or «-» buttons.

The log is able to store in the non-volatile memory the last 99 emergency alarms (n 1... n99, while «n 1» — last actuation, and «n99» — the oldest).

#### To view alarms in each phase separately

Press «i» to enter the Log. Then use «≡» to select the desired phase. Use the «i», «+» or «-» buttons to view the alarms of the selected phase.

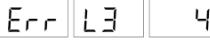
#### To reset Alarm log

Enter the Log and hold down «≡» for 3 seconds until «Err rSt» appears. After releasing the button, the log will be cleared.

The log will be automatically reset when switching between single-phase and three-phase load modes.

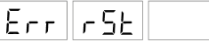
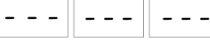
### Examples of alarms log entries

#### Upper limit alarm

  
entry phase №1 significance upper limit alarm

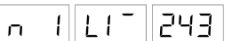
#### Lower limit alarm

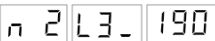
  
entry phase №3 significance lower limit alarm

#### An alarm due to break of the neutral conductor

  
entry break of the neutral conductor №4

#### An alarm as a result of incorrect relay status





  
entry error relay №5

#### Overheating alarm

  
entry overheat thermal protection response temperature №3

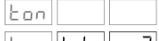
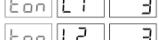
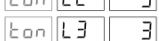
### Menu

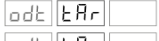
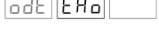
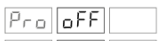
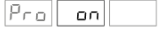
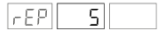
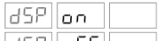
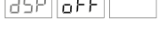
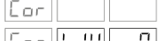
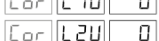
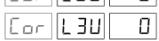
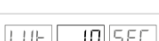
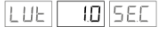
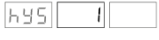
- To select a menu item, use «≡»
- Use the «+» and «-» buttons to change the parameters. After pressing the button for the first time, the parameter will flash, after pressing it for the second time the parameter will change. After 10 sec after pressing — return to the previous state or menu level.

MENU IN THE SINGLE-PHASE LOAD MODE	Press «≡»	Screen	Notes												
<b>Accident load switch-on delay</b> (factory setting 3 sec, a range of change 3–999 sec, step 3 sec)	1 time	   	During the countdown of the delay, the time until the voltage is switched on in seconds (t18.) Will flash on the corresponding display. Menu navigation: <ul style="list-style-type: none"> <li>To change the delay time, press «+» or «-».</li> <li>To select a phase, press «≡».</li> <li>To return to the menu, press «≡» three times.</li> </ul>												
<b>Type of Accident load switch-on delay</b> (factory setting «tAr»)	2 times	 	<b>«tAr»</b> time after voltage recovery — delay is counted from the moment of voltage recovery. <b>«tAo»</b> time after switching off - the delay (ton) is counted from the moment of switching off the device load and includes the time of accident action in the total delay time.												
<b>Professional load switch-off model</b> (factory setting «oFF»)	3 times	 	Professional model is not off load at safe in magnitude and duration of voltage deviations. More details of the model of the shutdown time when voltage goes beyond the limits are described in the Table. 1.												
<b>Maximum number of protection operations in sequence</b> (factory setting 5 operations, a range of change 1–5 operations, to disable this function, select «oFF»)	4 times		Protection against frequent actuations. Limits the number of repeated trips beyond the limit if no more than 20 sec have elapsed between turning on the load and activation of the protection. To disable the function, select «oFF».												
<b>ADVANCED SETTINGS</b> To enter hold for 3 seconds «≡»															
<b>Enable / disable the screen in the Standby mode</b> (factory setting «on», to exit the Standby mode, press one of the buttons)		 	Turns off the screen after 20 seconds after the last interaction with the device and in the absence of an emergency situation. In the event of an emergency situation on any of the phases, the corresponding screen will flash.												
<b>Correction of screen reading</b> (factory setting 0 V, range of change ±20 V)	1 time	   	You can use correction if voltage indications on the screen of the device and your reference device differ. <ul style="list-style-type: none"> <li>To change the delay time, press «+» or «-».</li> <li>To select a phase, press «≡».</li> <li>To return to the menu, press «≡» three times.</li> </ul>												
<b>Switch-off time in case of voltage failure</b> (factory setting 0,1 sec, a range of change 0,1–10 sec)	2 times		You can finely adjust the Voltage drop disconnection time. From the factory, this time will apply for the voltage range of 120-210 V. If you have activated the Professional model, then it applies for the range of 164-176 V. Refer to page 5 for details.												
<b>Hysteresis</b> (factory setting 1 V, a range of change 0–5 V)	3 times		It is necessary to reduce the number of the device operations by the limit, when the voltage in the network is close to the limit and is not stable.												
<table border="1" style="width: 100%; text-align: center;"> <tr> <td></td> <td>198</td> <td>199</td> <td>241</td> <td>242</td> <td>U, B</td> </tr> <tr> <td>Disconnect the device at the bottom limit.</td> <td>hYS = 1</td> <td>Voltage is satisfactorily, the device is on.</td> <td>hYS = 1</td> <td>Disable the device at high limit.</td> <td></td> </tr> </table>					198	199	241	242	U, B	Disconnect the device at the bottom limit.	hYS = 1	Voltage is satisfactorily, the device is on.	hYS = 1	Disable the device at high limit.	
	198	199	241	242	U, B										
Disconnect the device at the bottom limit.	hYS = 1	Voltage is satisfactorily, the device is on.	hYS = 1	Disable the device at high limit.											
<b>Neutral conductor failure control</b> (factory setting «oFF», setting range of permissible deviation between phase angles in percentage 10-35 %)	4 times		In a three-phase circuit, the phase angle is 120°, but in case of a neutral conductor failure, the phase angles are unbalanced. Set the permissible percentage of phase angle unbalance if you want to enable neutral conductor failure control.												

## Alarm log in the three-phase load mode

To enter the log, press the «i» button. The first 1.5 sec the screen will display the total number of alarms in the log, then the last trouble. Use «i», «+» or «-» to navigate through the log.

The log is able to store in the non-volatile memory the last 99 emergency alarms (n 1... n99, while «n 1» — last actuation, and «n99» — the oldest).

To reset the log enter the Log and hold down «E» for 3 seconds until «Err rSt» appears. After releasing the button, the log will be cleared.



The log will be automatically cleared when the Operating Mode is changed, for example, from single-phase to three-phase load. When you release the button, the log is cleared.

## Examples of alarms log entries

### Phase unbalance alarm

Initially, the screens display for 3 sec: the log entry number, the numbers of the phases between which the skew occurred, and the skew value. For the next 3 sec, the screens show the voltage values on the phases between which there was an skew.

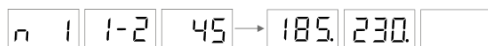

entry №1 № of phases between which there is a skew voltage skew

### Upper limit alarm



entry №1 alarm phase between the upper limit voltage alarm

### Lower limit alarm

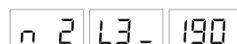

entry №2 alarm phase between the lower limit voltage alarm

### Accident due to violation of phase sequence

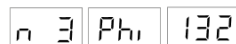

entry №3 sticking, phase sequence disturbance phases order during alarm

### An alarm due to overheating



entry №3 overheat during overheating temperatures

### An alarm due to break of the neutral conductor

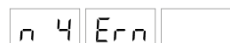

entry №4 break of the neutral conductor

### An alarm as a result of incorrect relay status

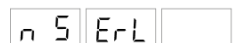

entry №5 relay error

MENU IN THE THREE-PHASE LOAD MODE	Press «E»	Screen	Notes
<b>Accident load switch-on delay</b> (factory setting 3 sec, a range of change 3–999 sec, step 3 sec)	1 time		During the countdown of the delay, the time until the voltage is switched on in seconds will flash on the corresponding display.
<b>Type of Accident load switch-on delay</b> (factory setting «tAr»)	2 times		«tAr» time after voltage recovery — delay is counted from the moment of voltage recovery «tAo» time after switching off - the delay (ton) is counted from the moment of switching off the device load and includes the time of accident action in the total delay time.
<b>Professional load switch-off model</b> (factory setting «oFF»)	3 times		Professional model is not off load at safe in magnitude and duration of voltage deviations. More details of the model of the shutdown time when voltage goes beyond the limits are described in the Table. 1.
<b>Maximum number of protection operation in sequence</b> (factory setting 5 operations, a range of change 1–5 operations, to disable this function, select «oFF»)	4 times		Protection against frequent actuations. Limits the number of repeated trips beyond the limit if no more than 20 seconds have elapsed between turning on the load and activation of the protection. To disable the function, select «oFF». Please note that the relay provides for automatic unlocking 1 hour after the «rEP» is triggered, this measure will ensure partial operation of your equipment until the network problem is resolved.
<b>ADVANCED SETTINGS</b> To enter hold for 3 seconds «E»			
<b>Phase unbalance voltage</b> (factory setting 20 V, a range of change 10–80 V, to disable, increase the skew value until «oFF» appears.)			This is permissible voltage difference between the two phases. If the load is switched off due to a violation of the phase unbalance voltage limit, will alternate on the screen: 
<b>The phase unbalance disconnection time</b> (factory setting 1 sec, a range of change 0–30 sec)	1 time		Available only when «Phase unbalance voltage» is on. Setting the protection reaction time to phase unbalance.
<b>Enable / disable the screen in the Standby mode</b> (factory setting «on», to exit the Standby mode press one of the buttons)	2 times 1 time, if «Phase unbalance voltage» is off		Turns off the screen after 20 sec after the last interaction with the device and in the absence of an emergency situation. In the event of an emergency situation on any of the phases, the corresponding screen will flash.
<b>Correction of screen reading</b> (factory setting 0 V, a range of change ±20 V)	3 times 2 time, if «Phase unbalance voltage» is off		You can use correction if voltage indications on the screen of the device and your reference device differ. <ul style="list-style-type: none"> <li>To change the delay time, press «+» or «-».</li> <li>To select a phase, press «E».</li> <li>To return to the menu, press «E» three times.</li> </ul>
<b>Switch-off time in case of voltage failure</b> (factory setting 0,1 sec, a range of change 0,1–10 sec)	4 times 3 time, if «Phase unbalance voltage» is off		It is necessary to fine-tune the response time of the protection to power failures. More details in the Table 1: the Pro mode is enabled: 164–176 V, the Pro mode off: 120–210 V.
<b>Hysteresis</b> (factory setting 1 V, a range of change 0–5 V)	5 time (4 times, if «Phase unbalance voltage» is off)		It is necessary to reduce the number of the device operations by the limit, when the voltage in the network is close to the limit and is not stable. 
<b>Neutral conductor failure control</b> (factory setting «oFF», setting range of permissible deviation between phase angles in percentage 10-35 %, step 5%)	6 time (5 times, if «Phase unbalance voltage» is off)		In a three-phase circuit, the phase angle is 120°, but in case of a neutral conductor failure, the phase angles are unbalanced. Set the permissible percentage of phase angle unbalance if you want to enable neutral conductor failure control.
<b>ADVANCED SETTINGS</b> To enter hold for 9 seconds «E»			
<b>Phase sequence</b> (factory setting «on»)			If the phase sequence is violated, the current phase sequence and the voltage across them will alternate on the screen. The phase sequence is always determined relative to phase L1.
<b>No-phase control</b> (factory setting «on») Possible when the Phase Unbalance Voltagemenu is Off	1 time		No-phase control is only possible when the Phase Unbalance Voltagemenu is off. When the function is disabled, the device will not disconnect the load if there is no voltage on the phase(s).

## Accident load switch-on delay

This is an adjustable time until the load switch-on after an emergency. The delay settings is described in Tables Menu.

When the type «tAr» is on: if the delay time is longer than 6 sec, then during a short-time voltage jump before the countdown, will be displayed an emergency situation and remaining time before the load activation on for 2 sec.

**For protection compressor equipment, such as a refrigerator or air conditioner, we recommend setting the delay duration of 120-180 sec. It will allow to increase the service life of the compressor.**

## Locking the controls

To lock (unlock), hold down the «+» and «-» buttons for more than 6 seconds until the message «Loc» («unLoc») appears on the screen.

## Viewing of calculated linear stresses

Hold the button «i» for 3 sec. At the corresponding screens, the phase numbers will appear, between which linear voltages are calculated.

When releasing the screens for 30 sec calculated linear voltages will be displayed with an accuracy of 2-3 V.

1-2 2-3 1-3 → 400 399 399

## Viewing of firmware version

Hold the button «i» for 6 sec. The manufacturer reserves the right to modify the firmware to enhance the device technical characteristics.

## Reset to factory settings

To reset the factory settings, hold the three buttons «+», «-» and «≡» at the same time for more than 12 sec. until «dEF» message appears on the screen. After release, reset to factory settings and reboot will take place, th alarm log is cleared.

dEF

## A tripping counter

To view hold the button «i» for 12 sec. Do not discharged.

r0F 100

## Viewing temperature of the internal overheating sensor

Hold the button «i» for 18 sec.

int 25 °C

## POSSIBLE PROBLEMS, CAUSES AND WAYS TO OVERCOME THEM

### At turning on neither indicator nor screendo not shine

*Possible cause:* There is no power supply voltage.

*It is necessary to:* Ensure supply voltage presence.

### After turning on on the screen normal voltage level, but load is not turning on

*Possible cause:* the current voltage in the network is close to the established limits and not stable.

*It is necessary to:* check the values of the limits; increase their values so that the protected equipment is tolerated to them. In other cases, please, address to a service centre.

### The load is disabled, «oht» flashes on the screen

The temperature inside the housing exceeded 70 °C and triggered protection against internal overheating.

oht 71 °C

When the temperature drops below 60°C, the unit will resume operation.

oht 52 °C

If the protection trips more than 5 times within 24 hours, the voltage relay is blocked until the temperature inside the case drops to 52 °C and one of the buttons is pressed.

*Possible cause:* inner overheating of the device to which can lead: bad contact in the terminals of the device, high ambient temperature, overwhelming power output or incorrectly selected cross-section of wires for connecting.

*It is necessary to:* check tension of power wires in the device terminals, make sure that the switching load does not exceed the permissible and that the cross section of the wires is selected correctly.

### Every 5 seconds, th screen displays «Ert»

Ert

*Possible cause:* open or short circuit of the internal overheating sensor. Control over inner overheating will not be done.

*It is necessary to:* Send the device to the Service Center. Otherwise, control over inner overheating will not be done.

### Every 10 seconds on the screen «Erb», the device does not respond to button presses

Erb

*Possible cause:* the device detects button presses longer than 2 minutes.

*It is necessary to:* restart the device by switching off and on the power supply. Ensure that the buttons are not stuck during operation; otherwise, contact the Service Center.

### Every 5 seconds the screen displays «Ern»

Ern

*Possible cause:* The device detected a neutral wire break.  
*It is necessary to:* check the three-phase network on your own or consult a relevant expert, adjust the device settings according to the specifics of your network.

### The load is disabled, the screen displays «rPF»

rPF The relay was locked to draw attention to the dangerous situation and protect the equipment.

*Cause:* The maximum number of frequent operations in case of unstable network has been exceeded.

It is necessary to: unlock the relay by pressing any button, then press «i» to find out the cause of tripping in the Alarm log. Take steps to correct the problem, if possible. Note that the relay will unlock automatically 1 hour after the «rEP» is triggered, this measure will keep your equipment partially operational until the network problem is corrected.

### Frequent load trip

*Possible cause:*

- underestimated (overestimated) value of the upper (lower) limit;
- low hysteresis value set.

*It is necessary to:*

- increase the value of the limits so that the protected equipment is tolerant of their values;
- increase the hysteresis value.

### «ErL» (Error relay) flashes on the screen of one of the phases

ErL

*Possible cause:* The state of the power relay on one of the phases does not correspond to the operating logic.

According to the device's logic, it constantly monitors the status of three power relays. If the relay is functioning normally on the respective phase, the green LED will be lit.

If the state of the power relay deviates from the operating logic, the device will attempt to:

- In single-phase load mode, change the state of the power relay.
- In three-phase load mode, disconnect all power relays.

If the device fails to determine the relay's state, it will periodically attempt to disconnect it. In this case, the green LED will blink on the respective phase.

*It is necessary to:* Clear the «ErL» error by restarting the device. To do this, turn off and then turn on the power. If the error persists, contact the Service Center.

## SAFETY INSTRUCTIONS

Carefully read and become aware of yourself these instructions.

Connection of the device must be done by a qualified electrician.

Before the installation (dismantling) and connection (disconnection) of the device, turn off voltage supply and also act according to the «Rules of an arrangement of electric installations».

Turning on and off or and configure the device should be with dry hands.

Do not connect the device to the network disassembled.

Avoid hitting of water or moisture to the device.

Do not expose the device to extreme temperatures (higher than 40 °C or below -5 °C) and high humidity.

Never clean the device with the use of chemicals such as benzene, solvents.

Do not store the device and do not use it in areas with the dust.

Do not attempt to disassemble and repair the device.

Do not exceed the landmarks value adaptor and power.

To protect against overvoltage caused by lightning discharges, use a lightning protector.

Protect the children from games with the working device, it is dangerous.

## ADDITIONAL INFORMATION

Do not fire and do not throw away the device with the household waste.

After the end of its service life, the product must be disposed of in accordance with applicable law.

Transportation of goods carried in the package, ensuring the safety of the product.

The deive is transported by any kind of transport (rail, sea, motor, air transportation).

Date of manufacture is on the back side of device. Application time is unlimited.

The device does not contain harmful substances.

If you have any questions or you something will not clear, call the Service centre the telephone number listed below.

vd6.76.3.2\_230811



EMC Directive 2014/30/EU  
Low Voltage Directive 2014/35/EU