

## ■ DATASHEET: INDUSTRIAL ENCLOSURE FOR CONTROL- AND COMPUTERSYSTEMS 19" IP54 DSP376065



### ■ APPLICATION

Enclosure for Input-Devices and Display of Control-Units or Computer with Keyboard, Mouse and Monitor. To be used in production halls or similar environments. Special construction for rough, dusty environments, if installed equipment is worth to be especially protected and/or equipment needs special protection due to environmental conditions (dust, humidity). The installed equipment is often the central station for the production machinery. Best availability of the (production-) machinery is achieved due to the special protection of the installed equipment against dust and humidity (Protection IP54). Machinery down-time due to defect of central station because of dust or humidity is avoided. The lockable departments of the enclosure provide protection against unauthorized access.

## ■ TECHNICAL DATA

- Steel sheet
- Dimensions: Height: 1.750 mm, Width: 600 mm, Depth: 600 mm
- Color: Doors, Side- and Backpanel: light grey RAL 7035, Frame: blue RAL 5005
- Max. Load: 400 kg
- IP Rating: IP 54
  - All doors, rear- and sidepanels are sealed, which ensures protection against dust and humidity.
  - Enclosure is without perforation.
- Ventilation: Cooled by sharing heat with environment via chassis..
- Rear- and sidepanels: Fixed to frame by screws. Demountable.
- Cable Entry: 300x100 mm at the bottom. Covered by a sealed and screwed blanking panel. Method of cable leading inside the enclosure must correspond to requested IP protection level against dust and humidity.
- Earthing:
  - M8-Earthing point plus 19"-Earthingset.
  - FastOn-Earthingconnections to all dismountable parts pre-installed.
- Departments: 3
  - Separation of upper and lower departments by pre-installed 350 mm deep sliding shelf for keyboard and mouse.
  - Cable-guiding in rear part of the enclosure.
  - Vertical cable-management can be flexibly organized by use of optional cable-organizers DBKO8080.
- Bottom department:
  - Used for control-unit or computer.
  - 21U / 934 mm
  - Fullmetal door RAL 7035. Swinghandle with halfcylinder. Same key as other locks. Halfcylinder can be changed. Door can be opened 180°. Hinged right.
  - Two pairs of vertical 19"-rails. 21U. Continuously depth-adjustable.
- Middle department:
  - Used for input-device or keyboard and mouse.
  - 4U / 178 mm
  - Fullmetal door RAL7035, folding, single point lock. Same key as other locks.
  - Sliding shelf W=460 mm, D=350 mm for keyboard and mouse pre-installed. Usable depth if fully drawn out: 240 mm.
  - Mouse-shelf W=150 mm, D=170 mm can be drawn out under right side of keyboard shelf.
  - Keyboard and mouse not included in delivery.
- Top department:
  - Used for display-device or computer monitor.
  - 12U / 534 mm
  - Glasdoor, 4 mm safety glass, RAL 7035. Swinghandle with halfcylinder. Same key as other locks. Halfcylinder can be changed. Door can be opened 180°. Hinged right.
  - Two pairs of vertical 19"-rails. 12U. Continuously depth-adjustable.
  - Optional a fixed shelf with 350 mm (DFS14835-C), 450 mm (DFS14845-C) or 550 mm (DFS14855-C) depth can be installed to put display devices or computer monitors on it.
- Distances (valid for bottom and top department):
  - Space between front vertical 19"-rail and door glass at max. spacing: 35 mm
  - Space between rear vertical 19"-rail and rear panel at max. spacing: 35 mm
  - Maximum distance between vertical rails (19"-rails): 510 mm
  - Max Maximum usable depth in free-standing cabinets when installed e.g. on shelves: 575 mm
  - Spacing between vertical 19"-rails: 451 mm
- Including assembly materials: 16x Cage nuts, bolts and washers M6.
- Wide range of available accessories (fixed and sliding shelves, patch panels, cable management, PDUs, light-unit, etc.).
- Enclosure is delivered fully-assembled on a disposable pallet.

## DIMENSIONS

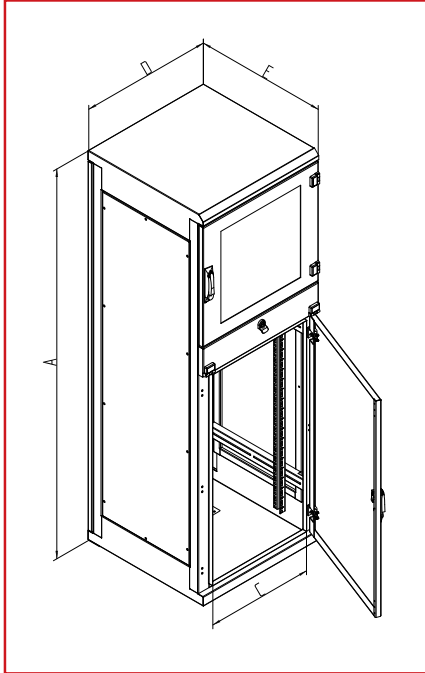

A	C	D	E	GROSS - WEIGHT (kg)	NET- WEIGHT (kg)	MAX. LOAD (kg)	IP RATING
1750	487	600	600	92	85	400	IP 54

DESCRIPTION	ORDER NO.
Industrial enclosure for control- or computersystems, 19", IP54	DSP376065

### ACCESSORIES

Fixed shelf 350mm, RAL7035, Load up to 50kg	DFS14835-C
Fixed shelf 450mm, RAL7035, Load up to 80kg	DFS14845-C
Fixed shelf 550mm, RAL7035, Load up to 80kg	DFS14855-C
Fixed shelf 450mm, RAL7035, Heavy Duty. Load up to 150kg	DFSS4845-A
Fixed shelf 550mm, RAL7035, Heavy Duty. Load up to 150kg	DFSS4855-A
19" Power Distribution Unit, 7x Schuko, Overvoltage protection	IU070113
19" Light unit for 19"-installation with magnet	DV900330-A
19" DIN-rail panel 3U	DAB34810
Cable-Organiser for vertical cable management. Fixed to 19"-rail, 80x80mm	DBKO8080
Pouch for circuit diagrams, self adhesive, A4	ASDRA400