

Industrial LED lighting fixture made of die-cast EN AB 46100 aluminum with polyester powder coating. Correct lighting is provided by an optical system composed of different versions of lenses. Silicone gaskets, breathing and anti-condensation device in Goretex, waterproof connectors for 1.5 mm² cables and stainless steel external screws. Suspension fixing system with steel cables. The die-cast aluminum structure guarantees optimal performance conditions both @ Ta25 ° and @ Ta50 ° thanks to specific thermal sizing tests. The correct heat dispersion inside ESALITE is guaranteed by the special passive heat sink with a very low copper content that offers high qualitative and quantitative performances. Permanent emergency version with 3h autonomy and high temperature NiMH batteries. Signalling LED for charge status.

Versiuni	4000K lumină naturală	Greutate (Kg)	4.5
Optică	90°	Puterea sistemului	60 W
Lumină ieșire (lm)	6700	Temperatură de culoare	4000 K (CRI>80)
Flux nominal (lm)	7200	Aplicație	Internă
Cod IK	IK06	Temperatură de operare	0 + +40 °C
Culoare	Gri RAL 9006 + 7035	Lampa tip	LED - Neînlocuibil
Tip driver	Driver Dali	Curent LED	0.6 A
Seria	ESALITE HB - 6K	Clasă de protecție IP	IP55
Clasă izolație	I	Tensiune	220/240 V - 50/60 Hz
Clasă de eficiență a LED-urilor integrate	A + A++	Garanție	5 ani
Life time L90B10 (Tq 25°)	100000 h	Life time L90B10 (Tq 50°)	55000 h
Ieșire lumen (lm)	6700	Ecran	Plastic
Tip	Urgență	Flux luminos de urgență	650
Autonomie	3 h	Glow Test conductori	650 °C
Versiune	Urgență	Tip sursă de lumină	LED - Neînlocuibil
Dispozitiv cu temperatură la suprafață redusă	Conform	Certificare DIN 18032-3	Nu
Curent LED	0,6A	Electrocod	2444

DIMENSIONAL

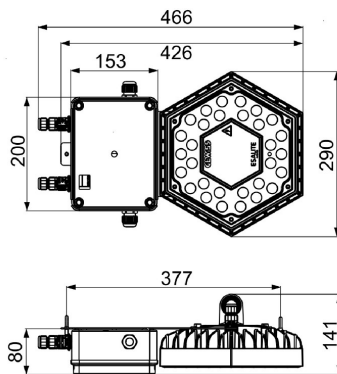

PHOTOMETRIC DISTRIBUTION

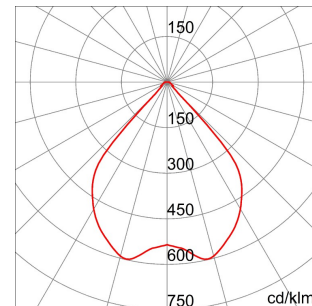

TECHNICAL SYMBOLOGY



IK

IK06

IP

IP55



GWT

650 °C



STANDARDS/APPROVALS



Data, measures, designs and pictures are shown only as informativ purposes, and could be changed without previous notice - Last update 09/11/2019