



## Cable connecting systems & Accessories **Low and Medium Voltage**

# PRODUCT CATALOGUE

Systems For Professionals

**CELLPACK**  
Electrical Products

## Information

Our customer service and sales specialists are at your disposal for any further technical or commercial questions you may have.

You can find further information on our products in our online Product catalogue under [electricalproducts.cellpack.com](http://electricalproducts.cellpack.com)

Our general trading conditions are available on our website [www.cellpack.com](http://www.cellpack.com)



All data, values, pictures and illustrations printed in this documentation, are correct and reliable, according to the current state of our knowledge. The intention is to represent our standard product range, and should not be considered as a guarantee for specific characteristics (such guarantees are given in our manufacturing standards). The user of these products is responsible for determining their suitability for a given application. Our liability for these products is limited according to the terms outlined in our general trading conditions.

**This Product catalogue replaces all previous versions. Changes, in the sense of technical progress and misprints, reserved.**

<b>LOW VOLTAGE</b>	<b>9</b>
Heat shrink technology . . . . .	11
Cast resin technology . . . . .	75
Gel technology . . . . .	115
<b>MEDIUM VOLTAGE</b>	<b>121</b>
Cable sets for unscreened polymeric cables . . . . .	123
Cable sets for screened polymeric cables . . . . .	129
Cable sets for mass-impregnated paper cables . . . . .	171
Heat shrinkable components . . . . .	191
<b>CONNECTING TECHNOLOGY</b>	<b>197</b>
Compression connectors . . . . .	198
Compression cable lugs . . . . .	204
Screw connectors . . . . .	207
Screw cable lugs . . . . .	208
Branch ring connectors . . . . .	209
Miscellaneous . . . . .	211
<b>ELECTRICAL INSULATION AND MOUNTING TAPES</b>	<b>221</b>
Electrical insulation and mounting tapes . . . . .	223
Additional tapes . . . . .	240
Miscellaneous . . . . .	244
<b>ACCESSORIES</b>	<b>245</b>
Heating systems . . . . .	246
Cable ties . . . . .	248
Tools . . . . .	251
Chemical products . . . . .	258
Miscellaneous . . . . .	273
<b>INDEX</b>	<b>281</b>
Index: of article numbers . . . . .	282
Index: of article designations . . . . .	289
Index: of product families . . . . .	290

# COMPANY PROFILE

## Electrical Products



Being an SME company within the Behr Bircher Cellpack (BBC) Group in Villmergen/ Switzerland, Cellpack Electrical Products has successfully established itself in the global markets, in the fields of development, production and customer oriented sales of cable connecting systems and accessories for the low and medium voltage up to 42 kV.

## Systems For Professionals



Power utilities, electrical wholesalers, specialist electrical trade or the industry – they all share one thing in common: regarding a high operational safety for the power supply services in the distribution network as their first priority. The system solutions and products developed by Cellpack for complex, high-tech applications have significantly contributed to this.

## Technology & Innovation



With our customer-oriented understanding of technologies and the distinctive culture of innovation, we have committed ourselves to concentrate, not only on the demands of our customers for technically innovative and thoroughly tested products, but also to ensure the safe and reliable functioning of our system solutions.

## Quality & Service



Cellpack has gained worldwide recognition for highest material and product quality with standards being continuously controlled in our high-performance laboratories and testing facilities in Germany. This high benchmark also applies to the availability and delivery service of our products. The quality standard "Swiss Quality – Made in Germany" is our commitment.

# TECHNOLOGY AND PRODUCT PORTFOLIO

## Heat shrink technology



Cable accessories with heat shrink components made of extruded plastic material (thermoplaste) offer a wide field of applications for all kind of cables, as well as conductor and cross section range in the low and medium voltage. They protect the cable connection against water and moisture penetration and thus against metal corrosion and guarantee for excellent electrical insulation values as well as mechanical protection. The hybrid joints and terminations, designed by Cellpack especially for the medium voltage, combine components of silicone rubber and heat shrink products for safe and reliable operations.

The heat shrink product range includes straight-through, transition and pot end joints, terminations, wall ducts, repair sleeves and repair kits etc., heat shrink moulded parts as well as heat shrink tubes in various designs and types.

## Cast resin technology



The Cellpack cast resin joints offer an overall long-term protection in terms of insulation values and resistance for all kind of cable accessories and cross sections. This is guaranteed by high-grade, unfilled two-component PUR cast resins which are designed for various applications as well as by the shockproof plastic moulds available with or without integrated strain relief. After the hardening process, the cable joints are resistant to mechanical and electrical loads.

The scope of delivery for all cast resins straight-through and branch joints or universal connection and branch boxes of Cellpack includes a cast resin tailored to the pre-selected field of application. The cast resins are further available individually in two-chamber bags with separation bars, if requested. The mixing of the cast resin component and the hardener is effected directly before the filling into the mould which is designed with at least one filling opening.

## Gel technology



The EASYCELL® gel joints provide easy, fast and thus practical solutions for the connecting and branching of low voltage cables up to 1 kV. Hereby, the generously dimensioned plastic moulds with the added, permanently soft-elastic sealing material, together with the precisely positionable connection and branch-off blocks, guarantee for a safe electrical connection. As EASYCELL® will protect, insulate and seal instantly with the closing, the connection is ready for immediate operation after being installed.

A transparent two-component gel for easy and individually dosable cast of branch-off- and connection sockets rounds up the gel assortment. The Cellpack Power Gel provides a reliable sealing and protection of all electrical and electronic components and furthermore is removable.

## Plug-in technologies & Contrax technology



### Plug-in technologies

The compact, pluggable straight-through joint Compax with its particularly high level of pre-configuration, together with the innovative, pluggable connections Cellplux for outer-cone-systems, have been developed specifically for polymeric-insulated 1-core medium voltage cables. The integrated components system and robust construction also allow a fast and safe realization of cross-section range taking joint- or connector solutions.

### Contrax technology

The Contrax medium voltage terminations and straight-through joints provide the integration of the relevant core components within a one-piece insulator made of silicone rubber resistant to high voltage. These expand and are easily installed by means of the patented slip-on accessory with the assembly only.

All three Cellpack technologies guarantee for highest assembly and operational safety – not least by thorough quality controls and testing.

## Connecting technology



Cellpack screw connectors and screw cable lugs are suitable for cross-section ranges, reliable termination and joints of both, copper and aluminium cables. Furthermore, the innovative shear-off head bolts are designed for the use of just one conventional tool. The integrated centering and further technical optimizations allow to eliminate common assembly errors already before the installation.

Compression connectors, compression cable lugs, branch clamps and wire connectors in various types round up the connector portfolio tailored to the Cellpack cable sets for a safe and permanent connection of copper or aluminium cables.

## Electrical insulation and mounting tapes



Insulating, bundling, labeling, protecting, affixing, mounting, padding, sealing or repairing: Electrical insulation and mounting tapes for low and medium voltage have to meet most different requirements. Therefore, Cellpack has aligned the individual functional profiles of its tapes to the various applications in an optimal way.

The high-quality Premio PVC electrical insulation tapes, available in all standard colors, are particularly flexible, stabilized against UV rays and packed separately in practical plastic boxes. Furthermore, the Premio family provides PVC and PSE tapes for bundling and affixing, heat-resistant glass fibre cloth tapes as well as copper foil for discharge and screening.

Standard PVC insulation tapes, self-amalgamating tapes, cloth and sealing tapes as well as hot melt adhesives round up the assortment.











# LOW VOLTAGE

Heat shrink technology . . . . .	11
Cast resin technology . . . . .	75
Gel technology . . . . .	115



## Heat shrink technology

	Straight-through joints.....	12
	Transition joints.....	28
	Pot end joints.....	30
	Cable terminations.....	33
	Wall ducts.....	42
	Heat shrinkable tubes.....	43
	Moulded parts.....	69



## SMHSV

### Heat shrinkable straight-through joint

with screw connectors (with shear head bolts), for unarmoured polymeric cables and conductors

Universally suitable for connecting polymeric cables or conductors insulated with PVC, PE and XLPE (e.g. N(A)YY, NYM, TT). With mechanical connectors with shear head bolts, suitable for aluminium or copper cables.

#### Characteristics

- Compact dimensions
- Wide conductor and cross-section range
- Resistant to chemical agents
- Resistant to alkaline earth elements
- Stabilized against UV rays
- Free from paint-wetting inhibiting substances
- Halogen-free
- Transversely waterproof
- High electrical insulating values
- High mechanical strength

#### Application/Suitability

- Indoor
- Outdoor
- Underground
- Water
- Installation ducts
- Ductwork

#### Voltage level

- $U_0/U_m$  (U<sub>m</sub>) 0.6/1 (1.2) kV

#### Test standards

- DIN EN 50393 (corresponds to VDE 0278)

#### Storage conditions/Shelf life

- Unlimited shelf life

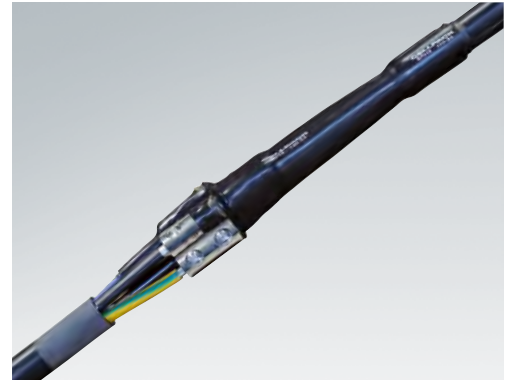

Dimensions

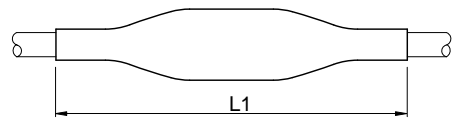

#### Scope of delivery

Outer sleeve, inner sleeves, screw connectors CSV-T with shear head bolts, cleaning tissue, emery cloth, assembly instructions

		Polymeric cable unarmoured			
		 4x			
Type	L1 mm	Nominal cross section per conductor mm <sup>2</sup>		Art.-No.	
SMHSV4	6-50	500	6 - 50		294806
	16-95	650	16 - 95		262697
	50-150	800	50 - 150		262699
	95-240	1000	95 - 240		262710

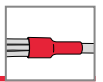

## SMH...V

### Heat shrinkable straight-through joint

with screw connectors, for unarmoured polymeric cables and conductors

Universally suitable for connecting polymeric cables or conductors insulated with PVC, PE and XLPE (e.g. N(A)YY, NYM, TT). With screw connectors with grub screw, suitable for aluminium and copper conductors.

#### Characteristics

- Compact dimensions
- Wide conductor and cross-section range
- Resistant to chemical agents
- Resistant to alkaline earth elements
- Stabilized against UV rays
- Free from paint-wetting inhibiting substances
- Halogen-free
- Transversely waterproof
- High electrical insulating values
- High mechanical strength

#### Application/Suitability

- Indoor
- Outdoor
- Underground
- Water
- Installation ducts
- Ductwork

#### Voltage level

- $U_0/U_m$  (U<sub>m</sub>) 0.6/1 (1.2) kV

#### Test standards

- DIN EN 50393 (corresponds to VDE 0278)

#### Storage conditions/Shelf life

- Unlimited shelf life



Dimensions

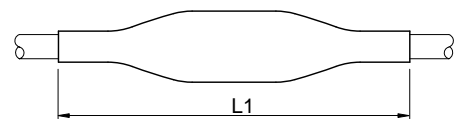

#### Scope of delivery

Outer sleeve, inner sleeves, screw connectors, allen key, cleaning tissue, emery cloth, assembly instructions

		Polymeric cable unarmoured			
		4x		5x	
Type		L1 mm	Nominal cross section per conductor mm <sup>2</sup>		Art.-No.
SMH5	1.5-6 V	250	1.5 - 6	1.5 - 6	145362
	6-35 V	500	6 - 35	6 - 35	145363



# SMH Heat shrinkable straight-through joint

for unarmoured polymeric cables and conductors

Universally suitable for connecting polymeric cables or conductors insulated with PVC, PE and XLPE (e.g. N(A)YY, NYM, TT). Suitable for compression connectors on aluminium or copper cables.

### Characteristics

- Compact dimensions
- Wide conductor and cross-section range
- Resistant to chemical agents
- Resistant to alkaline earth elements
- Stabilized against UV rays
- Free from paint-wetting inhibiting substances
- Halogen-free
- Transversely waterproof
- High electrical insulating values
- High mechanical strength

### Application/Suitability

- Indoor
- Outdoor
- Underground
- Water
- Installation ducts
- Ductwork

### Voltage level

- $U_0/U_m$  (U<sub>m</sub>) 0.6/1 (1.2) kV

### Test standards

- DIN EN 50393 (corresponds to VDE 0278)

### Storage conditions/Shelf life

- Unlimited shelf life

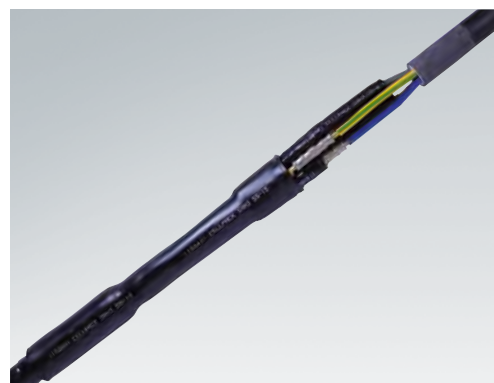

Dimensions

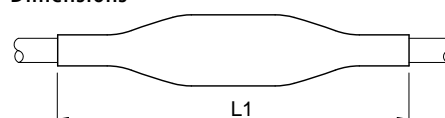

### Scope of delivery

Outer sleeve, inner sleeves, cleaning tissue, emery cloth, assembly instructions

Optional accessory: Compression connectors (see Connecting technology)

Type	L1 mm	Polymeric cable unarmoured				Art.-No.
		1x	3x	4x	5x	
		Nominal cross section per conductor mm <sup>2</sup>				
SMH1	10-25	300	10 - 25			150154
	35-70	400	35 - 70			150158
	95-240	500	95 - 240			150160
	150-300	500	150 - 300			150161
	300-500	600	300 - 500			150162
SMH3	1.5-16	400		1.5 - 16		151500
	6-25	500		6 - 25		145266
	25-70	700		25 - 70		145267
	95-150	850		95 - 150		145270
	185-300	1100		185 - 300		145273
SMH4	1.5-6	200		1.5 - 6		145246
	1.5-16	400		1.5 - 16		145249
	6-25	500		6 - 25		145296
	16-50	600		16 - 50		145320
	25-95	600		25 - 95		145332
	25-150	700		25 - 150		145282
SMH5	95-300	1000		95 - 300		145342
	1.5-6	250			1.5 - 6	145255
	1.5-10	250			1.5 - 10	145257
	1.5-16	400			1.5 - 16	145338
	16-25	500			16 - 25	145295
	35-95	500			35 - 95	126745
	120-240	800			120 - 240	126665

Note: Heat shrinkable connecting joints for shipyard application. Approvals by Lloyd's Register, Germanischer Lloyd and Bureau Veritas on request.

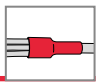

## SMH

### Heat shrinkable straight-through joint

with heat shrinkable crimp connectors, for control cables and signal cables

Universally suitable for connecting control cables and signal cables. With heat shrinkable crimp connectors on copper conductors.

#### Characteristics

- Compact dimensions
- Resistant to chemical agents
- Resistant to alkaline earth elements
- Stabilized against UV rays
- Free from paint-wetting inhibiting substances
- Halogen-free
- Transversely waterproof
- High electrical insulating values
- High mechanical strength

#### Application/Suitability

- Indoor
- Outdoor
- Underground
- Water
- Installation ducts
- Ductwork

#### Voltage level

- $U_0/U_m$  (U<sub>m</sub>) 0.6/1 (1.2) kV

#### Test standards

- DIN EN 50393 (corresponds to VDE 0278)

#### Storage conditions/Shelf life

- Unlimited shelf life



Dimensions

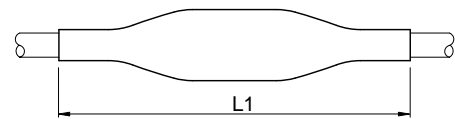

#### Scope of delivery

Outer sleeve, inner sleeves, heat shrinkable crimp connectors, cleaning tissue, emery cloth, assembly instructions

Control and signal cable					
Type	L1 mm	Number of conductors	Nominal cross section per conductor mm <sup>2</sup>	Art.-No.	
SMH	7/10 1.5-2.5	330	7 - 10	1.5 - 2.5	145486
	12/14 1.5-2.5	500	12 - 14	1.5 - 2.5	145489
	18/24 1.5-2.5	500	18 - 24	1.5 - 2.5	145493
	30/30 1.5-2.5	600	30 - 30	1.5 - 2.5	145496
	34/40 1.5-2.5	600	34 - 40	1.5 - 2.5	145541

Note: Heat shrinkable connecting joints for shipyard application. Approvals by Lloyd's Register, Germanischer Lloyd and Bureau Veritas on request.



## SMHA4

### Heat shrinkable straight-through joint

for tape and wire armoured polymeric cables

Universally suitable for connecting armoured polymeric cables insulated with PVC, PE and XLPE (e.g. N(A)YY, NYM, TT). Suitable for compression connectors on aluminium and copper conductors.

#### Characteristics

- Compact dimensions
- Wide conductor and cross-section range
- Resistant to chemical agents
- Resistant to alkaline earth elements
- Stabilized against UV rays
- Free from paint-wetting inhibiting substances
- Halogen-free
- Transversely waterproof
- High electrical insulating values
- High mechanical strength

#### Application/Suitability

- Indoor
- Outdoor
- Underground
- Water
- Installation ducts
- Ductwork

#### Voltage level

- $U_o/U_m$  0.6/1 (1.2) kV

#### Test standards

- DIN EN 50393 (corresponds to VDE 0278)

#### Storage conditions/Shelf life

- Unlimited shelf life



Dimensions

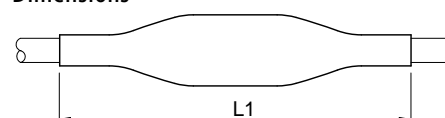

#### Scope of delivery

Outer sleeve, inner sleeves, armour crossover kit, cleaning tissue, emery cloth, assembly instructions

Optional accessory: Compression connectors (see Connecting technology)

		Polymeric cable armoured			
		 4x			
Type	L1 mm	Nominal cross section per conductor mm <sup>2</sup>		Art.-No.	
SMHA4	1.5-10	450	1.5 - 10		145239
	16-50	650	16 - 50		145243
	35-150	850	35 - 150		130945
	95-300	1000	95 - 300		174183

Note: Heat shrinkable connecting joints for shipyard application. Approvals by Lloyd's Register, Germanischer Lloyd and Bureau Veritas on request.





# SMH...G

## Heat shrinkable straight-through joint

for flexible cables

Universally suitable for connecting conductors insulated with EPR (e.g. A07RN-F, H07RN-F). Suitable for compression connectors.

### Characteristics

- Compact dimensions
- Wide conductor and cross-section range
- Resistant to chemical agents
- Resistant to alkaline earth elements
- Stabilized against UV rays
- Free from paint-wetting inhibiting substances
- Halogen-free
- Transversely waterproof
- High electrical insulating values
- High mechanical strength

### Application/Suitability

- Indoor
- Outdoor
- Underground
- Water
- Installation ducts
- Ductwork

### Voltage level

- $U_0/U_m$  (U<sub>m</sub>) 0.6/1 (1.2) kV

### Test standards

- DIN EN 50393 (corresponds to VDE 0278)

### Storage conditions/Shelf life

- Unlimited shelf life



Dimensions

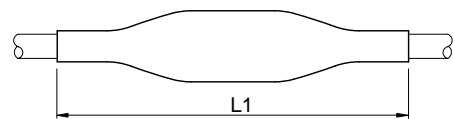

### Scope of delivery

Outer sleeve, inner sleeves, filling material, cleaning tissue, emery cloth, assembly instructions

Optional accessory: Compression connectors (see Connecting technology)

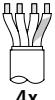
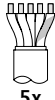
		Polymeric conductor unarmoured		
		 4x	 5x	
Type	L1 mm	Nominal cross section per conductor mm <sup>2</sup>		Art.-No.
SMH4G	1.5-10	450	1.5 - 10	145479
	16-50	550	16 - 50	145481
	35-95	600	35 - 95	145482
	95-150	700	95 - 150	145552
SMH5G	1.5-10	500		1.5 - 10 145483
	10-25	600		10 - 25 145484
	16-50	600		16 - 50 163952

Note: Heat shrinkable connecting joints for shipyard application. Approvals by Lloyd's Register, Germanischer Lloyd and Bureau Veritas on request.



## SMHC...

### Heat shrinkable straight-through joint

for polymeric cables with concentric conductor

Universally suitable for connecting polymeric-insulated cables and conductors with concentric conductors and insulations made of PVC, PE and XLPE (e.g. N(A)YCY, N(A)YC(W)Y, GKN). Suitable for compression connectors.

#### Characteristics

- Compact dimensions
- Wide conductor and cross-section range
- Resistant to chemical agents
- Resistant to alkaline earth elements
- Stabilized against UV rays
- Free from paint-wetting inhibiting substances
- Halogen-free
- Transversely waterproof
- High electrical insulating values
- High mechanical strength

#### Application/Suitability

- Indoor
- Outdoor
- Underground
- Water
- Installation ducts
- Ductwork

#### Voltage level

- $U_0/U_m$  0.6/1 (1.2) kV

#### Test standards

- DIN EN 50393 (corresponds to VDE 0278)

#### Storage conditions/Shelf life

- Unlimited shelf life



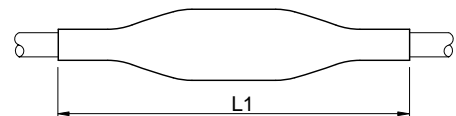

Dimensions



#### Scope of delivery

Outer sleeve, copper braid tape, inner sleeves, armour crossover kit, cleaning tissue, emery cloth, assembly instructions

Optional accessory: Compression connectors (see Connecting technology)

		Polymeric cable with concentric conductor				
						
Type	L1 mm	Nominal cross section per conductor mm <sup>2</sup>			Art.-No.	
SMHC1	10-25	300	10/10 - 25/25			152509
	35-70	400	35/35 - 70/35			152520
	95-240	500	95/50 - 240/95			152521
	150-300	500	150/95 - 300/120			152522
	300-500	600	300/120 - 500/120			152523
SMHC3	4-10*	350		4/4 - 10/10		126672
	16-35*	500		16/16 - 35/35		126674
	50-95*	600		50/50 - 95/95		126675
	120-240*	1000		120/120 - 240/240		126676
SMHC4	4-10*	350			4/4 - 10/10	203028
	16-35*	500			16/16 - 35/16	203029
	50-95*	600			50/25 - 95/50	203040
	120-240*	1000			120/70 - 240/120	203041

\* with additional inner tube

Note: Heat shrinkable connecting joints for shipyard application. Approvals by Lloyd's Register, Germanischer Lloyd and Bureau Veritas on request.



## SMH...E90, SMHC...E90 Heat shrinkable straight-through joint

for fire-resistant cables E90 according to DIN standard 4102 Section 12

For connecting security cables type (N)HXH and (N)HXCH, anywhere where they are required, for example, in power plants, chemical plants, public buildings, airports, tunnels, off-shore installations, fire alarm systems, stairwells, elevator shafts. Suitable for compression connectors.

### Characteristics

- Compact dimensions
- Resistant to chemical agents
- Resistant to alkaline earth elements
- Stabilized against UV rays
- Fire-resistant (see tests)
- Free from paint-wetting inhibiting substances
- Halogen-free
- Transversely waterproof
- High electrical insulating values
- Low smoke and gas emission

### Application/Suitability

- Indoor
- Outdoor
- Underground
- Installation ducts
- Ductwork

### Voltage level

- $U_0/U_m$  0.6/1 (1.2) kV

### Test standards

- DIN VDE 0472 Section 814 (FE180)
- DIN 4102 Section 12, November 1998 (E90)
- IEC 60331-60332

### Storage conditions/Shelf life

- Unlimited shelf life

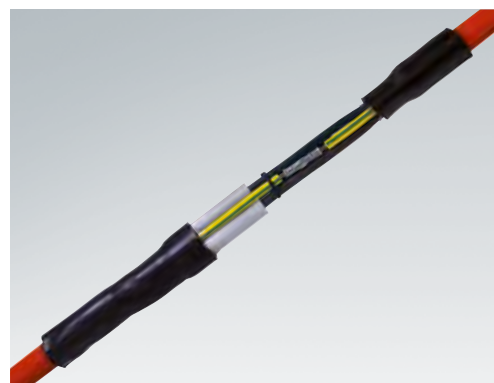

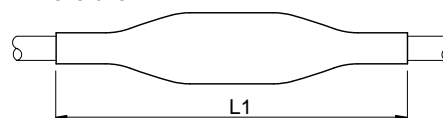

Dimensions



### Scope of delivery

Inner sleeves, insulating tubes, outer sleeve, cleaning tissue, emery cloth, assembly instructions

Optional accessory: Compression connectors (see Connecting technology)

		Polymeric cable			
		unarmoured		with concentric conductor	
					
Type	L1 mm	Nominal cross section per conductor mm <sup>2</sup>			Art.-No.
SMH4	1.5-4 E90	350	1.5 - 4		145653
	6-10 E90	380	6 - 10		145655
	16-25 E90	470	16 - 25		145656
	35-50 E90	500	35 - 50		145657
	70-95 E90	600	70 - 95		145659
	120-150 E90	600	120 - 150		145660
	185-240 E90	750	185 - 240		145661
SMH5	1.5-4 E90	350		1.5 - 4	145680
	6-10 E90	380		6 - 10	145681
	16-25 E90	470		16 - 25	145682
SMHC4	1.5-4 E90	350		1.5/1.5 - 4/4	145665
	6-10 E90	380		6/6 - 10/10	145666
	16-25 E90	470		16/16 - 25/16	145667
	35-50 E90	500		35/16 - 50/25	145668
	70-95 E90	600		70/35 - 95/50	145669
	120-150 E90	600		120/70 - 150/70	145670
	185-240 E90	750		185/95 - 240/120	145671



## SMHF

# Heat shrinkable straight-through joint

for telecommunication cables

For connecting or branching telecommunication cables insulated with PVC or PE (e.g. A-2YF(L)2Y, A-02YSF(L)2Y, A-PWE2Y, A-PM, A-PM2Y, A-PMbc). Suitable for wire connectors.

### Characteristics

- Compact dimensions
- Suitable for cut and uncut cables
- Removable (for repairs or switch-over)
- Resistant to chemical agents
- Resistant to alkaline earth elements
- Stabilized against UV rays
- Free from paint-wetting inhibiting substances
- Halogen-free
- Waterproof and moisture-resistant

### Application/Suitability

- Indoor areas (also with high humidity levels)
- Outdoor
- Underground
- Water
- Installation ducts
- Ductwork

### Test standards

- Type specimen test in accordance with TL-No.5975-3006/0394

### Storage conditions/Shelf life

- Unlimited shelf life

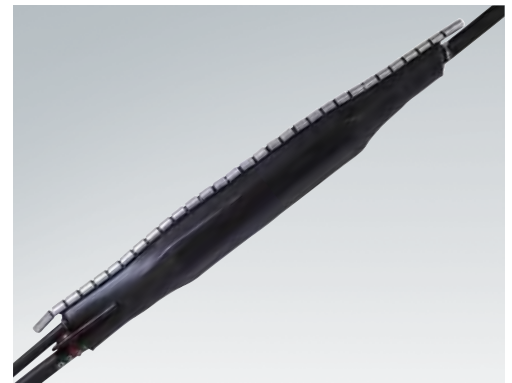

Dimensions

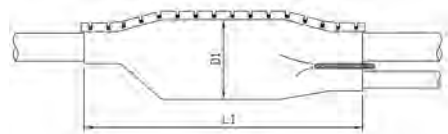

### Scope of delivery

Heat shrinkable sleeve, flexible locking bar, protective liner, drying agent, shield continuity wire with clamps, fire protection film, PVC insulation tape, cleaning tissue, emery cloth, assembly instructions

Optional accessory: Wire connectors AVS (see Connecting technology)  
Assembly kit MSFA (required for each branch)

Type	L1 mm	D1 Ø over protective liner mm	Cable-Ø mm	Telecommunication cable						Art.-No.	
				spliced with wire connector			spliced with conductor connecting blocks				
				0.4 mm	0.6 mm	0.8 mm	0.4 mm	0.6 mm	0.8 mm		
				max. Number of wire pairs							
SMHF	43-8/330	330	43	8 - 35	30	20	10	40	30	20	145559
	43-8/570	570	43	8 - 35	70	40	20	100	70	30	145560
	68-15/380	380	68	15 - 55	100	50	30	150	100	50	145568
	68-15/690	690	68	15 - 55	150	100	50	250	150	70	145564
	93-25/400	400	93	25 - 68	150	100	70	400	250	100	145572
	93-25/690	690	93	25 - 68	200	200	100	500	300	150	145569
	120-28/430	430	120	28 - 94	200	200	150	500	300	200	145574
	120-28/600	600	120	28 - 94	400	300	200	600	400	250	145575
	137-34/725	725	137	34 - 101	600	500	300	800	700	400	145577



## VASMI

### Heat shrinkable straight-through joint

with temperature colour indicator, for telecommunication cables

For connecting or branching telecommunication cables insulated with PVC or PE (e.g. A-2YF(L)2Y, A-02YSF(L)2Y, A-PWE2Y, A-PM, A-PM2Y, A-PMbc). Suitable for wire connectors.

#### Characteristics

- Compact dimensions
- With temperature colour indicator
- Suitable for cut and uncut cables
- Removable (for repairs or switch-over)
- Resistant to chemical agents
- Resistant to alkaline earth elements
- Stabilized against UV rays
- Free from paint-wetting inhibiting substances
- Halogen-free
- Waterproof and moisture-resistant

#### Application/Suitability

- Indoor areas (also with high humidity levels)
- Outdoor
- Underground
- Water
- Installation ducts
- Ductwork

#### Test standards

- Type specimen test in accordance with TL-No.5975-3006/0394

#### Storage conditions/Shelf life

- Unlimited shelf life



Dimensions

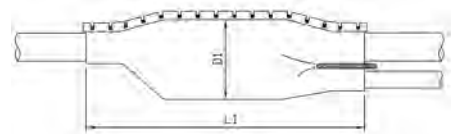

#### Scope of delivery

Heat shrinkable sleeve, flexible locking bar, protective liner, drying agent, shield continuity wire with clamps, fire protection film, PVC insulation tape, cleaning tissue, emery cloth, assembly instructions

Optional accessory: Wire connectors AVS (see Connecting technology)  
Assembly kit MSFA (required for each branch)

Type	L1 mm	D1 Ø over protective liner mm	Cable-Ø mm	Telecommunication cable						Art.-No.	
				spliced with wire connector			spliced with conductor connecting blocks				
				0.4 mm	0.6 mm	0.8 mm	0.4 mm	0.6 mm	0.8 mm		
				max. Number of wire pairs							
VASMI	1 SRT	330	43	8 - 35	30	20	10	40	30	20	145562
	1 L SRT	390	43	8 - 35	70	40	20	100	70	30	145561
	2 SRT	380	68	15 - 55	100	50	30	150	100	50	145566
	2 L SRT	450	68	15 - 55	150	100	50	250	150	70	145565
	3 SRT	400	93	25 - 68	150	100	70	400	250	100	145571
	3 L SRT	500	93	25 - 68	200	200	100	500	300	150	145570
	4 L SRT	430	120	28 - 94	200	200	150	500	300	200	145573
	5 L SRT	600	120	28 - 94	400	300	200	600	400	250	153392
6 L SRT	725	137	34 - 101	600	500	300	800	700	400	145576	



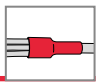

## SM, SM-MA

### Heat shrinkable universal straight-through joint

for polymeric cables, conductors and mass-impregnated paper cables

Universally suitable for connecting polymeric cables or conductors insulated with PVC, PE and XLPE (e.g. GKN, GN-CLN). With extra transition set to connect with mass-impregnated paper cables (GKN-PPb, GN-CLN-PPb). Suitable for compression connectors.

#### Characteristics

- Compact dimensions
- Wide conductor and cross-section range
- Resistant to chemical agents
- Resistant to alkaline earth elements
- Stabilized against UV rays
- Free from paint-wetting inhibiting substances
- Halogen-free
- Transversely waterproof
- High electrical insulating values
- High mechanical strength
- Ready for immediate operation

#### Application/Suitability

- Indoor
- Outdoor
- Underground
- Water
- Installation ducts
- Ductwork

#### Voltage level

- $U_0/U (U_m)$  0.6/1 (1.2) kV

#### Note

- Straight-through joint for 4-core cables, e.g. GKN, GN-CLN

#### Test standards

- DIN EN 50393 (corresponds to VDE 0278)

#### Storage conditions/ Shelf life

- Unlimited shelf life

#### Scope of delivery

Outer sleeve, copper braid tape, inner protective sleeve (belt sleeve), inner sleeves, cleaning tissue, emery cloth, assembly instructions

Optional accessory: Compression connectors (see Connecting technology)  
Accessory kit ZS-PPb (required for PPb cables)



Particularly for the  
Swiss market



#### Dimensions

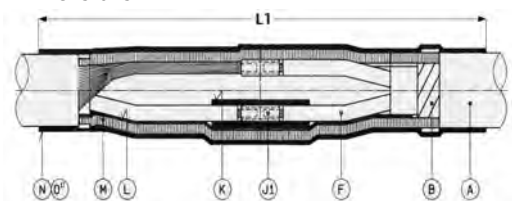

GKN – GN-CLN

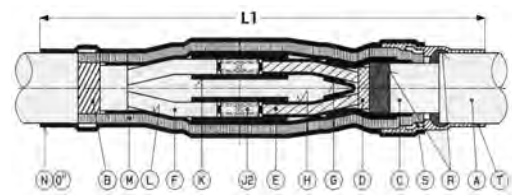

GN-CLN – PPb

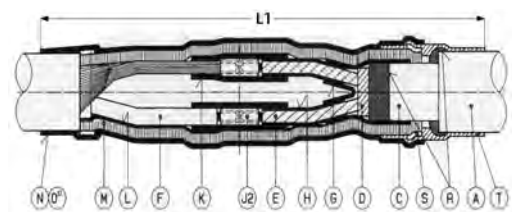

GKN – PPb

- A = Outer sheath
- B = CL armouring
- C = Lead sheath
- D = Paper belt
- E = Paper insulated conductor
- F = Conductor
- G = Spreader cap SEMH4
- H = Heat shrinkable tube SR2
- J1 = Connector
- J2 = Connector with separator
- K = Heat shrinkable tube SRH3
- L = High voltage insulation tape No. 62/38 mm
- M = Copper braid tape No. 63/60 mm
- N/O = Heat shrinkable cuff / Outer sleeve SRH2
- R = Mastic tape HKB
- S = High voltage insulation tape No. 62/19 mm
- T = Heat shrinkable tube SRH

→ Continued on the next page



→ Continuation

## SM, SM-MA Heat shrinkable universal straight-through joint



Particularly for the Swiss market

Polymeric cable unarmoured / armoured		Mass-impregnated paper cable (with accessory kit ZS-PPb)
 4x		 4x

Type	L1 mm	Nominal cross section per conductor mm <sup>2</sup>		Art.-No.	
<b>Heat shrinkable tube for outer protection</b>					
<b>SM</b>	4-10	400	4 - 10	4 - 10	126713
	16-50	500	16 - 50	16 - 35	126714
	50-95	750	50 - 95	50 - 95	126715
	95-150	850	95 - 150	95 - 150	180739
	120-240	1000	120 - 240	120 - 240	126716
<b>Sleeve for outer protection</b>					
<b>SM-MA</b>	4-10	400	4 - 10	4 - 10	126717
	16-50	500	16 - 50	16 - 35	126696
	50-95	750	50 - 95	50 - 95	126697
	95-150	850	95 - 150	95 - 150	180760
	120-240	1000	120 - 240	120 - 240	126698



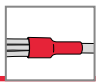

## ZS-PPb Accessory kit

for mass-impregnated paper cables for heat shrinkable universal straight-through joints SM and SM-MA

To build a transition joint for mass-impregnated paper cables for the heat shrinkable universal straight-through joints.

### Characteristics

- Compact dimensions
- Wide conductor and cross-section range
- Resistant to chemical agents
- Resistant to alkaline earth elements
- Stabilized against UV rays
- Free from paint-wetting inhibiting substances
- Halogen-free
- High electrical insulating values
- High mechanical strength

### Application/Suitability

- For heat shrinkable universal straight-through joints SM and SM-MA

### Voltage level

- $U_0/U_m$  0.6/1 (1.2) kV

### Test standards

- DIN EN 50393 (corresponds to VDE 0278)



### Scope of delivery

Spreader cap, heat shrinkable tubes, roughening strip



Particularly for the  
Swiss market

Type	Art.-No.	
ZS-PPb	4-10	126773
	16-35	126769
	50-95	126770
	95-150	180761
	120-240	126771



## SMDH

### Heat shrinkable straight-through joint

for armoured polymeric cables

Universally suitable for connecting light armoured polymeric cables insulated with PVC, PE and XLPE (e.g. GN-CLN). Suitable for compression connectors.

#### Characteristics

- Compact dimensions
- Wide conductor and cross-section range
- Resistant to chemical agents
- Resistant to alkaline earth elements
- Stabilized against UV rays
- Free from paint-wetting inhibiting substances
- Halogen-free
- Transversely waterproof
- High electrical insulating values
- High mechanical strength
- Ready for immediate operation

#### Application/Suitability

- Indoor
- Outdoor
- Underground
- Water
- Installation ducts
- Ductwork

#### Voltage level

- $U_0/U_m$  (U<sub>m</sub>) 0.6/1 (1.2) kV

#### Test standards

- DIN EN 50393 (corresponds to VDE 0278)

#### Storage conditions/Shelf life

- Unlimited shelf life

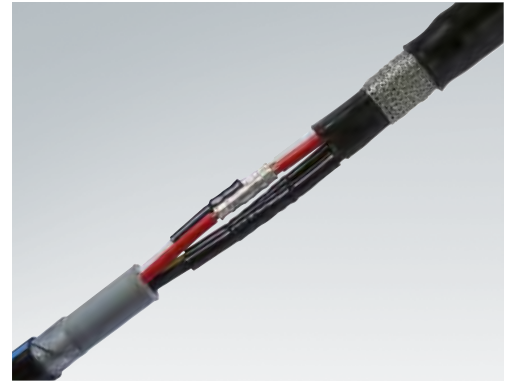

Dimensions

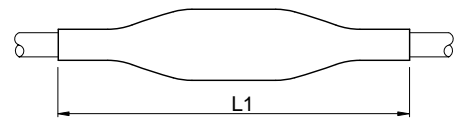

#### Scope of delivery

Outer sleeve, copper braid tape, inner protective sleeve (belt sleeve), inner sleeves, cleaning tissue, emery cloth, assembly instructions

Optional accessory: Compression connectors (see Connecting technology)



Particularly for the Swiss market

Polymeric cable	
armoured	
 4x	

Type	L1 mm	Nominal cross section per conductor mm <sup>2</sup>	Art.-No.	
SMDH	1.5-10	330	1.5 - 10	126740
	16-35	500	16 - 35	126719
	50-95	800	50 - 95	126720
	120-240	1000	120 - 240	126721

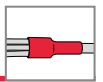

**EASY-FIX** **NEW**  
**SRMH Cable repair kit**

for damaged cables and conductors

For fast connecting and insulation of drilled or otherwise damaged cables without the necessity to insert the new lines. The cable repair kit restores the electric and mechanical properties in the installed cable.

**Characteristics**

- With hot melt adhesive
- Resistant to chemical agents
- Stabilized against UV rays
- Free from paint-wetting inhibiting substances
- High flexibility
- High tensile strength
- Resistant to cold flow (thermally stable)
- Self-extinguishing

**Application/Suitability**

- For repairing of damaged sheaths of all plastic- and rubber-insulated cables and conductors

**Storage conditions/Shelf life**

- Unlimited shelf life



**Scope of delivery**

SRMH3: 1 heat shrinkable tube, 3 heat shrinkable crimp connectors, 4 cable ties

SRMH5: 1 heat shrinkable tube, 5 heat shrinkable crimp connectors, 5 cable ties

Note: Sales display with 20 SRMH cable repair kits, packed individually.

Polymeric cable unarmoured		
	 3x	
Type	Nominal cross section per conductor mm <sup>2</sup>	Art.-No.
SRMH3	1.5 - 2.5	254684
SRMH5	1.5 - 2.5	345619



## SMH4...Pb-RF

### Heat shrinkable transition joint

with solderless earthing wire connection, for polymeric cables and mass-impregnated paper cables

Universally suitable for transition from mass-impregnated paper cables to polymeric-insulated cables made of PVC, PE and XLPE, e.g. N(A)KBA on N(A)YY. Suitable for compression connectors on aluminium or copper cables.

#### Characteristics

- Compact dimensions
- Wide conductor and cross-section range
- Resistant to chemical agents
- Resistant to alkaline earth elements
- Stabilized against UV rays
- Free from paint-wetting inhibiting substances
- Halogen-free
- Transversely waterproof
- High electrical insulating values
- High mechanical strength

#### Application/Suitability

- Indoor
- Outdoor
- Underground
- Water
- Installation ducts
- Ductwork

#### Voltage level

- $U_0/U_m$  0.6/1 (1.2) kV

#### Test standards

- DIN EN 50393 (corresponds to VDE 0278)

#### Storage conditions/Shelf life

- Unlimited shelf life



Dimensions

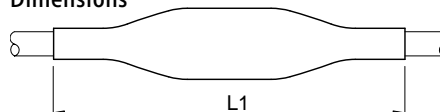



#### Scope of delivery

Outer sleeve, earthing wire, pressure spring, spreader cap, inner sleeves, core insulating tubes, cleaning tissue, emery cloth, assembly instructions

Optional accessory: Compression connectors (see Connecting technology)

Note: Use only connectors with separator.

Type	L1 mm	Polymeric cable	Mass-impregnated paper cable	Art.-No.	
		unarmoured			
		 4x	 4x		
		Nominal cross section per conductor mm <sup>2</sup>			
SMH4	25-70 Pb-RF	800	25 - 70	25 - 70	150825
	70-150 Pb-RF	1000	70 - 150	70 - 150	145354
	150-300 Pb-RF	1200	150 - 300	150 - 300	150826



## SMHSV4...Pb-RF

### Heat shrinkable transition joint

with screw connectors, with solderless earthing wire connection, for polymeric cables and mass-impregnated paper cables

Universally suitable for transition from mass-impregnated paper cables to polymeric-insulated cables made of PVC, PE and XLPE, e.g. NAKLEY, N(A)KBA on N(A)YY. With mechanical connectors with shear heads bolts suitable for aluminium or copper cables.

#### Characteristics

- Compact dimensions
- Wide conductor and cross-section range
- Resistant to chemical agents
- Resistant to alkaline earth elements
- Stabilized against UV rays
- Free from paint-wetting inhibiting substances
- Halogen-free
- Transversely waterproof
- High electrical insulating values
- High mechanical strength

#### Application/Suitability

- Indoor
- Outdoor
- Underground
- Water
- Installation ducts
- Ductwork

#### Voltage level

- $U_0/U_m$  0.6/1 (1.2) kV

#### Test standards

- DIN EN 50393 (corresponds to VDE 0278)

#### Storage conditions/Shelf life

- Unlimited shelf life



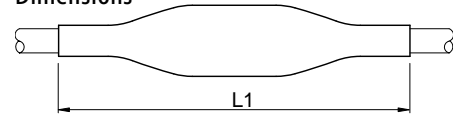

Dimensions



#### Scope of delivery

Outer sleeve, earthing wire, pressure spring, spreader cap, inner sleeves, screw connectors CSV-T with shear head bolts, core insulating tubes, cleaning tissue, emery cloth, assembly instructions

Type	L1 mm	Polymeric cable		Mass-impregnated paper cable		Art.-No.
		unarmoured		NAKLEY	N(A)KBA	
						
		4x		3x	4x	
		Nominal cross section per conductor mm <sup>2</sup>				
SMHSV4	6-50 Pb-RF	750	6 - 50	6 - 50	6 - 35	268322
	25-95 Pb-RF	900	25 - 95	25 - 95	25 - 70	268323
	50-150 Pb-RF	1000	50 - 150	50 - 150	50 - 120	268324
	95-240 Pb-RF	1200	95 - 240	95 - 240	95 - 185	307669



## SEMH4-K

### Voltage-resistant pot end joint

with inner caps and outer cap, for polymeric cables and conductors

Universal pot end cable terminations of unarmoured polymeric-insulated cables and conductors as well as polymeric-insulated cables with concentric conductors with insulation made of PVC, PE and XLPE, e.g. N(A)YY, N(A)XY, TT, GKN, GN-CLN, N(A)2Y2Y, N(A)2X2Y, N(A)YC(W)Y.

#### Characteristics

- Wide conductor and cross-section range
- Resistant to chemical agents
- Resistant to alkaline earth elements
- Stabilized against UV rays
- Free from paint-wetting inhibiting substances
- Halogen-free
- Transversely waterproof
- High electrical insulating values
- High mechanical strength

#### Application/Suitability

- Indoor
- Outdoor
- Underground
- Water
- Installation ducts
- Ductwork

#### Voltage level

- $U_0/U_m$  0.6/1 (1.2) kV

#### Test standards

- DIN EN 50393 (corresponds to VDE 0278)

#### Storage conditions/Shelf life

- Unlimited shelf life



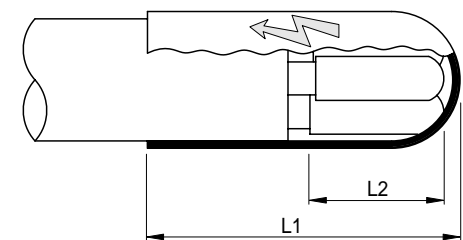

#### Dimensions



#### Scope of delivery

Sealing caps, heat shrinkable cap with voltage arrow, cleaning tissue, emery cloth, assembly instructions

Polymeric cable	
unarmoured	with concentric conductor
 4x	 3x

Type	L1 mm	L2 mm	Nominal cross section per conductor mm <sup>2</sup>	Art.-No.
SEMH4-K	6-25	105	6 - 25	145388
	35-150	145	35 - 150	145386
	185-300	140	185 - 300	145391



## SEMH

### Voltage-resistant pot end joint

with inner sleeves and outer cap, for polymeric cables and conductors

Universal pot end cable terminations of unarmoured polymeric-insulated cables and conductors as well as polymeric-insulated cables with concentric conductors with insulation made of PVC, PE and XLPE, e.g. N(A)YY, N(A)XY, TT, GKN, GN-CLN, N(A)2Y2Y, N(A)2X2Y, N(A)YC(W)Y.

#### Characteristics

- Wide conductor and cross-section range
- Resistant to chemical agents
- Resistant to alkaline earth elements
- Stabilized against UV rays
- Free from paint-wetting inhibiting substances
- Halogen-free
- Transversely waterproof
- High electrical insulating values
- High mechanical strength

#### Application/Suitability

- Indoor
- Outdoor
- Underground
- Water
- Installation ducts
- Ductwork

#### Voltage level

- $U_0/U_m$  0.6/1 (1.2) kV

#### Test standards

- DIN EN 50393 (corresponds to VDE 0278)

#### Storage conditions/Shelf life

- Unlimited shelf life



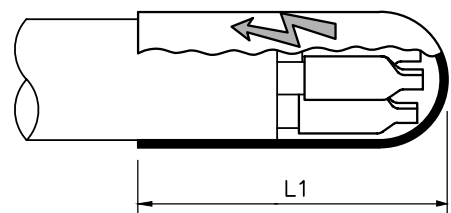

Dimensions

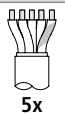

#### Scope of delivery

Sealing tubes, heat shrinkable cap with voltage arrow, assembly instructions

		Polymeric cable			
		unarmoured		with concentric conductor	
					
		5x		4x	
Type	L1 mm	Nominal cross section per conductor mm <sup>2</sup>		Art.-No.	
SEMH5	6-25	6 - 25		6/6 - 25/25	
	100			145387	



## SEMHK4...Pb

### Voltage-resistant pot end joint

with inner cap, for mass-impregnated paper cables

Pot end cable terminations for mass-impregnated paper cables (e.g. N(A)KBA, NAKLEY, PPb).

#### Characteristics

- Wide conductor and cross-section range
- Resistant to chemical agents
- Resistant to alkaline earth elements
- Stabilized against UV rays
- Free from paint-wetting inhibiting substances
- Halogen-free
- Transversely waterproof
- High electrical insulating values
- High mechanical strength

#### Application/Suitability

- Indoor
- Outdoor
- Underground
- Water
- Installation ducts
- Ductwork

#### Voltage level

- $U_0/U_m$  0.6/1 (1.2) kV

#### Test standards

- DIN EN 50393 (corresponds to VDE 0278)

#### Storage conditions/Shelf life

- Unlimited shelf life



#### Dimensions

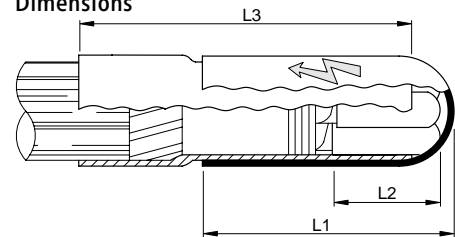

#### Scope of delivery

Sealing tube, heat shrinkable cap with voltage arrow, sealing caps, cleaning tissue, emery cloth, assembly instructions

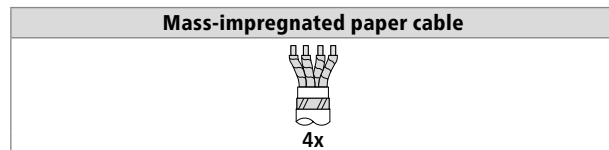

Type	L1 mm	L2 mm	L3 mm	Nominal cross section per conductor mm <sup>2</sup>	Art.-No.
SEMHK4	16-50 Pb	75	50	200	145396
	70-120 Pb	145	70	200	145397
	95-300 Pb	140	100	250	145398



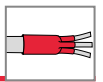

## SFEX

### Heat shrinkable cable termination

for unarmoured polymeric cables and conductors

Universally suitable for connecting the polymeric-insulated cables to electrical equipment, for cables insulated with PE, XLPE, PVC and cable sheaths insulated with PVC or PE. Suitable for compression cable lugs on aluminium and copper cables.

#### Characteristics

- Compact dimensions
- Wide conductor and cross-section range
- Resistant to chemical agents
- Stabilized against UV rays
- Free from paint-wetting inhibiting substances
- Halogen-free
- 100 % waterproof
- High electrical insulating values
- High mechanical strength

#### Application/Suitability

- Outdoor

#### Voltage level

- $U_0/U_m$  0.6/1 (1.2) kV

#### Note

- SFEX4 for power cables and conductors with green-yellow wire marking

#### Test standards

- DIN EN 50393 (corresponds to VDE 0278)

#### Storage conditions/Shelf life

- Unlimited shelf life



#### Dimensions

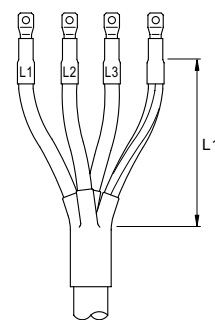

#### Scope of delivery

Core insulating tubes, spreader cap, sealing tubes, cleaning tissue, emery cloth, assembly instructions

Optional accessory: Compression cable lugs (see Connecting technology)

Note: Waterproof cable lugs must be used for outdoor cable terminations.

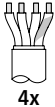
		Polymeric cable unarmoured			
		 4x			
Type	L1 mm	Nominal cross section per conductor mm <sup>2</sup>		Art.-No.	
SFEX4	4-16	300	4 - 16		145436
	25-50	400	25 - 50		145439
	70-150	500	70 - 150		145444
	150-300	500	150 - 300		145449



## SFEH

### Heat shrinkable cable termination

for unarmoured polymeric cables

Universally suitable to terminate polymeric cables and electrical equipment. Suitable for cables insulated with PE, VPE, PVC und cable sheaths insulated with PVC or PE suitable for compression lugs on aluminium and copper conductors.

#### Characteristics

- Compact dimensions
- Wide conductor and cross-section range
- Resistant to chemical agents
- Stabilized against UV rays
- Free from paint-wetting inhibiting substances
- Halogen-free
- High electrical insulating values
- High mechanical strength

#### Application/Suitability

- Indoor

#### Voltage level

- $U_0/U_m$  0.6/1 (1.2) kV

#### Test standards

- DIN EN 50393 (corresponds to VDE 0278)

#### Storage conditions/Shelf life

- Unlimited shelf life



#### Dimensions

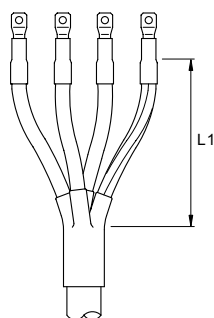

L1 = user-defined

#### Scope of delivery

Spreader cap, sealing tubes, cleaning tissue, emery cloth, assembly instructions

Optional accessory: Compression cable lugs (see Connecting technology)

Polymeric cable	
unarmoured	
 4x	

Type	Nominal cross section per conductor mm <sup>2</sup>	Art.-No.
SFEH4	1.5-6	145434
	4-16	145435
	25-50	145438
	70-150	145443
	150-300	145448

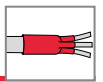

# SESCW

## Heat shrinkable cable termination

for polymeric cables with concentric conductor

Universally suitable to terminate polymeric cables with concentric conductor and electrical equipment. Suitable for cables insulated with PVC, cable sheaths insulated with PVC and PE and for compression connectors on aluminium and copper conductors.

### Characteristics

- Compact dimensions
- Wide conductor and cross-section range
- Resistant to chemical agents
- Stabilized against UV rays
- Free from paint-wetting inhibiting substances
- Halogen-free
- 100 % waterproof
- High electrical insulating values
- High mechanical strength

### Application/Suitability

- Indoor
- Outdoor

### Voltage level

- $U_0/U_m$  0.6/1 (1.2) kV

### Test standards

- DIN EN 50393 (corresponds to VDE 0278)

### Storage conditions/Shelf life

- Unlimited shelf life



### Dimensions

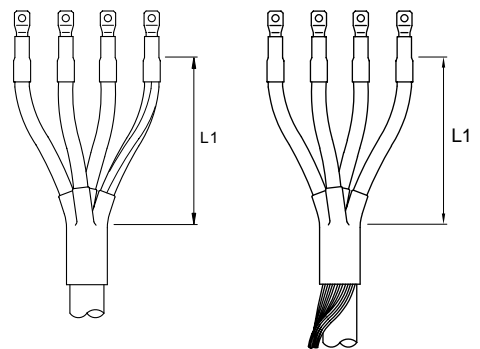



### Scope of delivery

Spreader cap, sealing tubes, insulating tube for concentric conductor (Ceander), cleaning tissue, emery cloth, assembly instructions

Optional accessory: Compression cable lugs (see Connecting technology)

Note: Waterproof cable lugs must be used for outdoor cable terminations.

Polymeric cable	
with concentric conductor	
 3x	 4x

Type	L1 mm	Nominal cross section per conductor mm <sup>2</sup>		Art.-No.
SESCW	4-16	300	4/4 - 16/16	148168
	25-50	400	25/25 - 50/50	154637
	70-150	500	70/70 - 150/150	145401
	150-300	500	150/150 - 300/300	145400

**SESPB****Heat shrinkable cable termination**

for mass-impregnated paper cables

Universally suitable for connecting mass-impregnated paper cables to electrical equipment. Suitable for compression lugs on aluminium and copper conductors.

**Characteristics**

- Compact dimensions
- Wide conductor and cross-section range
- Resistant to chemical agents
- Stabilized against UV rays
- Free from paint-wetting inhibiting substances
- Halogen-free
- 100 % waterproof
- High electrical insulating values
- High mechanical strength

**Application/Suitability**

- Indoor
- Outdoor

**Voltage level**

- $U_0/U_m$  0.6/1 (1.2) kV

**Test standards**

- DIN EN 50393 (corresponds to VDE 0278)

**Storage conditions/Shelf life**

- Unlimited shelf life

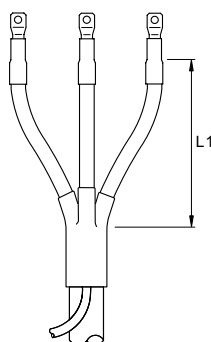
**Dimensions****Scope of delivery**

Core insulating tubes, spreader cap, sealing tubes, earthing accessories, cleaning tissue, emery cloth, assembly instructions

Optional accessory: Compression cable lugs (see Connecting technology)

Note: Waterproof cable lugs must be used for outdoor cable terminations.

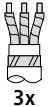
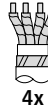
		Mass-impregnated paper cable		
		 3x	 4x	
Type	L1 mm	Nominal cross section per conductor mm <sup>2</sup>		Art.-No.
SESPB3	25-35	25 - 35		180231
	50-70	50 - 70		193415
	95-150	95 - 150		145403
SESPB4	4-16	4 - 16		145402
	25-35	25 - 35		145405
	50-70	50 - 70		145406
	95-150	95 - 150		145407
	185-300	185 - 300		145408

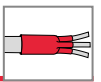

# SEH4...V-S Heat shrinkable indoor cable termination

for armoured polymeric cables

For connecting polymeric cables to distribution cupboards and panels. Suitable for PVC and XLPE insulated cables and PVC and PE cable sheaths with protective armouring (e.g. GN-CLN). Suitable for compression lugs on aluminium and copper conductors.

### Characteristics

- Compact dimensions
- Wide conductor and cross-section range
- Resistant to chemical agents
- Stabilized against UV rays
- Free from paint-wetting inhibiting substances
- Halogen-free
- Transversely waterproof
- High electrical insulating values
- High mechanical strength
- Ready for immediate operation

### Application/Suitability

- Indoor
- Voltage level**
- $U_0/U_m$  0.6/1 (1.2) kV
- Test standards**
- DIN EN 50393 (corresponds to VDE 0278)
- Storage conditions/Shelf life**
- Unlimited shelf life

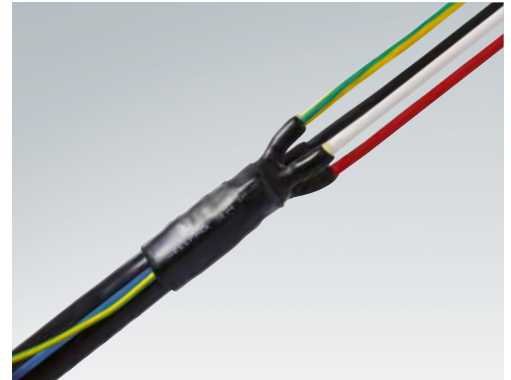

### Dimensions

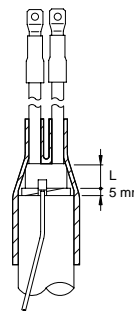

### Scope of delivery

Sealing tubes, spreader cap, cleaning tissue, emery cloth, assembly instructions

Optional accessory: Compression cable lugs (see Connecting technology)

Particularly for the Swiss market

Polymeric cable	
armoured	
 4x	

Type	L mm	Nominal cross section per conductor mm <sup>2</sup>	Art.-No.
SEH4	4-10 V-S	4 - 10	131998
	10-35 V-S	10 - 35	131999
	95-150 V-S	95 - 150	126821

**SEH4...V-C****Heat shrinkable indoor cable termination**

for polymeric cables with concentric conductor

For connecting polymeric cables to distribution cupboards and panels. Suitable for PVC and XLPE insulated cables and PVC and PE cable sheaths with concentric conductor (e.g. GKN). Suitable for compression lugs on aluminium and copper conductors.

**Characteristics**

- Compact dimensions
- Wide conductor and cross-section range
- Resistant to chemical agents
- Stabilized against UV rays
- Free from paint-wetting inhibiting substances
- Halogen-free
- Transversely waterproof
- High electrical insulating values
- High mechanical strength
- Ready for immediate operation

**Application/Suitability**

- Indoor

**Voltage level**

- $U_0/U_m$  0.6/1 (1.2) kV

**Test standards**

- DIN EN 50393 (corresponds to VDE 0278)

**Storage conditions/Shelf life**

- Unlimited shelf life

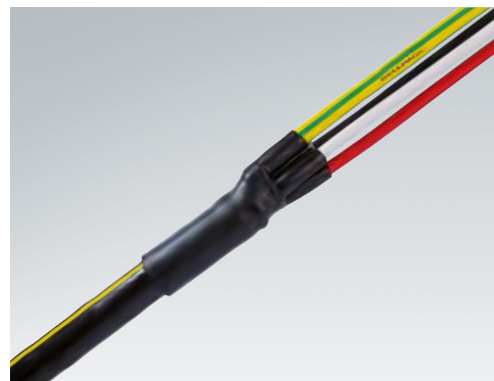
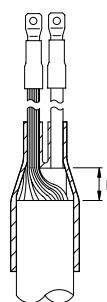
**Dimensions****Scope of delivery**

Sealing tubes, heat shrinkable tube (Green-Yellow), spreader cap, cleaning tissue, emery cloth, assembly instructions

Optional accessory: Compression cable lugs (see Connecting technology)



Particularly for the  
Swiss market

**Polymeric cable  
with concentric conductor**

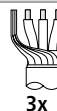

3x

Type	L mm	Nominal cross section per conductor mm <sup>2</sup>	Art.-No.	
SEH4	4-10 V-C	20	4/4 - 10/10	131100
	10-35 V-C	20	10/10 - 35/35	126822
	50-95 V-C	20	50/50 - 95/95	126823
	95-150 V-C	20	95/50 - 150/70	126832
	120-240 V-C	20	120/70 - 240/120	126824

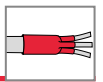

## SEH4...S-C

### Heat shrinkable indoor cable termination

for polymeric cables with concentric conductor

For connecting polymeric cables to distribution cupboards and panels. Suitable for PVC and XLPE insulated cables and PVC and PE cable sheaths with concentric conductor (e.g. GKN). Suitable for compression lugs on aluminium and copper conductors.

#### Characteristics

- Compact dimensions
- Wide conductor and cross-section range
- Resistant to chemical agents
- Stabilized against UV rays
- Free from paint-wetting inhibiting substances
- Halogen-free
- Transversely waterproof
- High electrical insulating values
- High mechanical strength
- Ready for immediate operation

#### Application/Suitability

- Indoor
- Voltage level**
- $U_0/U_m$  0.6/1 (1.2) kV
- Test standards**
- DIN EN 50393 (corresponds to VDE 0278)
- Storage conditions/Shelf life**
- Unlimited shelf life

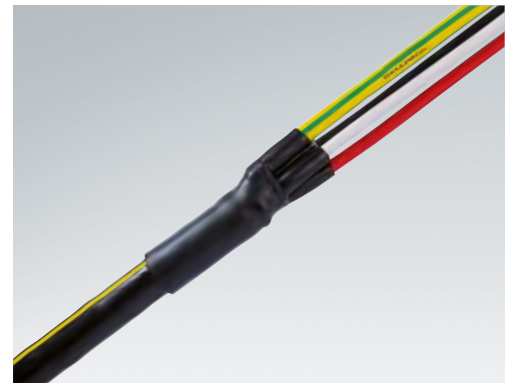

#### Dimensions

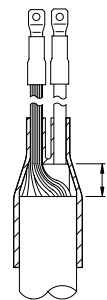

#### Scope of delivery

Sealing tubes, heat shrinkable tube (Green-Yellow), spreader cap, cleaning tissue, emery cloth, assembly instructions

Optional accessory: Compression cable lugs (see Connecting technology)



Particularly for the  
Swiss market

#### Polymeric cable with concentric conductor



3x

Type	L mm	Nominal cross section per conductor mm <sup>2</sup>	Art.-No.	
SEH4	4-10 S-C	10	4/4 - 10/10	126854
	10-35 S-C	20	10/10 - 35/35	126855
	50-95 S-C	20	50/50 - 95/95	126856
	95-150 S-C	20	95/50 - 150/70	126847
	120-240 S-C	20	120/70 - 240/120	126857



## SEH4...A+Z

### Heat shrinkable indoor and outdoor cable termination

for polymeric cable with concentric conductor and armoured polymeric cables, with or without connectors

Universally suitable for connecting polymeric cables and cable sheaths insulated with PVC and PE with concentric conductor (e.g. GKN) or protective armour (e.g. GN-CLN). Suitable for compression lugs or compression connectors on aluminium and copper conductors.

#### Characteristics

- Compact dimensions
- Wide conductor and cross-section range
- Resistant to chemical agents
- Stabilized against UV rays
- Free from paint-wetting inhibiting substances
- Halogen-free
- Transversely waterproof
- High electrical insulating values
- High mechanical strength
- Ready for immediate operation

#### Application/Suitability

- Indoor
- Outdoor
- For double compression connectors with separators complying with DIN 46267

#### Voltage level

- $U_0/U_m$  0.6/1 (1.2) kV

#### Test standards

- DIN EN 50393 (corresponds to VDE 0278)

#### Storage conditions/Shelf life

- Unlimited shelf life



#### Dimensions

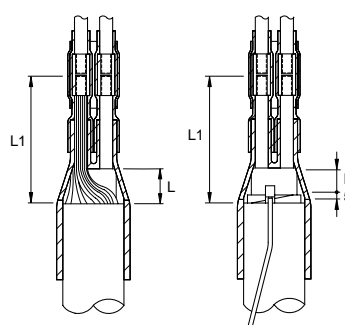

#### Scope of delivery



Sealing tubes, spreader cap, core insulating tubes, double compression connectors (according to type, on choice), cleaning tissue, emery cloth, assembly instructions

Optional accessory: Compression cable lugs (see Connecting technology)  
Compression connectors (see Connecting technology)

Note: Use only connectors with separator.



Particularly for the Swiss market

Polymeric cable	
with concentric conductor	armoured
 3x	 4x

Type	L mm	L1 mm	Nominal cross section per conductor mm <sup>2</sup>		Art.-No.	
<b>incl. 4 compression type connectors with separator</b>						
SEH4	10 A+Z	20	85	10/10	10	126803
	16 A+Z	20	85	16/16	16	126804
	25 A+Z	20	85	25/25	25	126805
	35 A+Z	20	105	35/35	35	126806
	50 A+Z	20	105	50/50	50	126807
	70 A+Z	20	105	70/70	70	126808
	95 A+Z	20	115	95/95	95	126809
	120 A+Z	20	115	120/120	120	126810
150 A+Z	20	115	150/150	150	126811	
<b>without connectors</b>						
SEH4	6-25 A+Z	20	105	6/6 - 25/25	6 - 25	126797
	35-95 A+Z	20	125	35/35 - 95/95	35 - 95	126798
	95-150 A+Z	20	125	95/95 - 150/150	95 - 150	180762
	120-240 A+Z	20	155	120/120 - 240/240	120 - 240	126799



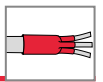

## SR2LK, SR2LK-PEN Heat shrinkable tube kit

for phase marking

Universally suitable for phase marking, for polymeric-insulated cables and conductors in connection area.

### Characteristics

- Resistant to chemical agents
- Stabilized against UV rays
- Halogen-free
- Non-corrosive
- Infusible
- Superior electrical properties
- High mechanical strength
- Resistant to cold flow (thermally stable)

### Application/Suitability

- Phase marking

### Material

- Cross-linked polyolefin
- Free of lead and cadmium

### Storage conditions/Shelf life

- Unlimited shelf life



### Colours



Black

### Scope of delivery

SR2LK: Black heat shrinkable tube with white markings,

1 kit = L1, L2, L3, N per each piece

SR2LK-PEN: Black heat shrinkable tube with white markings,

1 kit = L1, L2, L3, PEN per each piece

Note: Green-Yellow heat shrinkable tube with black inscription on request.

Type	L mm	Inner-Ø mm		Recovered wall thickness mm	Art.-No.
		before shrinking	after shrinking		
<b>Imprint: L1, L2, L3, N</b>					
SR2LK	25-70	50	22	6	145093
	70-240	80	40	12	145096
	150-500	125	56	17	145097
<b>Imprint: L1, L2, L3, PEN</b>					
SR2LK-PEN	25-70	50	22	6	165612
	70-240	80	40	12	154982



# SHE

## Heat shrinkable wall duct

for cables and conductors

Universally suitable for insertion of all types of cables and conduits through building walls.

### Characteristics

- Wide conductor and cross-section range
- Sealant-coated on the inside
- Resistant to alkaline earth elements
- Stabilized against UV rays
- Free from paint-wetting inhibiting substances
- Halogen-free
- 100 % waterproof
- Gas-tight up to 0.2 bar
- Longitudinally watertight up to 1.0 bar
- High mechanical strength

### Application/Suitability

- Mechanical protection for cables and conduits routed through walls

### Note

- For very thick walls two wall ducts may be joined together. To seal the wall duct, we recommend our putty/sealing compound LG or universal sealing compound DUCT SEAL and to centre the wall duct to use our KZ centering aid, which consists of PE foam.

### Storage conditions/Shelf life

- Unlimited shelf life



### Scope of delivery

Wall duct, assembly instructions

Optional accessory: Putty/sealing compound LG (see Accessories)  
 Universal sealing compound DUCT SEAL (see Accessories)  
 Centring aid KZ (see Accessories)

Type	L1 mm	Cable-Ø mm	Inner-Ø mm		max. Wall thickness mm	Wall breakthrough mm	Art.-No.	
			before shrinking	after shrinking				
SHE	14-8	800	8 - 14	25	6	500	40	145600
	26-12	800	12 - 26	35	10	500	55	145604
	41-16	800	16 - 41	47	16	500	70	145616
	54-26	800	26 - 54	65	25	500	90	145611
	95-54	800	54 - 95	115	35	500	140	145614



## Overview: Cellpack Heat shrinkable tubes

Products	Properties					
	with adhesive	without adhesive	black	coloured	halogen-free	self-extinguishing
<b>Thin wall heat shrinkable tubes</b>						
<b>Shrink ratio 2:1</b>						
<b>SRC1</b>	–	●	●	–	●	–
<b>SR1F</b>	–	●	●	●	–	●
<b>SB</b>	–	●	●	●	–	●
<b>SBS</b>	–	●	●	–	–	●
<b>Shrink ratio 3:1</b>						
<b>SR1F3</b>	–	●	●	●	–	●
<b>SB</b>	–	●	●	●	–	●
<b>Medium wall heat shrinkable tubes</b>						
<b>Shrink ratio 3:1</b>						
<b>SRUM</b>	●	–	●	–	–	●
<b>SR2</b>	–	●	●	●	●	–
<b>SRH2</b>	●	–	●	–	●	–
<b>SRFH2</b>	●	–	●	–	–	●
<b>Shrink ratio 4:1</b>						
<b>SRUM</b>	●	–	●	–	–	●
<b>Thick wall heat shrinkable tubes</b>						
<b>Shrink ratio 3:1</b>						
<b>SR3</b>	–	●	●	–	●	–
<b>SRH3</b>	●	–	●	–	●	–
<b>SRFH3</b>	●	–	●	–	–	●
<b>SRBK</b>	●	–	●	–	●	–

- available
- not available



# SRC1 Heat shrinkable thin wall tube

halogen-free, shrink ratio 2 : 1, without adhesive

### Characteristics

- Thin wall
- Inscrutable
- Resistant to chemical agents
- Stabilized against UV rays
- Free from paint-wetting inhibiting substances
- Halogen-free
- Non-corrosive
- Infusible
- High flexibility
- Superior electrical properties
- High tensile strength
- Resistant to cold flow (thermally stable)

### Application/Suitability

- Insulating
- Bundling
- Marking
- Corrosion protection
- Mechanical protection

### Material

- Cross-linked polyolefin
- Free of lead and cadmium

### Test standards

- Corresponds to MIL-I-23053/5 class 1 and 2

### Storage conditions/Shelf life

- Unlimited shelf life



### Colours



Black

### Scope of delivery

Thin wall heat shrinkable tube, on spool or in lengths

Note: A standard spool may include sections which have been tied together. Other lengths available on request.

Type	L m	Inner-Ø inch before shrinking	Inner-Ø mm		Recovered wall thickness mm	Art.-No.	
			before shrinking	after shrinking			
<b>Spool   Colour: Black</b>							
SRC1	1.2-0.6	300	3/64	1.2	0.6	0.41	145102
	1.6-0.8	300	1/16	1.6	0.8	0.43	145103
	2.4-1.2	300	3/32	2.4	1.2	0.51	145104
	3.2-1.6	300	1/8	3.2	1.6	0.51	145105
	4.8-2.4	300	3/16	4.8	2.4	0.52	145106
	6.4-3.2	300	1/4	6.4	3.2	0.64	145107
	9.5-4.8	150	3/8	9.5	4.8	0.64	145108
	12.7-6.4	100	1/2	12.7	6.4	0.64	145111
	19.1-9.5	50	3/4	19.1	9.5	0.76	145115
	25.4-12.7	50	1	25.4	12.7	0.89	145116
38.1-19.1	50	1 1/2	38.1	19.1	1.02	145118	
51.0-25.4	50	2	51	25.4	1.14	145119	
<b>Lengths   Colour: Black</b>							
SRC1	1.2-0.6	1	3/64	1.2	0.6	0.41	145120
	1.6-0.8	1	1/16	1.6	0.8	0.43	145121
	2.4-1.2	1	3/32	2.4	1.2	0.51	145122
	3.2-1.6	1	1/8	3.2	1.6	0.51	145123
	4.8-2.4	1	3/16	4.8	2.4	0.52	145124
	6.4-3.2	1	1/4	6.4	3.2	0.64	145125
	9.5-4.8	1	3/8	9.5	4.8	0.64	145126
	12.7-6.4	1	1/2	12.7	6.4	0.64	145127
	19.1-9.5	1	3/4	19.1	9.5	0.76	145128
	25.4-12.7	1	1	25.4	12.7	0.89	145129
	38.1-19.1	1	1 1/2	38.1	19.1	1.02	145130
	51.0-25.4	1	2	51	25.4	1.14	145131

→ Continued on the next page



→ Continuation

**SRC1 Heat shrinkable thin wall tube**

Technical data	Value	Test standard
<b>Physical properties</b>		
Elongation at break	200 %	ASTM D 638
Tensile strength at break	10 MPa	ASTM D 638
Longitudinal shrinkage	≤ 10 %	ASTM D 2671
Shrink ratio	2:1	
<b>Thermal properties</b>		
Operating temperature range	-30 °C up to 105 °C	IEC 216
Shrinkage temperature	> 90 °C	CPT Test
Flexibility at low temperatures	-30 °C	ASTM-D 2671 C
<b>Electrical properties</b>		
Specific volume resistivity	10 <sup>14</sup> Ω x cm	ASTM D 257
<b>Chemical properties</b>		
Corrosion	None	ASTM D 2671 B
Resistance to fungus and decay	No growth	AMS-DTL-7444



## SR1F

### Heat shrinkable thin wall tube

self-extinguishing, shrink ratio 2 : 1, without adhesive

#### Characteristics

- Thin wall
- Inscrutable
- Resistant to chemical agents
- Stabilized against UV rays
- Free from paint-wetting inhibiting substances
- Non-corrosive
- Infusible
- High flexibility
- Superior electrical properties
- High tensile strength
- Resistant to cold flow (thermally stable)
- Self-extinguishing (except transparent)

#### Application/Suitability

- Insulating
- Bundling
- Marking
- Corrosion protection
- Mechanical protection

#### Material

- Cross-linked polyolefin
- Free of lead and cadmium

#### Test standards

- Approved according to UL File No.: E 172094
- Corresponds to MIL-I-23053/5 class 1

#### Storage conditions/Shelf life

- Unlimited shelf life



#### Colours

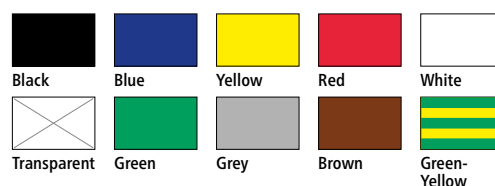

#### Scope of delivery

Thin wall heat shrinkable tube, on spool or in lengths

Note: A standard spool may include sections which have been tied together. Other lengths available on request.

Type	L m	Inner-Ø inch before shrinking	Inner-Ø mm		Recovered wall thickness mm	Art.-No.	
			before shrinking	after shrinking			
<b>Spool   Colour: Black</b>							
SR1F	1.6-0.8	300	1/16	1.6	0.8	0.43	126954
	2.4-1.2	300	3/32	2.4	1.2	0.51	126960
	3.2-1.6	300	1/8	3.2	1.6	0.51	126961
	4.8-2.4	300	3/16	4.8	2.4	0.52	126969
	6.4-3.2	300	1/4	6.4	3.2	0.64	126891
	9.5-4.8	150	3/8	9.5	4.8	0.64	126899
	12.7-6.4	100	1/2	12.7	6.4	0.64	126907
	19.1-9.5	50	3/4	19.1	9.5	0.76	126916
	25.4-12.7	50	1	25.4	12.7	0.89	126924
	38.1-19.1	50	1 1/2	38.1	19.1	1.02	126932
	51.0-25.4	50	2	51	25.4	1.14	126940
76.0-38.0	25	3	76	38	1.27	126945	
102.0-51.0	25	4	102	51	1.40	126950	
<b>Lengths   Colour: Black</b>							
SR1F	1.2-0.6	1.2	3/64	1.2	0.6	0.41	144322
	1.6-0.8	1.2	1/16	1.6	0.8	0.43	144328
	2.4-1.2	1.2	3/32	2.4	1.2	0.51	144334
	3.2-1.6	1.2	1/8	3.2	1.6	0.51	203008
	4.8-2.4	1.2	3/16	4.8	2.4	0.52	127189
	6.4-3.2	1.2	1/4	6.4	3.2	0.64	127190
	9.5-4.8	1.2	3/8	9.5	4.8	0.64	127191
	12.7-6.4	1.2	1/2	12.7	6.4	0.64	127192
	19.1-9.5	1.2	3/4	19.1	9.5	0.76	127193
	25.4-12.7	1.2	1	25.4	12.7	0.89	127194
	38.1-19.1	1.2	1 1/2	38.1	19.1	1.02	144288
	51.0-25.4	1.2	2	51	25.4	1.14	144300
	76.0-38.0	1.2	3	76	38	1.27	144308
102.0-51.0	1.2	4	102	51	1.40	144315	
<b>Lengths   Colour: Blue</b>							
SR1F	1.2-0.6	1.2	3/64	1.2	0.6	0.41	144324
	1.6-0.8	1.2	1/16	1.6	0.8	0.43	144330
	2.4-1.2	1.2	3/32	2.4	1.2	0.51	144336
	3.2-1.6	1.2	1/8	3.2	1.6	0.51	144345
	4.8-2.4	1.2	3/16	4.8	2.4	0.52	127201



Type	L m	Inner-Ø inch before shrinking	Inner-Ø mm		Recovered wall thickness mm	Art.-No.	
			before shrinking	after shrinking			
<b>(Continuation) Lengths   Colour: Blue</b>							
SR1F	6.4-3.2	1.2	1/4	6.4	3.2	0.64	127202
	9.5-4.8	1.2	3/8	9.5	4.8	0.64	127203
	12.7-6.4	1.2	1/2	12.7	6.4	0.64	127204
	19.1-9.5	1.2	3/4	19.1	9.5	0.76	127205
	25.4-12.7	1.2	1	25.4	12.7	0.89	127206
	38.1-19.1	1.2	1 1/2	38.1	19.1	1.02	144292
	51.0-25.4	1.2	2	51	25.4	1.14	144302
	76.0-38.0	1.2	3	76	38	1.27	144310
102.0-51.0	1.2	4	102	51	1.40	144317	
<b>Lengths   Colour: Yellow</b>							
SR1F	1.2-0.6	1.2	3/64	1.2	0.6	0.41	203911
	1.6-0.8	1.2	1/16	1.6	0.8	0.43	203913
	2.4-1.2	1.2	3/32	2.4	1.2	0.51	203919
	3.2-1.6	1.2	1/8	3.2	1.6	0.51	203923
	4.8-2.4	1.2	3/16	4.8	2.4	0.52	203927
	6.4-3.2	1.2	1/4	6.4	3.2	0.64	203931
	9.5-4.8	1.2	3/8	9.5	4.8	0.64	203935
	12.7-6.4	1.2	1/2	12.7	6.4	0.64	203915
	19.1-9.5	1.2	3/4	19.1	9.5	0.76	203917
	25.4-12.7	1.2	1	25.4	12.7	0.89	203921
	38.1-19.1	1.2	1 1/2	38.1	19.1	1.02	203925
	51.0-25.4	1.2	2	51	25.4	1.14	203929
102.0-51.0	1.2	4	102	51	1.40	203857	
<b>Lengths   Colour: Red</b>							
SR1F	1.2-0.6	1.2	3/64	1.2	0.6	0.41	144326
	1.6-0.8	1.2	1/16	1.6	0.8	0.43	144332
	2.4-1.2	1.2	3/32	2.4	1.2	0.51	144338
	3.2-1.6	1.2	1/8	3.2	1.6	0.51	144347
	4.8-2.4	1.2	3/16	4.8	2.4	0.52	127207
	6.4-3.2	1.2	1/4	6.4	3.2	0.64	127208
	9.5-4.8	1.2	3/8	9.5	4.8	0.64	127209
	12.7-6.4	1.2	1/2	12.7	6.4	0.64	127210
	19.1-9.5	1.2	3/4	19.1	9.5	0.76	127211
	25.4-12.7	1.2	1	25.4	12.7	0.89	127212
	38.1-19.1	1.2	1 1/2	38.1	19.1	1.02	144294
	51.0-25.4	1.2	2	51	25.4	1.14	144304
76.0-38.0	1.2	3	76	38	1.27	144312	
102.0-51.0	1.2	4	102	51	1.40	144319	
<b>Lengths   Colour: White</b>							
SR1F	1.2-0.6	1.2	3/64	1.2	0.6	0.41	144327
	1.6-0.8	1.2	1/16	1.6	0.8	0.43	144333
	2.4-1.2	1.2	3/32	2.4	1.2	0.51	144339
	3.2-1.6	1.2	1/8	3.2	1.6	0.51	144348
	4.8-2.4	1.2	3/16	4.8	2.4	0.52	127213
	6.4-3.2	1.2	1/4	6.4	3.2	0.64	127214
	9.5-4.8	1.2	3/8	9.5	4.8	0.64	127215
	12.7-6.4	1.2	1/2	12.7	6.4	0.64	127216
	19.1-9.5	1.2	3/4	19.1	9.5	0.76	127217
	25.4-12.7	1.2	1	25.4	12.7	0.89	127218
	38.1-19.1	1.2	1 1/2	38.1	19.1	1.02	144295
	51.0-25.4	1.2	2	51	25.4	1.14	144305
76.0-38.0	1.2	3	76	38	1.27	144313	
102.0-51.0	1.2	4	102	51	1.40	144320	
<b>Lengths   Colour: Transparent</b>							
SR1F	1.2-0.6	1.2	3/64	1.2	0.6	0.41	144323
	1.6-0.8	1.2	1/16	1.6	0.8	0.43	144329
	2.4-1.2	1.2	3/32	2.4	1.2	0.51	144335
	3.2-1.6	1.2	1/8	3.2	1.6	0.51	144344
	4.8-2.4	1.2	3/16	4.8	2.4	0.52	203267
	6.4-3.2	1.2	1/4	6.4	3.2	0.64	203270
	12.7-6.4	1.2	1/2	12.7	6.4	0.64	144255
	19.1-9.5	1.2	3/4	19.1	9.5	0.76	144267
	25.4-12.7	1.2	1	25.4	12.7	0.89	144279
	38.1-19.1	1.2	1 1/2	38.1	19.1	1.02	144291
	51.0-25.4	1.2	2	51	25.4	1.14	144301



# Heat shrinkable tubes

LOW VOLTAGE  
Heat shrink technology

Type	L m	Inner-Ø inch before shrinking	Inner-Ø mm		Recovered wall thickness mm	Art.-No.	
			before shrinking	after shrinking			
<b>(Continuation) Lengths   Colour: Transparent</b>							
SR1F	76.0-38.0	1.2	3	76	38	1.27	144309
	102.0-51.0	1.2	4	102	51	1.40	144316
<b>Lengths   Colour: Green</b>							
SR1F	1.2-0.6	1.2	3/64	1.2	0.6	0.41	203910
	1.6-0.8	1.2	1/16	1.6	0.8	0.43	203912
	2.4-1.2	1.2	3/32	2.4	1.2	0.51	203918
	3.2-1.6	1.2	1/8	3.2	1.6	0.51	203922
	4.8-2.4	1.2	3/16	4.8	2.4	0.52	203926
	6.4-3.2	1.2	1/4	6.4	3.2	0.64	203930
	9.5-4.8	1.2	3/8	9.5	4.8	0.64	203934
	12.7-6.4	1.2	1/2	12.7	6.4	0.64	203914
	19.1-9.5	1.2	3/4	19.1	9.5	0.76	203916
	25.4-12.7	1.2	1	25.4	12.7	0.89	203920
	38.1-19.1	1.2	1 1/2	38.1	19.1	1.02	203924
	51.0-25.4	1.2	2	51	25.4	1.14	203928
102.0-51.0	1.2	4	102	51	1.40	203856	
<b>Lengths   Colour: Grey</b>							
SR1F	1.2-0.6	1.2	3/64	1.2	0.6	0.41	203279
	1.6-0.8	1.2	1/16	1.6	0.8	0.43	203280
	2.4-1.2	1.2	3/32	2.4	1.2	0.51	203283
	3.2-1.6	1.2	1/8	3.2	1.6	0.51	144349
	4.8-2.4	1.2	3/16	4.8	2.4	0.52	203266
	6.4-3.2	1.2	1/4	6.4	3.2	0.64	203269
	9.5-4.8	1.2	3/8	9.5	4.8	0.64	203272
	12.7-6.4	1.2	1/2	12.7	6.4	0.64	144262
	19.1-9.5	1.2	3/4	19.1	9.5	0.76	203274
	25.4-12.7	1.2	1	25.4	12.7	0.89	144286
	38.1-19.1	1.2	1 1/2	38.1	19.1	1.02	144298
	51.0-25.4	1.2	2	51	25.4	1.14	203284
	76.0-38.0	1.2	3	76	38	1.27	203285
	102.0-51.0	1.2	4	102	51	1.40	203282
<b>Lengths   Colour: Brown</b>							
SR1F	1.2-0.6	1.2	3/64	1.2	0.6	0.41	203278
	1.6-0.8	1.2	1/16	1.6	0.8	0.43	201541
	2.4-1.2	1.2	3/32	2.4	1.2	0.51	144340
	3.2-1.6	1.2	1/8	3.2	1.6	0.51	144350
	4.8-2.4	1.2	3/16	4.8	2.4	0.52	203265
	6.4-3.2	1.2	1/4	6.4	3.2	0.64	203268
	9.5-4.8	1.2	3/8	9.5	4.8	0.64	203271
	12.7-6.4	1.2	1/2	12.7	6.4	0.64	144263
	19.1-9.5	1.2	3/4	19.1	9.5	0.76	144275
	25.4-12.7	1.2	1	25.4	12.7	0.89	144287
	38.1-19.1	1.2	1 1/2	38.1	19.1	1.02	144299
	76.0-38.0	1.2	3	76	38	1.27	169180
	102.0-51.0	1.2	4	102	51	1.40	203281
	<b>Lengths   Colour: Green-Yellow</b>						
SR1F	1.2-0.6	1.2	3/64	1.2	0.6	0.41	198530
	1.6-0.8	1.2	1/16	1.6	0.8	0.43	198519
	2.4-1.2	1.2	3/32	2.4	1.2	0.51	198518
	3.2-1.6	1.2	1/8	3.2	1.6	0.51	144343
	4.8-2.4	1.2	3/16	4.8	2.4	0.52	127225
	6.4-3.2	1.2	1/4	6.4	3.2	0.64	127226
	9.5-4.8	1.2	3/8	9.5	4.8	0.64	127227
	12.7-6.4	1.2	1/2	12.7	6.4	0.64	127228
	19.1-9.5	1.2	3/4	19.1	9.5	0.76	127229
	25.4-12.7	1.2	1	25.4	12.7	0.89	127230
	38.1-19.1	1.2	1 1/2	38.1	19.1	1.02	144290
	51.0-25.4	1.2	2	51	25.4	1.14	203889

→ Continued on the next page





→ Continuation

**SR1F Heat shrinkable thin wall tube**

Technical data	Value	Test standard
<b>Physical properties</b>		
Elongation at break	350 %	ASTM D 638
Tensile strength at break	13 MPa	ASTM D 638
Longitudinal shrinkage	≤ 10 %	ASTM D 2671
Shrink ratio	2:1	IEC 811-1-1
<b>Thermal properties</b>		
Operating temperature range	-55 °C up to 135 °C	IEC 216
Shrinkage temperature	> 90 °C	CPT Test
Burning behaviour	self-extinguishing	UL 224
Flexibility at low temperatures	-55 °C	ASTM-D 2671 C
<b>Electrical properties</b>		
Dielectric strength	20 kV/mm	ASTM D 2671
Specific volume resistivity	10 <sup>14</sup> Ω x cm	ASTM D 257
<b>Chemical properties</b>		
Corrosion	None	ASTM D 2671 B
Resistance to fungus and decay	No growth	AMS-DTL-7444

**SR1F3****Heat shrinkable thin wall tube**

self-extinguishing, shrink ratio 3 : 1, without adhesive

**Characteristics**

- Thin wall
- Inscrutable
- Resistant to chemical agents
- Stabilized against UV rays
- Free from paint-wetting inhibiting substances
- Non-corrosive
- Infusible
- High flexibility
- Superior electrical properties
- High tensile strength
- Resistant to cold flow (thermally stable)
- Self-extinguishing (except transparent)

**Application/Suitability**

- Insulating
- Bundling
- Marking
- Corrosion protection
- Mechanical protection

**Material**

- Cross-linked polyolefin
- Free of lead and cadmium

**Test standards**

- Approved according to UL File No.: E 172094
- Corresponds to MIL-I-23053/5 class 1

**Storage conditions/Shelf life**

- Unlimited shelf life

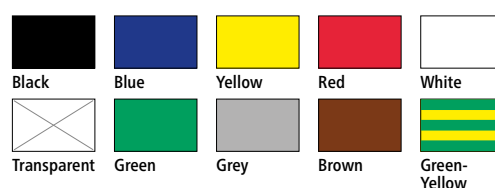
**Colours****Scope of delivery**

Thin wall heat shrinkable tube, on spool or in lengths

Note: A standard spool may include sections which have been tied together.  
Other lengths available on request.

Type	L m	Inner-Ø mm		Recovered wall thickness mm	Art.-No.	
		before shrinking	after shrinking			
<b>Spool   Colour: Black</b>						
SR1F3	1.5-0.5	300	1.5	0.5	0.45	126977
	3.0-1.0	300	3	1	0.55	127242
	6.0-2.0	300	6	2	0.65	126990
	9.0-3.0	150	9	3	0.75	126995
	12.0-4.0	100	12	4	0.75	127000
	18.0-6.0	50	18	6	0.75	127005
	24.0-8.0	50	24	8	1.00	127010
	39.0-13.0	30	39	13	1.15	127015
<b>Lengths   Colour: Black</b>						
SR1F3	1.5-0.5	1	1.5	0.5	0.45	144362
	3.0-1.0	1	3	1	0.55	144368
	6.0-2.0	1	6	2	0.65	144378
	9.0-3.0	1	9	3	0.75	144385
	12.0-4.0	1	12	4	0.75	144392
	18.0-6.0	1	18	6	0.75	144399
	24.0-8.0	1	24	8	1.00	144406
	39.0-13.0	1	39	13	1.15	144413
<b>Lengths   Colour: Blue</b>						
SR1F3	3.0-1.0	1	3	1	0.55	144371
	6.0-2.0	1	6	2	0.65	144381
	9.0-3.0	1	9	3	0.75	144388
	12.0-4.0	1	12	4	0.75	144395
	18.0-6.0	1	18	6	0.75	144401
	24.0-8.0	1	24	8	1.00	144408
	39.0-13.0	1	39	13	1.15	144415
<b>Lengths   Colour: Yellow</b>						
SR1F3	3.0-1.0	1	3	1	0.55	144372
	6.0-2.0	1	6	2	0.65	144382
	9.0-3.0	1	9	3	0.75	144389
	12.0-4.0	1	12	4	0.75	144396
	18.0-6.0	1	18	6	0.75	144402
	24.0-8.0	1	24	8	1.00	144409
39.0-13.0	1	39	13	1.15	144416	



Type	L m	Inner-Ø mm		Recovered wall thickness mm	Art.-No.
		before shrinking	after shrinking		
<b>(Continuation) Lengths   Colour: Red</b>					
SR1F3	1.5-0.5	1	1.5	0.5	144366
	3.0-1.0	1	3	1	144374
	6.0-2.0	1	6	2	144383
	9.0-3.0	1	9	3	144390
	12.0-4.0	1	12	4	144397
	18.0-6.0	1	18	6	144403
	24.0-8.0	1	24	8	144410
	39.0-13.0	1	39	13	144417
<b>Lengths   Colour: White</b>					
SR1F3	1.5-0.5	1	1.5	0.5	144367
	3.0-1.0	1	3	1	144375
	6.0-2.0	1	6	2	144384
	9.0-3.0	1	9	3	144391
	12.0-4.0	1	12	4	144398
	18.0-6.0	1	18	6	144404
	24.0-8.0	1	24	8	144411
	39.0-13.0	1	39	13	144418
<b>Lengths   Colour: Transparent</b>					
SR1F3	1.5-0.5	1	1.5	0.5	144363
	3.0-1.0	1	3	1	144369
	6.0-2.0	1	6	2	144379
	9.0-3.0	1	9	3	144386
	12.0-4.0	1	12	4	144393
	18.0-6.0	1	18	6	144400
	24.0-8.0	1	24	8	144407
	39.0-13.0	1	39	13	144414
<b>Lengths   Colour: Green</b>					
SR1F3	1.5-0.5	1	1.5	0.5	204010
	3.0-1.0	1	3	1	204014
	6.0-2.0	1	6	2	154613
	9.0-3.0	1	9	3	204021
	12.0-4.0	1	12	4	204025
	18.0-6.0	1	18	6	144405
	24.0-8.0	1	24	8	204031
	39.0-13.0	1	39	13	144419
<b>Lengths   Colour: Grey</b>					
SR1F3	1.5-0.5	1	1.5	0.5	204008
	3.0-1.0	1	3	1	204012
	6.0-2.0	1	6	2	204016
	9.0-3.0	1	9	3	204019
	12.0-4.0	1	12	4	204023
	18.0-6.0	1	18	6	204027
	24.0-8.0	1	24	8	204030
	39.0-13.0	1	39	13	204033
<b>Lengths   Colour: Brown</b>					
SR1F3	3.0-1.0	1	3	1	204013
	6.0-2.0	1	6	2	204017
	9.0-3.0	1	9	3	204020
	12.0-4.0	1	12	4	204024
	18.0-6.0	1	18	6	204028
	24.0-8.0	1	24	8	144412
	39.0-13.0	1	39	13	204034
<b>Lengths   Colour: Green-Yellow</b>					
SR1F3	1.5-0.5	1	1.5	0.5	204011
	3.0-1.0	1	3	1	204015
	6.0-2.0	1	6	2	204018
	9.0-3.0	1	9	3	204022
	12.0-4.0	1	12	4	204026
	18.0-6.0	1	18	6	204029
	24.0-8.0	1	24	8	204032
	39.0-13.0	1	39	13	204035

→ Continued on the next page



→ Continuation

**SR1F3** Heat shrinkable thin wall tube

Technical data	Value	Test standard
<b>Physical properties</b>		
Elongation at break	300 %	ASTM D 638
Tensile strength at break	13 MPa	ASTM D 638
Longitudinal shrinkage	≤ 10 %	ASTM D 2671
Shrink ratio	3:1	IEC 811-1-1
<b>Thermal properties</b>		
Operating temperature range	-55 °C up to 135 °C	IEC 216
Shrinkage temperature	> 90 °C	CPT Test
Burning behaviour	self-extinguishing	UL 224
Flexibility at low temperatures	-55 °C	ASTM-D 2671 C
<b>Electrical properties</b>		
Dielectric strength	20 kV/mm	ASTM D 2671
Specific volume resistivity	10 <sup>14</sup> Ω x cm	ASTM D 257
<b>Chemical properties</b>		
Corrosion	None	ASTM D 2671 B
Resistance to fungus and decay	No growth	AMS-DTL-7444



## SB

### Heat shrinkable tube in dispenser box

thin wall, self-extinguishing, shrink ratio 2 : 1, without adhesive

#### Characteristics

- Back-winding mechanism facilitates rolling up of tube
- User friendly, notch prevents tube from rolling back into the box

#### Note

- Self-extinguishing (except transparent)
- See „SR1F“ heat shrinkable tube for further information on product properties and technical data

#### Application/Suitability

- Insulating
- Bundling
- Marking
- Corrosion protection
- Mechanical protection

#### Material

- Cross-linked polyolefin
- Free of lead and cadmium

#### Test standards

- Approved according to UL File No.: E 172094
- Corresponds to MIL-I-23053/5 class 1

#### Storage conditions/Shelf life

- Unlimited shelf life



#### Colours

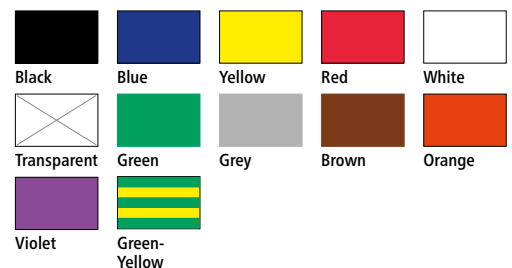

#### Scope of delivery

Thin wall heat shrinkable tube in dispenser box

Note: A standard spool may include sections which have been tied together.

Type	L m	Inner-Ø inch before shrinking	Inner-Ø mm		Recovered wall thickness mm	Art.-No.
			before shrinking	after shrinking		
<b>Colour: Black</b>						
SB	1.2-0.6	15	3/64	1.2	0.6	127020
	1.6-0.8	15	1/16	1.6	0.8	127027
	2.4-1.2	15	3/32	2.4	1.2	127034
	3.2-1.6	15	1/8	3.2	1.6	127041
	4.8-2.4	10	3/16	4.8	2.4	127049
	6.4-3.2	10	1/4	6.4	3.2	127057
	9.5-4.8	10	3/8	9.5	4.8	127065
	12.7-6.4	8	1/2	12.7	6.4	127073
19.1-9.5	7	3/4	19.1	9.5	127081	
25.4-12.7	4	1	25.4	12.7	127089	
<b>Colour: Blue</b>						
SB	3.2-1.6	15	1/8	3.2	1.6	127044
	4.8-2.4	10	3/16	4.8	2.4	127052
	6.4-3.2	10	1/4	6.4	3.2	127060
	9.5-4.8	10	3/8	9.5	4.8	127068
	12.7-6.4	8	1/2	12.7	6.4	127076
	19.1-9.5	7	3/4	19.1	9.5	127084
	25.4-12.7	4	1	25.4	12.7	127092
<b>Colour: Yellow</b>						
SB	3.2-1.6	15	1/8	3.2	1.6	127045
	4.8-2.4	10	3/16	4.8	2.4	127053
	6.4-3.2	10	1/4	6.4	3.2	127061
	9.5-4.8	10	3/8	9.5	4.8	127069
	12.7-6.4	8	1/2	12.7	6.4	127077
	19.1-9.5	7	3/4	19.1	9.5	127085
	25.4-12.7	4	1	25.4	12.7	127093
<b>Colour: Red</b>						
SB	3.2-1.6	15	1/8	3.2	1.6	127046
	4.8-2.4	10	3/16	4.8	2.4	127054
	6.4-3.2	10	1/4	6.4	3.2	127062
	9.5-4.8	10	3/8	9.5	4.8	127070
	12.7-6.4	8	1/2	12.7	6.4	127078
	19.1-9.5	7	3/4	19.1	9.5	127086
	25.4-12.7	4	1	25.4	12.7	127094



# Heat shrinkable tubes

LOW VOLTAGE  
Heat shrink technology

Type	L m	Inner-Ø inch before shrinking	Inner-Ø mm		Recovered wall thickness mm	Art.-No.	
			before shrinking	after shrinking			
<b>(Continuation) Colour: White</b>							
SB	3.2-1.6	15	1/8	3.2	1.6	0.51	127047
	4.8-2.4	10	3/16	4.8	2.4	0.51	127055
	6.4-3.2	10	1/4	6.4	3.2	0.64	127063
	9.5-4.8	10	3/8	9.5	4.8	0.64	127071
	12.7-6.4	8	1/2	12.7	6.4	0.64	127079
	19.1-9.5	7	3/4	19.1	9.5	0.76	127087
	25.4-12.7	4	1	25.4	12.7	0.89	127095
<b>Colour: Transparent</b>							
SB	1.2-0.6	15	3/64	1.2	0.6	0.41	127021
	3.2-1.6	15	1/8	3.2	1.6	0.51	127043
	4.8-2.4	10	3/16	4.8	2.4	0.51	127051
	6.4-3.2	10	1/4	6.4	3.2	0.64	127059
	9.5-4.8	10	3/8	9.5	4.8	0.64	127067
	12.7-6.4	8	1/2	12.7	6.4	0.64	127075
	19.1-9.5	7	3/4	19.1	9.5	0.76	127083
25.4-12.7	4	1	25.4	12.7	0.89	127091	
<b>Colour: Green</b>							
SB	3.2-1.6	15	1/8	3.2	1.6	0.51	127048
	4.8-2.4	10	3/16	4.8	2.4	0.51	127056
	6.4-3.2	10	1/4	6.4	3.2	0.64	127064
	9.5-4.8	10	3/8	9.5	4.8	0.64	127072
	12.7-6.4	8	1/2	12.7	6.4	0.64	127080
	19.1-9.5	7	3/4	19.1	9.5	0.76	127088
	25.4-12.7	4	1	25.4	12.7	0.89	127096
<b>Colour: Grey</b>							
SB	3.2-1.6	15	1/8	3.2	1.6	0.51	144429
	4.8-2.4	10	3/16	4.8	2.4	0.51	144433
	6.4-3.2	10	1/4	6.4	3.2	0.64	144438
	9.5-4.8	10	3/8	9.5	4.8	0.64	144444
	12.7-6.4	8	1/2	12.7	6.4	0.64	144449
	19.1-9.5	7	3/4	19.1	9.5	0.76	144455
	25.4-12.7	4	1	25.4	12.7	0.89	144460
<b>Colour: Brown</b>							
SB	3.2-1.6	15	1/8	3.2	1.6	0.51	144430
	4.8-2.4	10	3/16	4.8	2.4	0.51	144434
	6.4-3.2	10	1/4	6.4	3.2	0.64	144439
	9.5-4.8	10	3/8	9.5	4.8	0.64	144445
	12.7-6.4	8	1/2	12.7	6.4	0.64	144450
	19.1-9.5	7	3/4	19.1	9.5	0.76	144456
	25.4-12.7	4	1	25.4	12.7	0.89	144461
<b>Colour: Orange</b>							
SB	3.2-1.6	15	1/8	3.2	1.6	0.51	144426
	4.8-2.4	10	3/16	4.8	2.4	0.51	144431
	6.4-3.2	10	1/4	6.4	3.2	0.64	144435
	9.5-4.8	10	3/8	9.5	4.8	0.64	144440
	12.7-6.4	8	1/2	12.7	6.4	0.64	144446
	19.1-9.5	7	3/4	19.1	9.5	0.76	144451
	25.4-12.7	4	1	25.4	12.7	0.89	144457
<b>Colour: Violet</b>							
SB	3.2-1.6	15	1/8	3.2	1.6	0.51	144428
	6.4-3.2	10	1/4	6.4	3.2	0.64	144437
	9.5-4.8	10	3/8	9.5	4.8	0.64	144443
	12.7-6.4	8	1/2	12.7	6.4	0.64	144448
	19.1-9.5	7	3/4	19.1	9.5	0.76	144454
	25.4-12.7	4	1	25.4	12.7	0.89	144459
<b>Colour: Green-Yellow</b>							
SB	3.2-1.6	15	1/8	3.2	1.6	0.51	127042
	4.8-2.4	10	3/16	4.8	2.4	0.51	127050
	6.4-3.2	10	1/4	6.4	3.2	0.64	127058
	9.5-4.8	10	3/8	9.5	4.8	0.64	127066
	12.7-6.4	8	1/2	12.7	6.4	0.64	127074
	19.1-9.5	7	3/4	19.1	9.5	0.76	127082
	25.4-12.7	4	1	25.4	12.7	0.89	127090



## SB

### Heat shrinkable tube in dispenser box

thin wall, self-extinguishing, shrink ratio 3 : 1, without adhesive

#### Characteristics

- Back-winding mechanism facilitates rolling up of tube
- User friendly, notch prevents tube from rolling back into the box

#### Note

- Self-extinguishing (except transparent)
- See „SR1F3“ heat shrinkable tube for further information on product properties and technical data

#### Application/Suitability

- Insulating
- Bundling
- Marking
- Corrosion protection
- Mechanical protection

#### Material

- Cross-linked polyolefin
- Free of lead and cadmium

#### Test standards

- Approved according to UL File No.: E 172094
- Corresponds to MIL-I-23053/5 class 1

#### Storage conditions/Shelf life

- Unlimited shelf life



#### Colours

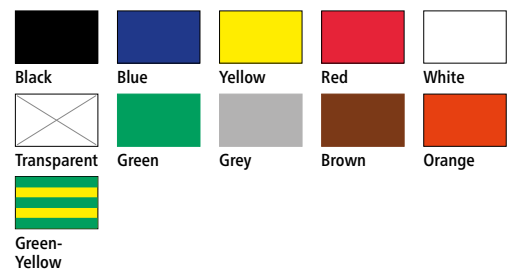

#### Scope of delivery

Thin wall heat shrinkable tube in dispenser box

Note: A standard spool may include sections which have been tied together.

Type	L m	Inner-Ø mm		Recovered wall thickness mm	Art.-No.
		before shrinking	after shrinking		
<b>Colour: Black</b>					
SB	1.5-0.5	15	1.5	0.5	127097
	3.0-1.0	15	3	1	127104
	6.0-2.0	10	6	2	127111
	9.0-3.0	10	9	3	127118
	12.0-4.0	8	12	4	127125
	18.0-6.0	7	18	6	127132
	24.0-8.0	4	24	8	127139
<b>Colour: Blue</b>					
SB	1.5-0.5	15	1.5	0.5	127099
	3.0-1.0	15	3	1	127106
	6.0-2.0	10	6	2	127113
	9.0-3.0	10	9	3	127120
	12.0-4.0	8	12	4	127127
	18.0-6.0	7	18	6	127134
	24.0-8.0	4	24	8	127141
<b>Colour: Yellow</b>					
SB	1.5-0.5	15	1.5	0.5	127100
	3.0-1.0	15	3	1	127107
	6.0-2.0	10	6	2	127114
	9.0-3.0	10	9	3	127121
	12.0-4.0	8	12	4	127128
	18.0-6.0	7	18	6	127135
	24.0-8.0	4	24	8	127142
<b>Colour: Red</b>					
SB	1.5-0.5	15	1.5	0.5	127101
	3.0-1.0	15	3	1	127108
	6.0-2.0	10	6	2	127115
	9.0-3.0	10	9	3	127122
	12.0-4.0	8	12	4	127129
	18.0-6.0	7	18	6	127136
	24.0-8.0	4	24	8	127143



# Heat shrinkable tubes

LOW VOLTAGE  
Heat shrink technology

Type	L m	Inner-Ø mm		Recovered wall thickness mm	Art.-No.
		before shrinking	after shrinking		
<b>(Continuation) Colour: White</b>					
SB	1.5-0.5	15	1.5	0.5	127102
	3.0-1.0	15	3	1	127109
	6.0-2.0	10	6	2	127116
	9.0-3.0	10	9	3	127123
	12.0-4.0	8	12	4	127130
	18.0-6.0	7	18	6	127137
	24.0-8.0	4	24	8	127144
<b>Colour: Transparent</b>					
SB	1.5-0.5	15	1.5	0.5	127098
	3.0-1.0	15	3	1	144462
	6.0-2.0	10	6	2	127112
	9.0-3.0	10	9	3	127119
	12.0-4.0	8	12	4	127126
	18.0-6.0	7	18	6	127133
	24.0-8.0	4	24	8	127140
<b>Colour: Green</b>					
SB	1.5-0.5	15	1.5	0.5	200294
	3.0-1.0	15	3	1	127110
	6.0-2.0	10	6	2	127117
	9.0-3.0	10	9	3	200295
	12.0-4.0	8	12	4	127131
	18.0-6.0	7	18	6	127138
	24.0-8.0	4	24	8	127145
<b>Colour: Grey</b>					
SB	1.5-0.5	15	1.5	0.5	203674
	3.0-1.0	15	3	1	203675
	6.0-2.0	10	6	2	203676
	9.0-3.0	10	9	3	203677
	12.0-4.0	8	12	4	203678
	18.0-6.0	7	18	6	203679
	24.0-8.0	4	24	8	203680
<b>Colour: Brown</b>					
SB	3.0-1.0	15	3	1	203787
	6.0-2.0	10	6	2	203788
	9.0-3.0	10	9	3	203789
	12.0-4.0	8	12	4	203790
	18.0-6.0	7	18	6	203791
	24.0-8.0	4	24	8	203792
<b>Colour: Orange</b>					
SB	12.0-4.0	8	12	4	144464
<b>Colour: Green-Yellow</b>					
SB	1.5-0.5	15	1.5	0.5	204297
	3.0-1.0	15	3	1	204298
	6.0-2.0	10	6	2	204299
	9.0-3.0	10	9	3	204310
	12.0-4.0	8	12	4	204311
	18.0-6.0	7	18	6	204312
	24.0-8.0	4	24	8	204313





## SBS

### Heat shrinkable tube in dispenser box

thin wall, self-extinguishing, shrink ratio 2 : 1, without adhesive

#### Characteristics

- Back-winding mechanism facilitates rolling up of tube
- User friendly, notch prevents tube from rolling back into the box

#### Note

- Self-extinguishing (except transparent)
- See „SR1F“ heat shrinkable tube for further information on product properties and technical data

#### Application/Suitability

- Insulating
- Bundling
- Marking
- Corrosion protection
- Mechanical protection

#### Material

- Cross-linked polyolefin
- Free of lead and cadmium

#### Test standards

- Approved according to UL File No.: E 172094
- Corresponds to MIL-I-23053/5 class 1

#### Storage conditions/Shelf life

- Unlimited shelf life



#### Colours



Black

#### Scope of delivery

Thin wall heat shrinkable tube in dispenser box

Note: A standard spool may include sections which have been tied together.

Type	L m	Inner-Ø inch before shrinking	Inner-Ø mm		Recovered wall thickness mm	Art.-No.	
			before shrinking	after shrinking			
Colour: Black							
SBS	1.2-0.6	10	3/64	1.2	0.6	0.41	145132
	1.6-0.8	10	1/16	1.6	0.8	0.43	145135
	2.4-1.2	10	3/32	2.4	1.2	0.51	145137
	3.2-1.6	10	1/8	3.2	1.6	0.52	145142
	4.8-2.4	10	3/16	4.8	2.4	0.52	145150
	6.4-3.2	5	1/4	6.4	3.2	0.64	145157
	9.5-4.8	5	3/8	9.5	4.8	0.64	145165
	12.7-6.4	5	1/2	12.7	6.4	0.64	145173
	19.1-9.5	5	3/4	19.1	9.5	0.76	145181
	25.4-12.7	3	1	25.4	12.7	0.89	145189



## MBS

### Assortment box

with thin wall heat shrinkable tubes and cable ties

#### Characteristics

- Practice-oriented product assortment

#### Note

- See „SR1F“ and „SRC1“ heat shrinkable tubes and „KS“ cable ties for further information on product properties and technical data

#### Application/Suitability

- For marking and insulation of cables and conductors
- Corrosion protection
- Mechanical protection

#### Test standards

- Approved according to UL File No.: E 172094
- Corresponds to MIL-I-23053/5 class 1

#### Storage conditions/Shelf life

- Unlimited shelf life



#### Scope of delivery

Assortment box, cable ties, heat shrinkable tubes in various dimensions, lengths and colours

Heat shrinkable tubes				
SR1F	1.6-0.8	Red	30 mm	50 pieces
	2.4-1.2	Red	50 mm	10 pieces
	3.2-1.6	Yellow	30 mm	30 pieces
	3.2-1.6	Transparent	50 mm	40 pieces
	4.8-2.4	Yellow	100 mm	10 pieces
	4.8-2.4	Transparent	100 mm	10 pieces
	4.8-2.4	Blue	50 mm	25 pieces
	4.8-2.4	Red	50 mm	25 pieces
	6.4-3.2	Red	100 mm	10 pieces
	6.4-3.2	Blue	100 mm	10 pieces
	6.4-3.2	White	50 mm	10 pieces
	6.4-3.2	Transparent	50 mm	10 pieces
SRC1	2.4-1.2	Black	50 mm	30 pieces
	9.5-4.8	Black	50 mm	10 pieces
	12.7-6.4	Black	100 mm	5 pieces
	12.7-6.4	Black	150 mm	5 pieces
	19.1-9.5	Black	100 mm	5 pieces
	19.1-9.5	Black	200 mm	5 pieces
	25.4-12.7	Black	250 mm	3 pieces
Cable ties				
KS	3.6-140	Black	140 mm	100 pieces

Type	Art.-No.
MBS1	144420



## MMK Mini joint case

with medium wall heat shrinkable tubes and heat shrinkable crimp connectors, for joints up to 2.5 mm<sup>2</sup>

### Characteristics

- Practical multi-purpose case with adjustable compartments, containing heat shrinkable tubes and heat shrinkable crimp connectors

### Application/Suitability

- Fast-assembly kit for up to 16 straight-through joints ranging between 0.5 and 2.5 mm<sup>2</sup>

### Note

- See „SRUM“ heat shrinkable tube and „DR“ heat shrinkable crimp connectors for further information on product properties and technical data



### Scope of delivery

Multi-purpose case, heat shrinkable tubes and heat shrinkable crimp connectors in various dimensions, lengths and colours

Heat shrinkable tubes				
SRUM	19-6	Black	160 mm	10 pieces
	24-8	Black	160 mm	6 pieces
Heat shrinkable crimp connectors				
DR	1	Red		20 pieces
	2	Blue		30 pieces

Type	Art.-No.
MMK	193442

**SRUM****Heat shrinkable medium wall tube**

self-extinguishing, flexible, shrink ratio 3 : 1 or 4 : 1, with adhesive

**Characteristics**

- Medium wall
- Inscrutable
- Resistant to chemical agents
- Stabilized against UV rays
- Free from paint-wetting inhibiting substances
- Non-corrosive
- Infusible
- High flexibility
- Superior electrical properties
- High tensile strength
- Resistant to cold flow (thermally stable)
- Self-extinguishing

**Application/Suitability**

- Insulating
- Bundling
- Corrosion protection
- Mechanical protection

**Material**

- Cross-linked polyolefin
- Free of lead and cadmium

**Test standards**

- Corresponds to MIL-I-23053/4

**Storage conditions/Shelf life**

- Unlimited shelf life

**Colours**

Black

**Scope of delivery**

Medium wall heat shrinkable tube, on spool or in lengths

Note: A standard spool may include sections which have been tied together.  
Other lengths available on request.

Type	L m	Inner-Ø mm		Recovered wall thickness mm	Art.-No.	
		before shrinking	after shrinking			
<b>Shrink ratio 3:1</b>						
<b>Spool   Colour: Black</b>						
SRUM	3-1	300	3	1	1.4	127471
	6-2	300	6	2	1.7	127472
	9-3	150	9	3	1.9	127473
	12-4	100	12	4	2.3	127474
	19-6	50	19	6	2.7	127475
	24-8	50	24	8	3.1	127476
	40-13	30	40	13	3.1	127477
<b>Lengths   Colour: Black</b>						
SRUM	3-1	1	3	1	1.4	148840
	6-2	1	6	2	1.7	149433
	9-3	1	9	3	1.9	152008
	12-4	1	12	4	2.3	148842
	19-6	1	19	6	2.7	150148
	24-8	1	24	8	3.1	150278
	40-13	1	40	13	3.1	150149
<b>Shrink ratio 4:1</b>						
<b>Spool   Colour: Black</b>						
SRUM	4-1	300	4	1	1.4	145064
	8-2	150	8	2	1.7	145065
	16-4	100	16	4	2.3	145069
	24-6	50	24	6	2.7	145071
	32-8	30	32	8	3.1	145073
	52-13	30	52	13	3.1	145075
<b>Lengths   Colour: Black</b>						
SRUM	4-1	1	4	1	1.4	240160
	8-2	1	8	2	1.7	240163
	16-4	1	16	4	2.3	240167
	24-6	1	24	6	2.7	240168
	32-8	1	32	8	3.1	240170
	52-13	1	52	13	3.1	155962

→ Continued on the next page



→ Continuation

**SRUM Heat shrinkable medium wall tube**

Technical data	Value	Test standard
<b>Physical properties</b>		
Elongation at break	300 %	ASTM D 638
Tensile strength at break	11 MPa	ASTM D 638
Longitudinal shrinkage	≤ 15 %	ASTM D 2671
<b>Thermal properties</b>		
Operating temperature range	-55 °C up to 110 °C	IEC 216
Shrinkage temperature	> 110 °C	
Burning behaviour	self-extinguishing	UL 224
Flexibility at low temperatures	-55 °C up to + 110 °C	ASTM-D 2671 C
<b>Electrical properties</b>		
Dielectric strength	15 kV/mm	ASTM D 2671
Specific volume resistivity	10 <sup>14</sup> Ω x cm	ASTM D 257
<b>Chemical properties</b>		
Corrosion	None	ASTM D 2671 B
Resistance to fungus and decay	No growth	AMS-DTL-7444



## SR2, SRH2

### Heat shrinkable medium wall tube

halogen-free, shrink ratio 3 : 1, with or without adhesive

#### Characteristics

- Medium wall
- Inscrutable
- Resistant to chemical agents
- Stabilized against UV rays
- Free from paint-wetting inhibiting substances
- Halogen-free
- Non-corrosive
- Infusible
- Superior electrical properties
- High tensile strength
- Resistant to cold flow (thermally stable)

#### Application/Suitability

- Insulating
- Protection against moisture and pressure
- Suitable for heat shrinkable joints and terminations

#### Material

- Cross-linked polyolefin
- Free of lead and cadmium

#### Test standards

- Corresponds to IEC 60684-2

#### Storage conditions/Shelf life

- Unlimited shelf life



#### Colours



Black



Green-Yellow

#### Scope of delivery

Medium wall heat shrinkable tube, on spool or in lengths

Note: A standard spool may include sections which have been tied together. Other lengths available on request.

Type	L m	Inner-Ø mm		Recovered wall thickness mm	Art.-No.	
		before shrinking	after shrinking			
<b>without adhesive</b>						
<b>Spool   Colour: Black</b>						
SR2	12-3	30	12	3	2.2	143759
	22-6	30	22	6	2.6	143764
	34-7	30	34	7	2.6	143766
	40-12	30	40	12	2.6	143770
	56-16	30	56	16	2.7	143803
<b>Spool   Colour: Green-Yellow</b>						
SR2	12-4	5	12	4	1.5	127383
	12-4	25	12	4	1.5	127384
	27-9	5	27	9	1.5	127386
	27-9	25	27	9	1.5	127387
<b>Lengths   Colour: Black</b>						
SR2	12-3	1	12	3	2.2	127391
	22-6	1	22	6	2.6	127394
	34-7	1	34	7	2.6	127397
	40-12	1	40	12	2.6	127400
	56-16	1	56	16	2.7	127403
	63-19	1	63	19	2.8	143818
	75-22	1	75	22	3	127406
	95-26	1	95	26	3.2	127407
	120-34	1	120	34	3.3	127408
	140-42	1	140	42	3.5	143806
	160-50	1	160	50	3.5	143811
<b>with adhesive</b>						
<b>Lengths   Colour: Black</b>						
SRH2	8-2	1	8	2	1.7	127416
	12-3	1	12	3	2.2	127417
	22-6	1	22	6	2.6	127418
	34-7	1	34	7	2.6	127421
	40-12	1	40	12	2.6	127423
	56-16	1	56	16	2.7	127425
	63-19	1	63	19	2.8	135859
	75-22	1	75	22	3	127427
	95-26	1	95	26	3.2	127429
	120-34	1	120	34	3.3	127431
	140-42	1	140	42	3.5	144013
	160-50	1	160	50	3.5	144018



→ Continuation

**SR2, SRH2 Heat shrinkable medium wall tube**

Technical data	Value	Test standard
<b>Physical properties</b>		
Hardness	55 Shore D	DIN 53 505
Elongation at break	350 %	IEC 60684-2
Tensile strength at break	13 MPa	IEC 60684-2
Longitudinal shrinkage	≤ 10 %	IEC 60684-2
Shrink ratio	3:1	IEC 60684-2
Eccentricity expanded	50 %	IEC 60684-2
recovered	85 %	
<b>Thermal properties</b>		
Operating temperature range	-40 °C up to 120 °C	IEC 60684-2
Shrinkage temperature	> 125 °C	
Burning behaviour	not self-extinguishing	IEC 60684-2 method C
Flexibility at low temperatures	-40 °C	IEC 60684-2
Thermal ageing (168 h at 150 °C)		
Elongation at break	250 %	IEC 60684-2
Tensile strength at break	12 MPa	
<b>Electrical properties</b>		
Dielectric strength	25 kV/mm	IEC 60684-2
Specific volume resistivity	10 <sup>14</sup> Ω x cm	IEC 60684-2
<b>Chemical properties</b>		
Corrosion	None	IEC 60684-2
Resistance to fungus and decay	Rate 1	IEC 60684-2

**SRFH2****Heat shrinkable medium wall tube**

self-extinguishing, shrink ratio 3 : 1, with adhesive

**Characteristics**

- Medium wall
- Inscrutable
- Resistant to chemical agents
- Stabilized against UV rays
- Free from paint-wetting inhibiting substances
- Non-corrosive
- Infusible
- Superior electrical properties
- High tensile strength
- Resistant to cold flow (thermally stable)
- Self-extinguishing

**Application/Suitability**

- Insulating
- Protection against moisture and pressure
- Suitable for heat shrinkable joints and terminations

**Material**

- Cross-linked polyolefin
- Free of lead and cadmium

**Test standards**

- Corresponds to IEC 60684-2

**Storage conditions/Shelf life**

- Unlimited shelf life

**Colours**

Black

**Scope of delivery**

Medium wall heat shrinkable tube in lengths

Note: Other lengths available on request.

Type	L m	Inner-Ø mm		Recovered wall thickness mm	Art.-No.	
		before shrinking	after shrinking			
<b>Lengths   Colour: Black</b>						
<b>SRFH2</b>	8-2.5	1	8	2.5	2	156847
	12-4	1	12	4	2.6	144493
	21-7	1	21	7	2.6	144498

Technical data	Value	Test standard
<b>Physical properties</b>		
Hardness	51 Shore D	DIN 53 505
Elongation at break	350 %	IEC 60684-2
Tensile strength at break	13 MPa	IEC 60684-2
Longitudinal shrinkage	≤ 10 %	IEC 60684-2
Shrink ratio	3:1	IEC 60684-2
Eccentricity expanded recovered	50 % 85 %	IEC 60684-2
<b>Thermal properties</b>		
Operating temperature range	-40 °C up to 120 °C	IEC 60684-2
Shrinkage temperature	> 125 °C	
Burning behaviour	self-extinguishing	IEC 60684-2 method C
Flexibility at low temperatures	-40 °C	IEC 60684-2
Thermal ageing (168 h at 150 °C)		
Elongation at break	250 %	
Tensile strength at break	12 MPa	IEC 60684-2
<b>Electrical properties</b>		
Dielectric strength	25 kV/mm	IEC 60684-2
Specific volume resistivity	10 <sup>14</sup> Ω x cm	IEC 60684-2
<b>Chemical properties</b>		
Corrosion	None	IEC 60684-2
Resistance to fungus and decay	Rate 1	IEC 60684-2





## SR3, SRH3

### Heat shrinkable thick wall tube

halogen-free, shrink ratio 3 : 1, with or without adhesive

#### Characteristics

- Thick wall
- Inscrutable
- Resistant to chemical agents
- Stabilized against UV rays
- Free from paint-wetting inhibiting substances
- Halogen-free
- Non-corrosive
- Infusible
- Superior electrical properties
- High tensile strength
- Resistant to cold flow (thermally stable)

#### Application/Suitability

- Insulating
- Protection against moisture and pressure
- Suitable for heat shrinkable joints and terminations

#### Material

- Cross-linked polyolefin
- Free of lead and cadmium

#### Test standards

- Corresponds to IEC 60684-2

#### Storage conditions/Shelf life

- Unlimited shelf life



#### Colours



Black

#### Scope of delivery

Thick wall heat shrinkable tube in lengths

Note: Other lengths available on request.

Type	L m	Inner-Ø mm		Recovered wall thickness mm	Art.-No.	
		before shrinking	after shrinking			
<b>without adhesive</b>						
<b>Lengths   Colour: Black</b>						
SR3	12-3	1	12	3	2.6	127487
	22-6	1	22	6	2.7	127488
	33-8	1	33	8	4	144613
	45-12	1	45	12	4.4	127490
	55-15	1	55	15	4.4	144620
	75-20	1	75	20	4.5	144596
	92-25	1	92	25	4.6	127493
	130-34	1	130	34	4.8	127494
<b>with adhesive</b>						
<b>Lengths   Colour: Black</b>						
SRH3	12-3	1	12	3	2.6	127503
	16-4	1	16	4	3.1	135860
	22-6	1	22	6	2.7	127505
	33-8	1	33	8	4	127507
	45-12	1	45	12	4.4	127510
	55-15	1	55	15	4.4	127511
	75-20	1	75	20	4.5	127522
	92-25	1	92	25	4.6	127515
	130-34	1	130	34	4.8	144863
	160-50	1	160	50	4.6	158903

→ Continued on the next page



→ Continuation

**SR3, SRH3 Heat shrinkable thick wall tube**

Technical data	Value	Test standard
<b>Physical properties</b>		
Hardness	55 Shore D	DIN 53 505
Elongation at break	350 %	IEC 60684-2
Tensile strength at break	13 MPa	IEC 60684-2
Longitudinal shrinkage	≤ 10 %	IEC 60684-2
Shrink ratio	3:1	IEC 60684-2
Eccentricity expanded	50 %	IEC 60684-2
recovered	85 %	
<b>Thermal properties</b>		
Operating temperature range	-40 °C up to 120 °C	IEC 60684-2
Shrinkage temperature	> 125 °C	
Burning behaviour	self-extinguishing	IEC 60684-2 method C
Flexibility at low temperatures	-40 °C	IEC 60684-2
Thermal ageing (168 h at 150 °C)		
Elongation at break	250 %	IEC 60684-2
Tensile strength at break	12 MPa	
<b>Electrical properties</b>		
Dielectric strength	25 kV/mm	IEC 60684-2
Specific volume resistivity	10 <sup>14</sup> Ω x cm	IEC 60684-2
<b>Chemical properties</b>		
Corrosion	None	IEC 60684-2
Resistance to fungus and decay	Rate 1	IEC 60684-2



## SRFH3

### Heat shrinkable thick wall tube

self-extinguishing, shrink ratio 3 : 1, with adhesive

#### Characteristics

- Thick wall
- Inscrutable
- Resistant to chemical agents
- Stabilized against UV rays
- Free from paint-wetting inhibiting substances
- Non-corrosive
- Infusible
- Superior electrical properties
- High tensile strength
- Resistant to cold flow (thermally stable)
- Self-extinguishing

#### Application/Suitability

- Insulating
- Protection against moisture and pressure
- Suitable for heat shrinkable joints and terminations

#### Material

- Cross-linked polyolefin
- Free of lead and cadmium

#### Test standards

- Corresponds to IEC 60684-2

#### Storage conditions/Shelf life

- Unlimited shelf life



#### Colours



Black

#### Scope of delivery

Thick wall heat shrinkable tube in lengths

Note: Other lengths available on request.

Type	L m	Inner-Ø mm		Recovered wall thickness mm	Art.-No.	
		before shrinking	after shrinking			
Lengths   Colour: Black						
SRFH3	30-8	1	30	8	3.5	144527
	40-13	1	40	13	3.5	144536
	55-18	1	55	18	3.8	144545
	80-26	1	80	26	3.8	144559

Technical data	Value	Test standard
<b>Physical properties</b>		
Hardness	51 Shore D	DIN 53 505
Elongation at break	350 %	IEC 60684-2
Tensile strength at break	13 MPa	IEC 60684-2
Longitudinal shrinkage	≤ 10 %	IEC 60684-2
Shrink ratio	3:1	IEC 60684-2
Eccentricity expanded recovered	50 % 85 %	IEC 60684-2
<b>Thermal properties</b>		
Operating temperature range	-40 °C up to 120 °C	IEC 60684-2
Shrinkage temperature	> 125 °C	
Burning behaviour	self-extinguishing	IEC 60684-2 method C
Flexibility at low temperatures	-40 °C	IEC 60684-2
Thermal ageing (168 h at 150 °C)		
Elongation at break	250 %	
Tensile strength at break	12 MPa	IEC 60684-2
<b>Electrical properties</b>		
Dielectric strength	25 kV/mm	IEC 60684-2
Specific volume resistivity	10 <sup>14</sup> Ω x cm	IEC 60684-2
<b>Chemical properties</b>		
Corrosion	None	IEC 60684-2
Resistance to fungus and decay	Rate 1	IEC 60684-2



## SRBK-Set

### Heat shrinkable thick wall tube

anti-slip, halogen-free, shrink ratio 3 : 1, with adhesive

Protection and mechanical connection of telecommunication cable plug-in systems.

#### Characteristics

- Thick wall
- Resistant to chemical agents
- Stabilized against UV rays
- Free from paint-wetting inhibiting substances
- Halogen-free
- Non-corrosive
- Infusible
- Superior electrical properties
- Excellent adhesion to all cable materials
- High tensile strength
- Resistant to cold flow (thermally stable)

#### Application/Suitability

- Telecommunications terminal block system

#### Material

- Cross-linked polyolefin
- Free of lead and cadmium

#### Test standards

- Corresponds to IEC 60684-2

#### Storage conditions/Shelf life

- Unlimited shelf life



#### Colours



Black

#### Scope of delivery

10 thick wall heat shrinkable tubes in lengths, 20 fire protection wrapping, 10 cleaning tissues, 10 emery cloths

Type	L mm	Inner-Ø mm		Recovered wall thickness mm	Art.-No.
		before shrinking	after shrinking		
SRBK-Set	25-7	170	25	7	146123
	32-8	210	32	8	146124

Technical data	Value	Test standard
<b>Physical properties</b>		
Hardness	50 Shore D	DIN 53 505
Elongation at break	350 %	IEC 60684-2
Tensile strength at break	13 MPa	IEC 60684-2
Longitudinal shrinkage	≤ 10 %	IEC 60684-2
Shrink ratio	3:1	IEC 60684-2
Eccentricity expanded recovered	50 % 85 %	IEC 60684-2
<b>Thermal properties</b>		
Operating temperature range	-40 °C up to 120 °C	IEC 60684-2
Shrinkage temperature	> 125 °C	
Burning behaviour	self-extinguishing	IEC 60684-2 method C
Flexibility at low temperatures	-40 °C	IEC 60684-2
Thermal ageing (168 h at 150 °C)		
Elongation at break	350 %	
Tensile strength at break	13 MPa	IEC 60684-2
<b>Electrical properties</b>		
Dielectric strength	20 kV/mm	IEC 60684-2
Specific volume resistivity	10 <sup>14</sup> Ω x cm	IEC 60684-2
<b>Chemical properties</b>		
Corrosion	None	IEC 60684-2
Resistance to fungus and decay	Rate 1	IEC 60684-2



# SKH, SKHD

## Heat shrinkable end cap

with adhesive, optionally with additional sealing material

Protection against humidity and pressure for cables, conductors and pipes with a diameter of 5 - 105 mm.

### Characteristics

- Stabilized against UV rays
- Free from paint-wetting inhibiting substances
- Halogen-free
- 100 % waterproof
- Pressure-tight
- Superior electrical properties
- High mechanical strength
- Resistant to chemical agents

### Application/Suitability

- Protection against moisture and pressure for cables, conductors and pipes

### Material

- Cross-linked polyolefin
- Free of lead and cadmium

### Test standards

- Corresponds to IEC 60684-2

### Storage conditions/Shelf life

- Unlimited shelf life



### Colours



Black

### Dimensions

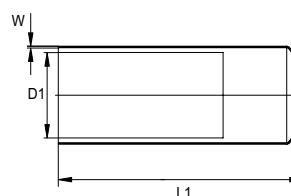

### Scope of delivery

Heat shrinkable end cap

Type	L1 mm	L1* mm	Inner-Ø D1 mm		W* Recovered wall thickness mm	Art.-No.	
			before shrinking	after shrinking			
<b>with adhesive</b>							
SKH	10-4	45	33	10	4	2	125345
	15-5	45	45	15	5	2	125351
	22-9	75	70	22	9	2.5	125334
	35-15	100	95	35	15	3	125335
	55-25	150	140	55	25	3.5	125336
	75-30	165	155	75	30	3.5	125337
	95-40	175	155	95	40	4	125338
110-45	145	130	110	45	4	125339	
<b>with adhesive and sealing</b>							
SKHD	35-15	100	97	35	15	3	143536
	55-25	150	135	55	25	3.5	143537
	75-30	165	155	75	30	4	143539
	95-40	170	130	95	40	4	143540

\* recovered dimension after shrinking

→ Continued on the next page



→ Continuation

**SKH, SKHD Heat shrinkable end cap**

Technical data	Value	Test standard
<b>Physical properties</b>		
Elongation at break	400 %	IEC 60684-2
Tensile strength at break	13 MPa	IEC 60684-2
Longitudinal shrinkage	≤ 15 %	IEC 60684-2
<b>Thermal properties</b>		
Operating temperature range	-30 °C up to 135 °C	IEC 60684-2
Shrinkage temperature	> 125 °C	
Burning behaviour	not self-extinguishing	IEC 60684-2 method C
Flexibility at low temperatures	-40 °C	IEC 60684-2
Thermal ageing (168 h at 150 °C)		
Elongation at break	300 %	
Tensile strength at break	12 MPa	IEC 60684-2
<b>Electrical properties</b>		
Dielectric strength	17 kV/mm	IEC 60684-2
Specific volume resistivity	10 <sup>15</sup> Ω x cm	IEC 60684-2
Dielectric constant	5.0	IEC 60684-2
<b>Chemical properties</b>		
Corrosion	None	IEC 60684-2
Resistance to fungus and decay	Rate 1	IEC 60684-2



## SEH

# Heat shrinkable spreader cap

for 2-, 3-, 4-, 5-core cables and conductors, with adhesive

Sealing spreader caps for plastic-, rubber- and paper-insulated cables.

### Characteristics

- Stabilized against UV rays
- Free from paint-wetting inhibiting substances
- Halogen-free
- 100 % waterproof
- Pressure-tight
- Superior electrical properties
- Superior mechanical properties

### Application/Suitability

- Indoor
- Outdoor

### Material

- Cross-linked polyolefin
- Free of lead and cadmium

### Test standards

- Corresponds to IEC 60684-2

### Storage conditions/Shelf life

- Unlimited shelf life



### Scope of delivery

Heat shrinkable spreader cap

### Colours



Black

### Dimensions

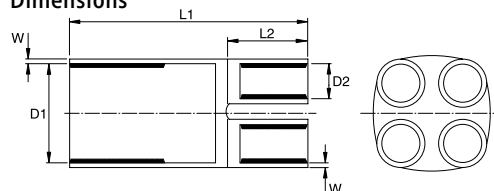

Type	L1 mm	L1* mm	L2 mm	Inner-Ø D1 mm		Inner-Ø D2 mm		W* Recovered wall thickness mm	Nominal cross section mm <sup>2</sup>	Art.-No.	
				before shrinking	after shrinking	before shrinking	after shrinking				
<b>2-fingers spreader cap</b>											
SEH2	30-10	65	90	15	30	10	12	4	1.5	2.5 - 25	125374
	50-24	85	120	25	50	24	21	7	3	25 - 120	169475
	60-20	90	130	40	60	20	36	18	3	95 - 150	125373
<b>3-fingers spreader cap</b>											
SEH3	25-9	50	70	15	25	9	9	3	2.5	1.5 - 16	169471
	35-15	85	100	20	35	15	13	4	2.5	6 - 35	125365
	55-23	130	170	30	55	23	25	9	3	35 - 150	169473
	75-28	170	200	40	75	28	35	13	3.5	120 - 300	186615
	110-35	180	210	45	110	35	50	17	4	185 - 400	169711
125-59	185	260	50	125	59	60	24	3.5	240 - 500	125371	
<b>4-fingers spreader cap</b>											
SEH4	28-9	55	70	15	28	9	8	2	2	1.5 - 10	148844
	35-15	80	100	20	35	15	13	4	2.5	6 - 35	143556
	47-23	130	170	30	47	23	20	8	3.5	35 - 95	166973
	60-25	160	180	30	60	25	25	8	3.5	35 - 150	169477
	78-36	170	220	40	78	36	30	12	3.5	95 - 240	166972
95-36	170	220	45	96	36	35	14	4	120 - 300	143563	
<b>5-fingers spreader cap</b>											
SEH5	65-15	82	100	31	65	15	22	3	4	4 - 70	222242
	80-33	150	175	53	80	33	26	8	3	35 - 150	223131
	100-42	170	190	60	100	42	34	10	3	95 - 240	223132

\*recovered dimension after shrinking

→ Continued on the next page



→ Continuation

**SEH Heat shrinkable spreader cap**

Technical data	Value	Test standard
<b>Physical properties</b>		
Elongation at break	300 %	IEC 60684-2
Tensile strength at break	10 MPa	IEC 60684-2
Longitudinal shrinkage	≤ 10 %	IEC 60684-2
<b>Thermal properties</b>		
Operating temperature range	-30 °C up to 135 °C	IEC 60684-2
Shrinkage temperature	> 125 °C	
Burning behaviour	not self-extinguishing	IEC 60684-2 method C
Flexibility at low temperatures	-40 °C	IEC 60684-2
Thermal ageing (168 h at 150 °C)		
Elongation at break	200 %	
Tensile strength at break	12 MPa	IEC 60684-2
<b>Electrical properties</b>		
Dielectric strength	10 kV/mm	IEC 60684-2
Specific volume resistivity	10 <sup>14</sup> Ω x cm	IEC 60684-2
Dielectric constant	5.0	IEC 60684-2
<b>Chemical properties</b>		
Corrosion	None	IEC 60684-2
Resistance to fungus and decay	Rate 1	IEC 60684-2





## SRMAHV

### Heat shrinkable repair sleeve

with adhesive and stainless steel channel

For repairing damaged sheaths of all polymeric- and rubber-insulated cables and conductors.

#### Characteristics

- Medium wall
- Resistant to chemical agents
- Stabilized against UV rays
- Free from paint-wetting inhibiting substances
- Halogen-free
- Non-corrosive
- Infusible
- Maximum inner pressure: 1.5 bar
- Superior electrical properties
- High tensile strength
- Resistant to cold flow (thermally stable)

#### Application/Suitability

- Sealing
- Repair of damaged cable sheaths

#### Material

- Cross-linked polyolefin
- Free of lead and cadmium

#### Test standards

- Corresponds to IEC 60684-2

#### Storage conditions/Shelf life

- Unlimited shelf life



#### Colours



Black

#### Scope of delivery

Heat shrinkable repair sleeve, stainless steel channel, assembly instructions

Type	Inner-Ø mm		Application range mm		Recovered wall thickness mm	Art.-No.
	before shrinking	after shrinking	min. shrinking	max. shrinking		
28-10 / 250	32	10	10	28	2.3	143595
28-10 / 500	32	10	10	28	2.3	143601
28-10 / 750	32	10	10	28	2.3	143605
28-10 / 1000	32	10	10	28	2.3	143592
43-12 / 250	52	12	12	43	3.4	165912
43-12 / 500	52	12	12	43	3.4	166012
43-12 / 750	52	12	12	43	3.4	166013
43-12 / 1000	52	12	12	43	3.4	166016
43-12 / 1500	52	12	12	43	3.4	143627
72-18 / 250	82	18	18	72	3.4	143630
72-18 / 500	82	18	18	72	3.4	143632
72-18 / 750	82	18	18	72	3.4	143637
72-18 / 1000	82	18	18	72	3.4	143628
72-18 / 1500	82	18	18	72	3.4	143646
72-18 / 2000	82	18	18	72	3.4	143629
SRMAHV 93-26 / 250	105	26	26	93	3.4	143649
93-26 / 500	105	26	26	93	3.4	143650
93-26 / 750	105	26	26	93	3.4	143654
93-26 / 1000	105	26	26	93	3.4	143647
93-26 / 2000	105	26	26	93	3.4	143648
115-30 / 250	130	30	30	115	2.3	143661
115-30 / 500	130	30	30	115	2.3	143663
115-30 / 750	130	30	30	115	2.3	143665
115-30 / 1000	130	30	30	115	2.3	143659
115-30 / 1500	130	30	30	115	2.3	143669
125-32 / 250	143	32	32	125	2.3	143671
125-32 / 500	143	32	32	125	2.3	143672
125-32 / 750	143	32	32	125	2.3	143673
125-32 / 1000	143	32	32	125	2.3	143670
125-32 / 1500	143	32	32	125	2.3	143679
198-50 / 1000	220	50	50	198	2.3	143680

→ Continued on the next page







→ Continuation

**SRMAHV Heat shrinkable repair sleeve**

Technical data	Value	Test standard
<b>Physical properties</b>		
Hardness	50 Shore D	IEC 60684-2
Elongation at break	300 %	IEC 60684-2
Tensile strength at break	13 MPa	IEC 60684-2
Longitudinal shrinkage	≤ 10 %	IEC 60684-2
Shrink ratio	> 3:1	IEC 60684-2
<b>Thermal properties</b>		
Operating temperature range	-40 °C up to 120 °C	IEC 60684-2
Shrinkage temperature	> 125 °C	
Flexibility at low temperatures	-40 °C	IEC 60684-2
Thermal ageing (168 h at 150 °C)		
Tensile strength at break	12 MPa	IEC 60684-2
<b>Electrical properties</b>		
Dielectric strength	12 kV/mm	IEC 60684-2
Specific volume resistivity	10 <sup>15</sup> Ω x cm	IEC 60684-2
Dielectric constant	5.0	IEC 60684-2
<b>Chemical properties</b>		
Corrosion	None	IEC 60684-2
Resistance to fungus and decay	Rate 1	IEC 60684-2

## Cast resin technology

	Straight-through joints .....	77
	Branch joints .....	86
	Universal connection and branch boxes .....	101
	Cast resins .....	102

## Overview: Cellpack Cast resin straight-through and branch joints / Universal connection and branch boxes

Products	Version		Type of cast resins					
	with screw connector(s)	with branch clamp(s)	EG	GG	KG	FG	UWR	
<b>Straight-through joints</b>								
MR 0	-	-	●	-	-	-	-	
M	-	-	●	-	-	-	-	
M-Euroline	-	-	●	-	-	-	-	
M...V-Euroline	●	-	●	-	-	-	-	
MZ	-	-	●	-	-	-	-	
MZ...FG	-	-	-	-	-	●	-	
PV...EG, PVM...EG, PVS...EG	-	-	●	-	-	-	-	
PVS...GG	-	-	-	●	-	-	-	
<b>Branch joints</b>								
KA, KAV	-	-	●	-	-	-	-	
H	-	-	●	-	-	-	-	
H 5-SYS	-	●	-	-	-	-	●	
P...EG	-	-	●	-	-	-	-	
P...GG	-	-	-	●	-	-	-	
T	-	-	●	-	-	-	-	
T...V AK	-	●	●	-	-	-	-	
Y	-	-	●	-	-	-	-	
Y...V AK	-	●	●	-	-	-	-	
YCP	-	-	●	-	-	-	-	
D1	-	-	●	-	-	-	-	
<b>Universal connection and branch boxes</b>								
Universal Box KG	-	●	-	-	●	-	-	

- included in the scope of delivery
- not included in the scope of delivery



## MR 0

# Cast resin straight-through joint

particularly for small cross sections, for polymeric cables and conductors, control cables and signal cables

Universally suitable for connecting polymeric cables or conductors insulated with PVC, PE, XLPE and EPR (e.g. N(A)YY, NYM, TT). Suitable for compression connectors on copper and aluminium conductors.

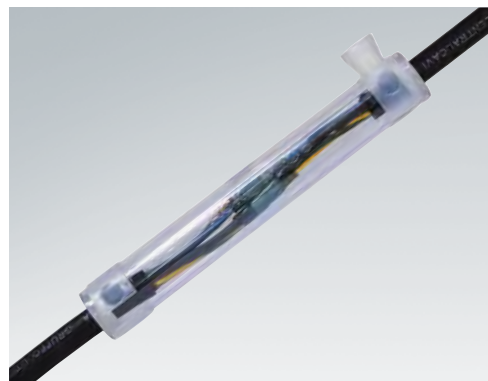

### Characteristics

- Compact dimensions
- Splice area visible before casting
- High-quality transparent shockproof plastic shell
- Funnel clips for easy casting
- Suitable for vertical casting
- Resistant to chemical agents
- Resistant to alkaline earth elements
- Stabilized against UV rays
- Longitudinally and transversely water-tight
- High electrical insulating values
- High mechanical strength
- Ready for immediate operation
- Quick and easy assembly saves time and reduces costs

### Application/Suitability

- Indoor
- Outdoor
- Underground
- Water
- Submersible pumps
- Installation ducts

### Voltage level

- $U_0/U_m$  0.6/1 (1.2) kV

### Test standards

- DIN EN 50393 (corresponds to VDE 0278)

### Storage conditions/Shelf life

- Cast resin up to 40 months



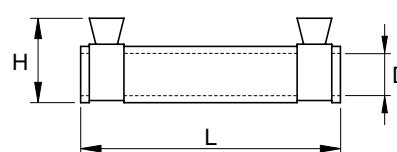

### Dimensions



### Scope of delivery

Cover, hydrolysis resistance PUR type EG cast resin (containing the correct volume ready for mixing), packed in practical and easy-to-use two-chamber bags, transparent plastic shell, spacers, PVC insulation tape, protective gloves, funnel clips, assembly instructions

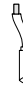
Optional accessory: Funnel set/Filling in funnel (on request)  
Compression connectors (see Connecting technology)  
Cleaner UNIVERSAL CLEANER 121 (see Accessories)

						Polymeric cable					
						unarmoured					
											
Type	L mm	D mm	H mm	max. Cable-Ø mm	Nominal cross section per conductor mm <sup>2</sup>					Art.-No.	
MR	02	120	26	40	16	25	6	4	2.5	1.5	124507
	05	180	26	40	16	25	6	4	4	2.5	124508

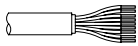
						Control and signal cable			
									
						0.75 mm <sup>2</sup>	1.5 mm <sup>2</sup>		
Type	L mm	D mm	H mm	max. Cable-Ø mm	Number of conductors			Art.-No.	
MR	02	120	26	40	16	8	5	124507	
	05	180	26	40	16	16	8	124508	



# M Cast resin straight-through joint

for polymeric cables and conductors, control cables and signal cables

Universally suitable for connecting polymeric cables or conductors insulated with PVC, PE, XLPE and EPR (e.g. N(A)YY, NYM, TT). Suitable for compression or screw connectors on copper and aluminium conductors.

### Characteristics

- Compact dimensions
- Splice area visible before casting
- High-quality transparent shockproof plastic shell
- Resistant to chemical agents
- Resistant to alkaline earth elements
- Stabilized against UV rays
- Longitudinally and transversely water-tight
- High electrical insulating values
- High mechanical strength
- Ready for immediate operation
- Quick and easy assembly saves time and reduces costs

### Application/Suitability

- Indoor
  - Outdoor
  - Underground
  - Water
  - Installation ducts
- Voltage level**
- $U_0/U_m$  0.6/1 (1.2) kV
- Test standards**
- DIN EN 50393 (corresponds to VDE 0278)
- Storage conditions/Shelf life**
- Cast resin up to 40 months



### Dimensions

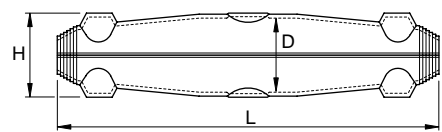

M 0 - M 6

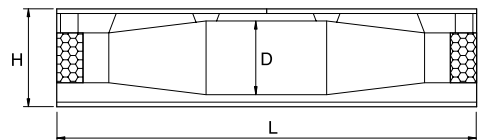

M 7 - M 8

### Scope of delivery

Hydrolysis resistance PUR type EG cast resin (containing the correct volume ready for mixing), packed in practical and easy-to-use two-chamber bags, transparent plastic shell, fill and air-release funnels, PVC insulation tape, protective gloves, assembly instructions

Optional accessory: Shield continuity wire SVL (see Accessories)  
Connectors (see Connecting technology)  
Cleaner UNIVERSAL CLEANER 121 (see Accessories)

Note: Armour continuity kit for armoured cable available on request.

Type	L mm	D mm	H mm	max. Cable-Ø mm	Polymeric cable								Art.-No.	
					unarmoured					with concentric conductor		armoured		
					1x	2x	3x	4x	5x	3x	4x	3x		4x
max. Nominal cross section per conductor mm <sup>2</sup>														
0	185	32	37	15	25	10	6	6	4					124293
1	240	40	45	22	95	25	16	16	10	10/10				124294
2	265	45	50	30	185	50	35	25	16	25/25	16/16	16	16	124295
2.5	310	58	65	37	300	70	70	50	35	35/35	25/25	35	16 - 35	124296
3	355	70	80	42	400	120	95	70	50	50/50	50/25	50	35 - 50	124297
4	430	90	98	52	500		120	95	70	95/95	70/35	95	50 - 95	124298
5	550	110	120	62	1000		240	185	120	150/150	120/70	120	95 - 120	124299
6	660	145	165	80			300	240	185	240/240	240/120	240	120 - 240	124300
7	900	150	190	90			400	300	240					124308
8	1100	150	190	90						400/400	300/150	400	300 - 400	124309

→ Continued on the next page



→ Continuation

## M Cast resin straight-through joint

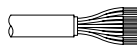
Control and signal cable											
											
					0.4 mm <sup>2</sup>	0.6 mm <sup>2</sup>	0.8 mm <sup>2</sup>	0.75 mm <sup>2</sup>	1.5 mm <sup>2</sup>		
Type	L mm	D mm	H mm	max. Cable-Ø mm	Number of wire pairs			Number of conductors		Art.-No.	
M	0	185	32	37	15	6 - 20	6 - 10	6	16	8	124293
	1	240	40	45	22	30 - 70	20 - 30	10 - 20	56	21	124294
	2	265	45	50	30	100 - 150	40 - 70	30 - 40	114	56	124295
	2.5	310	58	65	37	200 - 250	100 - 120	50 - 70	154	96	124296
	3	355	70	80	42	300	150	100 - 120	200	133	124297

Shield continuity wire SVL required for telecommunication cables.







## M...V-Euroline Cast resin straight-through joint

with screw connectors, for polymeric cables and conductors

Universally suitable for connecting polymeric cables or conductors insulated with PVC, PE, XLPE and EPR (e.g. N(A)YY, NYM, TT). With screw connectors, suitable for aluminium or copper conductors.

### Characteristics

- Compact dimensions
- Splice area visible before casting
- High-quality transparent shockproof plastic shell
- Large filler aperture to facilitate casting
- Resistant to chemical agents
- Resistant to alkaline earth elements
- Stabilized against UV rays
- Longitudinally and transversely water-tight
- High electrical insulating values
- High mechanical strength
- Ready for immediate operation
- Quick and easy assembly saves time and reduces costs

### Application/Suitability

- Indoor
  - Outdoor
  - Underground
  - Water
  - Installation ducts
- Voltage level**
- $U_0/U_m$  (U<sub>m</sub>) 0.6/1 (1.2) kV
- Test standards**
- DIN EN 50393 (corresponds to VDE 0278)
- Storage conditions/Shelf life**
- Cast resin up to 40 months

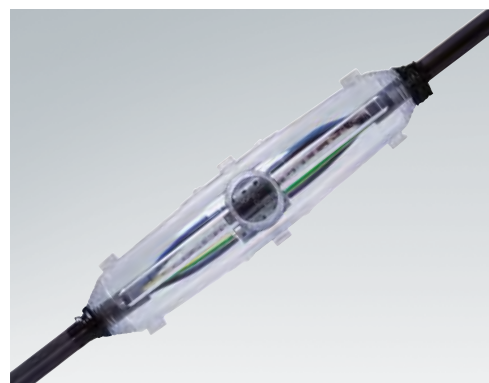

Dimensions

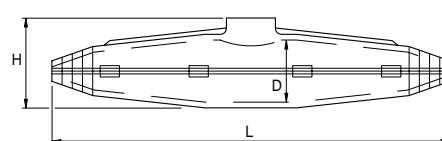

### Scope of delivery

Cover, hydrolysis resistance PUR type EG cast resin (containing the correct volume ready for mixing), packed in practical and easy-to-use two-chamber bags, transparent plastic shell, screw connectors, spacers (up to M13), PVC insulation tape, protective gloves, assembly instructions

Optional accessory: Cleaner UNIVERSAL CLEANER 121 (see Accessories)

Type	L mm	D mm	H mm	max. Cable-Ø mm	Polymeric cable					Art.-No.	
					unarmoured			with concentric conductor			
					3x	4x	5x	3x	4x		
M	11 V	190	36	50	26	1.5 - 6	1.5 - 6	1.5 - 6	1.5/1.5 - 6/6	1.5/1.5 - 6/6	131863
	12 V	260	47	63	34	10 - 16	10 - 16	10 - 16	10/10 - 16/16	10/10 - 16/16	131867
	13 SV	310	55	68	43	16 - 25	16 - 25		16/16 - 25/25		131866
	13 V	360	55	75	43	25 - 35	25 - 35		25/25 - 35/35		131864
	14 V	400	70	95	48	50 - 70	50 - 70		50/50 - 70/70		131865



## MZ

# Cast resin straight-through joint

for control cables and signal cables

Universally suitable for connecting control cables and signal cables or as a cable sheath repair protection joint. Suitable for compression connectors.

### Characteristics

- Compact dimensions
- Splice area visible before casting
- High-quality transparent shockproof plastic shell
- Large filler aperture to facilitate casting
- Resistant to chemical agents
- Resistant to alkaline earth elements
- Stabilized against UV rays
- Longitudinally and transversely water-tight
- High electrical insulating values
- High mechanical strength
- Ready for immediate operation
- Quick and easy assembly saves time and reduces costs

### Application/Suitability

- Indoor
- Outdoor
- Underground
- Water
- Installation ducts

### Voltage level

- $U_0/U_m$  0.6/1 (1.2) kV

### Test standards

- DIN EN 50393 (corresponds to VDE 0278)

### Storage conditions/Shelf life

- Cast resin up to 40 months



### Dimensions

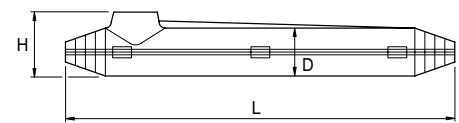

MZ 00 - MZ 0

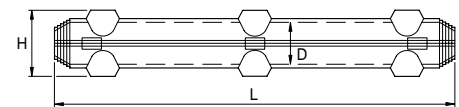

MZ 1 - MZ 5

### Scope of delivery

Cover, hydrolysis resistance PUR type EG cast resin (containing the correct volume ready for mixing), packed in practical and easy-to-use two-chamber bags, transparent plastic shell, spacer mesh, fill and air-release funnels, PVC insulation tape, protective gloves, assembly instructions

Optional accessory: Shield continuity wire SVL (see Accessories)  
 Compression connectors (see Connecting technology)  
 Cleaner UNIVERSAL CLEANER 121 (see Accessories)

Type	L mm	D mm	H mm	max. Cable-Ø mm	Control and signal cable					Art.-No.
					0.4 mm <sup>2</sup>	0.6 mm <sup>2</sup>	0.8 mm <sup>2</sup>	1.5 mm <sup>2</sup>	2.5 mm <sup>2</sup>	
					Number of wire pairs			Number of conductors		
MZ 00	180	23	35	20	10 - 15	5 - 10	5 - 10	7	5	124505
MZ 0	250	35	55	32	15 - 30	10 - 20	10 - 20	15	10	124506
MZ 1	400	33	57	30	30 - 60	20 - 50	20 - 40	30	20	124510
MZ 2	500	41	67	40	70 - 100	60 - 100	50 - 70	50	40	124513
MZ 3	600	51	78	50	150 - 200	150 - 250	100 - 150	60	50	124511

Shield continuity wire SVL required for telecommunication cables.



## MZ...FG

### Cast resin straight-through joint

drummable, with flexibel cast resin, for unarmoured polymeric cables and conductors

Universally applicable as repair joints for flexible rubber cable.

#### Characteristics

- Compact dimensions
- Splice area visible before casting
- High-quality transparent shockproof plastic shell
- Resistant to chemical agents
- Resistant to alkaline earth elements
- Stabilized against UV rays
- Longitudinally and transversely water-tight
- High electrical insulating values
- High mechanical strength
- Ready for immediate operation
- Quick and easy assembly saves time and reduces costs

#### Application/Suitability

- Indoor
  - Outdoor
  - Underground
  - Water
  - Installation ducts
- Voltage level**
- $U_0/U_m$  0.6/1 (1.2) kV
- Test standards**
- DIN EN 50393 (corresponds to VDE 0278)
- Storage conditions/Shelf life**
- Cast resin up to 24 months

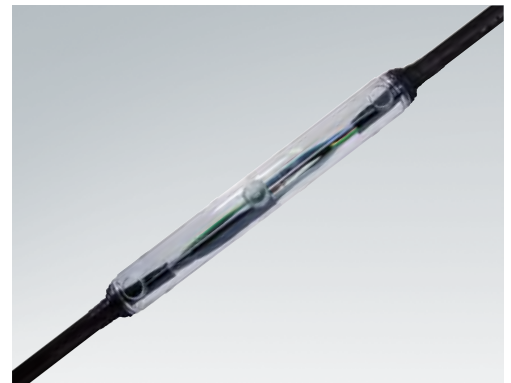

#### Dimensions

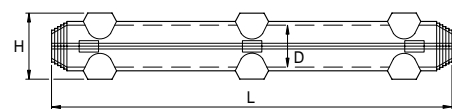

#### Scope of delivery

Hydrolysis resistance PUR type FG cast resin (containing the correct volume ready for mixing), packed in practical and easy-to-use two-chamber bags, transparent plastic shell, heat shrinkable tubes for connectors, fill and air-release funnels, PVC insulation tape, protective gloves, assembly instructions

Optional accessory: Cleaner UNIVERSAL CLEANER 121 (see Accessories)

		Polymeric cable						
		unarmoured						
		4x		5x				
Type	L mm	D mm	H mm	max. Cable-Ø mm	max. Nominal cross section per conductor mm <sup>2</sup>		Art.-No.	
MZ	1 FG	400	33	57	30	10	6	124516
	2 FG	500	41	67	40	25	16	124517
	3 FG	600	51	78	50	50	25	124518



## PV...EG, PVM...EG, PVS...EG Cast resin straight-through joint

with integrated strain relief, for polymeric cables and conductors, with cast resin EG

Universally suitable for connecting polymeric cables or conductors insulated with PVC, PE, XLPE and EPR (e.g. N(A)YY, TT) and mass-impregnated paper cables. Suitable for compression or screw connectors on copper and aluminium conductors.

### Characteristics

- Compact dimensions
- High-quality brown shockproof plastic shell
- Integrated strain relief
- Large filler aperture to facilitate casting
- Resistant to chemical agents
- Resistant to alkaline earth elements
- Stabilized against UV rays
- Longitudinally and transversely water-tight
- High electrical insulating values
- High mechanical strength
- Ready for immediate operation
- Quick and easy assembly saves time and reduces costs

### Application/Suitability

- Indoor
- Outdoor
- Underground
- Water
- Installation ducts

### Voltage level

- $U_0/U_m$  0.6/1 (1.2) kV

### Test standards

- DIN EN 50393 (corresponds to VDE 0278)

### Storage conditions/Shelf life

- Cast resin up to 40 months

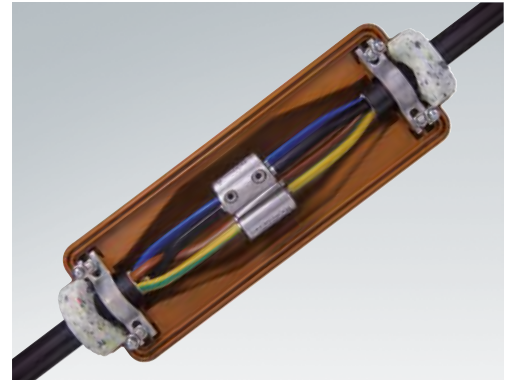

Dimensions

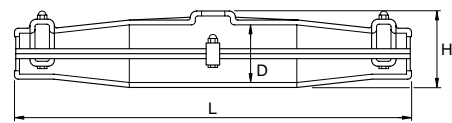

### Scope of delivery

Hydrolysis resistance PUR type EG cast resin (containing the correct volume ready for mixing), packed in practical and easy-to-use two-chamber bags, sealing gaskets, plastic shell, protective gloves, strain relief, assembly instructions

Optional accessory: Connectors (see Connecting technology)  
Cleaner UNIVERSAL CLEANER 121 (see Accessories)

Type	L mm	D mm	H mm	max. Cable-Ø mm	Polymeric cable				Art.-No.	
					unarmoured		with concentric conductor			
					3x	4x	3x	4x		
					Nominal cross section per conductor mm <sup>2</sup>					
PV	3 EG	427	100	120	40	50 - 95	35 - 70	70/70	50/50	127705
PVM	5 EG	642	116	135	48	95 - 150	95 - 150	150/150	120/120	127706
PVS	5 EG	642	136	160	48	95 - 150	95 - 150	150/150	120/120	127708
PVM	6 EG	850	137	185	58	185 - 300	185 - 240	240/120	185/185	127707



**PVS...GG** **NEW**

# Cast resin straight-through joint

with integrated strain relief, for polymeric cables and conductors, with cast resin GG (reduced hazard-class)

Universally suitable for connecting polymeric cables or conductors insulated with PVC, PE, XLPE and EPR (e.g. N(A)YY, TT) and mass-impregnated paper cables. Suitable for compression or screw connectors on copper and aluminium conductors.

**Characteristics**

- Compact dimensions
- High-quality brown shockproof plastic shell
- Integrated strain relief
- Large filler aperture to facilitate casting
- Resistant to chemical agents
- Resistant to alkaline earth elements
- Stabilized against UV rays
- Longitudinally and transversely water-tight
- High electrical insulating values
- High mechanical strength
- Ready for immediate operation
- Quick and easy assembly saves time and reduces costs

**Application/Suitability**

- Indoor
- Outdoor
- Underground
- Water
- Installation ducts

**Voltage level**

- $U_0/U_m$  (U<sub>m</sub>) 0.6/1 (1.2) kV

**Test standards**

- DIN EN 50393 (corresponds to VDE 0278)

**Storage conditions/Shelf life**

- Cast resin up to 24 months

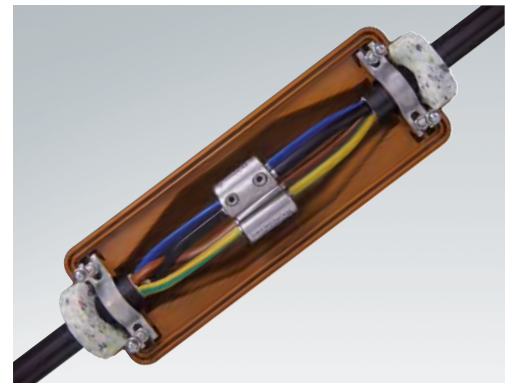



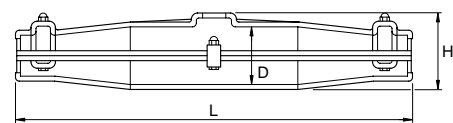

**Dimensions**



**Scope of delivery**

Hydrolysis resistance PUR type GG cast resin (containing the correct volume ready for mixing), packed in practical and easy-to-use two-chamber bags, sealing gaskets, plastic shell, protective gloves, strain relief, assembly instructions

Optional accessory: Connectors (see Connecting technology)  
Cleaner UNIVERSAL CLEANER 121 (see Accessories)

						Polymeric cable				
						unarmoured		with concentric conductor		
										
						3x	4x	3x	4x	
Type	L mm	D mm	H mm	max. Cable-Ø mm	Nominal cross section per conductor mm <sup>2</sup>				Art.-No.	
PVS	5 GG	642	136	160	48	95 - 150	95 - 150	150/150	120/120	335567

LOW VOLTAGE  
Cast resin technology



## KA, KAV

### Cast resin branch joint

for polymeric cables and conductors

Universally suitable for branching cables and conductors insulated with PVC, PE and XLPE (e.g. N(A)YY, GKN). Suitable for cable branch clamps / ring clamps and compression connectors on copper and aluminium conductors.

#### Characteristics

- Compact dimensions
- Splice area visible before casting
- High-quality transparent shockproof plastic shell
- Large filler aperture to facilitate casting
- Resistant to chemical agents
- Resistant to alkaline earth elements
- Stabilized against UV rays
- Longitudinally and transversely water-tight
- High electrical insulating values
- High mechanical strength
- Ready for immediate operation
- Quick and easy assembly saves time and reduces costs

#### Application/Suitability

- Indoor
- Outdoor
- Underground
- Water
- Installation ducts

#### Voltage level

- $U_0/U_m$  0.6/1 (1.2) kV

#### Test standards

- DIN EN 50393 (corresponds to VDE 0278)

#### Storage conditions/Shelf life

- Cast resin up to 40 months



#### Dimensions

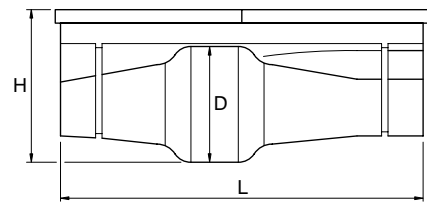

KA 4.5 - KA 6

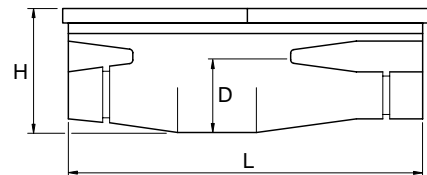

KAV 1 - KAV 2



#### Scope of delivery

Hydrolysis resistance PUR type EG cast resin (containing the correct volume ready for mixing), packed in practical and easy-to-use two-chamber bags, sealing gaskets, transparent plastic shell with locking bar, sealing tape, protective gloves, assembly instructions

- Optional accessory:
- Ring clamp (see Connecting technology)
  - Screw branch clamp AK (see Connecting technology)
  - Split bolt clamp FK (see Connecting technology)
  - Compression connectors (see Connecting technology)
  - Cleaner UNIVERSAL CLEANER 121 (see Accessories)

Note: Additional earthing set available on request.



		Polymeric cable					
		unarmoured		armoured			
							
		4x		4x			

Type	L mm	D mm	H mm	max. Cable-Ø mm		Nominal cross section per conductor mm <sup>2</sup>				Art.-No.
				Main cable	Branch cable	Main cable	Branch cable	Main cable	Branch cable	
KA 4.5	340	118	135	55	33	150	35	25	16	190195
KA 6	400	132	150	55	45	150	95	70	35	124865
KAV 1	230	58	78	30	20	16	6			181014
KAV 2	270	58	78	33	20	25	10	6	4	124861



# H Cast resin branch joint

for polymeric cables and conductors

Universally suitable for branching cables and conductors insulated with PVC, PE and XLPE (e.g. N(A)YY, TT...). Suitable for assembly of individual one-core branch clamps according to type (split bolt clamps for H1 and H2) or branch clamps (H5... and H6) and compression or screw connectors.

### Characteristics

- Compact dimensions
- Splice area visible before casting
- High-quality transparent shockproof plastic shell
- Can be used as double-branch joint (H1 and H2)
- Large filler aperture to facilitate casting
- Resistant to chemical agents
- Resistant to alkaline earth elements
- Stabilized against UV rays
- Longitudinally and transversely water-tight
- High electrical insulating values
- High mechanical strength
- Ready for immediate operation
- Quick and easy assembly saves time and reduces costs

### Application/Suitability

- Indoor
- Outdoor
- Underground
- Water
- Installation ducts

### Voltage level

- $U_0/U_m$  0.6/1 (1.2) kV

### Test standards

- DIN EN 50393 (corresponds to VDE 0278)

### Storage conditions/Shelf life

- Cast resin up to 40 months



### Dimensions

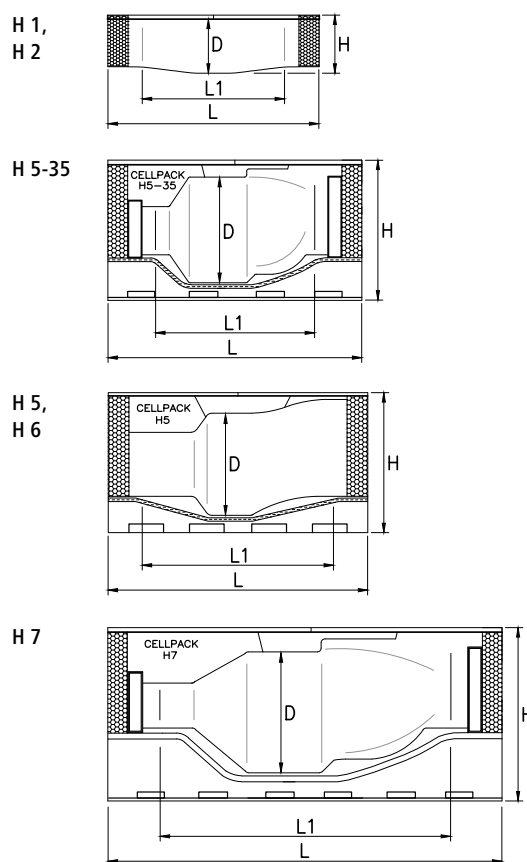

### Scope of delivery

Hydrolysis resistance PUR type EG cast resin (containing the correct volume ready for mixing), packed in practical and easy-to-use two-chamber bags, sealing gaskets, transparent plastic shell, centring elements (H5-35 and H7), steel clamps (H5 and H6), protective gloves, assembly instructions

Optional accessory: Screw branch clamp AK (see Connecting technology)  
Branch clamp HE 1/70/150 (see Connecting technology)  
Split bolt clamp FK (see Connecting technology)  
Connectors (see Connecting technology)  
Cleaner UNIVERSAL CLEANER 121 (see Accessories)

Note: H5 branch joints can be used with branch clamps HE 1/70/150 (see Connecting technology).

Polymeric cable	
unarmoured	with concentric conductor
4x	3x

Type	L mm	L1 mm	D mm	H mm	max. Cable-Ø mm		Nominal cross section per conductor mm <sup>2</sup>				Art.-No.	
					Main cable	Branch cable	Main cable	Branch cable	Main cable	Branch cable		
H	1	235	155	60	70	25	20	16	6			124789
	2	270	180	60	80	32	22	16 - 25	6 - 10			124790
	5	300	246	115	170	50	32	95 - 150	16 - 50			124787
	5-35	290	180	135	185	52	36	95 - 150	16 - 70			124815
	6	350	296	135	190	55	39	120 - 185	50 - 70	120/70 - 150/70	35/16 - 70/35	124788
	7	490	330	180	230	59	54	95 - 240	70 - 150	95/95 - 240/240	70/70 - 150/150	124786



## H 5-SYS

### Cast resin branch joint for house connections

with branch clamp, for unarmoured polymeric cables

For branching of cables with insulation made of PVC, PE and XLPE (e.g. N(A)YY, GN-CLN...). With branch clamp, suitable for copper and aluminium conductors.

#### Characteristics

- High-quality transparent shockproof plastic shell
- Cast resin can be poured in with an angle up to 45° or laterally up to 45°
- Compatible with a branching system with specific contact geometry designed to facilitate connection of branch cable in visible area, ensuring safe handling
- Easy seal application
- Large filler aperture to facilitate casting
- Can be installed / operated while under voltage
- Resistant to chemical agents
- Resistant to alkaline earth elements
- Stabilized against UV rays
- High electrical insulating values
- High mechanical strength
- Ready for immediate operation
- Quick and easy assembly saves time and reduces costs

#### Application/Suitability

- Indoor
- Outdoor
- Underground
- Water
- Installation ducts

#### Voltage level

- $U_0/U_m$  0.6/1 (1.2) kV

#### Test standards

- DIN EN 50393 (corresponds to VDE 0278)

#### Storage conditions/Shelf life

- Cast resin up to 24 months

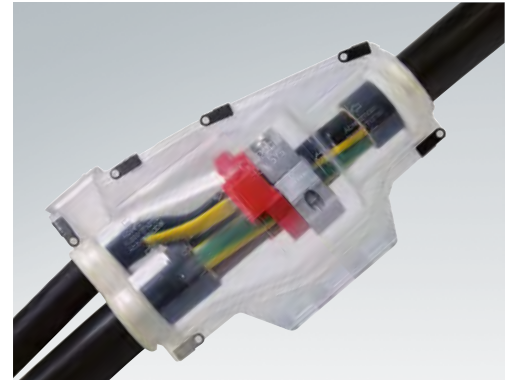

#### Dimensions

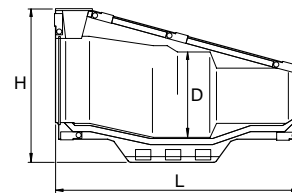

#### Scope of delivery

Hydrolysis resistance PUR type UWR cast resin (containing the correct volume ready for mixing), packed in practical and easy-to-use two-chamber bags, transparent plastic shell, branch clamp HE 1/70/150, sealing tapes, protective gloves, assembly instructions

Optional accessory: Cleaner UNIVERSAL CLEANER 121 (see Accessories)

Type	L mm	D mm	H mm	max. Cable-Ø mm		Nominal cross section per conductor mm <sup>2</sup>			Art.-No.
				Main cable	Branch cable	Main cable SE	Main cable SM	Branch cable	
H 5-SYS 70-150	270	110	180	46	36	95 - 150	70 - 120	16 - 50	195816

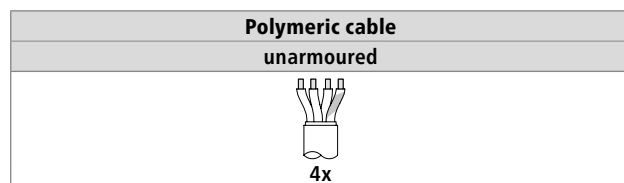





## P...EG

### Cast resin branch joint

with integrated strain relief, for polymeric cables and mass-impregnated paper cables, with cast resin EG

Universally suitable for branching polymeric cables insulated with PVC, PE, XLPE and paper (e.g. N(A)YY, N(A)KBA, GN-CLN, TT) with or without concentric conductor and mass-impregnated paper cables. Suitable for branch clamps on copper and aluminium conductors.

#### Characteristics

- High-quality brown shockproof plastic shell
- Compact design
- Integrated strain relief
- Large filler aperture to facilitate casting
- Resistant to chemical agents
- Resistant to alkaline earth elements
- Stabilized against UV rays
- Longitudinally and transversely water-tight
- High electrical insulating values
- High mechanical strength
- Ready for immediate operation
- Quick and easy assembly saves time and reduces costs

#### Application/Suitability

- Indoor
- Outdoor
- Underground
- Water
- Installation ducts

#### Voltage level

- $U_0/U_m$  (U<sub>m</sub>) 0.6/1 (1.2) kV

#### Test standards

- DIN EN 50393 (corresponds to VDE 0278)

#### Storage conditions/Shelf life

- Cast resin up to 40 months

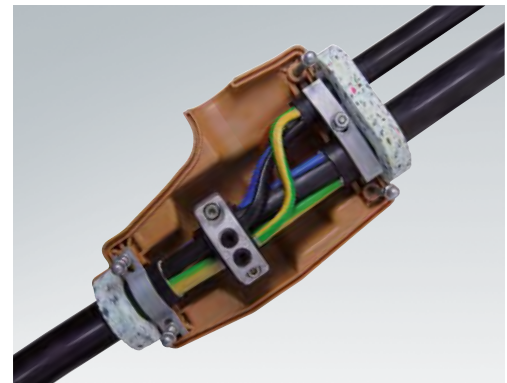

#### Dimensions

P 2 EG,  
P 2KP EG

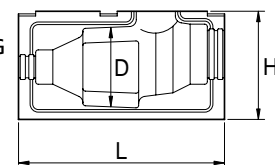

P 3 EG,  
PC 5 EG,  
PC 7 EG

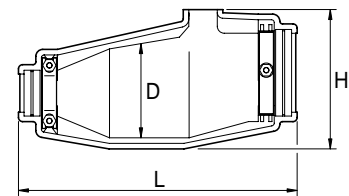

PD 5 EG

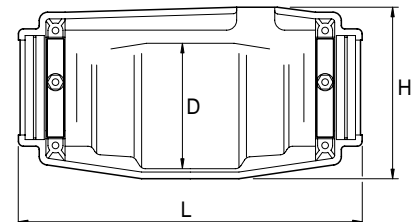

PB 4 EG,  
PBE 4 EG,  
PE 7 EG

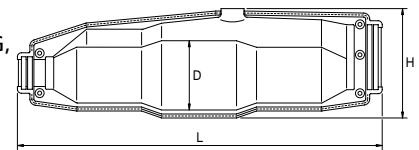

P 4 EG - P 7 EG

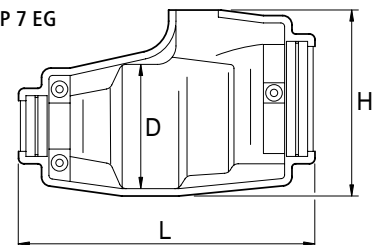

#### Scope of delivery

Hydrolysis resistance PUR type EG cast resin (containing the correct volume ready for mixing), packed in practical and easy-to-use two-chamber bags, sealing gaskets, plastic shell with integrated strain relief, hexagon head screws and nuts, assembly instructions

Optional accessory: Branch clamp HE 1/70/150 (see Connecting technology)  
Branch clamp KP (see Connecting technology)  
Cleaner UNIVERSAL CLEANER 121 (see Accessories)

Note: For branch joints sizes larger than P 5 EG, branch clamps HE 1/70/150 can be used (see Connecting technology).



→ Continued on the next page





→ Continuation

**P...EG Cast resin branch joint**

LOW VOLTAGE  
Cast resin technology

Mass-impregnated paper cable		Polymeric cable unarmoured	
 3x	 4x	 4x	

Type	L mm	D mm	H mm	max. Cable-Ø mm		Nominal cross section per conductor mm <sup>2</sup>				Art.-No.
				Main cable	Branch cable	Main cable	Branch cable	Main cable	Branch cable	
P 2 EG	240	90	127	13 - 25	13 - 25			2.5 - 16	2.5 - 16	127697
P 4 EG	302	113	200	28 - 45	21 - 34			50 - 95	16 - 35	127698
P 5 EG	325	135	200	37 - 54	20 - 36			95 - 150	16 - 50	127733
P 6 EG	432	135	210	44 - 59	28 - 45			150 - 185	50 - 95	127695
P 7 EG	442	150	245	40 - 59	40 - 59			120 - 185	120 - 150	127696
PD 5 EG	427	130	212	37 - 54	20 - 36			95 - 150	16 - 50	127701
P 3 EG	342	90	160	15 - 35	12 - 30	10 - 16	10 - 16	10 - 25	4 - 16	127703
PC 5 EG	392	130	210	35 - 54	20 - 36			95 - 185	16 - 50	127699
PC 7 EG	472	150	225	40 - 59	40 - 50			150 - 240	50 - 95	127700
PB 4 EG	532	120	200	30 - 50	27 - 44	95 - 150	95 - 150	95 - 150	50 - 95	127763
PE 7 EG	692	180	285	40 - 59	40 - 59			150 - 240	120 - 185	127709

Polymeric cable with concentric conductor	
 3x	 4x

Type	L mm	D mm	H mm	max. Cable-Ø mm		Nominal cross section per conductor mm <sup>2</sup>				Art.-No.
				Main cable	Branch cable	Main cable	Branch cable	Main cable	Branch cable	
P 2 EG	240	90	127	13 - 25	13 - 25					127697
P 4 EG	302	113	200	28 - 45	21 - 34					127698
P 5 EG	325	135	200	37 - 54	20 - 36					127733
P 6 EG	432	135	210	44 - 59	28 - 45					127695
P 7 EG	442	150	245	40 - 59	40 - 59					127696
PD 5 EG	427	130	212	37 - 54	20 - 36					127701
P 3 EG	342	90	160	15 - 35	12 - 30	10/10 - 16/16	4/4 - 16/16	10/10 - 16/16	4/4 - 16/16	127703
PC 5 EG	392	130	210	35 - 54	20 - 36	95/95 - 150/150	16/16 - 50/50	95/95 - 150/150	16/16 - 50/50	127699
PC 7 EG	472	150	225	40 - 59	40 - 50	150/150 - 185/185	50/50 - 95/95	150/150 - 185/185	50/50 - 95/95	127700
PB 4 EG	532	120	200	30 - 50	27 - 44		50/50 - 95/95		50/25 - 95/50	127763
PE 7 EG	692	180	285	40 - 59	40 - 59					127709



**P...GG** **NEW**

## Cast resin branch joint

with integrated strain relief, for polymeric cables and mass-impregnated paper cables, with cast resin GG (reduced hazard-class)

Universally suitable for branching polymeric cables insulated with PVC, PE, XLPE and paper (e.g. N(A)YY, N(A)KBA, GN-CLN, TT) with or without concentric conductor and mass-impregnated paper cables. Suitable for branch clamps on copper and aluminium conductors.

### Characteristics

- High-quality brown shockproof plastic shell
- Compact design
- Integrated strain relief
- Large filler aperture to facilitate casting
- Resistant to chemical agents
- Resistant to alkaline earth elements
- Stabilized against UV rays
- Longitudinally and transversely water-tight
- High electrical insulating values
- High mechanical strength
- Ready for immediate operation
- Quick and easy assembly saves time and reduces costs

### Application/Suitability

- Indoor
- Outdoor
- Underground
- Water
- Installation ducts

### Voltage level

- $U_0/U_m$  0.6/1 (1.2) kV

### Test standards

- DIN EN 50393 (corresponds to VDE 0278)

### Storage conditions/Shelf life

- Cast resin up to 24 months

### Scope of delivery

Hydrolysis resistance PUR type GG cast resin (containing the correct volume ready for mixing), packed in practical and easy-to-use two-chamber bags, sealing gaskets, plastic shell with integrated strain relief, hexagon head screws and nuts, assembly instructions

Optional accessory: Branch clamp HE 1/70/150 (see Connecting technology)  
Branch clamp KP (see Connecting technology)  
Cleaner UNIVERSAL CLEANER 121 (see Accessories)

Note: For branch joints sizes larger than P 5 GG, branch clamps HE 1/70/150 can be used (see Connecting technology).

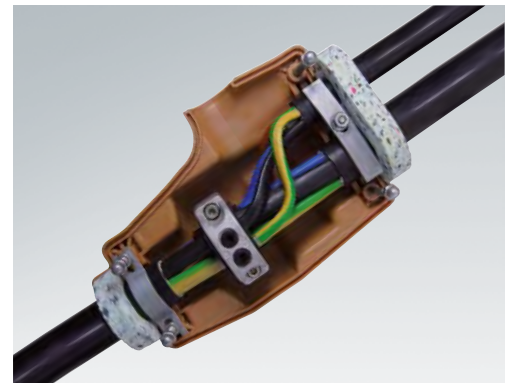

### Dimensions

P 2 GG

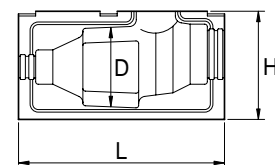

P 3 GG,  
PC 5 GG

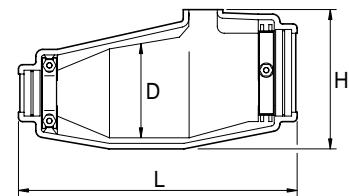

PB 4 GG,  
PE 7 GG

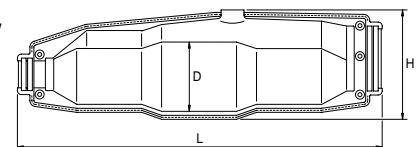

P 5 GG - P 7 GG

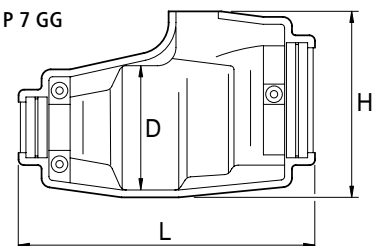



→ Continued on the next page





→ Continuation

**P...GG Cast resin branch joint**

LOW VOLTAGE  
Cast resin technology

Mass-impregnated paper cable		Polymeric cable unarmoured	
 3x	 4x	 4x	

Type	L mm	D mm	H mm	max. Cable-Ø mm		Nominal cross section per conductor mm <sup>2</sup>				Art.-No.
				Main cable	Branch cable	Main cable	Branch cable	Main cable	Branch cable	
P 2 GG	240	90	127	13 - 25	13 - 25			2.5 - 16	2.5 - 16	329587
P 5 GG	325	135	200	37 - 54	20 - 36			95 - 150	16 - 50	329567
P 6 GG	432	135	210	44 - 59	28 - 45			150 - 185	50 - 95	329569
P 7 GG	442	150	245	40 - 59	40 - 59			120 - 185	120 - 150	329588
P 3 GG	342	90	160	15 - 35	12 - 30	10 - 16	10 - 16	10 - 25	4 - 16	329589
PC 5 GG	392	130	210	35 - 54	20 - 36			95 - 185	16 - 50	335566
PB 4 GG	532	120	200	30 - 50	27 - 44	95 - 150	95 - 150	95 - 150	50 - 95	329572
PE 7 GG	692	180	285	40 - 59	40 - 59			150 - 240	120 - 185	335565

Polymeric cable with concentric conductor	
 3x	 4x

Type	L mm	D mm	H mm	max. Cable-Ø mm		Nominal cross section per conductor mm <sup>2</sup>				Art.-No.
				Main cable	Branch cable	Main cable	Branch cable	Main cable	Branch cable	
P 2 GG	240	90	127	13 - 25	13 - 25					329587
P 5 GG	325	135	200	37 - 54	20 - 36					329567
P 6 GG	432	135	210	44 - 59	28 - 45					329569
P 7 GG	442	150	245	40 - 59	40 - 59					329588
P 3 GG	342	90	160	15 - 35	12 - 30	10/10 - 16/16	4/4 - 16/16	10/10 - 16/16	4/4 - 16/16	329589
PC 5 GG	392	130	210	35 - 54	20 - 36	95/95 - 150/150	16/16 - 50/50	95/95 - 150/150	16/16 - 50/50	335566
PB 4 GG	532	120	200	30 - 50	27 - 44		50/50 - 95/95		50/25 - 95/50	329572
PE 7 GG	692	180	285	40 - 59	40 - 59					335565



## T Cast resin branch joint

for polymeric cables and conductors

Universally suitable for branching polymeric cables or conductors insulated with PVC, PE, XLPE and EPR (e.g. N(A)YY, NYM, TT) with or without concentric conductor. Suitable for branch clamps on copper and aluminium conductors.

### Characteristics

- Compact dimensions
- Splice area visible before casting
- High-quality transparent shockproof plastic shell
- Large filler aperture to facilitate casting
- Resistant to chemical agents
- Resistant to alkaline earth elements
- Stabilized against UV rays
- Longitudinally and transversely water-tight
- High electrical insulating values
- High mechanical strength
- Ready for immediate operation
- Quick and easy assembly saves time and reduces costs

### Application/Suitability

- Indoor
- Outdoor
- Underground
- Water
- Installation ducts

### Voltage level

- $U_0/U_m$  0.6/1 (1.2) kV

### Test standards

- DIN EN 50393 (corresponds to VDE 0278)

### Storage conditions/Shelf life

- Cast resin up to 40 months



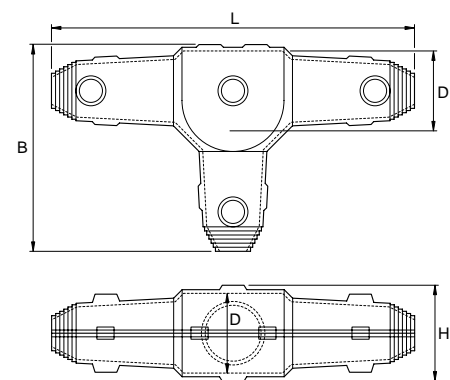

### Dimensions



### Scope of delivery

Hydrolysis resistance PUR type EG cast resin (containing the correct volume ready for mixing), packed in practical and easy-to-use two-chamber bags, transparent plastic shell, fill and air-release funnels, PVC insulation tape, protective gloves, assembly instructions

Optional accessory: Screw branch clamp AK (see Connecting technology)  
 Branch clamp KP (see Connecting technology)  
 Split bolt clamp FK (see Connecting technology)  
 Cleaner UNIVERSAL CLEANER 121 (see Accessories)

Polymeric cable													
unarmoured													
  													
Type	L mm	B mm	D mm	H mm	max. Cable-Ø mm	max. Nominal cross section per conductor mm <sup>2</sup>						Art.-No.	
						Main cable	Branch cable	Main cable	Branch cable	Main cable	Branch cable		
T 1	240	138	50	60	22	10	10	6	6	4	4	131149	
2	267	154	60	70	30	25	25	16	10	10	10	133024	
2.5	310	183	75	85	37	50	50	35	16	16	10	131855	
3	354	212	90	100	42	70	70	50	25	25	16	131151	
4	432	262	110	125	52	120	120	95	50	50		131778	
5	550	290	130	155	62	185	150	185	150	120		131854	

→ Continued on the next page



→ Continuation

## T Cast resin branch joint

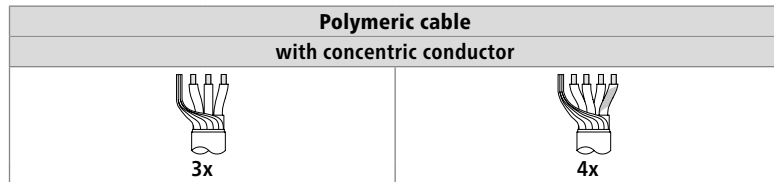

Type	L mm	B mm	D mm	H mm	max. Cable-Ø mm	max. Nominal cross section per conductor mm <sup>2</sup>				Art.-No.	
						Main cable	Branch cable	Main cable	Branch cable		
T	1	240	138	50	60	22	6/6	6/6			131149
	2	267	154	60	70	30	16/16	10/10	16/16	16/16	133024
	2.5	310	183	75	85	37	35/35	16/16	35/16	25/16	131855
	3	354	212	90	100	42	50/50	25/25	50/25	35/16	131151
	4	432	262	110	125	52	95/95	50/50	95/50	70/35	131778
	5	550	290	130	155	62	185/185	70/70	150/70	95/50	131854



## T...V AK

### Cast resin branch joint

with screw branch clamps, for polymeric cables and conductors

Universally suitable for branching polymeric cables or conductors insulated with PVC, PE, XLPE and EPR (e.g. N(A)YY, NYM, TT) with or without concentric conductor. With one-core branch clamps, suitable for copper and aluminium conductors.

#### Characteristics

- Compact dimensions
- Splice area visible before casting
- High-quality transparent shockproof plastic shell
- Large filler aperture to facilitate casting
- Resistant to chemical agents
- Resistant to alkaline earth elements
- Stabilized against UV rays
- Longitudinally and transversely water-tight
- High electrical insulating values
- High mechanical strength
- Ready for immediate operation
- Quick and easy assembly saves time and reduces costs

#### Application/Suitability

- Indoor
- Outdoor
- Underground
- Water
- Installation ducts

#### Voltage level

- $U_0/U_m$  (U<sub>m</sub>) 0.6/1 (1.2) kV

#### Test standards

- DIN EN 50393 (corresponds to VDE 0278)

#### Storage conditions/Shelf life

- Cast resin up to 40 months

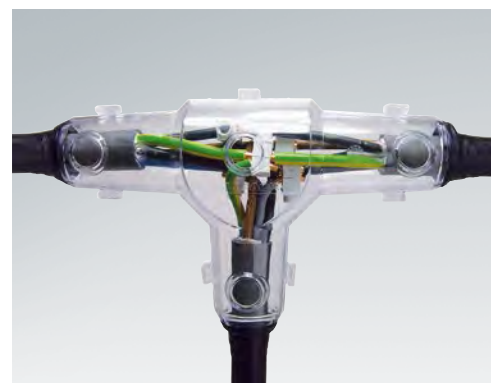

#### Dimensions

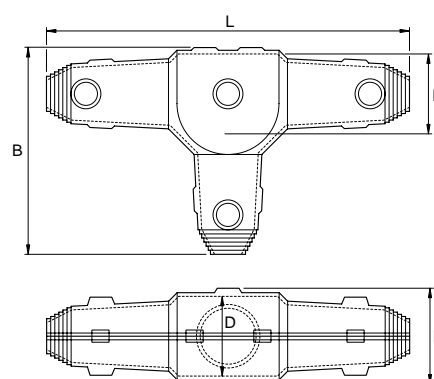

#### Scope of delivery

Hydrolysis resistance PUR type EG cast resin (containing the correct volume ready for mixing), packed in practical and easy-to-use two-chamber bags, transparent plastic shell, fill and air-release funnels, screw branch clamps, PVC insulation tape, protective gloves, assembly instructions

Optional accessory: Cleaner UNIVERSAL CLEANER 121 (see Accessories)

Type	L mm	B mm	D mm	H mm	max. Cable-Ø mm	Polymeric cable unarmoured				Art.-No.
						4x		5x		
						Nominal cross section per conductor mm <sup>2</sup>				
Main cable	Branch cable	Main cable	Branch cable							
T 1 V AK	240	138	50	60	22	1.5 - 6	1.5 - 6	1.5 - 6	1.5 - 6	345343
T 2 V AK	267	154	60	70	30	4 - 16	4 - 16	4 - 16	4 - 16	345344
T 2.5 V AK	310	183	75	85	37	6 - 25	6 - 16	6 - 25	6 - 16	345345



## Y

**Cast resin branch joint**

for polymeric cables and conductors

Universally suitable for branching polymeric cables or conductors insulated with PVC, PE, XLPE and EPR (e.g. N(A)YY, NYM, TT) with or without concentric conductor. Suitable for branch clamps on copper and aluminium conductors.

**Characteristics**

- Compact dimensions
- Splice area visible before casting
- High-quality transparent shockproof plastic shell
- Large filler aperture to facilitate casting
- Resistant to chemical agents
- Resistant to alkaline earth elements
- Stabilized against UV rays
- Longitudinally and transversely water-tight
- High electrical insulating values
- High mechanical strength
- Ready for immediate operation
- Quick and easy assembly saves time and reduces costs

**Application/Suitability**

- Indoor
- Outdoor
- Underground
- Water
- Installation ducts

**Voltage level**

- $U_0/U_m$  0.6/1 (1.2) kV

**Test standards**

- DIN EN 50393 (corresponds to VDE 0278)

**Storage conditions/Shelf life**

- Cast resin up to 40 months

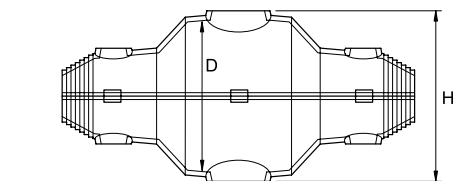
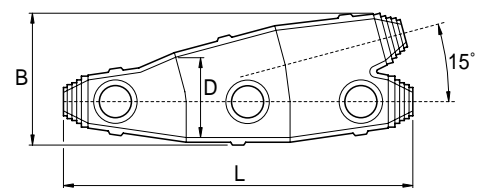
**Dimensions**

Y 00 - Y 2, Y 3.5, Y 5, Y 6

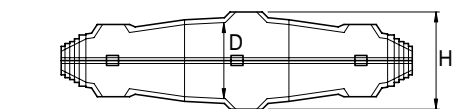
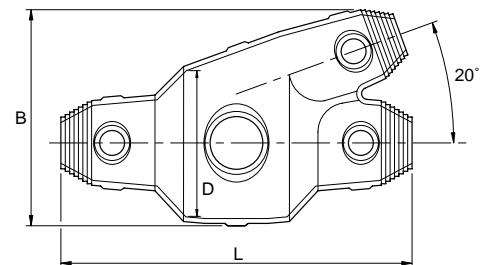

Y 3, Y 4, Y 4.5

**Scope of delivery**

Hydrolysis resistance PUR type EG cast resin (containing the correct volume ready for mixing), packed in practical and easy-to-use two-chamber bags, transparent plastic shell, closing stops, fill and air-release funnels, PVC insulation tape, protective gloves, assembly instructions

Optional accessory: Screw branch clamp AK (see Connecting technology)  
Branch clamp KP (see Connecting technology)  
Branch clamp HE 1/70/150 (see Connecting technology)  
Split bolt clamp FK (see Connecting technology)  
Cleaner UNIVERSAL CLEANER 121 (see Accessories)

→ Continued on the next page





→ Continuation

## Y Cast resin branch joint

LOW VOLTAGE  
Cast resin technology

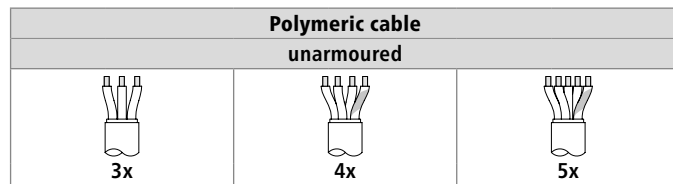

Type	L mm	B mm	D mm	H mm	max. Cable-Ø mm		max. Nominal cross section per conductor mm <sup>2</sup>						Art.-No.	
					Main cable	Branch cable	Main cable	Branch cable	Main cable	Branch cable	Main cable	Branch cable		
Y	00	150	75	38	50	19	19	4	2.5	4	2.5	4	2.5	133841
	0	185	80	45	55	17	17	6	6	6	6	6	6	152932
	1	240	110	60	70	22	22	10	10	10	10	10	10	124730
	2	285	120	65	75	34	30	25	25	25	25	25	25	147533
	3	240	145	100	110	42	37	50	25	50	35	25	25	131123
	3.5	300	150	110	120	54	38	70	25	50	35	35	35	131118
	4	285	170	110	120	53	37	95	35	95	50	50	35	124763
	4.5	335	193	120	130	56	42	150	70	150	70	120	70	131119
5	382	220	140	150	62	52	240	150	240	95	150	95	157645	
6	570	275	180	190	90	80	300	240	300	185	150	150	131126	

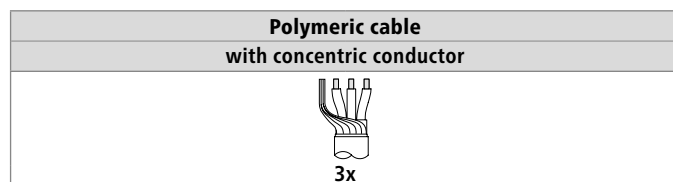

Type	L mm	B mm	D mm	H mm	max. Cable-Ø mm		max. Nominal cross section per conductor mm <sup>2</sup>		Art.-No.	
					Main cable	Branch cable	Main cable	Branch cable		
Y	00	150	75	38	50	19	19			133841
	0	185	80	45	55	17	17	6/6	6/6	152932
	1	240	110	60	70	22	22	10/10	10/10	124730
	2	285	120	65	75	37	33	16/16	10/10	147533
	3	240	145	100	110	42	37	25/25	16/16	131123
	3.5	300	150	110	120	54	38	35/35	25/25	131118
	4	285	170	110	120	53	37	70/70	25/25	124763
	4.5	335	193	120	130	56	42	120/120	95/95	131119
5	382	220	140	150	62	52	150/150	95/95	157645	
6	570	275	180	190	90	80	240/120	185/95	131126	



## Y...V AK

### Cast resin branch joint

with screw branch clamps, for polymeric cables and conductors

Universally suitable for branching polymeric cables or conductors insulated with PVC, PE, XLPE and EPR (e.g. N(A)YY, NYM, TT) with or without concentric conductor. With one-core branch clamps, suitable for copper and aluminium conductors.

#### Characteristics

- Compact dimensions
- Splice area visible before casting
- High-quality transparent shockproof plastic shell
- Large filler aperture to facilitate casting
- Resistant to chemical agents
- Resistant to alkaline earth elements
- Stabilized against UV rays
- Longitudinally and transversely water-tight
- High electrical insulating values
- High mechanical strength
- Ready for immediate operation
- Quick and easy assembly saves time and reduces costs

#### Application/Suitability

- Indoor
- Outdoor
- Underground
- Water
- Installation ducts

#### Voltage level

- $U_0/U_m$  0.6/1 (1.2) kV

#### Test standards

- DIN EN 50393 (corresponds to VDE 0278)

#### Storage conditions/Shelf life

- Cast resin up to 40 months

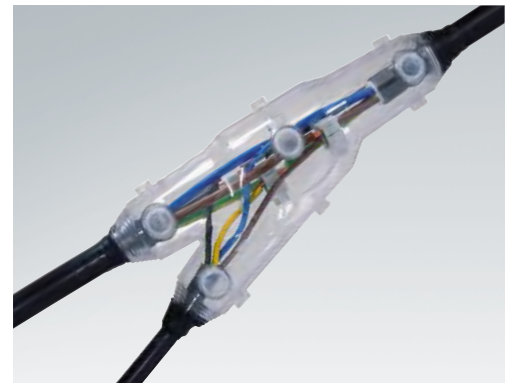

#### Dimensions

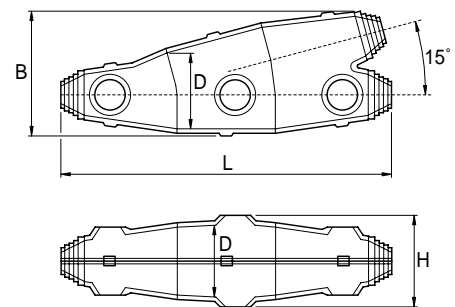

#### Scope of delivery

Hydrolysis resistance PUR type EG cast resin (containing the correct volume ready for mixing), packed in practical and easy-to-use two-chamber bags, transparent plastic shell, closing stops, fill and air-release funnels, screw branch clamps, PVC insulation tape, protective gloves, assembly instructions

Optional accessory: Cleaner UNIVERSAL CLEANER 121 (see Accessories)

Polymeric cable	
unarmoured	
4x	5x

Type	L mm	B mm	D mm	H mm	max. Cable-Ø mm	Nominal cross section per conductor mm <sup>2</sup>				Art.-No.	
						Main cable	Branch cable	Main cable	Branch cable		
Y	0 V AK	185	80	45	55	17	1.5 - 4	1.5 - 4	1.5 - 4	1.5 - 4	299001
	1 V AK	240	110	60	70	22	2.5 - 6	2.5 - 6	2.5 - 6	2.5 - 6	299002
	2 V AK	285	120	65	75	33	4 - 16	4 - 16	4 - 16	4 - 16	299003



## YCP

### Cast resin branch joint

for polymeric cables and conductors

Suitable for branching the 1-core cables or conductors, e.g. wires for cathodic corrosion protection from chemical and electrochemical reactions in underground area and under water. Pipes, warehouse containers, electric supply lines and other metal constructions are economically and effectively protected against passive corrosion (polymeric casings, mastic glass fibre casings). Suitable for branch clamps on copper and aluminium conductors.

#### Characteristics

- Compact dimensions
- Splice area visible before casting
- High-quality transparent shockproof plastic shell
- Large filler aperture to facilitate casting
- Resistant to chemical agents
- Resistant to alkaline earth elements
- Stabilized against UV rays
- Longitudinally and transversely water-tight
- High electrical insulating values
- High mechanical strength
- Ready for immediate operation
- Quick and easy assembly saves time and reduces costs

#### Application/Suitability

- Indoor
- Outdoor
- Underground
- Water
- Installation ducts

#### Voltage level

- $U_0/U_m$  0.6/1 (1.2) kV

#### Test standards

- DIN EN 50393 (corresponds to VDE 0278)

#### Storage conditions/Shelf life

- Cast resin up to 40 months



#### Dimensions

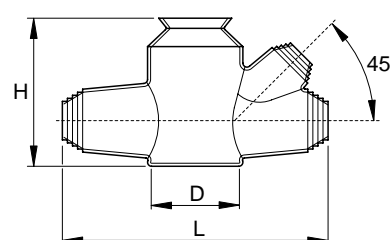

#### Scope of delivery

Hydrolysis resistance PUR type EG cast resin (containing the correct volume ready for mixing), packed in practical and easy-to-use two-chamber bags, transparent plastic shell, closing stops, PVC insulation tape, protective gloves, assembly instructions

Optional accessory: Screw branch clamp AK (see Connecting technology)  
Split bolt clamp FK (see Connecting technology)  
Cleaner UNIVERSAL CLEANER 121 (see Accessories)

Type	L mm	B mm	D mm	H mm	max. Cable-Ø mm		Nominal cross section per conductor mm <sup>2</sup>		Art.-No.
					Main cable	Branch cable	Main cable	Branch cable	
YCP	135	48	44	75	23	20	10 - 50	4 - 50	124683



**D1**

**Cast resin branch / straight-through joint**

particularly for small cross sections for polymeric cables and conductors, control cables and signal cables

The parallel-branch joint (dual connection joint) is suitable for branching polymeric cables or conductors mainly used for 1-core special cables for airport runways lighting. Suitable for compression connectors on copper conductors.

**Characteristics**

- Compact dimensions
- Splice area visible before casting
- High-quality transparent shockproof plastic shell
- Large filler aperture to facilitate casting
- Resistant to chemical agents
- Resistant to alkaline earth elements
- Stabilized against UV rays
- Longitudinally and transversely water-tight
- High electrical insulating values
- High mechanical strength
- Ready for immediate operation
- Quick and easy assembly saves time and reduces costs

**Application/Suitability**

- Indoor
  - Outdoor
  - Underground
  - Water
  - Installation ducts
- Voltage level**
- $U_0/U_m$  0.6/1 (1.2) kV
- Test standards**
- DIN EN 50393 (corresponds to VDE 0278)
- Storage conditions/Shelf life**
- Cast resin up to 40 months



Dimensions

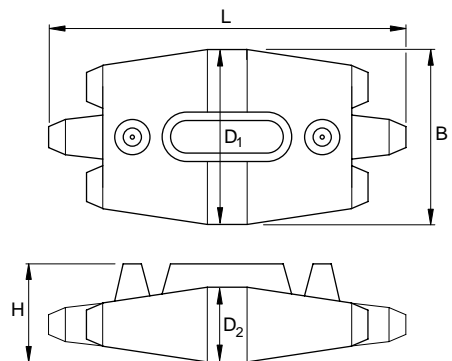

**Scope of delivery**

Cover, hydrolysis resistance PUR type EG cast resin (containing the correct volume ready for mixing), packed in practical and easy-to-use two-chamber bags, transparent plastic shell, PVC insulation tape, protective gloves, assembly instructions

Optional accessory: Compression connectors (see Connecting technology)  
Cleaner UNIVERSAL CLEANER 121 (see Accessories)

							Polymeric cable					
							unarmoured					
							1x		4x			
Type	L mm	B mm	D1 mm	D2 mm	H mm	max. Cable-Ø mm	Nominal cross section per conductor mm <sup>2</sup>				Art.-No.	
D 1	185	90	84	30	48	16	6		2.5		124685	

							Control and signal cable					
							0.6 mm <sup>2</sup>   0.8 mm <sup>2</sup>   0.75 mm <sup>2</sup>   1.5 mm <sup>2</sup>					
Type	L mm	B mm	D1 mm	D2 mm	H mm	max. Cable-Ø mm	Number of wire pairs		Number of conductors		Art.-No.	
D 1	185	90	84	30	48	16	6 - 10		6 - 6		124685	



# Universal Box KG

## Connection and branch box

with clamps

The connection and branch box combines the advantages of a traditional box with the well-known professional cast resin technology. Complex connections in a very small volume can be done with this universal box. The system guarantees an absolute waterproof protection, excluding all condensation risks.

### Characteristics

- Practical box with membran entries
- For conductor cross-sections of 0.5 - 2.5 mm<sup>2</sup>
- Salt water-resistant
- Stabilized against UV rays
- High flexibility due to removable transparent cast resin
- Cable retaining rings for additional stabilisation of the cable
- Withstands long-term exposure to moisture

### Application/Suitability

- Outdoor
- Indoor areas (also with high humidity level)

### Voltage level

- 230/440 V

### Test standards

- DIN EN 50393 (corresponds to VDE 0278)

### Storage conditions/Shelf life

- Cast resin up to 24 months



### Dimensions

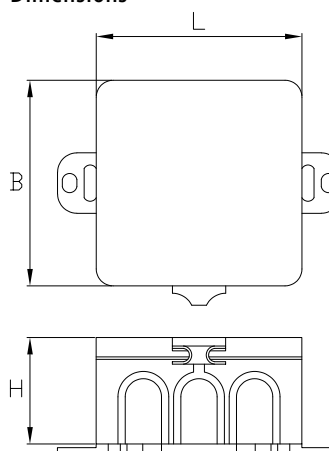

### Scope of delivery

286 ml hydrolysis resistance PUR type KG cast resin (containing the correct volume ready for mixing), packed in practical and easy-to-use two-chamber bags, box with membran entries, 5 clamps 5-pole 0.5 - 2.5 mm<sup>2</sup>, 12 cable retaining rings CP-Z1, funnel for easy vertical filling, cleaning tissue, emery cloth, assembly instructions

Optional accessory: Cleaner UNIVERSAL CLEANER 121 (see Accessories)

Note: Type KG cast resin refills may be ordered separately.

Type	L mm	B mm	H mm	max. Cable-Ø mm	Polymeric cable		Art.-No.
					unarmoured		
					Nominal cross section per conductor mm <sup>2</sup>		
Universal Box KG	286 ml	85	85	45	15	0.5 - 2.5	221122

LOW VOLTAGE  
Cast resin technology



**EG**

## Two-component PUR cast resin

universal

Cast resin EG is suitable for the following types of cables: Low voltage polymeric-insulated and mass-impregnated paper cables up to 1 kV, polymeric-insulated and mass-impregnated paper telecommunication and signal cables and medium voltage cables (as mechanical protection and protection against moisture).

### Characteristics

- Two-component PUR cast resin
- In practical and easy-to-use two-chamber bags
- Favourable flow properties
- High hydrolysis resistance
- Resistant to alkaline earth elements
- Stabilized against UV rays
- Halogen-free
- Not harmful to the environment
- Flexibility ensures mechanical stress absorption
- No fracturing under electrical stress
- No fracturing under mechanical tension
- Excellent adhesion to all cable materials
- Low hardening temperature

### Test standards

- DIN VDE 0278-631-1
- Storage conditions/Shelf life**
- In aluminium bag 40 months at ambient temperatures between 15 °C and 35 °C



### Scope of delivery

1 PU

Note: Other sizes available on request.

Type	Content ml	Art.-No.
80	80	134999
143	143	124909
286	286	124986
370	370	124962
464	464	124989
730	730	124990
1000	1000	124992
1150	1150	124901
1500	1500	124991
2000	2000	132206

→ Continued on the next page



→ Continuation

**EG Two-component PUR cast resin**

Technical data	Value
Flash point of cast resin component (open cup)	> 200 °C
Flash point of reactant (open cup)	> 200 °C
Processing time (pot life) of 300 ml mixture at	
5 °C	40 minutes
23 °C	23 minutes
35 °C	15 minutes
max. Reaction temperature	80 °C
Total volume shrinkage during curing	4.0 %
Density	1.10 g/cm <sup>3</sup>
Impact strength	> 10 kJ/m <sup>2</sup>
Hardness	55 Shore D
Combustibility	Category 2C
Water absorption in warm water (42 d at 50 °C)	
Electrolytic corrosion	A 1
1 minute test voltage at	
23 °C	> 20 kV
80 °C	> 20 kV
Dielectric dissipation factor at	
23 °C and 1 kHz	0.05
23 °C and 50 Hz	0.08
Dielectric constant at	
23 °C and 1 kHz	5.3
23 °C and 50 Hz	5.1
Tracking resistance	KA 3c
Operating temperature range	-40 °C up to +105 °C

**GG** **NEW**

## Two-component PUR cast resin

reduced hazard-class

Cast resin GG is a special development to fulfill reduced hazard-classification. It's labelling identification, according to the CLP-Regulation (EC) No. 1272/2008, does not contain the H351 statement. The cast resin GG has similar properties as the known polyurethane cast resins. Cast resin GG is suitable for low voltage polymeric-insulated and mass-impregnated paper cables up to 1 kV.

### Characteristics

- Two-component PUR cast resin
- In practical and easy-to-use two-chamber bags
- Favourable flow properties
- High hydrolysis resistance
- Resistant to alkaline earth elements
- Stabilized against UV rays
- Halogen-free
- Not harmful to the environment
- Flexibility ensures mechanical stress absorption
- No fracturing under electrical stress
- No fracturing under mechanical tension
- Excellent adhesion to all cable materials
- Low hardening temperature
- Reduced hazardous labelling identification according to the CLP-Regulation (EC) No. 1272/2008

### Test standards

- DIN VDE 0278-631-1
- Storage conditions/Shelf life**
- In aluminium bag 24 months at ambient temperatures between 15 °C and 35 °C



### Scope of delivery

1 PU

Note: Other sizes available on request.

Type	Content ml	Art.-No.
GG	1700	335750
	2150	317353

Technical data	Value
Flash point of cast resin component (open cup)	> 200 °C
Flash point of reactant (open cup)	> 200 °C
Processing time (pot life) 300 ml mixture at	
5 °C	68 minutes
23 °C	24 minutes
35 °C	15 minutes
max. Reaction temperature	60 °C
Total volume shrinkage during curing	< 6.0 %
Density	1.32 g/cm <sup>3</sup>
Impact strength	> 10 kJ/m <sup>2</sup>
Hardness	30 Shore D
Operating temperature range	-40 °C up to +90 °C





## KG

### Two-component PUR cast resin

removable

Cast resin KG is 2-component polyurethane resin (PUR) specially developed for casting of cable connections. The transparent removable „crumble“ cast resin allows a visual inspection even after the casting. The connection is accessible at any time by removing the cast resin. Typical application areas: cable branch-off cabinet, connection boxes, telecommunication cable connections, electronic components etc.

#### Characteristics

- Two-component PUR cast resin
- In practical and easy-to-use two-chamber bags
- Favourable flow properties
- High hydrolysis resistance
- Remains transparent after hardening
- No fracturing under electrical stress
- Excellent adhesion to all cable materials
- Low hardening temperature

#### Note

- Connection requires mechanical tension relief due to the flexibility of the resin.

#### Test standards

- DIN VDE 0278-631-1

#### Storage conditions/Shelf life

- In aluminium bag 24 months at ambient temperatures between 15 °C and 35 °C



#### Scope of delivery

1 PU

Note: Other sizes available on request.

Type	Content ml	Art.-No.
KG	143	125165
	286	125166
	730	125167
	2000	255159

Technical data	Value
Density	1.00 g/m <sup>3</sup>
Hardness	10 Shore A
Elongation at break	10 %
Water absorption in warm water (42 d at 50 °C)	188 mg
Water absorption in cold water (24 h at 23 °C)	30 mg
1 minute test voltage at 23 °C	> 20 kV
80 °C	> 10 kV
Tensile strength	0.7 N/mm <sup>2</sup>
Specific volume resistivity	2 x 10 <sup>10</sup> Ω x cm
Viscosity (20 °C)	1000 mPa x s



**FG**

## Two-component PUR cast resin

flexible

Cast resin FG is suitable for repairing damaged cable-sheaths and for connecting flexible cables. It provides an excellent resistance to abrasion.

**Characteristics**

- Two-component PUR cast resin
- In practical and easy-to-use two-chamber bags
- Favourable flow properties
- High hydrolysis resistance
- Halogen-free
- Not harmful to the environment
- Resin remains highly flexible after hardening
- Flexibility ensures mechanical stress absorption
- No fracturing under electrical stress
- No fracturing under mechanical tension
- Excellent adhesion to all cable materials
- Low hardening temperature

**Test standards**

- DIN VDE 0278-631-1

**Storage conditions/Shelf life**

- In aluminium bag 24 months at ambient temperatures between 15 °C and 35 °C



**Scope of delivery**

1 PU

Note: Other sizes available on request.

Type	Content ml	Art.-No.
FG	143	135534
	286	125153
	464	125154
	730	131233
	1000	125155

→ Continued on the next page



→ Continuation

**FG Two-component PUR cast resin**

Technical data	Value
Flash point of cast resin component (open cup)	> 200 °C
Flash point of reactant (open cup)	> 200 °C
Processing time (pot life) 300 ml mixture at	
5 °C	21 minutes
23 °C	17 minutes
35 °C	12 minutes
max. Reaction temperature	60 °C
Total volume shrinkage during curing	6.0 %
Density	1.10 g/cm <sup>3</sup>
Hardness	50 Shore A
Elongation at break	250 %
Water absorption in warm water (42 d at 50 °C)	600 mg
1 minute test voltage at	
23 °C	> 20 kV
80 °C	> 10 kV
Dielectric dissipation factor at	
23 °C and 50 Hz	0.20
50 °C and 50 Hz	1.40
Dielectric constant at	
23 °C and 50 Hz	7.4
50 °C and 50 Hz	8.9
Tracking resistance	KA 3c



## UG

### Two-component PUR cast resin

flame retardant

Cast resin UG meets the higher fire protection requirements and was specially developed for use in mining. It meets the requirements for cast resin moulding according to DIN VDE 0291 Section 2 on filling the cable sets or parts thereof for the following types of cables: Power cables with a nominal voltage up to 1 kV - GNH, power cables with a nominal voltage up to 10 kV - GMH and telecommunication and signal cables - GFH.

#### Characteristics

- Two-component PUR cast resin
- In practical and easy-to-use two-chamber bags
- Favourable flow properties
- Fast-hardening
- High hydrolysis resistance
- Resistant to chemical agents
- Resistant to alkaline earth elements
- Stabilized against UV rays
- Halogen-free
- Flame retardant
- Not harmful to the environment
- Low smoke emission in case of fire
- No fracturing under electrical stress
- No fracturing under mechanical tension
- Excellent adhesion to all cable materials

#### Test standards

- Flame retardation in accordance with DIN VDE 0472 Section 804, test typ C
- Properties of insulation against flames in accordance with DIN VDE 0472 Section 814
- Corrosiveness of combustion gases in accordance with DIN VDE 0472 Section 813
- DIN VDE 0278-631-1

#### Storage conditions/Shelf life

- In aluminium bag 24 months at ambient temperatures between 15 °C and 35 °C



#### Scope of delivery

1 PU

Note: Other sizes available on request.

Type	Content ml	Art.-No.
80	80	125286
143	143	125287
286	286	125288
464	464	125289
730	730	125290
1000	1000	125291
1850	1850	131331
2000	2000	135533

→ Continued on the next page



→ Continuation

## UG Two-component PUR cast resin

Technical data	Value
Flash point of cast resin component (open cup)	> 200 °C
Flash point of reactant (open cup)	> 200 °C
Processing time (pot life) 300 ml mixture at	
5 °C	23 minutes
23 °C	16 minutes
35 °C	12 minutes
max. Reaction temperature	78 °C
Total volume shrinkage during curing	2.5 %
Density	1.40 g/cm <sup>3</sup>
Impact strength	> 20 kJ/m <sup>2</sup>
Hardness	80 Shore D
Combustibility	Category 2A
Water absorption in warm water (42 d at 50 °C)	250 mg
Water absorption in cold water (24 h at 23 °C)	18 mg
Electrolytic corrosion	A 1.2
1 minute test voltage at	
23 °C	38 kV
80 °C	35 kV
Dielectric dissipation factor at	
23 °C and 1 kHz	0.02
23 °C and 50 Hz	0.03
50 °C and 50 Hz	0.06
80 °C and 50 Hz	0.15
Dielectric constant at	
23 °C and 1 kHz	4.1
23 °C and 50 Hz	4.3
50 °C and 50 Hz	5.5
80 °C and 50 Hz	7.2
Tracking resistance	KA 3c



## UWR

### Two-component PUR cast resin

low reactivity to water

Cast resin UWR has been specially developed for filling the cable joints exposed to high levels of humidity. It is characterised by its resistance to water in the liquid and in the solid state and is suitable for the encapsulation which are exposed to high levels of humidity for the following cable types: low voltage polymeric-insulated and mass-impregnated paper cables up to 1 kV

#### Characteristics

- Two-component PUR cast resin
- In practical and easy-to-use two-chamber bags
- Favourable flow properties
- High hydrolysis resistance
- Halogen-free
- Not harmful to the environment
- No fracturing under electrical stress
- No fracturing under mechanical tension
- Excellent adhesion to all cable materials

#### Test standards

- DIN VDE 0278-631-1

#### Storage conditions/Shelf life

- In aluminium bag 24 months at ambient temperatures between 15 °C and 35 °C



#### Scope of delivery

1 PU

Note: Other sizes available on request.

Type	Content ml	Art.-No.
143	143	139163
286	286	138162
464	464	148876
650	650	199362
UWR 1175	1175	137406
1350	1350	137358
1500	1500	137712
1850	1850	163053
2000	2000	137877

→ Continued on the next page



→ Continuation

**UWR Two-component PUR cast resin**

Technical data	Value
Flash point of cast resin component (open cup)	140 °C
Processing time (pot life) 300 ml mixture at	
5° C	30 minutes
23 °C	15 minutes
35 °C	8 minutes
max. Reaction temperature	88 °C
Total volume shrinkage during curing	4.2 %
Density	1.20 g/cm <sup>3</sup>
Impact strength	> 28 kJ/m <sup>2</sup>
Hardness	60 Shore D
Elongation at break	40 %
Effect of long-term warm storage on impact strength (38 d)	15 kJ/m <sup>2</sup>
Tear resistance	16 N/mm <sup>2</sup>
Tensile strength	15 N/mm <sup>2</sup>
Residual deformation (after 24 h)	0.4 %
Pressure required for 30 % deformation	27 N/mm <sup>2</sup>
Curing under water	< 10 ml glass
Hydrolysis resistance after water immersion (28 d at 70 °C)	passed
Physical structure	passed (homogeneous and bubble-free)



## WG

### Two-component PUR cast resin

removable

The unfilled thin two-component polyurethane cast resin (PUR) WG was particularly developed for cable joints. The hardened moulding material is permanently elastic and can be removed at any time with simple tools.

#### Characteristics

- Two-component PUR cast resin
- In practical and easy-to-use two-chamber bags
- Favourable flow properties
- High hydrolysis resistance
- Halogen-free
- Not harmful to the environment
- No fracturing under electrical stress
- Excellent adhesion to all cable materials
- Low hardening temperatur
- Permanently flexible after hardening

#### Note

- Connection requires mechanical tension relief due to the flexibility of the resin e.g. by means of a mechanically stable joint housing.

#### Test standards

- DIN VDE 0278-631-1

#### Storage conditions/Shelf life

- In aluminium bag 18 months at ambient temperatures between 15 °C and 35 °C



#### Scope of delivery

1 PU

Note: Other sizes available on request.

Type	Content ml	Art.-No.
WG 286	286	125202
WG 464	464	125203
WG 730	730	125204
WG 1000	1000	125205
WG 1150	1150	125206
WG 1500	1500	125207
WG 2000	2000	125208
WG 2200	2200	125209

→ Continued on the next page





→ Continuation

**WG Two-component PUR cast resin**

Technical data	Value
Flash point of cast resin component (open cup) Flash point of reactant (open cup)	200 °C
Processing time (pot life) 300 ml mixture at 5 °C 23 °C 35 °C	33 minutes 24 minutes 21 minutes
max. Reaction temperature	60 °C
Total volume shrinkage during curing	1.2 %
Density	1.10 g/cm <sup>3</sup>
Hardness	44 Shore A
Elongation at break	60 %
Tensile strength	0.6 N/mm <sup>2</sup>
Tracking resistance	KA 3c
Water absorption in warm water (42 d at 50 °C)	450 mg
Electrolytic corrosion	A 1.2
1 minute test voltage at 23 °C 80 °C	> 20 kV > 10 kV
Dielectric dissipation factor at 23 °C and 50 Hz	0.04
Dielectric constant at 23 °C and 50 Hz	5.7



## Gel technology



Straight-through joints ..... 116



Branch joints ..... 118



Casting compounds ..... 119



**EASYCELL®**

**Gel straight-through joint**

with connection block

Universally suitable for connecting all polymeric cables and conductors (e.g. N(A)YY, NYM, H05), cross section range from 1.5 mm<sup>2</sup> to 25 mm<sup>2</sup>. Suitable for aluminium and copper conductors.

**Characteristics**

- Connector area completely sealed by gel
- Re-accessible and ready for immediate operation
- Multi range one-piece connection block
- High-quality shockproof plastic shells
- Non-labelled and non-toxic
- Quick and easy assembly

**Application/Suitability**

- Indoor
- Outdoor
- Underground
- Water (according to test standard)

**Voltage level**

- U<sub>0</sub>/U (U<sub>m</sub>) 0.6/1 (1.2) kV

**Test standards**

- Type-tested according EN 50393

**Storage conditions/Shelf life**

- Unlimited shelf life



**Dimensions**

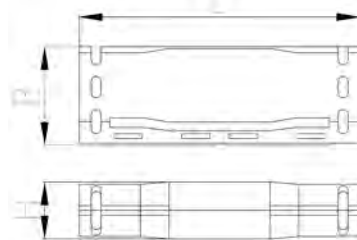

**Scope of delivery**

EASY 2 V: Gel straight-through joint, lustre terminal, cable ties

EASY 3 V - 5 V: Gel straight-through joint, connection block, allen key, cable ties

Optional accessory: EASYCELL® Strain relief, available for connecting joints from 6 mm<sup>2</sup> to 25 mm<sup>2</sup> (EASY 4 V and EASY 5 V)

					Polymeric cable unarmoured			
					3x	4x	5x	
Type	L mm	B mm	H mm	Nominal cross section per conductor mm <sup>2</sup>			Art.-No.	
EASY	2 V	86	47	27	1.5 - 2.5			320436
	3 V	146	55	35	1.5 - 6	1.5 - 6	1.5 - 6	309445
	4 V	180	69	40	6 - 16	6 - 16	6 - 16	309446
	5 V	240	75	44	16 - 25	16 - 25	16 - 25	309447



**EASYCELL®**  
**Strain relief**

for gel straight-through joints EASY 4 V and EASY 5 V

For the application with high mechanical loads and forces.

**Characteristics**

- Quick and easy assembly

**Application/Suitability**

- Mechanical protection

**Scope of delivery**

Strain relief



Type	Art.-No.
Strain relief	310553



**EASYCELL®**

**Gel branch joint**

with branch-off block

Universally applicable for branching all polymeric cables and conductors (e.g. N(A)YY, NYM, H05) cross section range from 6 mm<sup>2</sup> to 35 mm<sup>2</sup>. Suitable for aluminium and copper conductors.

**Characteristics**

- Connector area completely sealed by gel
- Re-accessible and ready for immediate operation
- Multi range one-piece branch-off block
- High-quality shockproof plastic shells
- Non-labelled and non-toxic
- Quick and easy assembly

**Application/Suitability**

- Indoor
- Outdoor
- Underground
- Water (according to test standard)

**Voltage level**

- U<sub>0</sub>/U (U<sub>m</sub>) 0.6/1 (1.2) kV

**Test standards**

- Type-tested according EN 50393

**Storage conditions/Shelf life**

- Unlimited shelf life

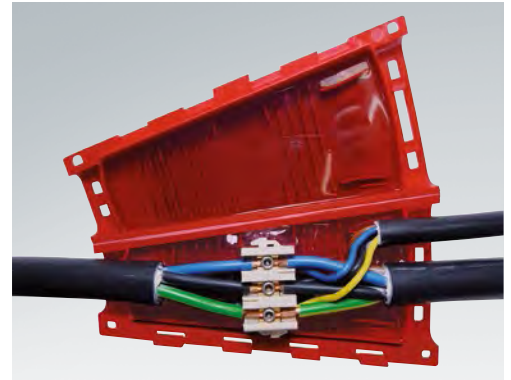

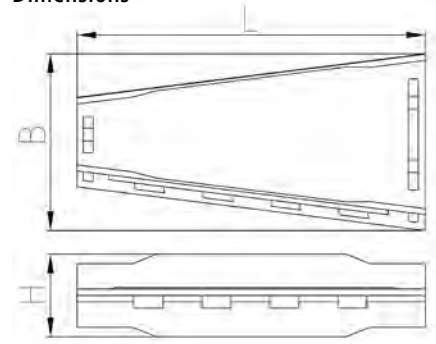

**Dimensions**



**Scope of delivery**

Gel branch joint, branch-off block, allen key, cable ties

Polymeric cable unarmoured												
 3x  4x  5x												
Type	L mm	B mm	H mm	Nominal cross section per conductor mm <sup>2</sup>						Art.-No.		
				Main cable	Branch cable	Main cable	Branch cable	Main cable	Branch cable			
EASY	6 V	220	110	53	6 - 16	2.5 - 16	6 - 16	2.5 - 16	6 - 16	2.5 - 16	309448	
	7 V	260	130	65	16 - 35	2.5 - 35	16 - 35	2.5 - 35	16 - 35	2.5 - 35	309449	



## Power Gel

### Two-component gel

to cast branch and connection boxes

The transparent two-component sealing compound provides a reliable protection to electrical and electronic components.

#### Characteristics

- Flexible two-component gel with mixing ratio of 1:1
- Transparent
- Vibration damping
- Removable
- Non-labelled and non-toxic
- Seals and protects all electrical installations
- Individual portioned
- Easy casting thanks to measuring cup

#### Application/Suitability

- Indoor areas (also with high humidity levels)
- Outdoor
- Branch and connection boxes
- Protection against moisture (Protection class: IP68)
- For electrical systems up to 1 kV



#### Scope of delivery

Power Gel component A and component B, measuring cup, spatula

Type		Art.-No.
Power Gel	400 ml	335120
	1000 ml	335121

Technical data	Value	Test standard
Viscosity (23 °C)	1000 mPa x s	ISO 3219
Pot life (23 °C)	15 min	
Dielectric strength	23 kV/mm	IEC 60243
Specific volume resistivity	$1 \times 10^{16} \Omega \times \text{cm}$	IEC 60093
Cone penetration	175 mm/10	ISO 2137







# MEDIUM VOLTAGE

Cable sets for unscreened polymeric cables . . . . .	123
Cable sets for screened polymeric cables . . . . .	129
Cable sets for mass-impregnated paper cables . . . . .	171
Heat shrinkable components . . . . .	191



# MEDIUM VOLTAGE

## Cable sets for unscreened polymeric cables

	Straight-through joints.....	124
	Cable terminations.....	127

MEDIUM VOLTAGE  
Cable sets for unscreened polymeric cables



## SMH3...MS6

### 3-core straight-through joint

for armoured 3-core polymeric cables without semi-conductive layer up to 7.2 kV

Straight-through joints SMH3...MS6 are suitable for armoured 3-core polymeric-insulated cables (PVC, PE, XLPE, EPR) without an outer semi-conductive layer. They allow the connection of cables with different cross sections and conductor materials even with different cable design. Suitable for compression or screw connectors.

#### Characteristics

- Compact dimensions
- Wide cross-section range
- Ready for immediate operation
- High mechanical strength
- Quick, safe and easy assembly

#### Application/Suitability

- Indoor
- Outdoor
- Underground
- Water
- Installation ducts
- Ductwork

#### Voltage level

- $U_0/U_m$  3.6/6 (7.2) kV - 3.8/6.6 (7.2) kV

#### Storage conditions/Shelf life

- Unlimited shelf life



Dimensions



#### Scope of delivery

Thick wall heat shrinkable outer tube with hot melt adhesive, inner sheath sleeve, copper braid tube, pressure spring, cleaning tissue, emery cloth, assembly instructions

Optional accessory: Connectors (see Connecting technology)

Type	L mm	max. Connector-Ø mm	max. Connector length mm	Polymeric cable armoured	
				Nominal cross section mm <sup>2</sup>	Art.-No.
$U_0/U_m$ 3.6/6 (7.2) kV - 3.8/6.6 (7.2) kV					
SMH3	25-70 MS6	850	20	110	25 - 70 145630
	50-150 MS6	1000	25	135	50 - 150 145633
	120-300 MS6	1200	40	150	120 - 300 145635



# SMHSV3-1...MS6 **NEW**

## Straight-through joint

with screw connectors, for connecting from 3-core with 1-core polymeric cables up to 7.2 kV

Straight-through joints SMHSV3-1...MS6 are suitable for connecting 3-core polymeric cables (PVC, PE, XLPE, EPR) without outer semi-conductive layer with three 1-core polymeric cables (PVC, PE, XLPE, EPR). They allow the connection of cables with different cross sections, conductive materials and structure. With screw connectors.

### Characteristics

- Compact dimensions
- Wide cross-section range
- Ready for immediate operation
- High mechanical strength
- Quick, safe and easy assembly
- Suitable for a wide range of applications due to integrated screw connector

### Application/Suitability

- Indoor
- Outdoor
- Underground
- Water
- Installation ducts
- Ductwork

### Voltage level

- $U_0/U_m$  3.6/6 (7.2) kV - 3.8/6.6 (7.2) kV

### Storage conditions/Shelf life

- Unlimited shelf life



### Dimensions



### Scope of delivery

Thick wall heat shrinkable outer tube with hot melt adhesive, inner sheath sleeve, copper braid tape, screw connectors, assembly material, assembly instructions

Type	L mm	Polymeric cable		Art.-No.
		unarmoured / armoured		
		Nominal cross section mm <sup>2</sup>		
$U_0/U_m$ 3.6/6 (7.2) kV - 3.8/6.6 (7.2) kV				
SMHSV3-1 50-150 MS6	750	50 - 150		311594

MEDIUM VOLTAGE  
Cable sets for unscreened polymeric cables



## M...MS6

### 3-core straight-through joint

for armoured 3-core polymeric cables without semi-conductive layer up to 7.2 kV

Straight-through joints M...MS6 are suitable for armoured 3-core polymeric-insulated cables (PVC, PE, XLPE, EPR) without an outer semi-conductive layer. They allow the connection of cables with different cross sections and conductor materials even with different cable design. They do not contain any substances which inhibit paint wetting and are suitable for use in the automotive industry. Suitable for compression connectors.

#### Characteristics

- Resistant to chemical agents
- Longitudinally and transversely watertight
- High mechanical strength
- Quick, safe and easy assembly

#### Application/Suitability

- Indoor
- Outdoor
- Underground
- Water
- Installation ducts
- Ductwork

#### Voltage level

- $U_0/U_m$  3.6/6 (7.2) kV - 3.8/6.6 (7.2) kV

#### Storage conditions/Shelf life

- Cast resin up to 40 months

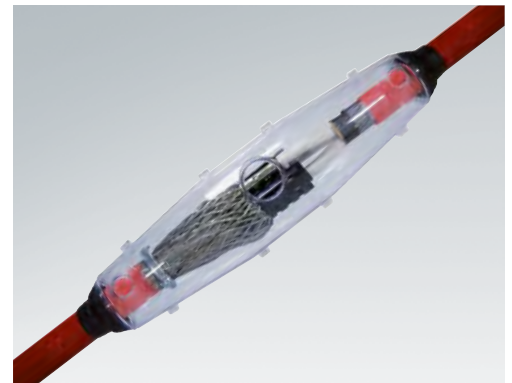

#### Dimensions

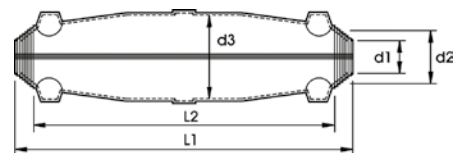

#### Scope of delivery

Spacer sleeve, hydrolysis resistance PUR type EG cast resin (containing the correct volume ready for mixing), packed in practical and easy-to-use two-chamber bags, transparent plastic shell, copper braid tube, hose clamp, fill and air-release funnels, PVC insulation tape, protective gloves, assembly instructions

Optional accessory: Connectors (see Connecting technology)

Type	L1 mm	L2 mm	D1 mm	D2 mm	D3 mm	Cable-Ø mm	Polymeric cable		Art.-No.	
							armoured	armoured with concentric conductor		
							Nominal cross section mm <sup>2</sup>			
$U_0/U_m$ 3.6/6 (7.2) kV - 3.8/6.6 (7.2) kV										
M4	MS6	432	384	29	52	90	29 - 55	25 - 70	25/25 - 50/50	124318
M5	MS6	550	503	40	62	110	42 - 65	95 - 120	70/70 - 95/95	124319
M6	MS6	660	600	50	78	145	50 - 78	150 - 240	120/120 - 185/185	124320



## SEEV

### 3-core indoor cable termination

for armoured 3-core polymeric cables without semi-conductive layer up to 7.2 kV

Cable terminations SEEV for indoor applications are suitable to cover armoured 3-core polymeric cables (PVC, PE, XLPE, EPR) without semi-conductive layer. Suitable for compression or screw cable lugs.

#### Characteristics

- Compact dimensions
- Wide conductor and cross-section range
- High mechanical strength
- Quick, safe and easy assembly

#### Application/Suitability

- Indoor

#### Voltage level

- $U_0/U_m$  3.6/6 (7.2) kV - 3.8/6.6 (7.2) kV

#### Storage conditions/Shelf life

- Unlimited shelf life



#### Scope of delivery

Core insulating tubes (tracking resistant), spreader cap, filling tape, earthing accessories, sealing tape, assembly instructions

Optional accessory: Cable lugs (see Connecting technology)

#### Dimensions

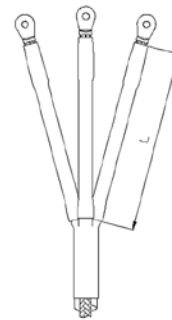

Type	L mm	Polymeric cable armoured		
		Nominal cross section mm <sup>2</sup>	Art.-No.	
$U_0/U_m$ 3.6/6 (7.2) kV - 3.8/6.6 (7.2) kV				
SEEV	16-50	280	16 - 50	145458
	70-120	280	70 - 120	145461
	150-240	280	150 - 240	145464
	300-400	280	300 - 400	171791



## SEEV-F 3-core outdoor cable termination

for armoured 3-core polymeric cables without semi-conductive layer up to 7.2 kV

Cable terminations SEEV-F for outdoor applications are suitable to cover armoured 3-core polymeric cables (PVC, PE, XLPE, EPR) without semi-conductive layer. Suitable for compression or screw cable lugs.

### Characteristics

- Compact dimensions
- Wide conductor and cross-section range
- High mechanical strength
- Quick, safe and easy assembly

### Application/Suitability

- Outdoor

### Voltage level

- $U_0/U_m$  3.6/6 (7.2) kV - 3.8/6.6 (7.2) kV

### Storage conditions/Shelf life

- Unlimited shelf life

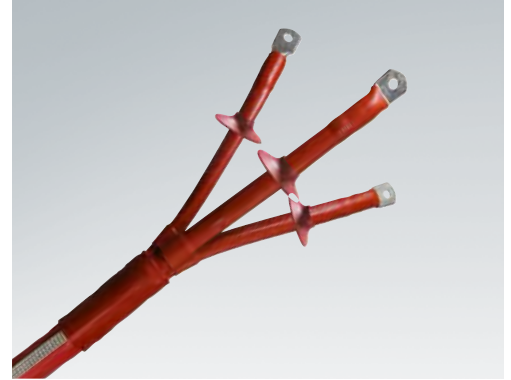

### Scope of delivery

Core insulating tubes (tracking resistant), spreader cap (tracking resistant), filling tape, silicone sheds, earthing accessories, sealing tape, assembly instructions

Optional accessory: Cable lugs (see Connecting technology)

### Dimensions

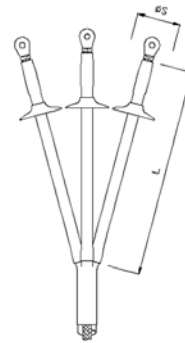

Ø S = Diameter of cable shed





Type	L mm	Ø S mm	Polymeric cable armoured		
			Nominal cross section mm <sup>2</sup>	Art.-No.	
$U_0/U_m$ 3.6/6 (7.2) kV - 3.8/6.6 (7.2) kV					
SEEV-F	16-50	400	80	16 - 50	148152
	70-120	400	85	70 - 120	182390
	150-240	400	85	150 - 240	148153

MEDIUM VOLTAGE  
Cable sets for unscreened polymeric cables



# MEDIUM VOLTAGE

## Cable sets for screened polymeric cables

	Straight-through joints for 1-core cables. ....	130
	Cable terminations for 1-core cables. ....	136
	Cable connectors for 1-core cables . ....	146
	Straight-through joints for 3-core cables. ....	161
	Cable terminations for 3-core cables. ....	165



## CHMSV

### 1-core straight-through joint

with screw connector, for all 1-core polymeric cables

Hybrid straight-through joints CHMSV are suitable for all 1-core polymeric-insulated cables (PVC, PE, XLPE, EPR). They allow the connection of cables with different cross sections and conductor materials even with different cable designs concerning the semi-conductive layer (graphite-coated, removable or strippable) and screen design (copper wire or tape screen). With screw connector.

#### Characteristics

- Reliable stress control due to flexible silicone stress control elements
- For both copper and aluminium conductors
- For all cables with copper wire or tape screen
- Wide conductor and cross-section range
- Quick, safe and easy assembly
- Ready for immediate operation
- Suitable for a wide range of applications due to integrated screw connector

#### Application/Suitability

- Indoor
- Outdoor
- Underground
- Water
- Installation ducts
- Ductwork

#### Voltage level

- $U_0/U_m$  6/10 (12) kV - 19/33 (36) kV

#### Note

- 12 kV joints must be used for 7.2 kV cables. (Check minimum diameter over conductor insulation.)

#### Test standards

- CENELEC HD 629.1 (DIN VDE 0278, part 629-1)

#### Storage conditions/Shelf life

- Unlimited shelf life



Dimensions



#### Scope of delivery

Thick wall heat shrinkable insulation tubes, thick wall heat shrinkable outer tube with hot melt adhesive, silicone stress control elements, copper braid tube, pressure springs, innovative screw connector with conductive cover, field control filling tape (blue), assembly material, assembly instructions

Note: Other straight-through joints available on request.

Type	L mm	min. Ø over core insulation after removal of the outer conductive layer mm	12 kV	17.5 kV	24 kV	36 kV	Art.-No.
			Nominal cross section mm <sup>2</sup>				
<b><math>U_0/U_m</math> 6/10 (12) kV - 6.35/11 (12) kV</b>							
<b>CHMSV 12kV</b>	25-95	600	12.6	25 - 95			258130
	70-150	600	14.7	70 - 150			258131
	95-240	600	17.3	95 - 240			258132
	240-400	650	23.1	240 - 400			258133
<b><math>U_0/U_m</math> 8.7/15 (17.5) kV</b>							
<b>CHMSV 17kV</b>	25-95	600	14.7	25 - 95			258135
	70-150	600	18.0	70 - 150			258136
	95-240	600	19.9	95 - 240			258137
	240-400	700	24.0	240 - 400			258138
<b><math>U_0/U_m</math> 12/20 (24) kV - 12.7/22 (24) kV</b>							
<b>CHMSV 24kV</b>	16-95	600	14.7		16 - 95		258140
	50-150	600	17.3		50 - 150		258141
	95-240	600	19.9		95 - 240		258142
	240-400	700	27.3		240 - 400		258143
<b><math>U_0/U_m</math> 18/30 (36) kV - 19/33 (36) kV</b>							
<b>CHMSV 36kV</b>	50-150	600	20.9			50 - 150	258144
	95-240	600	24.2			95 - 240	258145
	240-400	700	32.0			240 - 400	258146



## CHM...V

### 1-core straight-through joint

with screw connector, for all 1-core polymeric cables

Hybrid straight-through joints CHM...V are suitable for all 1-core polymeric-insulated cables (PVC, PE, XLPE, EPR). They allow the connection of cables with different cross sections and conductor materials even with different cable designs concerning the semi-conductive layer (graphite-coated, removable or strippable) and screen design (copper wire or tape screen). With screw connector.

#### Characteristics

- Reliable stress control due to flexible silicone stress control elements
- For both copper and aluminium conductors
- For all cables with copper wire or tape screen
- Wide conductor and cross-section range
- Quick, safe and easy assembly
- Ready for immediate operation
- Suitable for a wide range of applications due to screw connector

#### Application/Suitability

- Indoor
- Outdoor
- Underground
- Water
- Installation ducts
- Ductwork

#### Voltage level

- $U_0/U_m$  12/20 (24) kV - 12.7/22 (24) kV

#### Note

- 12 kV joints must be used for 7.2 kV cables. (Check minimum diameter over conductor insulation.)

#### Test standards

- CENELEC HD 629.1 (DIN VDE 0278, part 629-1)

#### Storage conditions/Shelf life

- Unlimited shelf life



Dimensions



#### Scope of delivery

Thick wall heat shrinkable insulation tubes, thick wall heat shrinkable outer tube with hot melt adhesive, silicone stress control elements, copper braid tube, pressure springs, screw connector, field control filling tape (blue), assembly material, assembly instructions

Type	L mm	min. Ø over core insulation after removal of the outer conductive layer mm	12 kV	17.5 kV	24 kV	Art.-No.	
			Nominal cross section mm <sup>2</sup>				
$U_0/U_m$ 12/20 (24) kV - 12.7/22 (24) kV							
CHM 24kV	400-630 V	850	32.7	630	500 - 630	400 - 630	262704
	630-1000 V	850	36.8	800 - 1000	630 - 1000	630 - 1000	308543
	800 V	1000	36.8	800	800	800	331184



## CHM

### 1-core straight-through joint

for all 1-core polymeric cables

Hybrid straight-through joints CHM are suitable for all 1-core polymeric-insulated cables (PVC, PE, XLPE, EPR). They allow the connection of cables with different cross sections and conductor materials even with different cable designs concerning the semi-conductive layer (graphite-coated, removable or strippable) and screen design (copper wire or tape screen). Suitable for compression connectors.

#### Characteristics

- Reliable stress control due to flexible silicone stress control elements
- For both copper and aluminium conductors
- For all cables with copper wire or tape screen
- Wide conductor and cross-section range
- Quick, safe and easy assembly
- Ready for immediate operation

#### Application/Suitability

- Indoor
- Outdoor
- Underground
- Water
- Installation ducts
- Ductwork

#### Voltage level

- $U_0/U_m$  6/10 (12) kV - 19/33 (36) kV

#### Note

- 12 kV joints must be used for 7.2 kV cables. (Check minimum diameter over conductor insulation.)

#### Test standards

- CENELEC HD 629.1 (DIN VDE 0278, part 629-1)

#### Storage conditions/Shelf life

- Unlimited shelf life



Dimensions



#### Scope of delivery

Thick wall heat shrinkable insulation tubes, thick wall heat shrinkable outer tube with hot melt adhesive, silicone stress control elements, copper braid tube, pressure springs, field control filling tape (blue), assembly material, assembly instructions

Optional accessory: Compression connectors (see Connecting technology)

Type	L mm	min. Ø over core insulation after removal of the outer conductive layer mm	max. Connector Ø mm	max. Connector length mm	12 kV	17.5 kV	24 kV	36 kV	Art.-No.	
					Nominal cross section mm <sup>2</sup>					
<b><math>U_0/U_m</math> 6/10 (12) kV - 6.35/11 (12) kV</b>										
CHM 12kV	10-25	650	9.9	16	90	10 - 25				194072
	35-95	650	12.6	25	135	35 - 95				194073
	95-240	650	17.3	32	145	95 - 240				194074
	150-300	700	19.9	40	200	150 - 300				194075
	300-400	700	23.1	40	200	300 - 400				194076
	500-800	850	27.3	60	360	500 - 800				194077
	800-1000	850	36.8	60	360	800 - 1000				194078
<b><math>U_0/U_m</math> 8.7/15 (17.5) kV</b>										
CHM 17kV	35-95	650	12.6	25	135		35 - 95			194079
	70-240	650	17.3	32	145		70 - 240			194080
	240-400	700	23.1	40	200		240 - 400			194082
	400-630	850	27.3	60	360		400 - 630			194083
	630-1000	850	36.8	60	360		630 - 1000			194085

→ Continued on the next page



→ Continuation

**CHM 1-core straight-through joint**

Type	L mm	min. Ø over core insulation after removal of the outer conductive layer mm	max. Connec- tor Ø mm	max. Connec- tor length mm	12 kV	17.5 kV	24 kV	36 kV	Art.-No.	
					Nominal cross section mm <sup>2</sup>					
<b>U<sub>0</sub>/U (U<sub>m</sub>) 12/20 (24) kV - 12.7/22 (24) kV</b>										
<b>CHM 24kV</b>	10-35	650	12.6	20	100			10 - 35		193339
	50-150	650	17.3	25	135			50 - 150		193370
	70-240	700	19.9	32	145			70 - 240		194086
	150-300	700	23.1	40	200			150 - 300		194087
	400-630	850	27.3	60	360			400 - 630		194088
	630-1000	850	36.8	60	360			630 - 1000		194089
<b>U<sub>0</sub>/U (U<sub>m</sub>) 18/30 (36) kV - 19/33 (36) kV</b>										
<b>CHM 36kV</b>	35-70	650	19.9	20	110				35 - 70	194090
	50-150	700	23.1	25	135				50 - 150	194091
	150-300	700	27.3	38	200				150 - 300	194092
	300-500	700	27.3	45	200				300 - 500	194093
	500-800	850	36.8	60	360				500 - 800	194094



## CAM-S

### 1-core straight-through joint

for all 1-core polymeric cables

Straight-through joints CAM-S are suitable for all 1-core polymeric-insulated cables (PVC, PE, XLPE, EPR). They allow the connection of cables with different cross sections and conductor materials even with different cable designs concerning the semi-conductive layer (graphite-coated, removable or strippable) and screen design (wire or tape screen). Suitable for compression connectors.

#### Characteristics

- Reliable stress control due to flexible silicone stress control elements
- Wide conductor and cross-section range
- Silicone slip-on components for quick, safe and easy assembly
- Ready for immediate operation

#### Application/Suitability

- Indoor
- Outdoor
- Underground
- Water
- Installation ducts
- Ductwork

#### Voltage level

- $U_0/U_m$  6/10 (12) kV - 12.7/22 (24) kV

#### Note

- 12 kV joints must be used for 7.2 kV cables. (Check minimum diameter over conductor insulation.)

#### Test standards

- CENELEC HD 629.1 (DIN VDE 0278, part 629-1)

#### Storage conditions/Shelf life

- Unlimited shelf life



Dimensions



#### Scope of delivery

Thick wall heat shrinkable outer tube with hot melt adhesive, silicone stress control elements, silicone joint unit with integrated semi-conductive layer (individually tested), copper braid tube, pressure springs, semiconductor tape, assembly instructions

Optional accessory: Compression connectors (see Connecting technology)

Type	L mm	min. Ø over core insulation after removal of the outer conductive layer mm	max. Connector length mm	12 kV	24 kV	Art.-No.
				Nominal cross section mm <sup>2</sup>		
<b><math>U_0/U_m</math> 6/10 (12) kV - 6.35/11 (12) kV</b>						
CAM-S 12kV	25-95	700	12.6	160	25 - 95	201385
	50-240	700	14.7	160	50 - 240	201386
	150-400	700	19.9	160	150 - 400	201388
<b><math>U_0/U_m</math> 12/20 (24) kV - 12.7/22 (24) kV</b>						
CAM-S 24kV	16-120	700	14.7	160	16 - 120	201393
	70-240	700	19.9	160	70 - 240	201395



## CKM

### 1-core straight-through joint

with screw connector, for all 1-core polymeric cables

Compax straight-through joints CKM are suitable for all 1-core polymeric-insulated cables (PVC, PE, XLPE, EPR) with different types of semi-conductive layers (graphite-coated, removable or strippable) and screen design (wire or tape screen), up to maximum network voltage of 24 kV. With integrated screw connector.

#### Characteristics

- Compact design
- With integrated screw connector
- Resistant to alkaline earth elements
- Moisture-resistant
- Corrosion-resistant
- Superior mechanical properties
- Quick, safe and easy assembly
- Ready for immediate operation

#### Application/Suitability

- Indoor
- Underground
- Installation ducts

#### Voltage level

- $U_0/U_m$  6/10 (12) kV - 12.7/22 (24) kV

#### Test standards

- CENELEC HD 629.1 (DIN VDE 0278, part 629-1)

#### Storage conditions/Shelf life

- Unlimited shelf life



#### Dimensions

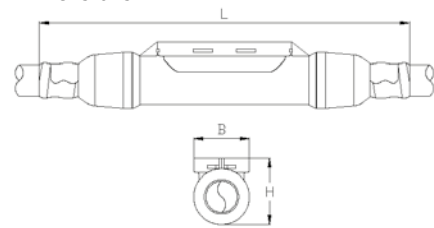

#### Scope of delivery

Double plug, joint unit with integrated outer housing, inner semi-conductive layer, silicone field control element and screw connector, pressure springs, padding tape, housing cover with integrated seal, nozzle with slide-on applicator, assembly material, assembly instructions

MEDIUM VOLTAGE  
Cable sets for screened polymeric cables

Type	L mm	B mm	H mm	Ø over core insulation after removal of the outer conductive layer mm	12 kV	17.5 kV	24 kV	Art.-No.	
					Nominal cross section mm <sup>2</sup>				
$U_0/U_m$ 6/10 (12) kV - 12.7/22 (24) kV									
CKM 24kV	50-150	470	71	85	15.1 - 28.5	70 - 150	70 - 150	50 - 150	252101
	95-240	470	71	85	19.9 - 32.6	120 - 240	120 - 240	95 - 240	251713
	240-400	585	80	110	27.4 - 40.8	300 - 400	240 - 400	240 - 400	306220
	630	585	80	110	28.6 - 40.8	Al/RE*: 630	Al/RE*: 630	Al/RE*: 630	312445

\* Al = Aluminium, RE = Round, massive



## CHESK-I 1-core indoor cable termination

with screw cable lugs, for all 1-core polymeric cables

Hybrid cable terminations CHESK-I are suitable for all 1-core polymeric-insulated cables (PVC, PE, XLPE, EPR) with different types of semi-conductive layers (graphite-coated, removable or strippable) and screen design (copper wire or tape). With screw cable lugs for main conductor and copper wire screen.

### Characteristics

- Flexible silicone stress control elements ensure reliable stress control under all operating conditions
- Combination of slip-on and heat shrinkable components
- Wide cross-section range
- Quick, safe and easy assembly
- Ready for immediate operation

### Application/Suitability

- Indoor
- Voltage level**
- $U_0/U (U_m)$  6/10 (12) kV - 19/33 (36) kV

### Note

- 12 kV cable terminations must be used for 7.2 kV cables. (Check minimum diameter over conductor insulation.)

### Test standards

- CENELEC HD 629.1 (DIN VDE 0278, part 629-1)

### Storage conditions/Shelf life

- Unlimited shelf life



### Dimensions

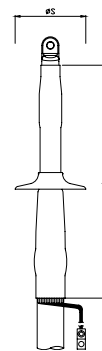

Ø S = Diameter of cable shed

### Scope of delivery

1 set for 3 phases, heat shrinkable tube (tracking resistant), silicone stress control elements, silicone sheds, sealing tape, screw cable lugs, assembly material, assembly instructions

Optional accessory: EGA earthing kit for cables with tape screen (see Connecting technology)

Type	L mm	min. Ø over core insulation after removal of the outer conductive layer mm	Number of sheds per phase	Ø S mm	12 kV	17.5 kV	24 kV	36 kV	Art.-No.
					Nominal cross section mm <sup>2</sup>				
<b><math>U_0/U (U_m)</math> 6/10 (12) kV - 6.35/11 (12) kV</b>									
CHESK-I 12kV	25-95	300	12.6		25 - 95				290443
	70-150	300	17.3		70 - 150				309514
	95-240	300	17.3		95 - 240				290444
	240-400	300	19.9		240 - 400				309516
<b><math>U_0/U (U_m)</math> 8.7/15 (17.5) kV</b>									
CHESK-I 17kV	35-95	300	17.3	1	85	35 - 95			309517
	50-150	300	17.3	1	85	50 - 150			309519
	95-240	300	19.9	1	85	95 - 240			309520
	240-400	300	23.1	1	85	240 - 400			309521
<b><math>U_0/U (U_m)</math> 12/20 (24) kV - 12.7/22 (24) kV</b>									
CHESK-I 24kV	25-95	300	17.3	1	85		25 - 95		309522
	50-150	300	17.3	1	85		50 - 150		309523
	95-240	300	19.9	1	85		95 - 240		309525
	240-400	300	27.3	1	115		240 - 400		309526
<b><math>U_0/U (U_m)</math> 18/30 (36) kV - 19/33 (36) kV</b>									
CHESK-I 36kV	16-95	500	19.9	2	85			16 - 95	309527
	50-150	500	23.1	2	85			50 - 150	309528
	95-240	500	23.1	2	85			95 - 240	309529
	240-400	500	27.3	2	115			240 - 400	309530





## CHE-I

### 1-core indoor cable termination

for all 1-core polymeric cables

Hybrid cable terminations CHE-I are suitable for all 1-core polymeric-insulated cables (PVC, PE, XLPE, EPR) with different types of semi-conductive layers (graphite-coated, removable or strippable) and screen design (copper wire or tape). Suitable for compression or screw cable lugs.

#### Characteristics

- Flexible silicone stress control elements ensure reliable stress control under all operating conditions
- Combination of slip-on and heat shrinkable components
- Wide cross-section range
- Quick, safe and easy assembly
- Ready for immediate operation

#### Application/Suitability

- Indoor
- Voltage level**
- $U_0/U_m$  6/10 (12) kV - 19/33 (36) kV

#### Note

- 12 kV cable terminations must be used for 7.2 kV cables. (Check minimum diameter over conductor insulation.)

#### Test standards

- CENELEC HD 629.1 (DIN VDE 0278, part 629-1)

#### Storage conditions/Shelf life

- Unlimited shelf life



#### Dimensions



Ø S = Diameter of cable shed

#### Scope of delivery

1 set for 3 phases, heat shrinkable tube (tracking resistant), silicone stress control elements, silicone sheds, sealing tape, assembly material, assembly instructions

Optional accessory: Cable lugs (see Connecting technology)  
EGA earthing kit for cables with tape screen (see Connecting technology)

Type	L mm	min. Ø over core insulation after removal of the outer conductive layer mm	Number of sheds per phase	Ø S mm	12 kV	17.5 kV	24 kV	36 kV	Art.-No.
					Nominal cross section mm <sup>2</sup>				
<b><math>U_0/U_m</math> 6/10 (12) kV - 6.35/11 (12) kV</b>									
CHE-I 12kV	10-25	300	9.9		10 - 25				193414
	25-95	300	12.6		25 - 95				193416
	95-240	300	17.3		95 - 240				194017
	150-400	300	19.9		150 - 400				194018
	240-500	300	23.1		240 - 500				194019
	400-800	300	27.3		400 - 800				194030
	800-1000	300	36.8		800 - 1000				194031
<b><math>U_0/U_m</math> 8.7/15 (17.5) kV</b>									
CHE-I 17kV	10-16	300	9.9	1	80	10 - 16			194032
	16-50	300	12.6	1	80	16 - 50			194033
	70-240	300	17.3	1	85	70 - 240			194034
	120-300	300	19.9	1	85	120 - 300			194035
	185-400	300	23.1	1	85	185 - 400			194036
	300-630	300	27.3	1	115	300 - 630			194037
	630-1000	300	36.8	1	123	630 - 1000			194038

→ Continued on the next page



→ Continuation

## CHE-I 1-core indoor cable termination

Type	L mm	min. Ø over core insulation after removal of the outer conductive layer mm	Number of sheds per phase	Ø S mm	12 kV	17.5 kV	24 kV	36 kV	Art.-No.
					Nominal cross section mm <sup>2</sup>				
<b>U<sub>0</sub>/U (U<sub>m</sub>) 12/20 (24) kV - 12.7/22 (24) kV</b>									
<b>CHE-I 24kV</b>	10-35	300	12.6	1	85			10 - 35	194039
	25-150	300	17.3	1	85			25 - 150	194040
	70-240	300	19.9	1	85			70 - 240	194041
	120-300	300	23.1	1	85			120 - 300	194042
	240-500	300	27.3	1	115			240 - 500	194043
	630-1000	300	36.8	1	123			630 - 1000	194044
<b>U<sub>0</sub>/U (U<sub>m</sub>) 18/30 (36) kV - 19/33 (36) kV</b>									
<b>CHE-I 36kV</b>	35-70	500	19.9	2	85			35 - 70	194045
	50-150	500	23.1	2	85			50 - 150	194046
	150-400	500	27.3	2	115			150 - 400	194047
	500-800	500	36.8	2	123			500 - 800	194048

MEDIUM VOLTAGE  
Cable sets for screened polymeric cables



## CHESK-F

### 1-core outdoor cable termination

with screw cable lugs, for all 1-core polymeric cables

Hybrid cable terminations CHESK-F are suitable for all 1-core polymeric-insulated cables (PVC, PE, XLPE, EPR) with different types of semi-conductive layers (graphite-coated, removable or strippable) and screen design (copper wire or tape). With screw cable lugs for main conductor and copper wire screen.

#### Characteristics

- Flexible silicone stress control elements ensure reliable stress control under all operating conditions
- Combination of slip-on and heat shrinkable components
- Wide cross-section range
- Quick, safe and easy assembly
- Ready for immediate operation

#### Application/Suitability

- Outdoor

#### Voltage level

- $U_0/U (U_m)$  6/10 (12) kV - 19/33 (36) kV

#### Note

- 12 kV cable terminations must be used for 7.2 kV cables. (Check minimum diameter over conductor insulation.)

#### Test standards

- CENELEC HD 629.1 (DIN VDE 0278, part 629-1)

#### Storage conditions/Shelf life

- Unlimited shelf life



#### Dimensions

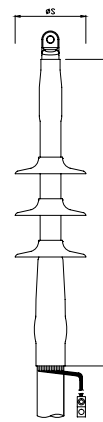

Ø S = Diameter of cable shed

#### Scope of delivery

1 set for 3 phases, heat shrinkable tube (tracking resistant), silicone stress control elements, silicone sheds, sealing tape, screw cable lugs, assembly material, assembly instructions

Optional accessory: EGA earthing kit for cables with tape screen (see Connecting technology)

MEDIUM VOLTAGE  
Cable sets for screened polymeric cables

Type	L mm	min. Ø over core insulation after removal of the outer conductive layer mm	Number of sheds per phase	Ø S mm	12 kV	17.5 kV	24 kV	36 kV	Art.-No.
					Nominal cross section mm <sup>2</sup>				
<b><math>U_0/U (U_m)</math> 6/10 (12) kV - 6.35/11 (12) kV</b>									
CHESK-F 12kV	25-95	300	12.6	1	80	25 - 95			309534
	70-150	300	17.3	1	85	70 - 150			309535
	95-240	300	17.3	1	85	95 - 240			309536
	240-400	300	19.9	1	85	240 - 400			309537
<b><math>U_0/U (U_m)</math> 8.7/15 (17.5) kV</b>									
CHESK-F 17kV	35-95	500	17.3	2	85		35 - 95		309539
	50-150	500	17.3	2	85		50 - 150		309540
	95-240	500	19.9	2	85		95 - 240		309541
	240-400	500	23.1	2	85		240 - 400		309542
<b><math>U_0/U (U_m)</math> 12/20 (24) kV - 12.7/22 (24) kV</b>									
CHESK-F 24kV	25-95	500	17.3	3	85			25 - 95	309545
	50-150	500	17.3	3	85			50 - 150	309546
	95-240	500	19.9	3	85			95 - 240	309548
	240-400	500	27.3	3	115			240 - 400	309550
<b><math>U_0/U (U_m)</math> 18/30 (36) kV - 19/33 (36) kV</b>									
CHESK-F 36kV	16-95	700	19.9	4	85			16 - 95	309551
	50-150	700	23.1	4	85			50 - 150	309552
	95-240	700	23.1	4	85			95 - 240	309553
	240-400	700	27.3	4	115			240 - 400	309554



## CHE-F

### 1-core outdoor cable termination

for all 1-core polymeric cables

Hybrid cable terminations CHE-F are suitable for all 1-core polymeric-insulated cables (PVC, PE, XLPE, EPR) with different types of semi-conductive layers (graphite-coated, removable or strippable) and screen design (copper wire or tape). Suitable for compression or screw cable lugs.

#### Characteristics

- Flexible silicone stress control elements ensure reliable stress control under all operating conditions
- Combination of slip-on and heat shrinkable components
- Wide cross-section range
- Quick, safe and easy assembly
- Ready for immediate operation

#### Application/Suitability

- Outdoor

#### Voltage level

- $U_0/U_m$  6/10 (12) kV - 19/33 (36) kV

#### Note

- 12 kV cable terminations must be used for 7.2 kV cables. (Check minimum diameter over conductor insulation.)

#### Test standards

- CENELEC HD 629.1 (DIN VDE 0278, part 629-1)

#### Storage conditions/Shelf life

- Unlimited shelf life



#### Dimensions

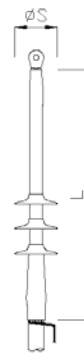

Ø S = Diameter of cable shed

#### Scope of delivery

1 set for 3 phases, heat shrinkable tube (tracking resistant), silicone stress control elements, silicone sheds, sealing tape, assembly material, assembly instructions

Optional accessory: Cable lugs (see Connecting technology)  
EGA earthing kit for cables with tape screen (see Connecting technology)

Type	L mm	min. Ø over core insulation after removal of the outer conductive layer mm	Number of sheds per phase	Ø S mm	12 kV	17.5 kV	24 kV	36 kV	Art.-No.	
					Nominal cross section mm <sup>2</sup>					
<b><math>U_0/U_m</math> 6/10 (12) kV - 6.35/11 (12) kV</b>										
CHE-F 12kV	10-25	300	9.9	1	80	10 - 25				194049
	25-95	300	12.6	1	80	25 - 95				194050
	95-240	300	17.3	1	85	95 - 240				194051
	150-400	300	19.9	1	85	150 - 400				194052
	240-500	300	23.1	1	85	240 - 500				194053
	400-800	300	27.3	1	115	400 - 800				194054
	800-1000	300	36.8	1	123	800 - 1000				194055
<b><math>U_0/U_m</math> 8.7/15 (17.5) kV</b>										
CHE-F 17kV	10-16	500	9.9	2	80		10 - 16			194056
	16-50	500	12.6	2	80		16 - 50			194057
	70-240	500	17.3	2	85		70 - 240			194058
	120-300	500	19.9	2	85		120 - 300			194059
	185-400	500	23.1	2	85		185 - 400			194061
	300-630	500	27.3	2	115		300 - 630			194062
	630-1000	500	36.8	2	123		630 - 1000			194063

→ Continued on the next page



→ Continuation

**CHE-F 1-core outdoor cable termination**

Type	L mm	min. Ø over core insulation after removal of the outer conductive layer mm	Number of sheds per phase	Ø S mm	12 kV	17.5 kV	24 kV	36 kV	Art.-No.
					Nominal cross section mm <sup>2</sup>				
<b>U<sub>0</sub>/U (U<sub>m</sub>) 12/20 (24) kV - 12.7/22 (24) kV</b>									
<b>CHE-F 24kV</b>	10-35	500	12.6	3	85			10 - 35	193372
	25-150	500	17.3	3	85			25 - 150	193374
	70-240	500	19.9	3	85			70 - 240	194064
	120-300	500	23.1	3	85			120 - 300	194065
	240-500	500	27.3	3	115			240 - 500	194066
	630-1000	500	36.8	3	123			630 - 1000	194067
<b>U<sub>0</sub>/U (U<sub>m</sub>) 18/30 (36) kV - 19/33 (36) kV</b>									
<b>CHE-F 36kV</b>	35-70	700	19.9	4	85			35 - 70	194068
	50-150	700	23.1	4	85			50 - 150	194069
	150-400	700	27.3	4	115			150 - 400	194070
	500-800	700	36.8	4	123			500 - 800	194071

**MEDIUM VOLTAGE**  
 Cable sets for screened polymeric cables



# CAESK-I 1-core indoor cable termination

with screw cable lugs, for all 1-core polymeric cables

Contrax cable terminations CAESK-I are suitable for all 1-core polymeric-insulated cables (PVC, PE, XLPE, EPR) with different types of semi-conductive layers (graphite-coated, removable or strippable) and screen design (wire or tape). With screw cable lugs.

### Characteristics

- Wide cross-section range
- Silicone slip-on components for quick, safe and easy assembly
- Ready for immediate operation

### Application/Suitability

- Indoor
- Voltage level**
- $U_0/U_m$  6/10 (12) kV - 19/33 (36) kV

### Note

- 12 kV cable terminations must be used for 7.2 kV cables. (Check minimum diameter over conductor insulation.)

### Test standards

- CENELEC HD 629.1 (DIN VDE 0278, part 629-1)

### Storage conditions/Shelf life

- Unlimited shelf life



### Dimensions



Ø S = Diameter of cable shed

### Scope of delivery

3 one-piece slip-on silicone cable terminations with integrated stress control element, silicone tubes, sealing tape, screw cable lugs for main conductor, assembly material, assembly instructions

Optional accessory: EGA earthing kit for cables with tape screen (see Connecting technology)

Type	L mm	min. Ø over core insulation after removal of the outer conductive layer mm	Number of sheds per phase	Ø S mm	12 kV	17.5 kV	24 kV	36 kV	Art.-No.	
					Nominal cross section mm <sup>2</sup>					
<b><math>U_0/U_m</math> 6/10 (12) kV - 6.35/11 (12) kV</b>										
CAESK-I 12kV	95-150	310	17.3	1	87	95 - 150				289945
	150-240	330	19.9	1	90	150 - 240				289947
	300-400	340	26.6	1	93	300 - 400				289948
	500-630	360	32.3	1	97	500 - 630				289949
<b><math>U_0/U_m</math> 8.7/15 (17.5) kV</b>										
CAESK-I 17kV	50-95	310	17.3	1	87		50 - 95			289950
	95-150	310	19.9	1	90		95 - 150			289951
	150-240	330	23.1	1	93		150 - 240			289952
	240-400	340	27.3	1	97		240 - 400			289953
	400-500	360	32.3	1	97		400 - 500			289954
<b><math>U_0/U_m</math> 12/20 (24) kV - 12.7/22 (24) kV</b>										
CAESK-I 24kV	35-95	310	17.3	1	87			35 - 95		289955
	70-150	310	19.9	1	90			70 - 150		289956
	120-240	330	23.1	1	90			120 - 240		289957
	240-400	340	27.3	1	97			240 - 400		289958
	400-500	360	32.3	1	97			400 - 500		289959
<b><math>U_0/U_m</math> 18/30 (36) kV - 19/33 (36) kV</b>										
CAESK-I 36kV	16-95	360	20.9	4	93				16 - 95	289960
	70-150	360	24.2	4	93				70 - 150	289961
	120-240	380	28.6	4	97				120 - 240	289962
	240-300	390	32.3	4	97				240 - 300	289963



## CAE-I

### 1-core indoor cable termination

for all 1-core polymeric cables

Contrax cable terminations CAE-I are suitable for all 1-core polymeric-insulated cables (PVC, PE, XLPE, EPR) with different types of semi-conductive layers (graphite-coated, removable or strippable) and screen design (wire or tape). Suitable for compression cable lugs.

#### Characteristics

- Wide cross-section range
- Silicone slip-on components for quick, safe and easy assembly
- Ready for immediate operation

#### Application/Suitability

- Indoor

#### Voltage level

- $U_0/U_m$  6/10 (12) kV - 19/33 (36) kV

#### Note

- 12 kV cable terminations must be used for 7.2 kV cables. (Check minimum diameter over conductor insulation.)

#### Test standards

- CENELEC HD 629.1 (DIN VDE 0278, part 629-1)

#### Storage conditions/Shelf life

- Unlimited shelf life



#### Dimensions



Ø S = Diameter of cable shed

#### Scope of delivery

3 one-piece slip-on silicone cable terminations with integrated stress control element, sealing tape, assembly material, assembly instructions

Optional accessory: Compression cable lugs (see Connecting technology)  
EGA earthing kit for cables with tape screen (see Connecting technology)

Type	L mm	min. Ø over core insulation after removal of the outer conductive layer mm	Number of sheds per phase	Ø S mm	12 kV	17.5 kV	24 kV	36 kV	Art.-No.	
					Nominal cross section mm <sup>2</sup>					
<b><math>U_0/U_m</math> 6/10 (12) kV - 6.35/11 (12) kV</b>										
CAE-I 12kV	95-240	270	17.3	1	87	95 - 240				199151
	150-400	270	19.9	1	90	150 - 400				199152
	240-500	270	23.1	1	93	240 - 500				199154
	300-800	270	27.3	1	97	300 - 800				199155
<b><math>U_0/U_m</math> 8.7/15 (17.5) kV</b>										
CAE-I 17kV	50-185	270	17.3	1	87		50 - 185			199157
	95-240	270	19.9	1	90		95 - 240			199158
	150-400	270	23.1	1	93		150 - 400			199159
	240-630	270	27.3	1	97		240 - 630			199160
<b><math>U_0/U_m</math> 12/20 (24) kV - 12.7/22 (24) kV</b>										
CAE-I 24kV	35-120	270	17.3	1	87			35 - 120		199162
	70-240	270	19.9	1	90			70 - 240		199163
	120-400	270	23.1	1	93			120 - 400		199164
	240-630	270	27.3	1	97			240 - 630		199165
<b><math>U_0/U_m</math> 18/30 (36) kV - 19/33 (36) kV</b>										
CAE-I 36kV	16-95	325	19.9	4	90				16 - 95	199166
	50-240	325	23.1	4	93				50 - 240	199167
	120-400	325	27.3	4	97				120 - 400	199168



## CAESK-F

### 1-core outdoor cable termination

with screw cable lugs, for all 1-core polymeric cables

Contrax cable terminations CAESK-F are suitable for all 1-core polymeric-insulated cables (PVC, PE, XLPE, EPR) with different types of semi-conductive layers (graphite-coated, removable or strippable) and screen design (wire or tape). With screw cable lugs.

#### Characteristics

- Wide cross-section range
- Silicone slip-on components for quick, safe and easy assembly
- Ready for immediate operation

#### Application/Suitability

- Outdoor

#### Voltage level

- $U_0/U (U_m)$  6/10 (12) kV - 19/33 (36) kV

#### Note

- 12 kV cable terminations must be used for 7.2 kV cables. (Check minimum diameter over conductor insulation.)

#### Test standards

- CENELEC HD 629.1 (DIN VDE 0278, part 629-1)

#### Storage conditions/Shelf life

- Unlimited shelf life



#### Dimensions



Ø S = Diameter of cable shed

#### Scope of delivery

3 one-piece slip-on silicone cable terminations with integrated stress control element, silicone tubes, sealing tape, screw cable lugs for main conductor, assembly material, assembly instructions

Optional accessory: EGA earthing kit for cables with tape screen (see Connecting technology)

Type	L mm	min. Ø over core insulation after removal of the outer conductive layer mm	Number of sheds per phase	Ø S mm	12 kV	17.5 kV	24 kV	36 kV	Art.-No.	
					Nominal cross section mm <sup>2</sup>					
<b><math>U_0/U (U_m)</math> 6/10 (12) kV - 6.35/11 (12) kV</b>										
CAESK-F 12kV	95-150	360	17.3	4	87	95 - 150			289894	
	150-240	390	19.9	4	90	150 - 240			289897	
	300-400	390	26.6	4	93	300 - 400			289898	
	500-630	410	32.3	4	97	500 - 630			289899	
<b><math>U_0/U (U_m)</math> 8.7/15 (17.5) kV</b>										
CAESK-F 17kV	50-95	360	17.3	4	87		50 - 95		289900	
	95-150	360	19.9	4	90		95 - 150		289901	
	150-240	390	23.1	4	97		150 - 240		289902	
	240-400	410	27.3	4	97		240 - 400		289903	
	400-500	410	32.3	4	97		400 - 500		289904	
<b><math>U_0/U (U_m)</math> 12/20 (24) kV - 12.7/22 (24) kV</b>										
CAESK-F 24kV	35-95	360	17.3	4	87			35 - 95	289905	
	70-150	360	19.9	4	90			70 - 150	289906	
	120-240	390	23.1	4	93			120 - 240	289907	
	240-400	410	27.3	4	97			240 - 400	289908	
	400-500	410	32.3	4	97			400 - 500	289909	
<b><math>U_0/U (U_m)</math> 18/30 (36) kV - 19/33 (36) kV</b>										
CAESK-F 36kV	70-150	470	24.2	5	93				70 - 150	289910
	120-240	500	28.6	5	97				120 - 240	289911
	240-300	500	32.3	5	97				240 - 300	289912





## CAE-F

### 1-core outdoor cable termination

for all 1-core polymeric cables

Conrax cable terminations CAE-F are suitable for all 1-core polymeric-insulated cables (PVC, PE, XLPE, EPR) with different types of semi-conductive layers (graphite-coated, removable or strippable) and screen design (wire or tape). Suitable for compression cable lugs.

#### Characteristics

- Wide cross-section range
- Silicone slip-on components for quick, safe and easy assembly
- Ready for immediate operation

#### Application/Suitability

- Outdoor

#### Voltage level

- $U_0/U_m$  6/10 (12) kV - 19/33 (36) kV

#### Note

- 12 kV cable terminations must be used for 7.2 kV cables. (Check minimum diameter over conductor insulation.)

#### Test standards

- CENELEC HD 629.1 (DIN VDE 0278, part 629-1)

#### Storage conditions/Shelf life

- Unlimited shelf life



#### Dimensions



Ø S = Diameter of cable shed

#### Scope of delivery

3 one-piece slip-on silicone cable terminations with integrated stress control element, sealing tape, assembly material, assembly instructions

Optional accessory: Compression cable lugs (see Connecting technology)  
EGA earthing kit for cables with tape screen (see Connecting technology)

Type	L mm	min. Ø over core insulation after removal of the outer conductive layer mm	Number of sheds per phase	Ø S mm	12 kV	17.5 kV	24 kV	36 kV	Art.-No.
					Nominal cross section mm <sup>2</sup>				
<b><math>U_0/U_m</math> 6/10 (12) kV - 6.35/11 (12) kV</b>									
CAE-F 12kV	95-240	325	17.3	4	87	95 - 240			199184
	150-400	325	19.9	4	90	150 - 400			199185
	240-500	325	23.1	4	93	240 - 500			199186
	300-800	325	27.3	4	97	300 - 800			199187
<b><math>U_0/U_m</math> 8.7/15 (17.5) kV</b>									
CAE-F 17kV	50-185	325	17.3	4	87		50 - 185		199189
	95-240	325	19.9	4	90		95 - 240		199190
	150-400	325	23.1	4	93		150 - 400		199191
	240-630	325	27.3	4	97		240 - 630		199192
<b><math>U_0/U_m</math> 12/20 (24) kV - 12.7/22 (24) kV</b>									
CAE-F 24kV	35-120	325	17.3	4	87			35 - 120	199194
	70-240	325	19.9	4	90			70 - 240	199195
	120-400	325	23.1	4	93			120 - 400	199196
	240-630	325	27.3	4	97			240 - 630	199197
<b><math>U_0/U_m</math> 18/30 (36) kV - 19/33 (36) kV</b>									
CAE-F 36kV	50-240	440	23.1	5	93			50 - 240	199198
	120-400	440	27.3	5	97			120 - 400	199199



## CWS 250A Elbow separable cable connector

for all 1-core polymeric cables, for outer cone system terminals type A

Cellplux elbow separable cable connectors CWS are suitable for connecting all polymeric-insulated 1-core cables (PVC, PE, XLPE, EPR), with different types of semi-conductive layers (graphite-coated or strippable) and screen design (wire or tape screen), to switching equipment and transformers having an outer cone system type A, up to maximum network voltage of 24 kV in accordance with EN 50180 and EN 50181.

### Characteristics

- With capacitive measuring point
- Individually tested
- Outer semi-conductive layer made of semi-conductive EPDM provides protection from exposed electrical parts
- Cable sheath insulation fault test may be performed while under voltage
- For copper and aluminium conductors
- Quick, safe and easy assembly
- Suitable for a wide range of applications due to integrated screw cable lug

### Application/Suitability

- Indoor
- Voltage level**
- $U_o/U_m$  6/10 (12) kV - 12.7/22 (24) kV

### Test standards

- CENELEC HD 629.1 (DIN VDE 0278, part 629-1)

### Storage conditions/Shelf life

- Unlimited shelf life



### Dimensions

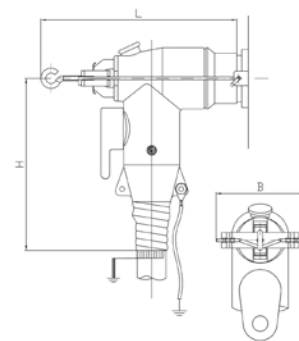

### Scope of delivery

Set of 3 separable cable connectors, silicone stress control elements, earthing set, screw cable lug for main conductor, assembly material, assembly instructions

Optional accessory: EGA earthing kit for cables with tape screen (see Connecting technology)

Type	L mm	B mm	H mm	min. Ø over core insulation after removal of the outer conductive layer mm	12 kV	17.5 kV	24 kV	Art.-No.	
					Nominal cross section mm <sup>2</sup>				
$U_o/U_m$ 6/10 (12) kV - 12.7/22 (24) kV									
CWS 250A 24kV	16-95 M EGA	200	80	178	14.7	50 - 95	25 - 95	16 - 95	295167
	70-150 M EGA	200	80	178	19.9	120 - 150	95 - 150	70 - 150	293792



## CGS 250A

### Straight separable cable connector

for all 1-core polymeric cables, for outer cone system terminals type A

Cellplex straight separable cable connectors CGS are suitable for connecting all polymeric-insulated 1-core cables (PVC, PE, XLPE, EPR), with different types of semi-conductive layers (graphite-coated or strippable) and screen design (wire or tape screen) for switching equipment and transformers having an outer cone system type A, up to maximum network voltage of 24 kV in accordance with EN 50180 and EN 50181.

#### Characteristics

- With capacitive measuring point
- Individually tested
- Outer semi-conductive layer made of semi-conductive EPDM provides protection from exposed electrical parts
- Cable sheath insulation fault test may be performed while under voltage
- For copper and aluminium conductors
- Quick, safe and easy assembly
- Suitable for a wide range of applications due to integrated screw cable lug

#### Application/Suitability

- Indoor

#### Voltage level

- $U_0/U_m$  (U<sub>m</sub>) 6/10 (12) kV - 12.7/22 (24) kV

#### Test standards

- CENELEC HD 629.1 (DIN VDE 0278, part 629-1)

#### Storage conditions/Shelf life

- Unlimited shelf life



#### Dimensions

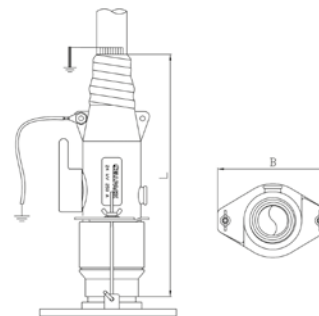

#### Scope of delivery

Set of 3 separable cable connectors, silicone stress control elements, earthing set, screw cable lug for main conductor, assembly material, assembly instructions

Optional accessory: EGA earthing kit for cables with tape screen (see Connecting technology)

Type	L mm	B mm	min. Ø over core insulation after removal of the outer conductive layer mm	12 kV	17.5 kV	24 kV	Art.-No.	
				Nominal cross section mm <sup>2</sup>				
$U_0/U_m$ (U <sub>m</sub> ) 6/10 (12) kV - 12.7/22 (24) kV								
CGS 250A 24kV	25-95 M EGA	248	110	14.7	50 - 95	25 - 95	25 - 95	295283
	70-150 M EGA	248	110	19.9	120 - 150	95 - 150	70 - 150	293797



## CWS 400A Elbow separable cable connector

for all 1-core polymeric cables, for outer cone system terminals type B

Cellplux elbow separable cable connectors CWS are suitable for connecting all polymeric-insulated 1-core cables (PVC, PE, XLPE, EPR), with different types of semi-conductive layers (graphite-coated or strippable) and screen design (wire or tape screen), to switching equipment and transformers having an outer cone system type B, up to maximum network voltage of 36 kV in accordance with EN 50180 and EN 50181.

### Characteristics

- With capacitive measuring point
- Individually tested
- Outer semi-conductive layer made of semi-conductive EPDM provides protection from exposed electrical parts
- Cable sheath insulation fault test may be performed while under voltage
- For copper and aluminium conductors
- Quick, safe and easy assembly
- Suitable for a wide range of applications due to integrated screw cable lug

### Application/Suitability

- Indoor
- Voltage level**
- $U_0/U_m$  (U<sub>m</sub>) 6/10 (12) kV - 19/33 (36) kV

### Test standards

- CENELEC HD 629.1 (DIN VDE 0278, part 629-1)

### Storage conditions/Shelf life

- Unlimited shelf life



### Dimensions

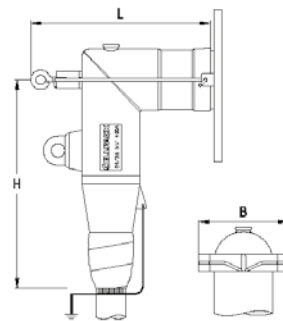

### Scope of delivery

Set of 3 separable cable connectors, silicone stress control elements, earthing set, screw cable lug for main conductor, assembly material, assembly instructions

Optional accessory: EGA earthing kit for cables with tape screen (see Connecting technology)

Type	L mm	B mm	H mm	min. Ø over core insulation after removal of the outer conductive layer mm	12 kV	17.5 kV	24 kV	36 kV	Art.-No.	
					Nominal cross section mm <sup>2</sup>					
<b><math>U_0/U_m</math> (U<sub>m</sub>) 6/10 (12) kV - 12.7/22 (24) kV</b>										
<b>CWS 400A 24kV</b>	25-70 EGA	215	107	250	14.7	50 - 95	25 - 95	25 - 70		250720
	95-240 EGA	215	107	250	22.0	150 - 240	120 - 240	95 - 240		246176
<b><math>U_0/U_m</math> (U<sub>m</sub>) 12/20 (24) kV - 19/33 (36) kV</b>										
<b>CWS 400A 36kV</b>	50-95 EGA	215	107	250	22.0			95 - 95	35 - 95	250726
	150-240 EGA	215	107	250	30.8			240 - 240	150 - 240	247102

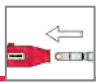

## CTS 630A

### T-shaped separable connector

for all 1-core polymeric cables, for outer cone system terminals type C

Cellplux screwable T-shaped separable connectors CTS are suitable for connecting all polymeric-insulated 1-core cables (PVC, PE, XLPE, EPR), with different types of semi-conductive layers (graphite-coated or strippable) and screen design (wire or tape screen) to switching equipment and transformers having an outer cone system type C, up to maximum network voltage of 36 kV in accordance with EN 50180 and EN 50181.

#### Characteristics

- With capacitive measuring point
- Individually tested
- Outer semi-conductive layer made of semi-conductive EPDM provides protection from exposed electrical parts
- Cable sheath insulation fault test may be performed while under voltage
- For copper and aluminium conductors
- Quick, safe and easy assembly
- Suitable for a wide range of applications due to integrated screw cable lug

#### Application/Suitability

- Indoor
- Voltage level**
- $U_0/U_m$  (U<sub>m</sub>) 6/10 (12) kV - 19/33 (36) kV

#### Test standards

- CENELEC HD 629.1 (DIN VDE 0278, part 629-1)

#### Storage conditions/Shelf life

- Unlimited shelf life



#### Dimensions

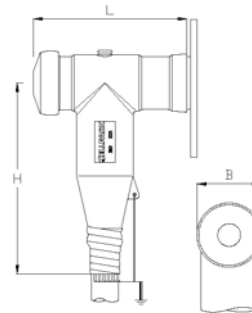

#### Scope of delivery

Set of 3 separable cable connectors, silicone stress control elements, earthing set, screw cable lug for main conductor, screw cable lug for wire screen, assembly material, assembly instructions

Optional accessory: EGA earthing kit for cables with tape screen (see Connecting technology)

Note: Other T-separable cable connectors available on request.

Type	L mm	B mm	H mm	min. Ø over core insulation after removal of the outer conductive layer mm	12 kV	17.5 kV	24 kV	36 kV	Art.-No.	
					Nominal cross section mm <sup>2</sup>					
<b><math>U_0/U_m</math> (U<sub>m</sub>) 6/10 (12) kV - 12.7/22 (24) kV</b>										
CTS 630A 24kV	25-70 EGA	194	85	250	14.7	50 - 95	25 - 95	25 - 70		250711
	95-240 EGA	194	85	250	22.0	150 - 240	120 - 240	95 - 240		220775
	240-300 EGA	194	85	250	23.7	240 - 400	240 - 300	240 - 300		302732
<b><math>U_0/U_m</math> (U<sub>m</sub>) 12/20 (24) kV - 19/33 (36) kV</b>										
CTS 630A 36kV	50-95 EGA	194	85	250	22.0			95 - 95	35 - 95	250715
	95-150 EGA	194	85	250	22.0			95 - 240	95 - 150	256010
	150-240 EGA	194	85	250	30.8			240 - 240	150 - 240	224826
	240-400 EGA	194	85	265	31.5			300 - 400	240 - 400	256328



## CTS 1250A T-shaped separable connector

for all 1-core polymeric cables, for outer cone system terminals type C

Cellpack screwable T-shaped separable connectors CTS are suitable for connecting all polymeric-insulated 1-core cables (PVC, PE, XLPE, EPR), with different types of semi-conductive layers (graphite-coated or strippable) and screen design (wire or tape screen) to switching equipment and transformers having an outer cone system type C, up to maximum network voltage of 36 kV in accordance with EN 50180 and EN 50181.

### Characteristics

- With capacitive measuring point
- Individually tested
- Outer semi-conductive layer made of semi-conductive EPDM provides protection from exposed electrical parts
- Cable sheath insulation fault test may be performed while under voltage
- For copper and aluminium conductors
- Quick, safe and easy assembly
- Suitable for a wide range of applications due to integrated screw cable lug

### Application/Suitability

- Indoor
- Voltage level
- $U_0/U_m$  6/10 (12) kV - 19/33 (36) kV

### Test standards

- CENELEC HD 629.1 (DIN VDE 0278, part 629-1)

### Storage conditions/Shelf life

- Unlimited shelf life



### Dimensions

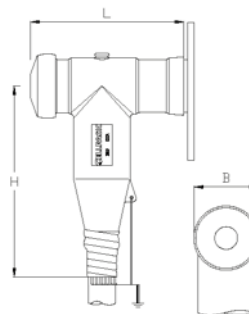

### Scope of delivery

Set of 3 separable cable connectors, silicone stress control elements, earthing set, screw cable lug for main conductor, screw cable lug for wire screen, assembly material, assembly instructions

Optional accessory: EGA earthing kit for cables with tape screen (see Connecting technology)

Note: Other T-separable cable connectors available on request.

Type	L mm	B mm	H mm	min. Ø over core insulation after removal of the outer conductive layer mm	12 kV	17.5 kV	24 kV	36 kV	Art.-No.	
					Nominal cross section mm <sup>2</sup>					
$U_0/U_m$ 6/10 (12) kV - 12.7/22 (24) kV										
CTS 1250A 24kV	400-630	EGA M12 KS	205	87	310	33.4	500 - 630	400 - 630	400 - 630	309283
$U_0/U_m$ 12/20 (24) kV - 19/33 (36) kV										
CTS 1250A 36kV	400-630	EGA M12 KS	205	87	310	39.1		630	400 - 630	309284

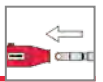

## CTKS 630A

### T-shaped separable coupling connector

for all 1-core polymeric cables, for separable connector type CTS

Cellpack T-shaped separable coupling connectors CTKS are suitable for connecting all polymeric-insulated 1-core cables (PVC, PE, XLPE, EPR), with different types of semi-conductive layers (graphite-coated or strippable) and screen design (wire or tape screen) to the back of T-shaped separable connectors type CTS.

#### Characteristics

- With capacitive measuring point
- Individually tested
- Outer semi-conductive layer made of semi-conductive EPDM provides protection from exposed electrical parts
- Cable sheath insulation fault test may be performed while under voltage
- For copper and aluminium conductors
- Quick, safe and easy assembly
- Suitable for a wide range of applications due to integrated screw cable lug

#### Application/Suitability

- Indoor
- Voltage level**
  - $U_0/U_m$  6/10 (12) kV - 19/33 (36) kV
- Test standards**
  - CENELEC HD 629.1 (DIN VDE 0278, part 629-1)
- Storage conditions/Shelf life**
  - Unlimited shelf life



#### Dimensions

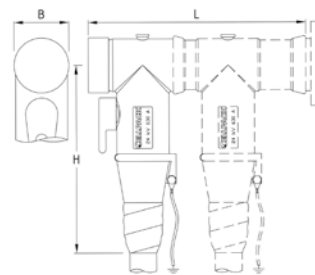

#### Scope of delivery

Set of 3 separable coupling connectors, silicone stress control elements, earthing set, screw cable lug for main conductor, assembly material, assembly instructions

Optional accessory: EGA earthing kit for cables with tape screen (see Connecting technology)

Type	L mm	B mm	H mm	min. Ø over core insulation after removal of the outer conductive layer mm	12 kV	17.5 kV	24 kV	36 kV	Art.-No.	
					Nominal cross section mm <sup>2</sup>					
<b><math>U_0/U_m</math> 6/10 (12) kV - 12.7/22 (24) kV</b>										
CTKS 630A 24kV	25-70 EGA	290	74	250	14.7	50 - 95	25 - 95	25 - 70		256838
	95-240 EGA	290	74	250	22.0	150 - 240	120 - 240	95 - 240		256839
<b><math>U_0/U_m</math> 12/20 (24) kV - 19/33 (36) kV</b>										
CTKS 630A 36kV	50-95	310	85	250	22.0			95 - 95	35 - 95	257581
	150-240	310	85	250	30.8			240 - 240	150 - 240	257582



# CTKSA Coupling surge arrester

Class 1, for separable connector type CTS

Cellpack coupling surge arresters CTKSA / Class 1 are suitable for the protection of encapsulated medium voltage installations with a maximum operating voltage of  $U_0 = 24$  kV. The compact design allows direct connection to double-row CTS T-shaped separable connectors, in accordance with International Standard IEC 60099-4.

### Characteristics

- With capacitive measuring point
- Individually tested
- Outer semi-conductive layer made of semi-conductive EPDM provides protection from exposed electrical parts
- Quick, safe and easy assembly

### Application/Suitability

- Indoor
- Storage conditions/Shelf life**
- Unlimited shelf life



### Scope of delivery

Set of 3 surge arresters, assembly material, assembly instructions

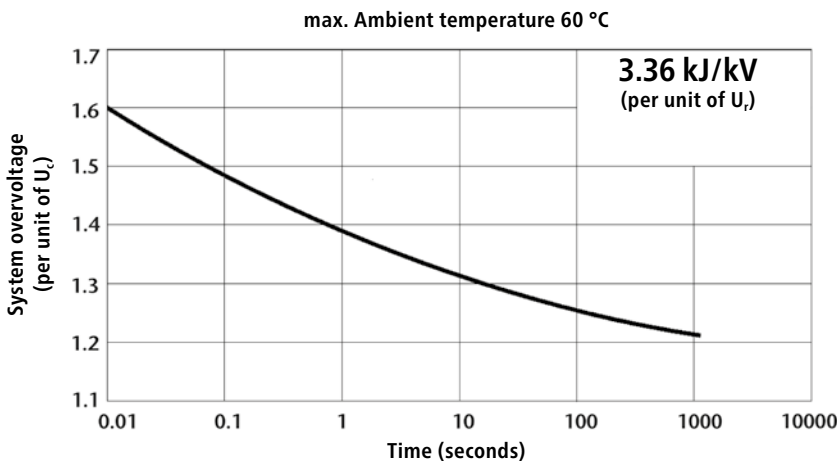

### Dimensions

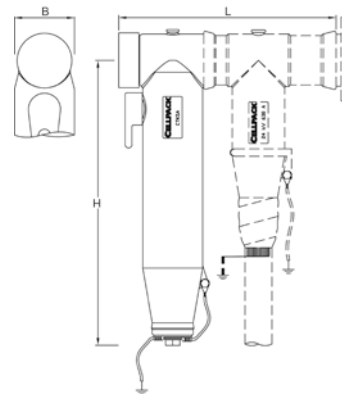

Type		L mm	B mm	H mm	Art.-No.
CTKSA	12kV	290	80	380	262054
	17kV	290	80	380	262055
	19.5kV	290	80	380	262816
	24kV	290	80	380	262056

Technical data	CTKSA 12 kV	CTKSA 17 kV	CTKSA 19.5 kV	CTKSA 24 kV
Nominal leakage current I [kA]	10	10	10	10
Rated voltage U <sub>r</sub> [kV]	15.0	21.0	24.0	30.0
max. Operating voltage U <sub>c</sub> [kV]	12.7	17.0	19.5	24.0
Partial discharge at U <sub>c</sub> [pC]	< 5	< 5	< 5	< 5
Residual voltage [kV] at:				
Steep current impulse 1/20 μs	53.0	74.2	84.8	105.9
Switching impulse current 125 A	35.8	50.1	57.3	71.7
Switching impulse current 500 A	38.2	53.5	61.2	76.5
Lightning impulse current 8/20 μs	49.5	69.3	79.2	99.0



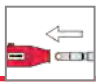

# CTKSA Coupling surge arrester

Class 2, for separable connector type CTS

Cellpack coupling surge arresters CTKSA / Class 2 are suitable for the protection of encapsulated medium voltage installations with a maximum operating voltage of  $U_0 = 34$  kV. The compact design allows direct connection to double-row CTS T-shaped separable connectors, in accordance with International Standard IEC 60099-4.

### Characteristics

- With capacitive measuring point
- Individually tested
- Outer semi-conductive layer made of semi-conductive EPDM provides protection from exposed electrical parts
- Quick, safe and easy assembly

### Application/Suitability

- Indoor
- Storage conditions/Shelf life**
- Unlimited shelf life



### Scope of delivery

Set of 3 surge arresters, assembly material, assembly instructions

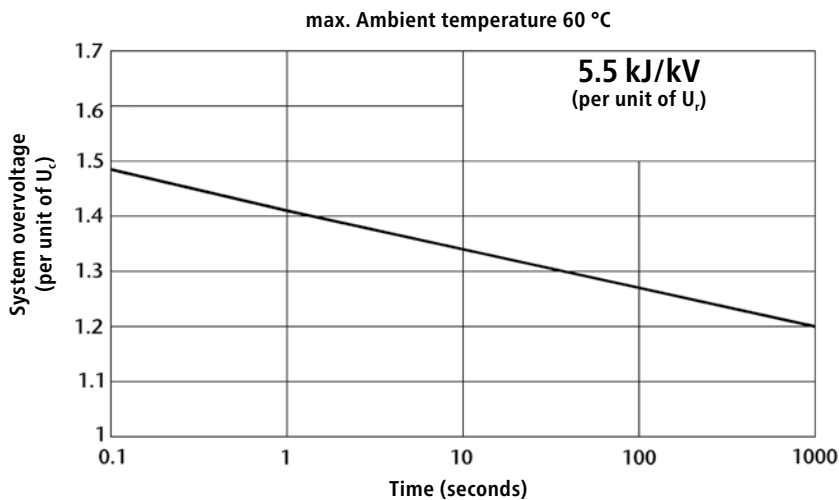

### Dimensions

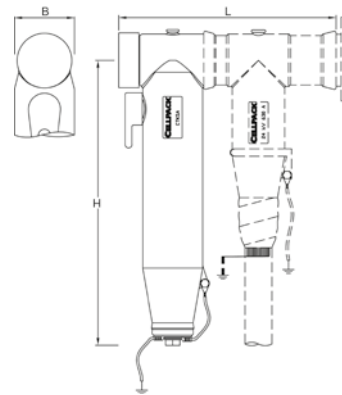

Type		L mm	B mm	H mm	Art.-No.
CTKSA	34kV	290	80	380	301492

Technical data	CTKSA 34 kV
Nominal leakage current I [kA]	10
Rated voltage U <sub>r</sub> [kV]	42.0
max. Operating voltage U <sub>0</sub> [kV]	34.0
Partial discharge at U <sub>c</sub> [pC]	< 5
<b>Residual voltage [kV] at:</b>	
Steep current impulse 1/20 μs	120.4
Switching impulse current 125 A	84.0
Switching impulse current 500 A	89.6
Lightning impulse current 8/20 μs	108.5

MEDIUM VOLTAGE  
Cable sets for screened polymeric cables



## ZS-CTS

### Accessory kit

for separable connectors type CTS

The ZS-CTS accessory set is designed for the reinstallation of T-shaped separable connectors CTS to switching equipment and transformers having an outer cone system type C, in accordance with EN 50180 and EN 50181. This set includes the proven and tested contact pin with shear head bolt, which eliminates the possibility of faulty assembly of the cable systems.

#### Characteristics

- Easy assembly

#### Application/Suitability

- Re-installation of type CTS separable connectors



#### Scope of delivery

Set of 3 contact pins with shear head bolt, assembly material, assembly instructions

Type	Art.-No.
ZS-CTS	257622

MEDIUM VOLTAGE  
Cable sets for screened polymeric cables

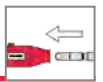

## CIK

### Voltage-resistant insulating cap

for plug-in connections type A 250A and type C 630A

The voltage-resistant insulating caps CIK are suitable for electrical insulations of outer cones type A 250A and type C 630A on encapsulated switching equipment and transformers up to 36 kV, in accordance with EN 50180 and EN 50181.

#### Characteristics

- Submersible
- Outer semi-conductive layer made of semi-conductive EPDM provides protection from exposed electrical parts
- Easy assembly

#### Application/Suitability

- Indoor
- Outdoor

#### Voltage level

- $U_0/U (U_m)$  6/10 (12) kV - 19/33 (36) kV

#### Storage conditions/Shelf life

- Unlimited shelf life



#### Scope of delivery

Set of 3 voltage resistant insulating caps, assembly material, assembly instructions

Type	Art.-No.
$U_0/U (U_m)$ 6/10 (12) kV - 12.7/22 (24) kV	
<b>CIK 250A 24kV</b>	<b>265023</b>
$U_0/U (U_m)$ 6/10 (12) kV - 19/33 (36) kV	
<b>CIK 630A 36kV</b>	<b>265024</b>



## Mounting ring

### Assembly guide for CWS 250A and CGS 250A

for plug-in connections type A

The mounting ring is suitable to secure the Cellplux separable cable connectors CWS 250A and CGS 250A to a special plug-in connection with outer cone systems type A. It is simply placed in the prefabricated groove in the cable connector. The two components may then be mounted on the bushing together.

#### Characteristics

- Secure connection to special Type A bushing
- Easy assembly

#### Application/Suitability

- Indoor
- #### Storage conditions/Shelf life
- Unlimited shelf life



Scope of delivery  
Mounting ring

Type	Art.-No.
Mounting ring	264366

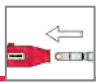

## CVS 250A

### Connecting element up to 24 kV

for separable cable connectors type CWS and type CGS, for outer cone system terminals type A

The connecting element CVS is suitable for connecting two elbow separable cable connectors type CWS 250A and/or straight separable cable connectors CGS up to 24 kV. Its dimensions correspond to outer cone systems type A, in accordance with EN 50180 and EN 50181.

#### Characteristics

- Individually tested
- Safe and easy to handle
- Easy assembly

#### Application/Suitability

- Indoor
- Voltage level**
- $U_0/U_m$  6/10 (12) kV - 12.7/22 (24) kV
- Storage conditions/Shelf life**
- Unlimited shelf life



#### Scope of delivery

Set of 3 connecting elements, assembly material, assembly instructions

#### Dimensions

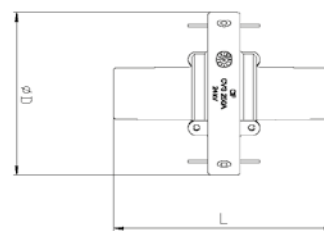

Type	L mm	Ø D mm	Art.-No.
$U_0/U_m$ 6/10 (12) kV - 12.7/22 (24) kV			
CVS 250A 24kV	136	100	225844



## CKS 630A Coupling element up to 36 kV

for T-shaped separable connectors type CTS

The coupling element CKS is suitable for connecting two T-shaped separable connectors CTS up to 36 kV. The dimensions of the longer outer cone correspond to the outer cone systems type C, in accordance with EN 50180 and EN 50181.

### Characteristics

- Individually tested
- Safe and easy to handle
- Easy assembly

### Application/Suitability

- Indoor

### Voltage level

- $U_0/U_m$  (U<sub>m</sub>) 6/10 (12) kV - 19/33 (36) kV

### Storage conditions/Shelf life

- Unlimited shelf life



### Scope of delivery

Set of 3 coupling elements, assembly material, assembly instructions

### Dimensions

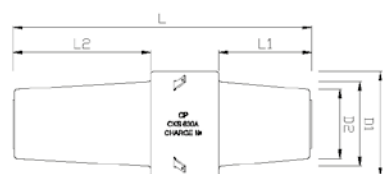

D = Outer diameter

Type	L mm	L1 mm	L2 mm	D mm	D1 mm	D2 mm	Art.-No.
$U_0/U_m$ (U <sub>m</sub> ) 6/10 (12) kV - 19/33 (36) kV							
<b>CKS 630A 36kV</b>	196.5	61.5	91	70	56	46	224853

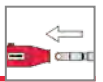

## CPES

### Test and earthing kit

for Cellplux separable cable connectors type CTS and type CTKS

The test and earthing kit CPES is suitable for the establishment of galvanic connections between cable conductors and ground. The CPES is compatible with all Cellplux T-shaped separable connectors CTS and T-shaped separable coupling connectors CTKS.

#### Characteristics

- Safe and easy to handle

#### Application/Suitability

- Cable testing
- Cable fault location
- Earthing for work
- Phase comparison

#### Voltage level

- $U_0/U (U_m)$  6/10 (12) kV - 19/33 (36) kV



#### Scope of delivery

Chest, test adapter, set of 3 earthing adapters, assembly material, assembly instructions

Type	Art.-No.
$U_0/U (U_m)$ 6/10 (12) kV - 19/33 (36) kV	
CPES	259101



## CPS Test kit

for Cellplux separable cable connectors type CTS and type CTKS

The test kit CPS is suitable for the establishment of galvanic connections between cable conductors and is compatible with all Cellplux T-shaped separable connectors CTS and T-shaped separable coupling connectors CTKS.

### Characteristics

- Safe and easy to handle

### Application/Suitability

- Cable testing
- Cable fault location
- Phase comparison

### Voltage level

- $U_0/U_m$  6/10 (12) kV - 19/33 (36) kV



### Scope of delivery

Chest, set of 3 test adapters, assembly material, assembly instructions

Type	Art.-No.
$U_0/U_m$ 6/10 (12) kV - 19/33 (36) kV	
CPS	302227





## CHMSV3

### 3-core straight-through joint

with screw connectors, for all 3-core polymeric cables

Hybrid straight-through joints CHMSV3 are suitable for all 3-core polymeric-insulated cables (PVC, PE, XLPE, EPR). They allow the connection of cables with copper wire screen with different cross sections and conductor materials even with different cable designs concerning the semi-conductive layer (graphite-coated, removable or strippable). With screw connectors.

#### Characteristics

- Reliable stress control due to flexible silicone stress control elements
- For both copper and aluminium conductors
- For all cables with copper wire screen
- Wide conductor and cross-section range
- Quick, safe and easy assembly
- Ready for immediate operation
- Suitable for a wide range of applications due to integrated screw connector

#### Application/Suitability

- Indoor
- Outdoor
- Underground
- Water
- Installation ducts
- Ductwork

#### Voltage level

- $U_0/U_m$  6/10 (12) kV - 19/33 (36) kV

#### Test standards

- CENELEC HD 629.1  
(DIN VDE 0278, part 629-1)

#### Storage conditions/Shelf life

- Unlimited shelf life



Dimensions



#### Scope of delivery

Thick wall heat shrinkable insulation tubes, thick wall heat shrinkable outer tube with hot melt adhesive, silicone stress control element, copper braid tape, field control filling tape (blue), innovative screw connectors with conductive cover, screw connector for copper-wire screen, assembly material, assembly instructions

Note: Straight-through joints with larger cross-section available on request.

Type	L mm	min. Ø over core insulation after removal of the outer conductive layer mm	12 kV	17.5 kV	24 kV	36 kV	Art.-No.
			Nominal cross section mm <sup>2</sup>				
$U_0/U_m$ 6/10 (12) kV - 6.35/11 (12) kV							
CHMSV3 12kV	25-95	1050	12.6	25 - 95			297348
	70-150	1050	14.7	70 - 150			297350
	95-240	1100	17.3	95 - 240			297260
	240-400	1250	23.1	240 - 400			297358
$U_0/U_m$ 8.7/15 (17.5) kV							
CHMSV3 17kV	25-95	1050	14.7	25 - 95			297349
	70-150	1050	18.0	70 - 150			297351
	95-240	1100	19.9	95 - 240			297310
	240-400	1250	24.0	240 - 400			297360
$U_0/U_m$ 12/20 (24) kV - 12.7/22 (24) kV							
CHMSV3 24kV	16-95	1050	14.7		16 - 95		297433
	50-150	1050	17.3		50 - 150		297352
	95-240	1100	19.9		95 - 240		297104
	240-400	1250	27.3		240 - 400		297361
$U_0/U_m$ 18/30 (36) kV - 19/33 (36) kV							
CHMSV3 36kV	50-150	1050	20.9			50 - 150	297353
	95-240	1100	24.2			95 - 240	297311
	240-400	1250	32.0			240 - 400	297362



# CHMSV3-1 Straight-through joint

with screw connectors, for connecting from 3-core with 1-core polymeric cables

Hybrid straight-through joints CHMSV3-1 are suitable for connecting 3-core polymeric cables with three 1-core polymeric cables (PVC, PE, XLPE, EPR). They allow the connection of cables with copper wire screen with different cross sections and conductor materials even with different cable designs concerning the semi-conductive layer (graphite-coated, removable or strippable). With screw connectors.

### Characteristics

- Reliable stress control due to flexible silicone stress control elements
- For both copper and aluminium conductors
- For all cables with copper wire screen
- Wide conductor and cross-section range
- Quick, safe and easy assembly
- Ready for immediate operation
- Suitable for a wide range of applications due to integrated screw connector

### Application/Suitability

- Indoor
- Outdoor
- Underground
- Water
- Installation ducts
- Ductwork

### Voltage level

- $U_0/U_m$  6/10 (12) kV - 19/33 (36) kV

### Test standards

- CENELEC HD 629.1 (DIN VDE 0278, part 629-1)

### Storage conditions/Shelf life

- Unlimited shelf life



Dimensions



### Scope of delivery

Thick wall heat shrinkable insulation tubes, thick wall heat shrinkable outer tube with hot melt adhesive, silicone stress control element, copper braid tape, field control filling tape (blue), innovative screw connectors with conductive cover, screw connector for copper-wire screen, assembly material, assembly instructions

Note: Straight-through joints with larger cross-section available on request.

Type	L mm	min. Ø over core insulation after removal of the outer conductive layer mm	12 kV	17.5 kV	24 kV	36 kV	Art.-No.
			Nominal cross section mm <sup>2</sup>				
<b><math>U_0/U_m</math> 6/10 (12) kV - 6.35/11 (12) kV</b>							
CHMSV3-1 12kV	25-95	900	12.6	25 - 95			297449
	70-150	900	14.7	70 - 150			297462
	95-240	900	17.3	95 - 240			297442
	240-400	1000	23.1	240 - 400			297466
<b><math>U_0/U_m</math> 8.7/15 (17.5) kV</b>							
CHMSV3-1 17kV	25-95	900	14.7	25 - 95			297460
	70-150	900	18.0	70 - 150			297463
	95-240	900	19.9	95 - 240			297443
	240-400	1000	24.0	240 - 400			297467
<b><math>U_0/U_m</math> 12/20 (24) kV - 12.7/22 (24) kV</b>							
CHMSV3-1 24kV	16-95	900	14.7		16 - 95		297461
	50-150	900	17.3		50 - 150		297464
	95-240	900	19.9		95 - 240		297441
	240-400	1000	27.3		240 - 400		297468
<b><math>U_0/U_m</math> 18/30 (36) kV - 19/33 (36) kV</b>							
CHMSV3-1 36kV	50-150	900	20.9			50 - 150	297465
	95-240	900	24.2			95 - 240	297444
	240-400	1000	32.0			240 - 400	297469

MEDIUM VOLTAGE  
Cable sets for screened polymeric cables



## CHM3

### 3-core straight-through joint

for all 3-core polymeric cables

Hybrid straight-through joints CHM3 are suitable for all 3-core polymeric-insulated cables (PVC, PE, XLPE, EPR). They allow the connection of cables with different cross sections and conductor materials even with different cable designs concerning the semi-conductive layer (graphite-coated, removable or strippable) and screen design (copper wire or tape screen). Suitable for compression connectors.

#### Characteristics

- Reliable stress control due to flexible silicone stress control elements
- Wide conductor and cross-section range
- Quick, safe and easy assembly
- Ready for immediate operation

#### Application/Suitability

- Indoor
- Outdoor
- Underground
- Water
- Installation ducts
- Ductwork

#### Voltage level

- $U_0/U_m$  6/10 (12) kV - 19/33 (36) kV

#### Note

- 12 kV joints must be used for 7.2 kV cables. (Check minimum diameter over conductor insulation.)

#### Test standards

- CENELEC HD 629.1  
(DIN VDE 0278, part 629-1)

#### Storage conditions/Shelf life

- Unlimited shelf life



Dimensions



#### Scope of delivery

Thick wall heat shrinkable insulation tubes, thick wall heat shrinkable outer tube with hot melt adhesive, silicone stress control element, copper braid tube, pressure springs, field control filling tape (blue), assembly material, assembly instructions

Optional accessory: Compression connectors (see Connecting technology)

Note: Straight-through joints with larger cross-section available on request.

Type	L mm	min. Ø over core insulation after removal of the outer conductive layer mm	max. Conne- ctor- Ø mm	max. Conne- ctor length mm	12 kV	17.5 kV	24 kV	36 kV	Art.-No.	
					Nominal cross section mm <sup>2</sup>					
$U_0/U_m$ 6/10 (12) kV - 6.35/11 (12) kV										
CHM3 12kV	10-25	1200	9.9	16	90	10 - 25				194293
	35-95	1200	12.6	25	135	35 - 95				194294
	95-240	1200	17.3	32	145	95 - 240				194295
	150-300	1200	19.9	40	200	150 - 300				194296
$U_0/U_m$ 8.7/15 (17.5) kV										
CHM3 17kV	35-95	1200	12.6	25	135		35 - 95			194297
	70-240	1200	17.3	32	145		70 - 240			194298
	120-300	1200	19.9	34	150		120 - 300			194299
	240-400	1200	23.1	40	200		240 - 400			194300
$U_0/U_m$ 12/20 (24) kV - 12.7/22 (24) kV										
CHM3 24kV	10-35	1200	12.6	20	100			10 - 35		194301
	50-150	1200	17.3	25	135			50 - 150		194302
	70-240	1200	19.9	32	145			70 - 240		194303
	150-300	1200	23.1	40	200			150 - 300		194304
$U_0/U_m$ 18/30 (36) kV - 19/33 (36) kV										
CHM3 36kV	35-70	1200	19.9	20	110			35 - 70		194305
	50-150	1200	23.1	25	135			50 - 150		194306
	150-300	1200	27.3	38	200			150 - 300		194307



## CAM3-S 3-core straight-through joint

for all 3-core polymeric cables

Straight-through joints CAM3-S are suitable for all 3-core polymeric-insulated cables (PVC, PE, XLPE, EPR). They allow the connection of cables with different cross sections and conductor materials even with different cable designs concerning the semi-conductive layer (graphite-coated, removable or strippable) and screen design (wire or tape screen). Suitable for compression connectors.

### Characteristics

- Reliable stress control due to flexible silicone stress control elements
- Wide conductor and cross-section range
- Quick, safe and easy assembly
- Ready for immediate operation

### Application/Suitability

- Indoor
- Outdoor
- Underground
- Water
- Installation ducts
- Ductwork

### Voltage level

- $U_0/U_m$  6/10 (12) kV - 12.7/22 (24) kV

### Note

- 12 kV joints must be used for 7.2 kV cables. (Check minimum diameter over conductor insulation.)

### Storage conditions/Shelf life

- Unlimited shelf life

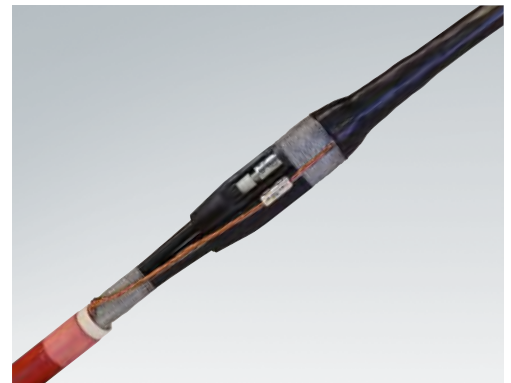

Dimensions



### Scope of delivery

Thick wall heat shrinkable outer tube with hot melt adhesive, silicone stress control elements, silicone joint unit with integrated semi-conductive layer (individually tested), copper braid tube, pressure spring, lubricant, assembly instructions

Optional accessory: Compression connectors (see Connecting technology)

Type	L mm	min. Ø over core insulation after removal of the outer conductive layer mm	max. Connector length mm	Nominal cross section mm <sup>2</sup>			Art.-No.
				12 kV	17.5 kV	24 kV	
$U_0/U_m$ 6/10 (12) kV - 6.35/11 (12) kV							
CAM3-S 12kV	50-240	1200	14.7	50 - 240			201375
	150-400	1200	19.9	150 - 400			201377
$U_0/U_m$ 8.7/15 (17.5) kV							
CAM3-S 17kV	35-150	1200	14.7		35 - 150		201379
	95-300	1200	19.9		95 - 300		201381
$U_0/U_m$ 6/10 (12) kV - 12.7/22 (24) kV							
CAM3-S 24kV	16-120	1200	14.7			16 - 120	201382
	70-240	1200	19.9			70 - 240	201374



## CHESK-3I(A) **NEW**

### 3-core indoor cable termination

with screw cable lugs, for all 3-core polymeric cables

Hybrid cable terminations CHESK-3I(A) are suitable for all 3-core polymeric-insulated cables (PVC, PE, XLPE, EPR) with different types of semi-conductive layers (graphite-coated, removable or strippable) and screen design (copper wire or tape). With screw cable lugs.

#### Characteristics

- Flexible silicone stress control elements ensure reliable stress control under all operating conditions
- Combination of slip-on and heat shrinkable components
- Wide cross-section range
- Quick, safe and easy assembly
- Ready for immediate operation

#### Application/Suitability

- Indoor
- #### Voltage level
- $U_0/U (U_m)$  6/10 (12) kV - 19/33 (36) kV

#### Note

- 12 kV cable terminations must be used for 7.2 kV cables. (Check minimum diameter over conductor insulation.)

#### Test standards

- CENELEC HD 629.1 (DIN VDE 0278, part 629-1)

#### Storage conditions/Shelf life

- Unlimited shelf life



#### Dimensions

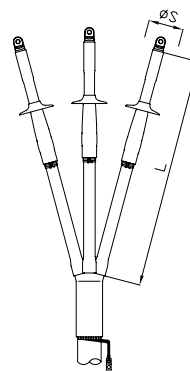

Ø S = Diameter of cable shed

#### Scope of delivery

Spreader cap, heat shrinkable tube (tracking resistant), heat shrinkable tube, silicone stress control elements, silicone sheds, pressure spring, sealing tape, screw cable lugs, assembly material, assembly instructions

Optional accessory: EGA earthing kit for cables with tape screen (see Connecting technology)

Type	L mm	min. Ø over core insulation after removal of the outer conductive layer mm	Number of sheds per phase	Ø S mm	Nominal cross section mm <sup>2</sup>				Art.-No.
					12 kV	17.5 kV	24 kV	36 kV	
$U_0/U (U_m)$ 6/10 (12) kV - 6.35/11 (12) kV									
CHESK-3I(A) 12kV	25-95	600	12.6		25 - 95				309800
	95-240	600	17.3		95 - 240				309801
	240-400	600	19.9		240 - 400				309802
$U_0/U (U_m)$ 12/20 (24) kV - 12.7/22 (24) kV									
CHESK-3I(A) 24kV	25-95	600	17.3	1	85	25 - 95	25 - 95		309806
	95-240	600	19.9	1	85	95 - 240	95 - 240		309807
	240-400	600	27.3	1	115	240 - 400	240 - 400		309808
$U_0/U (U_m)$ 18/30 (36) kV - 19/33 (36) kV									
CHESK-3I(A) 36kV	25-95	800	19.9	2	85			25 - 95	309810
	95-240	800	23.1	2	85			95 - 240	309811
	240-400	800	27.3	2	115			240 - 400	309812



## CHE-3I(A) 3-core indoor cable termination

for all 3-core polymeric cables

Hybrid cable terminations CHE-3I(A) are suitable for all 3-core polymeric-insulated cables (PVC, PE, XLPE, EPR) with different types of semi-conductive layers (graphite-coated, removable or strippable) and screen design (copper wire or tape). Suitable for compression or screw cable lugs.

### Characteristics

- Flexible silicone stress control elements ensure reliable stress control under all operating conditions
- Combination of slip-on and heat shrinkable components
- Wide cross-section range
- Quick, safe and easy assembly
- Ready for immediate operation

### Application/Suitability

- Indoor

### Voltage level

- $U_0/U_m$  6/10 (12) kV - 19/33 (36) kV

### Note

- 12 kV cable terminations must be used for 7.2 kV cables. (Check minimum diameter over conductor insulation.)

### Test standards

- CENELEC HD 629.1 (DIN VDE 0278, part 629-1)

### Storage conditions/Shelf life

- Unlimited shelf life



### Dimensions

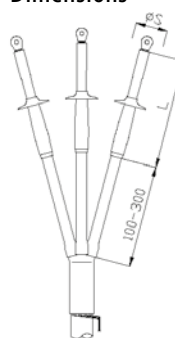

Ø S = Diameter of cable shed

### Scope of delivery

Spreader cap, heat shrinkable tube (tracking resistant), heat shrinkable tube, silicone stress control elements, silicone sheds, pressure spring, sealing tape, assembly material, assembly instructions

Optional accessory: Cable lugs (see Connecting technology)

EGA earthing kit for cables with tape screen (see Connecting technology)

Note: Other cable terminations available on request.

Type	L mm	min. Ø over core insulation after removal of the outer conductive layer mm	Number of sheds per phase	Ø S mm	12 kV	17.5 kV	24 kV	36 kV	Art.-No.
					Nominal cross section mm <sup>2</sup>				
<b><math>U_0/U_m</math> 6/10 (12) kV - 6.35/11 (12) kV</b>									
<b>CHE-3I(A) 12kV</b>	10-25	300	9.9		10 - 25				146228
	25-95	300	12.6		25 - 95				146216
	95-240	300	17.3		95 - 240				146217
	150-400	300	19.9		150 - 400				146218
<b><math>U_0/U_m</math> 8.7/15 (17.5) kV</b>									
<b>CHE-3I(A) 17kV</b>	16-50	300	12.6	1	85	16 - 50			195365
	70-240	300	17.3	1	85	70 - 240			171761
	150-300	300	19.9	1	85	150 - 300			171762
	185-400	300	23.1	1	85	185 - 400			171763
<b><math>U_0/U_m</math> 12/20 (24) kV - 12.7/22 (24) kV</b>									
<b>CHE-3I(A) 24kV</b>	10-35	300	12.6	1	85		10 - 35		146300
	25-95	300	17.3	1	85		25 - 95		146302
	70-240	300	19.9	1	85		70 - 240		146301
	120-300	300	23.1	1	85		120 - 300		146297
<b><math>U_0/U_m</math> 18/30 (36) kV - 19/33 (36) kV</b>									
<b>CHE-3I(A) 36kV</b>	35-70	500	19.9	2	85			35 - 70	146158
	50-150	500	23.1	2	85			50 - 150	146159
	150-400	500	27.3	2	115			150 - 400	146160



## CHE-3I(B) 3-core indoor cable termination

for all 3-core polymeric cables

Hybrid cable terminations CHE-3I(B) are suitable for all 3-core polymeric-insulated cables (PVC, PE, XLPE, EPR) with different types of semi-conductive layers (graphite-coated, removable or strippable) and screen design (copper wire or tape). Suitable for compression or screw cable lugs.

### Characteristics

- Flexible silicone stress control elements ensure reliable stress control under all operating conditions
- Combination of slip-on and heat shrinkable components
- Wide cross-section range
- Quick, safe and easy assembly
- Ready for immediate operation

### Application/Suitability

- Indoor
- Voltage level**
- $U_0/U_m$  6/10 (12) kV - 19/33 (36) kV

### Note

- 12 kV cable terminations must be used for 7.2 kV cables. (Check minimum diameter over conductor insulation.)

### Test standards

- CENELEC HD 629.1  
(DIN VDE 0278, part 629-1)

### Storage conditions/Shelf life

- Unlimited shelf life



### Dimensions

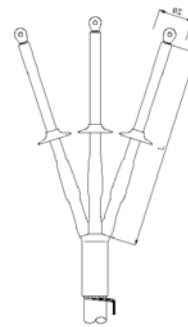

Ø S = Diameter of cable shed

### Scope of delivery

Spreader cap (tracking resistant), heat shrinkable tube (tracking resistant), silicone stress control elements, silicone sheds, pressure spring, sealing tape, assembly material, assembly instructions

Optional accessory: Cable lugs (see Connecting technology)  
EGA earthing kit for cables with tape screen (see Connecting technology)

Note: Other cable terminations available on request.

Type	L mm	min. Ø over core insulation after removal of the outer conductive layer mm	Number of sheds per phase	Ø S mm	12 kV	17.5 kV	24 kV	36 kV	Art.-No.
					Nominal cross section mm <sup>2</sup>				
$U_0/U_m$ 6/10 (12) kV - 6.35/11 (12) kV									
CHE-3I(B) 12kV	10-25	350	9.9		10 - 25				184796
	25-95	350	12.6		25 - 95				173134
	95-240	350	17.3		95 - 240				173132
	150-400	350	19.9		150 - 400				180522
$U_0/U_m$ 8.7/15 (17.5) kV									
CHE-3I(B) 17kV	25-50	400	12.6			25 - 50			182731
	70-240	400	17.3			70 - 240			182732
	150-300	400	19.9			150 - 300			182733
	185-400	400	23.1			185 - 400			182734
$U_0/U_m$ 12/20 (24) kV - 12.7/22 (24) kV									
CHE-3I(B) 24kV	10-35	500	12.6	1	85		10 - 35		184797
	25-95	500	17.3	1	85		25 - 95		184798
	70-240	500	19.9	1	85		70 - 240		184799
	120-400	500	23.1	1	85		120 - 400		184800
$U_0/U_m$ 18/30 (36) kV - 19/33 (36) kV									
CHE-3I(B) 36kV	35-70	650	19.9	2	85			35 - 70	184801
	50-150	650	23.1	2	85			50 - 150	184802
	150-400	650	27.3	2	115			150 - 400	184803



# CHESK-3F(A) NEW

## 3-core outdoor cable termination

with screw cable lugs, for all 3-core polymeric cables

Hybrid cable terminations CHESK-3F(A) are suitable for all 3-core polymeric-insulated cables (PVC, PE, XLPE, EPR) with different types of semi-conductive layers (graphite-coated, removable or strippable) and screen design (copper wire or tape). With screw cable lugs.

### Characteristics

- Flexible silicone stress control elements ensure reliable stress control under all operating conditions
- Combination of slip-on and heat shrinkable components
- Wide cross-section range
- Quick, safe and easy assembly
- Ready for immediate operation

### Application/Suitability

- Outdoor

### Voltage level

- $U_0/U (U_m)$  6/10 (12) kV - 19/33 (36) kV

### Note

- 12 kV cable terminations must be used for 7.2 kV cables. (Check minimum diameter over conductor insulation.)

### Test standards

- CENELEC HD 629.1 (DIN VDE 0278, part 629-1)

### Storage conditions/Shelf life

- Unlimited shelf life



### Dimensions

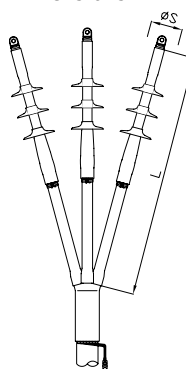

Ø S = Diameter of cable shed

### Scope of delivery

Spreader cap, heat shrinkable tube (tracking resistant), heat shrinkable tube, silicone stress control elements, silicone sheds, pressure spring, sealing tape, screw cable lugs, assembly material, assembly instructions

Optional accessory: EGA earthing kit for cables with tape screen (see Connecting technology)

Type	L mm	min. Ø over core insulation after removal of the outer conductive layer mm	Number of sheds per phase	Ø S mm	Nominal cross section mm <sup>2</sup>				Art.-No.
					12 kV	17.5 kV	24 kV	36 kV	
<b><math>U_0/U (U_m)</math> 6/10 (12) kV - 6.35/11 (12) kV</b>									
CHESK-3F(A) 12kV	25-95	1200	1	80	25 - 95				309813
	95-240	1200	1	85	95 - 240				309815
	240-400	1200	1	85	240 - 400				309816
<b><math>U_0/U (U_m)</math> 12/20 (24) kV - 12.7/22 (24) kV</b>									
CHESK-3F(A) 24kV	25-95	1200	3	85		25 - 95	25 - 95		309820
	95-240	1200	3	85		95 - 240	95 - 240		309821
	240-400	1200	3	115		240 - 400	240 - 400		309822
<b><math>U_0/U (U_m)</math> 18/30 (36) kV - 19/33 (36) kV</b>									
CHESK-3F(A) 36kV	25-95	1200	4	85				25 - 95	309823
	95-240	1200	4	85				95 - 240	309824
	240-400	1200	4	115				240 - 400	309583





## CHE-3F(A) 3-core outdoor cable termination

for all 3-core polymeric cables

Hybrid cable terminations CHE-3F(A) are suitable for all 3-core polymeric-insulated cables (PVC, PE, XLPE, EPR) with different types of semi-conductive layers (graphite-coated, removable or strippable) and screen design (copper wire or tape). Suitable for compression or screw cable lugs.

### Characteristics

- Flexible silicone stress control elements ensure reliable stress control under all operating conditions
- Combination of slip-on and heat shrinkable components
- Wide cross-section range
- Quick, safe and easy assembly
- Ready for immediate operation

### Application/Suitability

- Outdoor

### Voltage level

- $U_0/U_m$  6/10 (12) kV - 19/33 (36) kV

### Note

- 12 kV cable terminations must be used for 7.2 kV cables. (Check minimum diameter over conductor insulation.)

### Test standards

- CENELEC HD 629.1 (DIN VDE 0278, part 629-1)

### Storage conditions/Shelf life

- Unlimited shelf life



### Dimensions

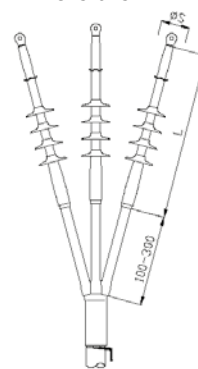

Ø S = Diameter of cable shed

### Scope of delivery

Spreader cap, heat shrinkable tube (tracking resistant), heat shrinkable tube, silicone stress control elements, silicone sheds, pressure spring, sealing tape, assembly material, assembly instructions

Optional accessory: Cable lugs (see Connecting technology)  
EGA earthing kit for cables with tape screen (see Connecting technology)

Note: Other cable terminations available on request.

Type	L mm	min. Ø over core insulation after removal of the outer conductive layer mm	Number of sheds per phase	Ø S mm	12 kV	17.5 kV	24 kV	36 kV	Art.-No.	
					Nominal cross section mm²					
<b><math>U_0/U_m</math> 6/10 (12) kV - 6.35/11 (12) kV</b>										
CHE-3F(A) 12kV	10-25	300	9.9	1	80	10 - 25			146226	
	25-95	300	12.6	1	85	25 - 95			146220	
	95-240	300	17.3	1	85	95 - 240			146222	
	150-400	300	19.9	1	85	150 - 400			146224	
<b><math>U_0/U_m</math> 8.7/15 (17.5) kV</b>										
CHE-3F(A) 17kV	16-50	500	12.6	2	85		16 - 50		195366	
	70-240	500	17.3	2	85		70 - 240		171756	
	150-300	500	19.9	2	85		150 - 300		171757	
	185-400	500	23.1	2	85		185 - 400		146296	
<b><math>U_0/U_m</math> 12/20 (24) kV - 12.7/22 (24) kV</b>										
CHE-3F(A) 24kV	10-35	500	12.6	3	85			10 - 35	146303	
	25-95	500	17.3	3	85			25 - 95	146304	
	70-240	500	19.9	3	85			70 - 240	146306	
	120-300	500	23.1	3	85			120 - 300	146298	
<b><math>U_0/U_m</math> 18/30 (36) kV - 19/33 (36) kV</b>										
CHE-3F(A) 36kV	35-70	700	19.9	4	85				35 - 70	146234
	50-150	700	23.1	4	85				50 - 150	146235
	150-400	700	27.3	4	115				150 - 400	146242



## CHE-3F(B) 3-core outdoor cable termination

for all 3-core polymeric cables

Hybrid cable terminations CHE-3F(B) are suitable for all 3-core polymeric-insulated cables (PVC, PE, XLPE, EPR) with different types of semi-conductive layers (graphite-coated, removable or strippable) and screen design (copper wire or tape). Suitable for compression or screw cable lugs.

### Characteristics

- Flexible silicone stress control elements ensure reliable stress control under all operating conditions
- Combination of slip-on and heat shrinkable components
- Wide cross-section range
- Quick, safe and easy assembly
- Ready for immediate operation

### Application/Suitability

- Outdoor

### Voltage level

- $U_0/U_m$  6/10 (12) kV - 19/33 (36) kV

### Note

- 12 kV cable terminations must be used for 7.2 kV cables. (Check minimum diameter over conductor insulation.)

### Test standards

- CENELEC HD 629.1 (DIN VDE 0278, part 629-1)

### Storage conditions/Shelf life

- Unlimited shelf life



### Dimensions

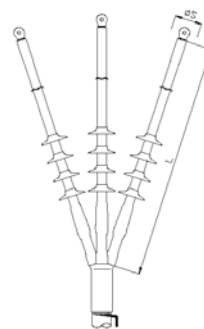

Ø S = Diameter of cable shed

### Scope of delivery

Spreader cap (tracking resistant), heat shrinkable tube (tracking resistant), silicone stress control elements, silicone sheds, pressure spring, sealing tape, assembly material, assembly instructions



Optional accessory: Cable lugs (see Connecting technology)  
EGA earthing kit for cables with tape screen (see Connecting technology)

Note: Other cable terminations available on request.

Type	L mm	min. Ø over core insulation after removal of the outer conductive layer mm	Number of sheds per phase	Ø S mm	12 kV	17.5 kV	24 kV	36 kV	Art.-No.	
					Nominal cross section mm <sup>2</sup>					
<b><math>U_0/U_m</math> 6/10 (12) kV - 6.35/11 (12) kV</b>										
<b>CHE-3F(B) 12kV</b>	10-25	700	9.9	1	80	10 - 25			184805	
	25-95	700	12.6	1	85	25 - 95			184806	
	95-240	700	17.3	1	85	95 - 240			184807	
	150-400	700	19.9	1	85	150 - 400			184808	
<b><math>U_0/U_m</math> 8.7/15 (17.5) kV</b>										
<b>CHE-3F(B) 17kV</b>	25-50	700	12.6	2	85		25 - 50		182735	
	70-240	700	17.3	2	85		70 - 240		182736	
	150-300	700	20.9	2	85		150 - 300		182737	
	185-400	700	23.1	2	85		185 - 400		182738	
<b><math>U_0/U_m</math> 12/20 (24) kV - 12.7/22 (24) kV</b>										
<b>CHE-3F(B) 24kV</b>	10-35	850	12.6	3	85			10 - 35	184472	
	25-95	850	17.3	3	85			25 - 95	184809	
	70-240	850	20.9	3	85			70 - 240	184811	
	120-400	850	23.1	3	85			120 - 400	184812	
<b><math>U_0/U_m</math> 18/30 (36) kV - 19/33 (36) kV</b>										
<b>CHE-3F(B) 36kV</b>	35-70	850	22.5	4	85				35 - 70	184813
	50-150	850	23.1	4	85				50 - 150	184815
	150-400	850	27.3	4	115				150 - 400	184816

# MEDIUM VOLTAGE

## Cable sets for mass-impregnated paper cables

	Transition joints . . . . .	173
	Straight-through joints . . . . .	182
	Cable terminations . . . . .	185

## Overview: Cellpack Cable sets selection table

Products	Belted cables			H-Type cables			3 lead sheath cables		
	Transition joints	Straight-through joints	Cable terminations	Transition joints	Straight-through joints	Cable terminations	Transition joints	Straight-through joints	Cable terminations
CHMPRSV3-1	●	-	-	●	-	-	-	-	-
CHMPR3-1	●	-	-	●	-	-	-	-	-
CHMPR3	●	-	-	●	-	-	-	-	-
CHMP(H)SV3-1	-	-	-	●	-	-	-	-	-
CHMP(H)3-1	-	-	-	●	-	-	-	-	-
CHMP(H)3	-	-	-	●	-	-	-	-	-
CHMP(3Pb)SV3-1	-	-	-	-	-	-	●	-	-
CHMP(3Pb)3-1	-	-	-	-	-	-	●	-	-
CHMP(3Pb)3	-	-	-	-	-	-	●	-	-
CHMPPR3	-	●	-	-	●	-	-	-	-
CHMPP(H)3	-	-	-	-	●	-	-	-	-
CHMPP(3Pb)3	-	-	-	-	-	-	-	●	-
CHEP-3I	-	-	●	-	-	-	-	-	-
CHEP-3F	-	-	●	-	-	-	-	-	-
CHEP(H)-3I	-	-	-	-	-	●	-	-	-
CHEP(H)-3F	-	-	-	-	-	●	-	-	-
CHEP(3Pb)-3I	-	-	-	-	-	-	-	-	●
CHEP(3Pb)-3F	-	-	-	-	-	-	-	-	●

- suitable
- non suitable

MEDIUM VOLTAGE  
Cable sets for mass-impregnated paper cables

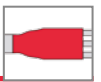

## CHMPRSV3-1 Transition joint

with screw connectors, from belted cables/H-Type cables to 1-core polymeric cables

Hybrid transition joints CHMPRSV3-1 for transition to three 1-core polymeric-insulated cables, are suitable for belted cables and H-Type cables up to 17.5 kV. With screw connectors.

### Characteristics

- Reliable stress control due to flexible silicone stress control elements
- Wide cross-section range
- Quick, safe and easy assembly
- Ready for immediate operation
- Suitable for a wide range of applications due to innovative integrated screw connector

### Application/Suitability

- Indoor
- Outdoor
- Underground
- Water
- Installation ducts
- Ductwork

### Voltage level

- $U_0/U_m$  6/10 (12) kV - 8.7/15 (17.5) kV

### Test standards

- CENELEC HD 629.2 (DIN VDE 0278, part 629-2)

### Storage conditions/Shelf life

- Unlimited shelf life



### Dimensions

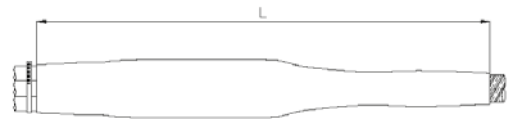

### Scope of delivery

Spreader cap, thick wall heat shrinkable outer tube with hot melt adhesive, oil barrier tubing, heat shrinkable tubes, silicone stress control elements, earthing wire, copper braid tape, pressure spring, screw connector for copper-wire screen, assembly material, sealing tape, field control filling tape (blue), fire protection wrapping, innovative screw connectors with conductive cover, assembly instructions

Type	L mm	min. Ø over core insulation after removal of the outer conductive layer mm	Nominal cross section mm <sup>2</sup>		Art.-No.	
			12 kV	17.5 kV		
$U_0/U_m$ 6/10 (12) kV - 8.7/15 (17.5) kV						
CHMPRSV3-1 17kV	35-95	1200	12.6	50 - 95	35 - 95	264988
	70-150	1200	17.3	95 - 150	70 - 150	265205
	95-240	1200	17.3	95 - 240	95 - 240	264769
	240-400	1200	23.1	240 - 400	240 - 400	265501



# CHMPR3-1 Transition joint

from belted cables/H-Type cables to 1-core polymeric cables

Hybrid transition joints CHMPR3-1 for transition to three 1-core polymeric-insulated cables, are suitable for belted cables and H-Type cables up to 17.5 kV. The scope of application can be reduced by an appropriate padding set for the mass-impregnated paper cable. Suitable for compression connectors.

### Characteristics

- Reliable stress control due to flexible silicone stress control elements
- Wide cross-section range
- Quick, safe and easy assembly
- Ready for immediate operation

### Application/Suitability

- Indoor
- Outdoor
- Underground
- Water
- Installation ducts
- Ductwork

### Voltage level

- $U_0/U_m$  6/10 (12) kV - 8.7/15 (17.5) kV

### Test standards

- CENELEC HD 629.2 (DIN VDE 0278, part 629-2)

### Storage conditions/Shelf life

- Unlimited shelf life

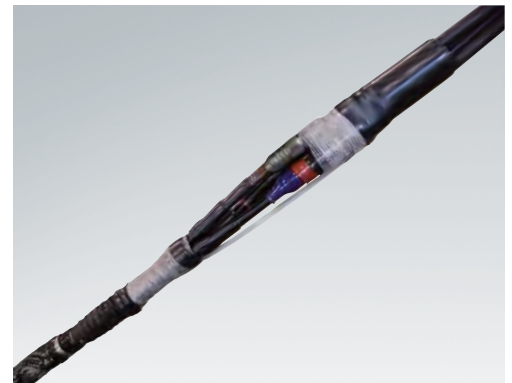

Dimensions

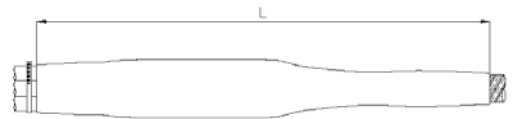

### Scope of delivery

Spreader cap, thick wall heat shrinkable outer tube with hot melt adhesive, oil barrier tubing, heat shrinkable tubes, silicone stress control elements, earthing wire, copper braid tape, pressure spring, assembly material, sealing tape, field control filling tape (blue), fire protection wrapping, assembly instructions

Optional accessory: Compression connectors (see Connecting technology)

Note: Other transition joints available on request.

Type	L mm	min. Ø over core insulation after re- moval of the outer conductive layer mm	12 kV			17.5 kV			Art.-No.	
			Nominal cross section mm <sup>2</sup>	max. Connector- Ø mm	max. Connector length mm	Nominal cross section mm <sup>2</sup>	max. Connector- Ø mm	max. Connector length mm		
$U_0/U_m$ 6/10 (12) kV - 8.7/15 (17.5) kV										
CHMPR3-1 17kV	35-50	1100	12.6	50 - 95	25	145	35 - 50	20	110	197603
	70-240	1100	17.3	95 - 300	34	145	70 - 240	34	145	197604 <sup>1)</sup>
	240-400	1100	23.1	300 - 400	42	170	240 - 400	42	170	197606

<sup>1)</sup> Padding kit PS(G+H) 17/1 (Art.-No.197690) to be used for 25 - 50 mm<sup>2</sup> (17.5 kV) and (25) 35 - 70 mm<sup>2</sup> (12 kV).

MEDIUM VOLTAGE  
Cable sets for mass-impregnated paper cables

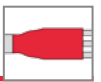

## CHMPR3 Transition joint

from belted cables/H-Type cables to 3-core polymeric cables

Hybrid transition joints CHMPR3 for transition to one 3-core polymeric-insulated cable, are suitable for belted cables and H-Type cables up to 17.5 kV. The scope of application can be reduced by an appropriate padding set for the mass-impregnated paper cable. Suitable for compression connectors.

### Characteristics

- Reliable stress control due to flexible silicone stress control elements
- Wide cross-section range
- Quick, safe and easy assembly
- Ready for immediate operation

### Application/Suitability

- Indoor
- Outdoor
- Underground
- Water
- Installation ducts
- Ductwork

### Voltage level

- $U_0/U_m$  6/10 (12) kV - 8.7/15 (17.5) kV

### Test standards

- CENELEC HD 629.2 (DIN VDE 0278, part 629-2)

### Storage conditions/Shelf life

- Unlimited shelf life

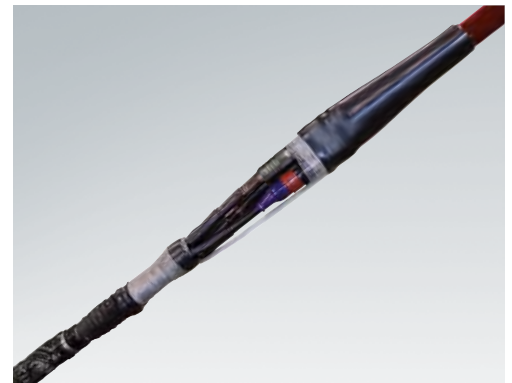

### Dimensions

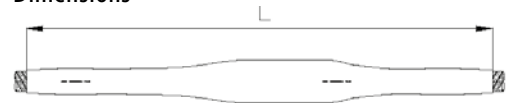

### Scope of delivery

Spreader cap, thick wall heat shrinkable outer tube with hot melt adhesive, oil barrier tubing, heat shrinkable tubes, silicone stress control elements, earthing wire, copper braid tape, pressure spring, assembly material, sealing tape, field control filling tape (blue), fire protection wrapping, assembly instructions

Optional accessory: Compression connectors (see Connecting technology)

Note: Other transition joints available on request.

Type	L mm	min. Ø over core insulation after re- moval of the outer conductive layer mm	12 kV			17.5 kV			Art.-No.	
			Nominal cross section mm <sup>2</sup>	max. Connector- Ø mm	max. Connector length mm	Nominal cross section mm <sup>2</sup>	max. Connector- Ø mm	max. Connector length mm		
$U_0/U_m$ 6/10 (12) kV - 8.7/15 (17.5) kV										
CHMPR3 17kV	35-50	1400	12.6	50 - 95	25	145	35 - 50	20	110	197618
	70-240	1400	17.3	95 - 300	34	145	70 - 240	34	145	197619 <sup>1)</sup>
	240-400	1400	23.1	300 - 400	42	170	240 - 400	42	170	197620

<sup>1)</sup> Padding kit PS(G+H) 17/1 (Art.-No.197690) to be used for 25 - 50 mm<sup>2</sup> (17.5 kV) and (25) 35 - 70 mm<sup>2</sup> (12 kV).



# CHMP(H)SV3-1 NEW Transition joint

with screw connectors, from H-Type cables to polymeric 1-core cables

Hybrid transition joints CHMP(H)SV3-1 for transition to three 1-core polymeric-insulated cables, are suitable for H-Type cables for 24 kV. With screw connectors.

### Characteristics

- Reliable stress control due to flexible silicone stress control elements
- Wide cross-section range
- Quick, safe and easy assembly
- Ready for immediate operation

### Application/Suitability

- Indoor
- Outdoor
- Underground
- Water
- Installation ducts
- Ductwork

### Voltage level

- $U_0/U_m$  12/20 (24) kV - 12.7/22 (24) kV

### Test standards

- CENELEC HD 629.2 (DIN VDE 0278, part 629-2)

### Storage conditions/Shelf life

- Unlimited shelf life

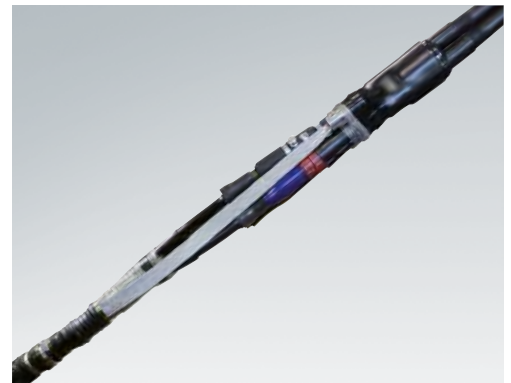

Dimensions

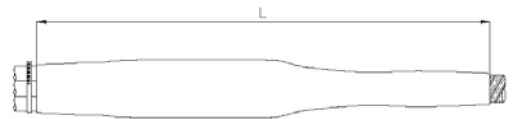

### Scope of delivery

Spreader cap, thick wall heat shrinkable outer tube with hot melt adhesive, oil barrier tubing, heat shrinkable tubes, silicone stress control elements, earthing wire, copper braid tape, pressure spring, assembly material, sealing tape, field control filling tape (blue), fire protection wrapping, innovative screw connectors with conductive cover, assembly instructions

Type	L mm	min. Ø over core insulation after removal of the outer conductive layer mm	24 kV	
			Nominal cross section mm <sup>2</sup>	Art.-No.
$U_0/U_m$ 12/20 (24) kV - 12.7/22 (24) kV				
CHMP(H)SV3-1 24kV	35-95	1100	17.3	336538
	70-150	1100	19.9	336550
	95-240	1100	19.9	336551



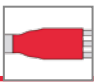

## CHMP(H)3-1 Transition joint

from H-Type cables to polymeric 1-core cables

Hybrid transition joints CHMP(H)3-1 for transition to three 1-core polymeric-insulated cables, are suitable for H-Type cables from 24 to 36 kV. The scope of application can be reduced by an appropriate padding set for the mass-impregnated paper cable. Suitable for compression connectors.

### Characteristics

- Reliable stress control due to flexible silicone stress control elements
- Wide cross-section range
- Quick, safe and easy assembly
- Ready for immediate operation

### Application/Suitability

- Indoor
- Outdoor
- Underground
- Water
- Installation ducts
- Ductwork

### Voltage level

- $U_0/U_m$  (U<sub>m</sub>) 12/20 (24) kV - 19/33 (36) kV

### Test standards

- CENELEC HD 629.2 (DIN VDE 0278, part 629-2)

### Storage conditions/Shelf life

- Unlimited shelf life

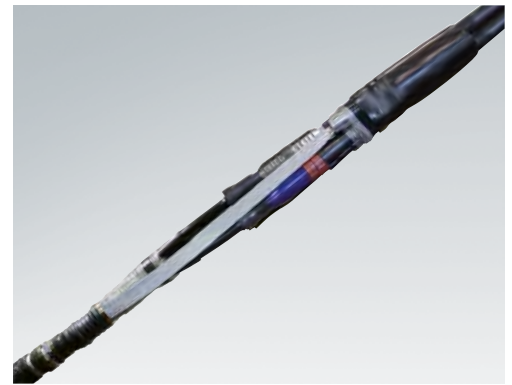

### Dimensions

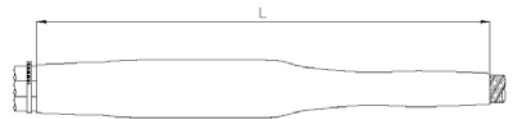

### Scope of delivery

Spreader cap, thick wall heat shrinkable outer tube with hot melt adhesive, oil barrier tubing, heat shrinkable tubes, silicone stress control elements, earthing wire, copper braid tape, pressure spring, assembly material, sealing tape, field control filling tape (blue), fire protection wrapping, assembly instructions

Optional accessory: Compression connectors (see Connecting technology)

Note: Other transition joints available on request.

Type	L mm	min. Ø over core insulation after re- moval of the outer conductive layer mm	max. Connector- Ø mm	max. Connector length mm	24 kV	36 kV	Art.-No.
					Nominal cross section mm <sup>2</sup>		
<b><math>U_0/U_m</math> (U<sub>m</sub>) 12/20 (24) kV - 12.7/22 (24) kV</b>							
CHMP(H)3-1 36kV	35-70	1200	17.3	20	110	35 - 70	197608
	95-240	1200	19.9	34	145	95 - 240	197609 <sup>1)</sup>
	185-300	1200	23.1	42	145	185 - 300	197610
<b><math>U_0/U_m</math> (U<sub>m</sub>) 18/30 (36) kV - 19/33 (36) kV</b>							
CHMP(H)3-1 36kV	35-50	1200	19.9	20	110		197614
	70-150	1200	23.1	28	145		197616
	150-300	1200	27.3	36	145		197617

<sup>1)</sup> Padding kit PS(H) 24/1 (Art.-No.197692) to be used for 35 - 70 mm<sup>2</sup> (24 kV).



# CHMP(H)3 Transition joint

from H-Type cables to 3-core polymeric cables

Hybrid transition joints CHMP(H)3 for transition to one 3-core polymeric-insulated cable, are suitable for H-Type cables from 24 to 36 kV. The scope of application can be reduced by an appropriate padding set for the mass-impregnated paper cable. Suitable for compression connectors.

### Characteristics

- Reliable stress control due to flexible silicone stress control elements
- Wide cross-section range
- Quick, safe and easy assembly
- Ready for immediate operation

### Application/Suitability

- Indoor
- Outdoor
- Underground
- Water
- Installation ducts
- Ductwork

### Voltage level

- $U_0/U_m$  (12/20 (24) kV - 19/33 (36) kV)

### Test standards

- CENELEC HD 629.2 (DIN VDE 0278, part 629-2)

### Storage conditions/Shelf life

- Unlimited shelf life



Dimensions

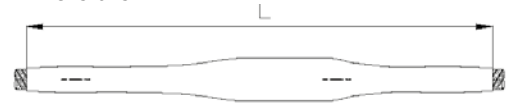

### Scope of delivery

Spreader cap, thick wall heat shrinkable outer tube with hot melt adhesive, oil barrier tubing, heat shrinkable tubes, silicone stress control elements, earthing wire, copper braid tape, pressure spring, assembly material, sealing tape, field control filling tape (blue), fire protection wrapping, assembly instructions

Optional accessory: Compression connectors (see Connecting technology)

Note: Other transition joints available on request.

Type	L mm	min. Ø over core insulation after re- moval of the outer conductive layer mm	max. Connector- Ø mm	max. Connector length mm	24 kV	36 kV	Art.-No.
					Nominal cross section mm <sup>2</sup>		
<b><math>U_0/U_m</math> 12/20 (24) kV - 12.7/22 (24) kV</b>							
CHMP(H)3 24kV	16-35	1400	12.6	15	100	16 - 35	197621
	35-70	1400	17.3	20	110	35 - 70	197622
	95-240	1400	19.9	34	145	95 - 240	197623 <sup>1)</sup>
	185-300	1400	23.1	42	145	185 - 300	197624
<b><math>U_0/U_m</math> 18/30 (36) kV - 19/33 (36) kV</b>							
CHMP(H)3 36kV	35-50	1400	19.9	20	110		35 - 50 197625
	70-150	1400	23.1	28	145		70 - 150 197626
	150-300	1400	27.3	36	145		150 - 300 197627

<sup>1)</sup> Padding kit PS(H) 24/1 (Art.-No.197692) to be used for 35 - 70 mm<sup>2</sup> (24 kV).

MEDIUM VOLTAGE  
Cable sets for mass-impregnated paper cables

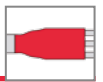

## CHMP(3Pb)SV3-1 NEW

### Transition joint

with screw connectors, for 3 lead sheath cables to 1-core polymeric cables

Hybrid transition joints CHMP(3Pb)SV3-1 for transition to three 1-core polymeric-insulated cables are suitable for all 3 lead sheath cables for 24 kV. With screw connectors.

#### Characteristics

- Reliable stress control due to flexible silicone stress control elements
- Wide cross-section range
- Quick, safe and easy assembly
- Ready for immediate operation

#### Application/Suitability

- Indoor
- Outdoor
- Underground
- Water
- Installation ducts
- Ductwork

#### Voltage level

- $U_0/U_m$  12/20 (24) kV - 12.7/22 (24) kV

#### Test standards

- CENELEC HD 629.2 (DIN VDE 0278, part 629-2)

#### Storage conditions/Shelf life

- Unlimited shelf life



#### Dimensions

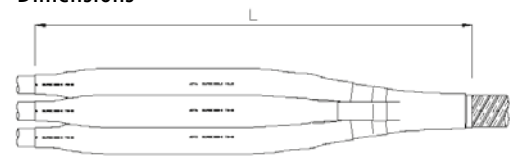

#### Scope of delivery

Spreader cap, thick wall heat shrinkable outer tube with hot melt adhesive, oil barrier tubing, heat shrinkable tubes, silicone stress control elements, earthing wire, copper braid tape, pressure spring, innovative screw connectors with conductive cover, assembly material, sealing tape, field control filling tape (blue), fire protection wrapping, assembly instructions

Type	L mm	min. Ø over core insulation after removal of the outer conductive layer mm	24 kV	
			Nominal cross section mm <sup>2</sup>	Art.-No.
$U_0/U_m$ 12/20 (24) kV - 12.7/22 (24) kV				
CHMP(3Pb)SV3-1 24kV	35-95	1000	17.3	35 - 95
	50-150	1000	17.3	50 - 150
	95-240	1000	19.9	95 - 240
	240-400	1000	27.3	240 - 400



# CHMP(3Pb)3-1 Transition joint

for 3 lead sheath cables to 1-core polymeric cables

Hybrid transition joints CHMP(3Pb)3-1 for transition to three 1-core polymeric-insulated cables are suitable for all 3 lead sheath cables up to 36 kV. The scope of application can be reduced by an appropriate padding set for the mass-impregnated paper cable. Suitable for compression connectors.

### Characteristics

- Reliable stress control due to flexible silicone stress control elements
- Wide cross-section range
- Quick, safe and easy assembly
- Ready for immediate operation

### Application/Suitability

- Indoor
- Outdoor
- Underground
- Water
- Installation ducts
- Ductwork

### Voltage level

- $U_0/U_m$  6/10 (12) kV - 19/33 (36) kV

### Test standards

- CENELEC HD 629.2 (DIN VDE 0278, part 629-2)

### Storage conditions/Shelf life

- Unlimited shelf life



Dimensions

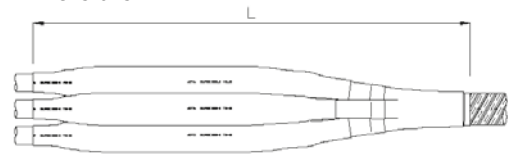

### Scope of delivery

Spreader cap, thick wall heat shrinkable outer tube with hot melt adhesive, oil barrier tubing, heat shrinkable tubes, silicone stress control elements, earthing wire, copper braid tape, pressure spring, assembly material, sealing tape, field control filling tape (blue), fire protection wrapping, assembly instructions

Optional accessory: Compression connectors (see Connecting technology)

Type	L mm	min. Ø over core insulation after removal of the outer conductive layer mm	12 kV			17.5 kV			Art.-No.	
			Nominal cross section mm <sup>2</sup>	max. Connector-Ø mm	max. Connector length mm	Nominal cross section mm <sup>2</sup>	max. Connector-Ø mm	max. Connector length mm		
$U_0/U_m$ 6/10 (12) kV - 8.7/15 (17.5) kV										
CHMP(3Pb)3-1 17kV	25-50	1200	12.6	50 - 95	25	110	25 - 50	20	110	197628
	70-150	1200	17.3	95 - 185	32	140	70 - 150	25	140	198782
	120-240	1200	19.9	150 - 300	36	150	120 - 240	34	150	197629
	240-400	1200	23.1	300 - 400	40	170	240 - 300	40	150	197630

Type	L mm	min. Ø over core insulation after removal of the outer conductive layer mm	max. Connector-Ø mm	max. Connector length mm	24 kV		36 kV		Art.-No.
					Nominal cross section mm <sup>2</sup>				
$U_0/U_m$ 12/20 (24) kV - 12.7/22 (24) kV									
CHMP(3Pb)3-1 24kV	16-25	1200	12.6	20	100	16 - 25			197631
	35-95	1200	17.3	25	110	35 - 95			197632
	95-240	1200	19.9	34	150	95 - 240			197633 <sup>1)</sup>
	185-300	1200	23.1	40	150	185 - 300			197634
$U_0/U_m$ 18/30 (36) kV - 19/33 (36) kV									
CHMP(3Pb)3-1 36kV	35-50	1200	19.9	20	110		35 - 50		197635
	70-150	1200	23.1	25	150		70 - 150		197636 <sup>2)</sup>
	150-300	1200	27.3	38	160		150 - 300		197637 <sup>3)</sup>

<sup>1)</sup> Padding kit PS(3Pb+Pb), (Art.-No.197699) to be used for 35 - 70 mm<sup>2</sup> (24 kV).

<sup>2)</sup> Padding kit PS(3Pb+Pb), (Art.-No.197701) to be used for 35 - 50 mm<sup>2</sup> (36 kV).

<sup>3)</sup> Padding kit PS(3Pb+Pb), (Art.-No.197702) to be used for 70 - 150 mm<sup>2</sup> (36 kV).

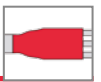

## CHMP(3Pb)3 Transition joint

for 3 lead sheath cables to 3-core polymeric cables

Hybrid transition joints CHMP(3Pb)3 for transition to one 3-core polymeric-insulated cables are suitable for all 3 lead sheath cables up to 36 kV. The scope of application can be reduced by an appropriate padding set for the mass-impregnated paper cable. Suitable for compression connectors.

### Characteristics

- Reliable stress control due to flexible silicone stress control elements
- Wide cross-section range
- Quick, safe and easy assembly
- Ready for immediate operation

### Application/Suitability

- Indoor
- Outdoor
- Underground
- Water
- Installation ducts
- Ductwork

### Voltage level

- $U_0/U_m$  (U<sub>m</sub>) 6/10 (12) kV - 19/33 (36) kV

### Test standards

- CENELEC HD 629.2 (DIN VDE 0278, part 629-2)

### Storage conditions/Shelf life

- Unlimited shelf life



Dimensions

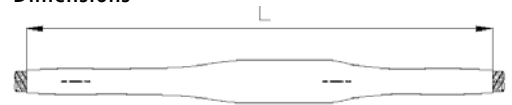

### Scope of delivery

Spreader cap, thick wall heat shrinkable outer tube with hot melt adhesive, oil barrier tubing, heat shrinkable tubes, silicone stress control elements, earthing wire, copper braid tape, pressure spring, assembly material, sealing tape, field control filling tape (blue), fire protection wrapping, assembly instructions

Optional accessory: Compression connectors (see Connecting technology)

Type	L mm	min. Ø over core insulation after re- moval of the outer conductive layer mm	12 kV			17.5 kV			Art.-No.	
			Nominal cross section mm <sup>2</sup>	max. Connector- Ø mm	max. Connector length mm	Nominal cross section mm <sup>2</sup>	max. Connector- Ø mm	max. Connector length mm		
$U_0/U_m$ (U <sub>m</sub> ) 6/10 (12) kV - 8.7/15 (17.5) kV										
CHMP(3Pb)3 17kV	25-50	1400	12.6	50 - 95	25	110	25 - 50	20	110	197638
	70-150	1400	17.3	95 - 185	32	140	70 - 150	25	140	198783
	120-240	1400	19.9	150 - 300	36	150	120 - 240	34	150	197639
	240-400	1400	23.1	300 - 400	40	170	240 - 300	40	150	197640

Type	L mm	min. Ø over core insulation after re- moval of the outer conductive layer mm	max. Connector- Ø mm	max. Connector length mm	24 kV		36 kV		Art.-No.
					Nominal cross section mm <sup>2</sup>				
$U_0/U_m$ (U <sub>m</sub> ) 12/20 (24) kV - 12.7/22 (24) kV									
CHMP(3Pb)3 24kV	16-25	1400	12.6	20	100	16 - 25			197641
	35-95	1400	17.3	25	110	35 - 95			197642
	95-240	1400	19.9	34	150	95 - 240			197643 <sup>1)</sup>
	185-300	1400	23.1	40	150	185 - 300			197644
$U_0/U_m$ (U <sub>m</sub> ) 18/30 (36) kV - 19/33 (36) kV									
CHMP(3Pb)3 36kV	35-50	1400	19.9	20	110		35 - 50		197645
	70-150	1400	23.1	25	150		70 - 150		197646 <sup>2)</sup>
	150-300	1400	27.3	38	160		150 - 300		197647 <sup>3)</sup>

<sup>1)</sup> Padding kit PS(3Pb+Pb), (Art.-No.197699) to be used for 35 - 70 mm<sup>2</sup> (24 kV).

<sup>2)</sup> Padding kit PS(3Pb+Pb), (Art.-No.197701) to be used for 35 - 50 mm<sup>2</sup> (36 kV).

<sup>3)</sup> Padding kit PS(3Pb+Pb), (Art.-No.197702) to be used for 70 - 150 mm<sup>2</sup> (36 kV).



## CHMPPR3

### Straight-through joint

for belted cables/H-Type cables up to 17.5 kV (MIND)

Hybrid straight-through joints CHMPPR3 are suitable for belted cables and H-Type cables up to 17.5 kV. Suitable for compression connectors.

#### Characteristics

- Wide cross-section range
- Quick, safe and easy assembly
- Ready for immediate operation

#### Application/Suitability

- Indoor
- Outdoor
- Underground
- Water
- Installation ducts
- Ductwork

#### Voltage level

- $U_0/U_m$  6/10 (12) kV - 8.7/15 (17.5) kV

#### Test standards

- CENELEC HD 629.2 (DIN VDE 0278, part 629-2)

#### Storage conditions/Shelf life

- Unlimited shelf life

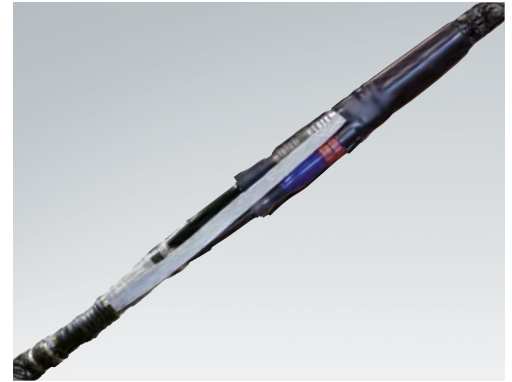

Dimensions

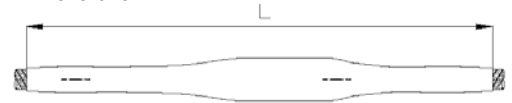

#### Scope of delivery

Spreader cap, thick wall heat shrinkable outer tube with hot melt adhesive, oil barrier tubing, heat shrinkable tubes, earthing wire, copper braid tape, pressure spring, assembly material, sealing tape, field control filling tape (blue), fire protection wrapping, assembly instructions

Optional accessory: Compression connectors (see Connecting technology)

Type	L mm	12 kV			17.5 kV			Art.-No.	
		Nominal cross section mm <sup>2</sup>	max. Connector-Ø mm	max. Connector length mm	Nominal cross section mm <sup>2</sup>	max. Connector-Ø mm	max. Connector length mm		
$U_0/U_m$ 6/10 (12) kV - 8.7/15 (17.5) kV									
CHMPPR3 17kV	35-50	1400	50 - 95	25	145	35 - 50	20	110	197658
	70-240	1400	95 - 300	34	145	70 - 240	34	145	197659
	240-400	1400	300 - 400	42	170	240 - 400	42	170	197660



## CHMPP(H)3 Straight-through joint

for H-Type cables from 24 to 36 kV

Hybrid straight-through joints CHMPP(H)3 are suitable for H-Type cables from 24 to 36 kV. The scope of application can be reduced by an appropriate padding set for the mass-impregnated paper cable. Suitable for compression connectors.

### Characteristics

- Wide cross-section range
- Quick, safe and easy assembly
- Ready for immediate operation

### Application/Suitability

- Indoor
- Outdoor
- Underground
- Water
- Installation ducts
- Ductwork

### Voltage level

- $U_0/U_m$  12/20 (24) kV - 19/33 (36) kV

### Test standards

- CENELEC HD 629.2 (DIN VDE 0278, part 629-2)

### Storage conditions/Shelf life

- Unlimited shelf life

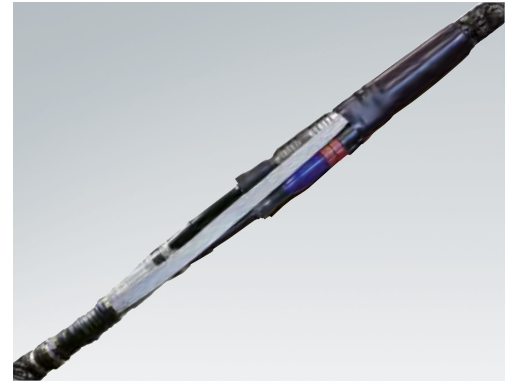

Dimensions

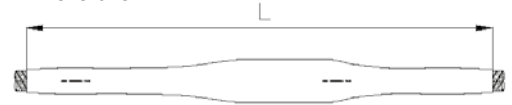

### Scope of delivery

Spreader cap, thick wall heat shrinkable outer tube with hot melt adhesive, oil barrier tubing, heat shrinkable tubes, silicone stress control elements, earthing wire, copper braid tape, pressure spring, assembly material, sealing tape, spacers, field control filling tape (blue), fire protection wrapping, assembly instructions

Optional accessory: Compression connectors (see Connecting technology)

Type	L mm	min. Ø over core insulation mm	max. Connector- Ø mm	max. Connector length mm	24 kV	36 kV	Art.-No.
					Nominal cross section mm <sup>2</sup>		
<b><math>U_0/U_m</math> 12/20 (24) kV - 12.7/22 (24) kV</b>							
CHMPP(H)3 24kV	16-35	1400	16.5	15	100	16 - 35	197661
	35-70	1400	17.4	20	110	35 - 70	197662
	95-240	1400	21.6	34	145	95 - 240	197663 <sup>1)</sup>
	185-300	1400	25.8	42	145	185 - 300	197664
<b><math>U_0/U_m</math> 18/30 (36) kV - 19/33 (36) kV</b>							
CHMPP(H)3 36kV	35-50	1400	21.4	20	100	35 - 50	197665
	70-150	1400	24.0	28	145	70 - 150	197666
	150-300	1400	28.2	36	145	150 - 300	197667

<sup>1)</sup> Padding kit PS(H) 24/1 (Art.-No.197692) to be used for 35 - 70 mm<sup>2</sup> (24 kV).



# CHMPP(3Pb)3 Straight-through joint

for 3 lead sheath cables up to 36 kV

Hybrid straight-through joints CHMPP(3Pb)3 are suitable for all 3 lead sheath cables up to 36 kV. Suitable for compression connectors.

### Characteristics

- Wide cross-section range
- Quick, safe and easy assembly
- Ready for immediate operation

### Application/Suitability

- Indoor
- Outdoor
- Underground
- Water
- Installation ducts
- Ductwork

### Voltage level

- $U_0/U_m$  (U<sub>m</sub>) 6/10 (12) kV - 19/33 (36) kV

### Test standards

- CENELEC HD 629.2 (DIN VDE 0278, part 629-2)

### Storage conditions/Shelf life

- Unlimited shelf life



Dimensions

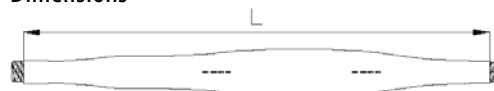

### Scope of delivery

Spreader cap, thick wall heat shrinkable outer tube with hot melt adhesive, oil barrier tubing, heat shrinkable tubes, silicone stress control elements, earthing wire, copper braid tape, pressure spring, assembly material, sealing tape, field control filling tape (blue), fire protection wrapping, assembly instructions

Optional accessory: Compression connectors (see Connecting technology)

Type	L mm	min. Ø over core insulation after removal of the outer conductive layer mm	12 kV			17.5 kV			Art.-No.	
			Nominal cross section mm <sup>2</sup>	max. Connector-Ø mm	max. Connector length mm	Nominal cross section mm <sup>2</sup>	max. Connector-Ø mm	max. Connector length mm		
$U_0/U_m$ (U <sub>m</sub> ) 6/10 (12) kV - 8.7/15 (17.5) kV										
CHMPP(3Pb)3 17kV	25-50	1400	14.1	50 - 95	25	110	25 - 50	20	110	197668
	70-150	1400	17.6	95 - 185	32	140	70 - 150	25	140	198784
	120-240	1400	20.5	150 - 300	36	150	120 - 240	34	150	197669
	240-400	1400	25.6	300 - 400	40	170	240 - 300	40	150	197670

Type	L mm	min. Ø over core insulation after removal of the outer conductive layer mm	max. Connector-Ø mm	max. Connector length mm	24 kV		36 kV		Art.-No.
					Nominal cross section mm <sup>2</sup>		Nominal cross section mm <sup>2</sup>		
$U_0/U_m$ (U <sub>m</sub> ) 12/20 (24) kV - 12.7/22 (24) kV									
CHMPP(3Pb)3 24kV	16-25	1400	12.6	100	16 - 25				197671
	35-95	1400	17.3	110	35 - 95				197672
	95-240	1400	19.9	150	95 - 240				197673
	185-300	1400	23.1	150	185 - 300				197674
$U_0/U_m$ (U <sub>m</sub> ) 18/30 (36) kV - 19/33 (36) kV									
CHMPP(3Pb)3 36kV	35-50	1400	21.4	110			35 - 50		197675
	70-150	1400	24.0	150			70 - 150		197676
	150-300	1400	28.2	160			150 - 300		197677

MEDIUM VOLTAGE  
Cable sets for mass-impregnated paper cables





## CHEP-3I

### Indoor cable termination

for belted cables up to 17.5 kV (MIND)

Hybrid cable terminations CHEP-3I are suitable for belted cables up to 17.5 kV (for MIND cables only). Suitable for compression and screw cable lugs.

#### Characteristics

- Wide cross-section range
- Quick, safe and easy assembly
- Ready for immediate operation

#### Application/Suitability

- Indoor

#### Voltage level

- $U_0/U_m$  6/10 (12) kV - 8.7/15 (17.5) kV

#### Test standards

- CENELEC HD 629.2  
(DIN VDE 0278, part 629-2)

#### Storage conditions/Shelf life

- Unlimited shelf life



#### Dimensions

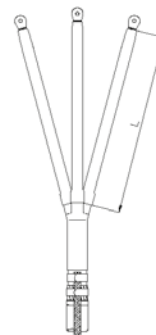

#### Scope of delivery

Spreader cap (tracking resistant), heat shrinkable tube (tracking resistant), earthing set, sealing tape, assembly material, assembly instructions

Optional accessory: Cable lugs (see Connecting technology)

Note: For cables with draining compound, please contact us.

Type	L mm	min. Ø over core insulation mm	Nominal cross section mm <sup>2</sup>		Art.-No.
			12 kV	17.5 kV	
$U_0/U_m$ 6/10 (12) kV - 8.7/15 (17.5) kV					
CHEP-3I 17kV	16-50	500	9.9	16 - 50	197515
	25-240	500	13.2	70 - 240	197516
	95-300	500	16.5	120 - 400	197517

**CHEP-3F****Outdoor cable termination**

for belted cables up to 17.5 kV (MIND)

Hybrid cable terminations CHEP-3F are suitable for belted cables up to 17.5 kV (for MIND cables only). Suitable for compression and screw cable lugs.

**Characteristics**

- Wide cross-section range
- Quick, safe and easy assembly
- Ready for immediate operation

**Application/Suitability**

- Outdoor

**Voltage level**

- $U_0/U_m$  6/10 (12) kV - 8.7/15 (17.5) kV

**Test standards**

- CENELEC HD 629.2 (DIN VDE 0278, part 629-2)

**Storage conditions/Shelf life**

- Unlimited shelf life

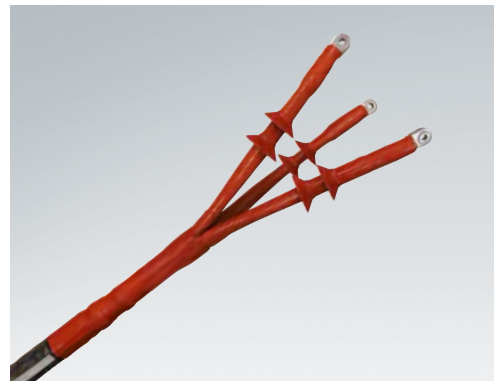
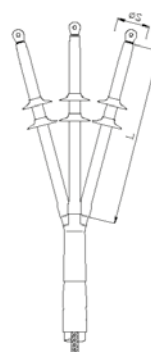
**Dimensions**

Ø S = Diameter of cable shed

**Scope of delivery**

Spreader cap (tracking resistant), heat shrinkable tube (tracking resistant), silicone sheds, earthing set, sealing tape, assembly material, assembly instructions

Optional accessory: Cable lugs (see Connecting technology)

Note: For cables with draining compound, please contact us.

Type	L mm	min. Ø over core insulation mm	Number of sheds per phase	Ø S mm	12 kV	17.5 kV	Art.-No.
					Nominal cross section mm <sup>2</sup>		
$U_0/U_m$ 6/10 (12) kV - 8.7/15 (17.5) kV							
CHEP-3F 17kV	16-50	500	9.9	2	80	16 - 50	197537
	25-240	500	13.2	2	85	70 - 240	197538
	95-300	500	16.5	2	85	95 - 300	197539



## CHEP(H)-3I

### Indoor cable termination

for H-Type cables from 24 to 36 kV

Hybrid cable terminations CHEP(H)-3I are suitable for H-Type cables from 24 to 36 kV (for MIND cables only). Suitable for compression and screw cable lugs.

#### Characteristics

- Wide cross-section range
- Quick, safe and easy assembly
- Ready for immediate operation

#### Application/Suitability

- Indoor

#### Voltage level

- $U_0/U_m$  (24) 12/20 (24) kV - 19/33 (36) kV

#### Test standards

- CENELEC HD 629.2  
(DIN VDE 0278, part 629-2)

#### Storage conditions/Shelf life

- Unlimited shelf life



#### Scope of delivery

Conductive spreader cap, heat shrinkable tube (tracking resistant), conductive heat shrinkable tubes, oil barrier tubing, filling tape, silicone sheds, earthing wire, pressure spring, assembly instructions

Optional accessory: Cable lugs (see Connecting technology)

Note: For cables with draining compound, please contact us.

#### Dimensions

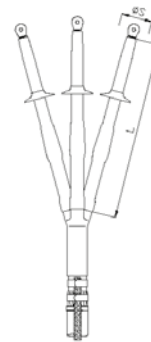

Ø S = Diameter of cable shed

Type	L mm	min. Ø over core insulation mm	Number of sheds per phase	Ø S mm	24 kV		36 kV		Art.-No.
					Nominal cross section mm <sup>2</sup>				
$U_0/U_m$ (24) 12/20 (24) kV - 12.7/22 (24) kV									
CHEP(H)-3I 24kV	16-35	500	12.6	1	80	16 - 35			197531
	50-150	500	17.3	1	85	50 - 150			197532
	70-240	500	19.9	1	85	70 - 240			197533
	120-300	500	23.1	1	85	120 - 300			197534
$U_0/U_m$ (36) 18/30 (36) kV - 19/33 (36) kV									
CHEP(H)-3I 36kV	35-70	650	19.9	2	85		35 - 70		197535
	50-240	650	23.1	2	85		50 - 240		197536



## CHEP(H)-3F Outdoor cable termination

for H-Type cables from 24 to 36 kV

Hybrid cable terminations CHEP(H)-3F are suitable for H-Type cables from 24 to 36 kV (for MIND cables only). Suitable for compression and screw cable lugs.

### Characteristics

- Wide cross-section range
- Quick, safe and easy assembly
- Ready for immediate operation

### Application/Suitability

- Outdoor

### Voltage level

- $U_0/U_m$  12/20 (24) kV - 19/33 (36) kV

### Test standards

- CENELEC HD 629.2 (DIN VDE 0278, part 629-2)

### Storage conditions/Shelf life

- Unlimited shelf life



### Dimensions

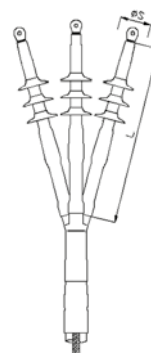

Ø S = Diameter of cable shed

### Scope of delivery

Conductive spreader cap, thick wall heat shrinkable outer tube with hot melt adhesive, heat shrinkable tube (tracking resistant), oil barrier tubing, silicone sheds, earthing wire, pressure spring, sealing tape, oil-barrier field control filling tape (blue), assembly instructions

Optional accessory: Cable lugs (see Connecting technology)

Note: For cables with draining compound, please contact us.

Type	L mm	min. Ø over core insulation mm	Number of sheds per phase	Ø S mm	24 kV	36 kV	Art.-No.
					Nominal cross section mm <sup>2</sup>		
<b><math>U_0/U_m</math> 12/20 (24) kV - 12.7/22 (24) kV</b>							
CHEP(H)-3F 24kV	16-35	850	12.6	3	80	16 - 35	197543
	50-150	850	17.3	3	85	50 - 150	197544
	70-240	850	19.9	3	85	70 - 240	197545
	120-300	850	23.1	3	85	120 - 300	197546
<b><math>U_0/U_m</math> 18/30 (36) kV - 19/33 (36) kV</b>							
CHEP(H)-3F 36kV	35-70	850	19.9	4	85		197547
	50-240	850	23.1	4	85	35 - 70 50 - 240	197548



## CHEP(3Pb)-3I Indoor cable termination

for 3 lead sheath cables from 24 to 36 kV

Hybrid cable terminations CHEP(3Pb)-3I are suitable for 3 lead sheath cables from 24 to 36 kV (for MIND cables only). Suitable for compression and screw cable lugs.

### Characteristics

- Combination of slip-on and heat shrinkable components
- Wide cross-section range
- Quick, safe and easy assembly
- Ready for immediate operation

### Application/Suitability

- Indoor
- Voltage level**
- $U_0/U_m$  12/20 (24) kV - 19/33 (36) kV
- Test standards**
- CENELEC HD 629.2 (DIN VDE 0278, part 629-2)
- Storage conditions/Shelf life**
- Unlimited shelf life



### Scope of delivery

Conductive spreader cap, heat shrinkable tube (tracking resistant), conductive heat shrinkable tubes, oil barrier tubing, silicone sheds, earthing wire, pressure spring, sealing tape, oil-barrier field control filling tape (blue), assembly instructions

Optional accessory: Cable lugs (see Connecting technology)

Note: For cables with draining compound, please contact us.

### Dimensions

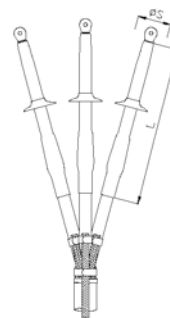

Ø S = Diameter of cable shed

Type	L mm	min. Ø over core insulation mm	Number of sheds per phase	Ø S mm	24 kV	36 kV	Art.-No.
					Nominal cross section mm <sup>2</sup>		
<b><math>U_0/U_m</math> 12/20 (24) kV - 12.7/22 (24) kV</b>							
<b>CHEP(3Pb)-3I 24kV</b>	16-35	450	12.2	1	80	16 - 35	197555
	50-150	450	17.2	1	85	50 - 150	197556
	70-240	450	19.9	1	85	70 - 240	197557
	120-300	450	23.1	1	85	120 - 300	197558
<b><math>U_0/U_m</math> 18/30 (36) kV - 19/33 (36) kV</b>							
<b>CHEP(3Pb)-3I 36kV</b>	35-70	600	19.9	2	85		35 - 70 197559
	95-240	600	23.1	2	85		95 - 240 197560



## CHEP(3Pb)-3F

### Outdoor cable termination

for 3 lead sheath cables from 24 to 36 kV

Hybrid cable terminations CHEP(3Pb)-3F are suitable for 3 lead sheath cables from 24 to 36 kV (for MIND cables only). Suitable for compression and screw cable lugs.

#### Characteristics

- Combination of slip-on and heat shrinkable components
- Wide cross-section range
- Quick, safe and easy assembly
- Ready for immediate operation

#### Application/Suitability

- Outdoor

#### Voltage level

- $U_0/U_m$  12/20 (24) kV - 19/33 (36) kV

#### Test standards

- CENELEC HD 629.2 (DIN VDE 0278, part 629-2)

#### Storage conditions/Shelf life

- Unlimited shelf life

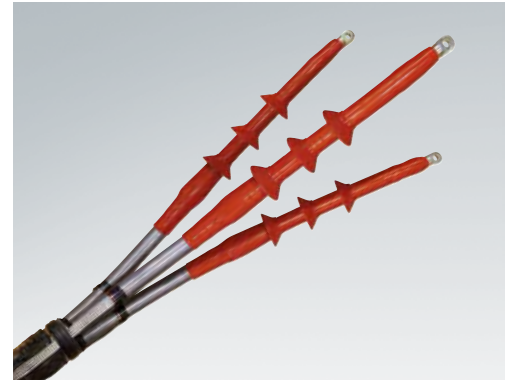

#### Dimensions

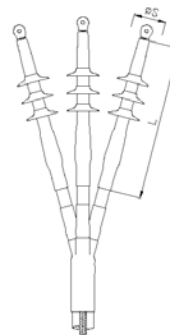

Ø S = Diameter of cable shed

#### Scope of delivery

Weatherproof preader cap, heat shrinkable tube (tracking resistant), oil barrier tubing, silicone sheds, earthing wire, pressure spring, sealing tape, oil-barrier field control filling tape (blue), assembly instructions

Optional accessory: Cable lugs (see Connecting technology)

Note: For cables with draining compound, please contact us.

Type	L mm	min. Ø over core insulation mm	Number of sheds per phase	Ø S mm	24 kV	36 kV	Art.-No.
					Nominal cross section mm <sup>2</sup>		
<b><math>U_0/U_m</math> 12/20 (24) kV - 12.7/22 (24) kV</b>							
CHEP(3Pb)-3F 24kV	16-35	600	12.2	3	80	16 - 35	197567
	50-150	600	17.2	3	85	50 - 150	197568
	70-240	600	19.9	3	85	70 - 240	197569
	120-300	600	23.1	3	85	120 - 300	197570
<b><math>U_0/U_m</math> 18/30 (36) kV - 19/33 (36) kV</b>							
CHEP(3Pb)-3F 36kV	35-70	750	19.9	4	85		197571
	95-240	750	23.1	4	85	35 - 70 95 - 240	197572

# MEDIUM VOLTAGE

## Heat shrinkable components



Heat shrinkable tubes..... 192

**SRBB****Heat shrinkable medium wall tube**

protection for busbar systems and reduction of minimum clearance, halogen-free, shrink ratio 3 : 1

**Characteristics**

- Medium wall
- Stabilized against UV rays
- Halogen-free
- Tracking resistance in compliance with IEC 112
- Non-corrosive
- Resistant to bacteria and fungi
- Free of lead and cadmium
- Silicone free

**Application/Suitability**

- Allows for clearance reduction between busbars in medium voltage substations up to 36 kV
- Corrosion protection

**Material**

- Cross-linked polyolefin

**Test standards**

- Corresponds to IEC 60684-2

**Storage conditions/Shelf life**

- Unlimited shelf life

**Scope of delivery**

Medium wall heat shrinkable tube, on spool or in lengths

Note: A standard spool may include sections which have been tied together. Other lengths available on request.

**Colours**

Red brown

Type	L m	Inner-Ø mm		Recovered wall thickness mm	Art.-No.	
		before shrinking	after shrinking			
<b>Spool   Colour: Red brown</b>						
SRBB	19-6	30	19	6	2.3	201942
	35-11	30	35	11	2.5	201943
	50-18	30	50	18	2.7	201944
	80-26	30	80	26	2.8	201945
	120-40	30	120	40	3	201946
<b>Lengths   Colour: Red brown</b>						
SRBB	19-6	1	19	6	2.3	237858
	35-11	1	35	11	2.5	237859
	50-18	1	50	18	2.7	237860
	80-26	1	80	26	2.8	237861
	120-40	1	120	40	3	237862

→ Continued on the next page





→ Continuation

**SRBB** Heat shrinkable medium wall tube

Technical data	Value	Test standard
<b>Physical properties</b>		
Hardness	39 Shore D	DIN 53 505
Elongation at break	500 %	IEC 60684-2
Tensile strength at break	16 MPa	IEC 60684-2
Longitudinal shrinkage	+5 % up to -10 %	IEC 60684-2
Shrink ratio	3:1	IEC 60684-2
Eccentricity expanded	50 %	IEC 60684-2
recovered	85 %	
<b>Thermal properties</b>		
Operating temperature range	-40 °C up to 120 °C	IEC 60684-2
Shrinkage temperature	> 125 °C	
Burning behaviour	not self-extinguishing	IEC 60684-2 method C
Flexibility at low temperatures	-40 °C	IEC 60684-2
<b>Electrical properties</b>		
Dielectric strength	20 kV/mm	IEC 60684-2
Specific volume resistivity	10 <sup>12</sup> Ω x cm	IEC 60684-2
<b>Chemical properties</b>		
Corrosion	None	IEC 60684-2
Resistance to fungus and decay	Rate 1	IEC 60684-2

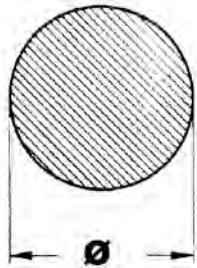
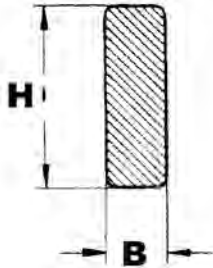
Type	Recommended application range Busbar types: round shaped Diameter [Ø] mm		Recommended application range Busbar types: rectangular shaped Width [B] + Height [H] mm	
	min.	max.	min.	max.
SRBB	19-6	6.5	12	18
	35-11	13	22	36
	50-18	18	31	60
	80-26	28	55	95
	120-40	45	80	150
				

## Minimum allowance between the busbars

Busbar types	Minimum allowance mm			
	12 kV	17.5 kV	24 kV	36 kV
<b>round shaped</b>				
without insulation PH/PH and PH/E	120	160	220	320
with insulation PH/PH	50	65	90	145
with insulation PH/E	60	80	120	200
<b>rectangular shaped</b>				
without insulation PH/PH and PH/E	120	180	220	320
with insulation PH/PH	60	80	110	195
with insulation PH/E	70	100	145	280



## SRAT

### Heat shrinkable thick wall tube

halogen-free, shrink ratio 3 : 1

#### Characteristics

- Thick wall
- Stabilized against UV rays
- Halogen-free
- Non-corrosive
- Infusible
- Highly resistant to electrical breakdown
- Tracking resistance in compliance with IEC 112
- High tensile strength
- Resistant to cold flow (thermally stable)
- Free of lead and cadmium
- Silicone free

#### Application/Suitability

- Insulation tube for conductors in cable terminations of 3.6 to 42 kV

- Corrosion protection

#### Material

- Cross-linked polyolefin

#### Test standards

- Corresponds to IEC 60684-2

#### Storage conditions/Shelf life

- Unlimited shelf life

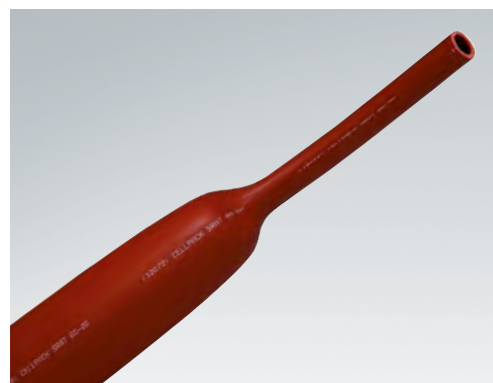

#### Colours



Red brown

#### Scope of delivery

Thick wall heat shrinkable tube, on spool or in lengths

Note: A standard spool may include sections which have been tied together. Other lengths available on request.

Type	L m	Inner-Ø mm		Recovered wall thickness mm	Art.-No.	
		before shrinking	after shrinking			
<b>Spool   Colour: Red brown</b>						
SRAT	19-6	30	19	6	3	144884
	29-9	30	29	9	3	144882
	38-12	30	38	12	3.1	144880
	48-15	30	48	15	3.1	144878
	60-20	30	60	20	3.1	144886
	80-26	30	80	26	3.1	144876
<b>Lengths   Colour: Red brown</b>						
SRAT	19-6	1	19	6	3	144888
	29-9	1	29	9	3	144892
	38-12	1	38	12	3.1	144898
	48-15	1	48	15	3.1	132464
	60-20	1	60	20	3.1	144921
	80-26	1	80	26	3.1	144935
	120-40	1	120	40	3.1	144943

→ Continued on the next page



→ Continuation







**SRAT Heat shrinkable thick wall tube**

Technical data	Value	Test standard
<b>Physical properties</b>		
Hardness	40 Shore D	DIN 53 505
Elongation at break	350 %	IEC 60684-2
Tensile strength at break	13 MPa	IEC 60684-2
Longitudinal shrinkage	+5 % up to -15 %	IEC 60684-2
Shrink ratio	3:1	IEC 60684-2
Eccentricity expanded	50 %	IEC 60684-2
recovered	85 %	
<b>Thermal properties</b>		
Operating temperature range	-40 °C up to 120 °C	IEC 60684-2
Shrinkage temperature	> 125 °C	
Burning behaviour	not self-extinguishing	IEC 60684-2 method C
Flexibility at low temperatures	-40 °C	IEC 60684-2
Thermal ageing (168 h at 150 °C)		
Elongation at break	250 %	IEC 60684-2
Tensile strength at break	12 MPa	
<b>Electrical properties</b>		
Dielectric strength	20 kV/mm	IEC 60684-2
<b>Chemical properties</b>		
Corrosion	None	IEC 60684-2
Resistance to fungus and decay	Rate 1	IEC 60684-2



# CONNECTING TECHNOLOGY

## Low and Medium Voltage

	Compression connectors.....	198
	Compression cable lugs .....	204
	Screw connectors.....	207
	Screw cable lugs .....	208
	Branch ring connectors.....	209
	Miscellaneous .....	211



## DV-CU-V

### Compression connector Cu

according to DIN 46267, without separator, for low and medium voltage up to 10 kV

Strain-relieving connector (hexagonally compressed) for copper conductors, suitable for joints.

**Material**

- Copper tin-plated

**Application/Suitability**

- Connector for RM/SM copper conductors in compliance with DIN VDE 0295

**Test standards**

- DIN 46267, Part 1, non tension-proof press connections for copper conductors



**Scope of delivery**

Compression connector

Note: To be used with suitable crimping tool with DIN inserts.

**Dimensions**

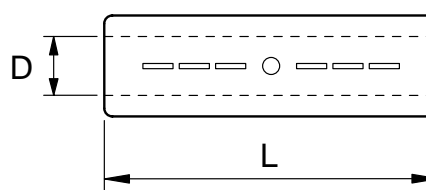

- L = Length
- D = Centric borehole
- Q = Nominal cross section
- K = Die code no.-outer diameter

Type	L mm	D mm	Q mm <sup>2</sup>	K mm	Art.-No.
6	30	3.8	6	5	125895
10	30	4.5	10	6	125950
16	50	5.5	16	8	125951
25	50	7.0	25	10	125952
35	50	8.2	35	12	125953
50	56	10.0	50	14	125954
70	56	11.5	70	16	125955
95	70	13.5	95	18	125956
120	70	15.5	120	20	125957
150	80	17.0	150	22	125958
185	85	19.0	185	25	125959
240	90	21.5	240	28	125960
300	100	24.5	300	32	125961
400	150	27.5	400	38	125962
500	160	31.0	500	42	125967
625	160	34.5	625	44	125963
800	200	40.0	800	52	125964
1000	200	44.0	1000	58	125965

CONNECTING TECHNOLOGY



## DVZ-CU-V-LD

### Compression connector Cu

according to DIN 46267, with separator, for low and medium voltage up to 10 kV

Strain-relieving connector (hexagonally compressed) with a separator for copper conductors, suitable for joints.

**Material**

- Copper tin-plated

**Application/Suitability**

- Especially for transition joints and pot end joints
- Connector for RM/SM copper conductors in compliance with DIN VDE 0295

**Test standards**

- DIN 46267, Part 1, non tension-proof press connections for copper conductors



**Scope of delivery**

Compression connector

Note: To be used with suitable crimping tool with DIN inserts.

**Dimensions**

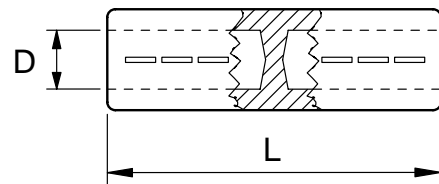

L = Length  
 D = Centric borehole  
 Q = Nominal cross section  
 K = Die code no.-outer diameter

Type	L mm	D mm	Q mm <sup>2</sup>	K mm	Art.-No.
DVZ-CU-V-LD	6	30	3.8	6	166374
	10	30	4.5	6	125966
	16	50	5.5	8	125897
	25	50	7.0	10	125898
	35	50	8.2	12	125899
	50	56	10.0	14	125900
	70	56	11.5	16	125901
	95	70	13.5	18	125902
	120	70	15.5	20	125903
	150	80	17.0	22	125904
	185	85	19.0	25	125905
	240	90	21.5	28	125906
	300	100	24.5	32	125907
	400	150	27.5	38	221276
	500	160	31.0	42	221277
625	160	34.5	44	189738	



## DV-AL

### Compression connector Al

according to DIN 46267, without separator, for low and medium voltage up to 10 kV

Strain-relieving connector (hexagonally compressed) for aluminium conductors, suitable for joints.

**Material**

- Blank aluminium

**Application/Suitability**

- Connector for RM/SM, SE and RE aluminium conductors in compliance with DIN VDE 0295

**Test standards**

- DIN 46267, Part 2, non tension-proof press connections for aluminium conductors



**Scope of delivery**

Compression connector

Note: To be used with suitable crimping tool with DIN inserts.

**Dimensions**

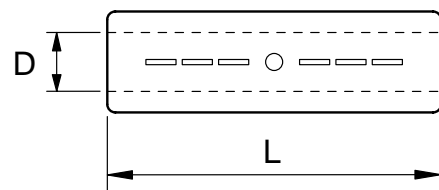

- L = Length
- D = Centric borehole
- Q = Nominal cross section
- RM = Round, stranded
- SM = Sector-shaped, stranded
- SE = Sector-shaped, massive
- RE = Round, massive
- K = Die code no.-outer diameter

Type	L mm	D mm	RM/SM	SE	RE	K mm	Art.-No.
			Q mm <sup>2</sup>				
DV-AL	16*	55	16	25	16	12	195344
	25	70	25	35	25	12	195345
	35	85	35	50	35	14	195346
	50	85	50	70	50	16	195347
	70	105	70	95		18	125947
	95	105	95	120		22	125948
	120	105	120	150		22	125888
	150	125	150	185		25	125889
	185	125	185	240		28	125890
	240	145	240	300		32	125891
	300	145	300			34	125892
	400	210	400			38	195348
	500	210	500			44	195349

\* does not comply with DIN standards

CONNECTING TECHNOLOGY





## DVZ-AL-LD

### Compression connector Al

according to DIN 46267, with separator, for low and medium voltage up to 10 kV

Strain-relieving connector (hexagonally compressed) with a separator for aluminium conductors, suitable for joints.

**Material**

- Blank aluminium

**Application/Suitability**

- Especially for transition joints and pot end joints
- Connector for RM/SM, SE and RE aluminium conductors in compliance with DIN VDE 0295

**Test standards**

- DIN 46267, Part 2, non tension-proof press connections for aluminium conductors



**Scope of delivery**

Compression connector

Note: To be used with suitable crimping tool with DIN inserts.

**Dimensions**

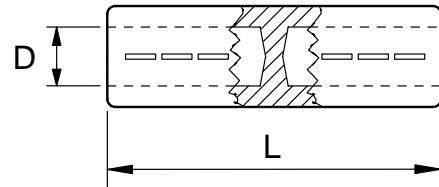

- L = Length
- D = Centric borehole
- Q = Nominal cross section
- RM = Round, stranded
- SM = Sector-shaped, stranded
- SE = Sector-shaped, massive
- K = Die code no.-outer diameter

Type		L mm	D mm	RM/SM	SE	K mm	Art.-No.
				Q mm <sup>2</sup>			
DVZ-AL-LD	16	75	5.4	16	25	12	198217
	25	75	6.8	25	35	12	198219
	35	90	8.0	35	50	14	198220
	50	90	9.8	50	70	16	198221
	70	110	11.2	70	95	18	198222
	95	110	13.2	95	120	22	198223
	120	110	14.7	120	150	22	198225
	150	130	16.3	150	185	25	198226
	185	130	18.3	185	240	28	198228
	240	150	21.0	240	300	32	198230
	300	155	23.3	300		34	198232

CONNECTING TECHNOLOGY



## DV-AL-CU

### Compression connector Al-Cu

according to DIN 40500, with separator, for low and medium voltage up to 10 kV

For round-compressed sector-shaped conductors.

**Material**

- Blank copper
- Blank aluminium

**Application/Suitability**

- Especially for transition joints and pot end joints

**Test standards**

- DIN 40500



**Scope of delivery**

Compression connector

Note: To be used with suitable crimping tool with DIN inserts.

**Dimensions**

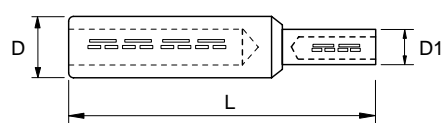

- L = Length
- D = Outer diameter on the aluminium side
- D1 = Outer diameter on the copper side
- Q = Nominal cross section
- RM = Round, stranded
- SM = Sector-shaped, stranded
- SE = Sector-shaped, massive
- K = Die code no.-outer diameter
- ∅ Al = Inner diameter on the aluminium side
- ∅ Cu = Inner diameter on the copper side

Type	L mm	D mm	D1 mm	Al RM	Al SE	Cu RM/SM	∅ Al	∅ Cu	Al-side/ CU-side	Art.-No.	
				Q mm <sup>2</sup>			mm		K mm		
DV-AL-CU	70-95/50	85.0	18.5	14.5	70	95	50	11.5	10.0	18/14	125870
	95-120/50	85.0	23.0	14.5	95	120	50	13.5	10.0	22/14	125872
	120-150/95	87.0	23.0	19.0	120	150	95	15.0	13.5	22/18	125875
	150-185/95	107.5	25.0	19.0	150	185	95	16.5	13.5	25/18	125876
	150-185/150	112.5	25.0	23.5	150	185	150	16.5	16.5	25/22	125877
	185-240/95	108.0	25.5	19.0	185	240	95	18.5	13.5	28/18	125878
	185-240/150	113.0	25.5	23.5	185	240	150	18.5	16.5	28/22	125879



## RH

### Reduction sleeve Cu

for low voltage

To allow applications on lower cross-sections, for copper compression connectors.

**Material**

- Blank copper

**Application/Suitability**

- For strain relief copper compression connectors

**Scope of delivery**

Reduction sleeve



**Dimensions**

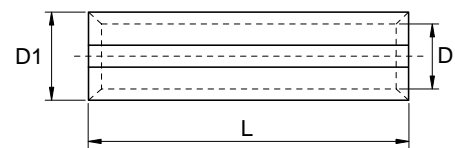

L = Length  
D = Centric borehole  
D1 = Outer diameter

Type	L mm	D mm	D1 mm	Art.-No.
RH	25/10	25	4.5	126242
	25/16	25	5.5	126243
	35/16	25	5.5	126245
	35/25	25	7.0	126246
	50/16	33	5.5	126247
	50/25	33	7.0	126248
	50/35	33	8.5	126249
	70/25	33	7.0	126250
	70/35	33	8.5	126251
	70/50	33	10.0	126252
	95/35	45	8.5	126253
	95/50	45	10.0	126254
	95/70	45	11.5	126255
	120/95	45	13.5	126258
	150/70	53	11.5	126259
	150/95	53	13.5	126260
	150/120	53	15.5	126261
	185/150	53	17.0	126264
	240/120	55	15.5	126265
	240/150	55	17.0	126266
240/185	55	19.0	126267	



## DK-CU-V

### Compression cable lug Cu

according to DIN 46235, for low and medium voltage

Cable lug (hexagonally compressed) for copper conductors, suitable for indoor cable terminations.

**Material**

- Copper tin-plated

**Application/Suitability**

- Cable lug for RM/SM copper conductors, in compliance with DIN VDE 0295

**Test standards**

- DIN 46235, cable lugs for press connections (contact plate for copper)



**Scope of delivery**

Compression cable lug

Note: To be used with suitable crimping tool with DIN inserts

**Dimensions**

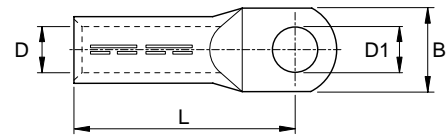

- L = Length
- B = Width
- D = Centric borehole
- D1 = Plate bore diameter
- K = Die code no.-outer diameter

Type	L mm	B mm	D mm	D1 mm	Nominal cross section mm <sup>2</sup>	K mm	Art.-No.
6/6	24	8.5	3.8	6.4	6	5	126040
10/8*	27	13	4.5	8.4	10	6	126044
16/8	36	13	5.5	8.4	16	8	126046
16/12*	36	18	5.5	13.0	16	8	126048
25/10	38	17	7.0	10.5	25	10	126051
25/12	38	19	7.0	13.0	25	10	126052
35/10	42	19	8.2	10.5	35	12	126054
35/12	42	21	8.2	13.0	35	12	126055
50/10	52	22	10.0	10.5	50	14	126059
50/12	52	24	10.0	13.0	50	14	126060
70/10	55	24	11.5	10.5	70	16	126064
70/12	55	24	11.5	13.0	70	16	126065
95/12	65	28	13.5	13.0	95	18	126070
95/16	65	32	13.5	17.0	95	18	126072
120/12	70	32	15.5	13.0	120	20	126074
120/16	70	32	15.5	17.0	120	20	126077
150/12	78	34	17.0	13.0	150	22	126080
150/16	78	34	17.0	17.0	150	22	126082
185/12	82	37	19.0	13.0	185	25	126085
185/16	82	37	19.0	17.0	185	25	126087
240/12	92	42	21.5	13.0	240	28	126089
240/16	92	42	21.5	17.0	240	28	126091
300/14*	100	48	24.5	15.0	300	32	126093
300/16	100	48	24.5	17.0	300	32	126094
400/16	115	55	27.5	17.0	400	38	126096
500/16*	125	60	31.0	17.0	500	42	126098
625/16*	135	60	34.5	17.0	625	44	126099
800/20	165	75	40.0	21.0	800	52	126102

\*does not comply with DIN standards

CONNECTING TECHNOLOGY



## DK-CU-V-LD

### Compression cable lug Cu

according to DIN 46235, longitudinally sealed, for low and medium voltage

Cable lug (hexagonally compressed) for copper conductors, suitable for outdoor cable terminations.

**Material**

- Copper tin-plated

**Application/Suitability**

- Cable lug for RM/SM copper conductors in compliance with DIN VDE 0295

**Test standards**

- DIN 46235, cable lugs for press connections (contact plate for copper)



**Scope of delivery**

Compression cable lug

Note: To be used with suitable crimping tool with DIN inserts

**Dimensions**

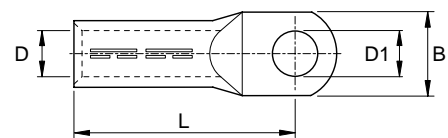

- L = Length
- B = Width
- D = Centric borehole
- D1 = Plate bore diameter
- K = Die code no.-outer diameter

Type	L mm	B mm	D mm	D1 mm	Nominal cross section mm <sup>2</sup>	K mm	Art.-No.
16/12*	36	18	5.5	13	16	8	159667
25/10	38	17	7.0	10.5	25	10	126134
35/12	42	21	8.2	13	35	12	159670
50/12	52	24	10.0	13	50	14	126135
70/12	55	24	11.5	13	70	16	148432
95/12	65	28	13.5	13	95	18	126136
DK-CU-V-LD 120/12	70	32	15.5	13	120	20	195350
150/16	78	34	17.0	17	150	22	126137
185/16	82	37	19.0	17	185	25	195351
240/16	92	42	21.5	17	240	28	126138
300/16	100	46	24.5	17	300	32	176369
400/16	115	54	27.5	17	400	38	126105
500/16*	125	60	31.0	17	500	42	126106

\* does not comply with DIN standards

CONNECTING TECHNOLOGY



## DK-AL-LD

### Compression cable lug Al

according to DIN 46235, longitudinally sealed, for low and medium voltage

Cable lug (hexagonally compressed) for aluminium conductors, suitable for indoor and outdoor cable terminations.

#### Material

- Blank aluminium

#### Application/Suitability

- Cable lug for RM/SM, SE and RE aluminium conductors in compliance with DIN VDE 0295

#### Test standards

- DIN 46329, cable lugs for press connections (contact plate for aluminium)



#### Scope of delivery

Compression cable lug

Note: To be used with suitable crimping tool with DIN inserts

#### Dimensions

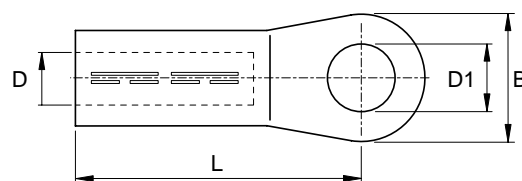

- L = Length
- B = Width
- D = Centric borehole
- D1 = Plate bore diameter
- Q = Nominal cross section
- RM = Round, stranded
- SM = Sector-shaped, stranded
- SE = Sector-shaped, massive
- RE = Round, massive
- K = Die code no.-outer diameter

Type	L mm	B mm	D mm	D1 mm	RM/SM	RE	SE	K mm	Art.-No.	
					Q mm <sup>2</sup>					
DK-AL-LD	16/10*	50	20	5.4	10.5	16	16	25	12	194950
	25/10	50	25	6.8	10.5	25	25	35	12	194949
	25/12	50	25	6.8	13.0	25	25	35	12	194947
	35/10	62	25	8.0	10.5	35	35	50	14	194945
	35/12	62	25	8.0	13.0	35	35	50	14	194944
	50/12	62	25	9.8	13.0	50	50	70	16	194943
	70/12	72	25	11.2	13.0	70		95	18	194942
	95/12	75	25	12.6	13.0	95		120	22	194941
	95/16*	80	30	12.6	17.0	95		120	22	194940
	120/12	80	30	14.7	13.0	120		150	22	194939
	120/16	80	30	14.7	17.0	120		150	22	194938
	150/12	90	30	16.3	13.0	150		185	25	194937
	150/16	90	30	16.3	17.0	150		185	25	194936
	185/12	91	30	18.3	13.0	185		240	28	194935
	185/16	91	30	18.3	17.0	185		240	28	194934
	240/16	103	38	21.0	17.0	240		300	32	194933
	300/16	103	38	23.3	17.0	300			34	194932
	400/20	116	38	26.0	21.0	400			38	194930
500/20	122	44	29.0	21.0	500			44	194908	

\* does not comply with DIN standards



## CSV-T Screw connector for Cu and Al

longitudinally sealed, with shear head bolts, with separator, for low voltage

Screw connector for RM/SM/RE/SE aluminium and copper conductors, suitable for straight-through and transition joints.

### Material

- Aluminium tin-plated

### Application/Suitability

- For connecting conductors class 1 and class 2 in compliance with DIN-EN / IEC 60228

### Test standards

- IEC 61238-1



### Scope of delivery

Screw connector, assembly instructions

Note: Cellpack counter-holder recommended for installation (see Accessories).

### Dimensions

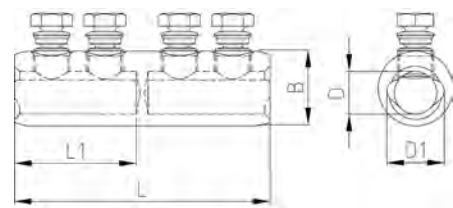

L = Length

L1 = Borehole depth

B = Width

D = Centric borehole

D1 = Outer diameter

Type		L mm	L1 mm	B mm	D mm	D1 mm	Number of bolts	Art.-No.
CSV-T	6-50	45	21	18	9.2	11.0	2	313462
	16-95	60	28	24	12.5	16.0	2	267685
	50-150	70	33	28	16.0	21.0	2	267708
	95-240	120	58	35	20.0	27.0	4	266811
	240-400	150	73	42	26.0	30.0	4	289677



## CSK

### Screw cable lug for Cu and Al

longitudinally sealed, with shear head bolts, for low and medium voltage

Screw cable lug for RM/SM/RE/SE aluminium and copper conductors, suitable for indoor and outdoor terminations.

#### Material

- Aluminium tin-plated

#### Application/Suitability

- For connecting conductors class 1 and class 2 in compliance with DIN-EN / IEC 60228

#### Test standards

- IEC 61238-1



#### Scope of delivery

Screw cable lug, assembly instructions

Note: Cellpack counter-holder recommended for installation (see Accessories).

#### Dimensions

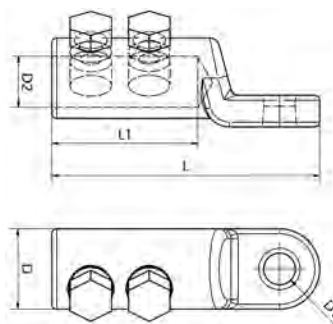

- L = Length
- L1 = Centric bore hole
- D = Outer diameter
- D1 = Plate bore diameter
- D2 = Bore hole diameter

Type	L mm	L1 mm	D mm	D1 mm	D2 mm	Number of bolts	Art.-No.
CSK	6-50	65	30	22	13	1	313461
	16-95	65	30	22	13	1	291122
	50-150	80	35	28	13	1	290812
	95-240	110	60	33	13	2	289968
	95-240 DM17	110	60	33	17	2	289984
	240-400*	135	75	40	17	2	291178

\* CSK 240-400: RM/RE cross section from 240 to 400 mm<sup>2</sup>, SM/SE cross section from 240 to 300 mm<sup>2</sup>





## HE 1/70/150 Branch clamp

for low voltage

For branching of 4-core SM/SE low voltage cables up to 1 kV.

### Characteristics

- Consists of sectional blocks with contacts, separators and inner hexagonal screws
- Connection of branch cable in visible area above the main cable
- Can be installed / operated while under voltage
- Safe and easy to handle

### Material

- Blank aluminium

### Application/Suitability

- For 4-core cables with PVC, XLPE, EPR insulation



### Scope of delivery

Branch clamp, insulating wedges, assembly instructions

Type	Number of conductors	Nominal cross section Main cable mm <sup>2</sup>		Nominal cross section Branch cable mm <sup>2</sup>	Art.-No.	
		SE	SM			
HE	1/70/150	4	95 - 150	70 - 120	16 - 50	193644



## Compact ring clamp Branch clamp

for low voltage

Branch clamp for aluminium sector shaped conductors.

### Characteristics

- Contact screws can be accessed from the side or from above
- No stripping of wires
- Can be installed / operated while under voltage
- Safe and easy to handle

### Material

- Aluminium blank

### Application/Suitability

- For 3- or 4-core cables with PVC, XLPE (VPE) EPR insulation



D = Circumscribed diameter  
RM = Round, stranded  
SE = Sector-shaped, massive

### Scope of delivery

Branch clamp



Type	Number of conductors	D mm	Cu/RM	Al/SE	Branch cable	Width across flat mm		Art.-No.	
			Cross section mm <sup>2</sup>			1	2		
Compact ring clamp	3x16-25/50	3	87	16 - 25		6 - 50	6	5	126194
	3x50/50	3	87	50 - 50		6 - 50	6	5	126195
	3x95/50	3	92	95 - 95		6 - 50	6	5	126197
	3x95/50-120/50	3	87	95 - 120	150	16 - 50	6	5	126196
	3x150/50	3	92	150 - 150		6 - 50	6	5	126200
	3x150/150	3	126	150 - 150		50 - 150	8	8	126199
	3x240se/70	3	109		240	6 - 70	8	5	126201
	4x16/50	4	83	16 - 16		6 - 50	6	5	126202
	4x25/50	4	83	25 - 25	35	6 - 50	6	5	126204
	4x35/50	4	83	35 - 35	50	6 - 50	6	5	126205
	4x50/50	4	83	50 - 50	70	6 - 50	6	5	126206
	4x70/50	4	93	70 - 70	95	6 - 50	6	5	126207
	4x95-120/50	4	93	95 - 120	150	6 - 50	6	5	126208
	4x150se/50	4	131		150	50 - 150	8	8	126209
	4x240se/70	4	124		240	6 - 70	8	5	126211

**ST-PO****Steel compression sleeve**

for low voltage

For connecting the steel oval anchor ropes in accordance with DIN 48201.

**Characteristics**

- Oval formed

**Material**

- Steel

**Scope of delivery**

Steel compression sleeve



Type		Nominal cross section		Identification number	Dimension for		Art.-No.
		FE mm <sup>2</sup>	Ø mm <sup>2</sup>		Steel mm	Iron (FE) mm	
ST-PO	50	50	9	PO 20	19 x 1.8 mm	7 x 3	125909

**AK****Screw branch clamp Al-Cu**

for cast resin straight-through and branch joints, for low voltage

Suitable for connecting and branching aluminium and copper conductors.

**Characteristics**

- Brass clamp tin-plated, with a grey polycarbonate
- Separable, main cable must not be cut

**Scope of delivery**

Screw branch clamp

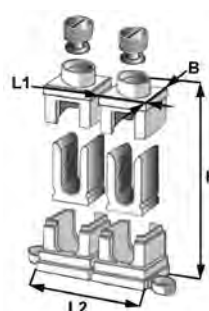
**Dimensions**

Type	L1 mm	L2 mm	B mm	H mm	max. Nominal cross section mm <sup>2</sup>		Art.-No.
					Main cable	Branch cable	
AK	6	11.5	9	19	6	6	131050
	10	12.5	10.5	22	10	10	131049
	16	14	12	26	16	16	131048
	25	17.5	14	29	25	25	131047
	35	21	17.5	41	35	35	131045
	50	23	50	19	46	50	258494
	70	28	57	24	50	70	258495
	150	37	64	33	65	150	258496

**FK, FKS****Split bolt clamp**

for cast resin straight-through and branch joints, for low voltage

For use as branch clamp or connector clamp for copper conductors.

**Material**

- FK = Electrolyte copper
- FKS = Bronze with copper nut

**Scope of delivery**

Split bolt clamp

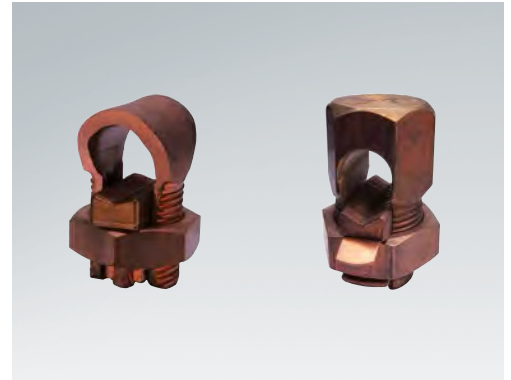

Type		Height mm	Main cable		Nominal cross section Branch cable mm <sup>2</sup>	Width across flat 1   2 mm		Art.-No.
			Cross section mm <sup>2</sup>	Diameter mm				
FK	10	21	10	4.1	2.5 - 10	13		126179
	16	23	16	5.1	2.5 - 16	17		126180
	25	30	25	6.4	4 - 25	19		126181
	35	35	35	7.5	4 - 35	22		126182
	50	50	50	9.0	10 - 50	24		126183
	95	50	95	12.5	10 - 70	32		126184
	150	55	150	15.7	16 - 95	36		126185
FKS	10	26	10	4.0	2.5 - 10	17	14	126186
	16	31	16	5.0	2.5 - 16	19	16	126187
	25	35	25	6.0	4 - 25	22	18	126188
	35	40	35	8.0	4 - 35	24	20	126189
	50	46	50	9.0	10 - 50	27	22	126190
	70/95	55	95	13.0		32	27	126191
	120/150	70	150	16.0		41	36	126192
	185/240		240	21.0		50	41	126193

**V, VI, VS****Screw connector Al-Cu**

for low voltage

Screw connector for aluminium and copper conductors with grub screws.

**Material**

- Aluminium

**Application/Suitability**

- V = Blank
- VI = Insulated
- VS = For heat shrinkable cable joints

**Scope of delivery**

Screw connector

Type		Art.-No.
<b>V = Blank</b>		
<b>V</b>	4-16	126169
	16-50	126170
<b>VI = Insulated</b>		
<b>VI</b>	4-16	126172
	16-50	126164
	50-150	126165
<b>VS = For heat shrinkable cable joints</b>		
<b>VS</b>	6-50	126214
	50-150	166373

**KP****Branch clamp**

for cast resin branch joints, for low voltage

Used for branching of copper cables and signal conductors.

**Characteristics**

- Plastic insulating housing with tin-plated cutting contact
- Insulated cable exit allows assembly under voltage

**Scope of delivery**

Branch clamp

Type	B mm	H mm	Nominal cross section mm <sup>2</sup>		Art.-No.	
			main cable	branch cable		
KP	1.5-10	23	20	1.5 - 10	1.5 - 10	126216

## AVS, AVUS Wire connector

for telecommunication and signal cables, DIN 47627

Suitable for connecting polymeric-insulated telecommunication and signal cables e.g. in heat shrinkable telecommunication joints, as well as for modern building management systems (such as communication, telephone or surveillance systems and bus systems).

### Characteristics

- Grease-filled to protect against corrosion
- Shock-resistant polymeric housing
- Reliable connection due to U contact principle
- Stripping, connection and insulation carried out in a single step
- Space-saving design, easy assembly
- High electrical insulating values
- High mechanical and thermal strength

### Application/Suitability

- Switching while under voltage (AVUS)



### Colours



Transparent

### Types

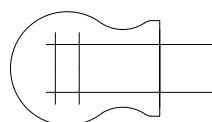

AVS2-9

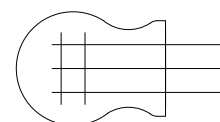

AVS3-9

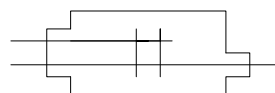

AVUS3-9

Type		Colours	Number of conductors	Conductor-Ø mm	Core-Ø mm	Art.-No.
AVS	2-9	Transparent	2	0.4 - 0.9	2	145624
	3-9	Transparent	3	0.4 - 0.9	2	145622
AVUS	3-9	Transparent	3	0.4 - 0.9	2	147217

Technical data	Value	Test standard
Insulation resistance	106 MΩ	DIN 47627
Voltage strength between conductors	500 V	DIN 47627
Modification of contact resistance	2 mΩ	DIN 47627
Surge voltage resistance	5 kV	DIN 47627
Impulse current resistance	no burn marks in contact area	DIN 47627



**DR****Heat shrinkable crimp connector**

insulated with heat shrinkable tube, with adhesive, for low voltage

Durable and reliable connector for application in areas under extreme conditions. Hot melt adhesive completely seals the connection area.

**Characteristics**

- 100 % waterproof
- Superior electrical properties
- High mechanical strength

**Application/Suitability**

- Indoor
- Outdoor
- Underground
- Water

**Scope of delivery**

1 PU heat shrinkable crimp connectors

Note: For compression and a proper conductor/heat shrinkable compression connector contact, use a suitable parallel crimping tool e.g. P22 mechanical crimping plier.

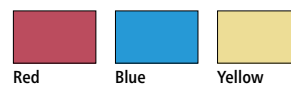
**Colours**

Type		Colours	Piece	Nominal cross section mm <sup>2</sup>	Art.-No.
DR	1	Red	20	0.5 - 1	125914
	1	Red	100	0.5 - 1	145626
	2	Blue	20	1.5 - 2.5	125915
	2	Blue	100	1.5 - 2.5	145627
	3	Yellow	20	4 - 6	125916
	3	Yellow	100	4 - 6	145628

Technical data	Value
Tensile strength	22.5 MPa
Heat resistance (168 h at 175 °C)	No breaking
Heat shock (4 h at 225 °C)	No breaking
Temperature range	-55 °C up to 105 °C
Shrinkage temperature	> 90 °C
Dielectric strength	12 kV/mm
Corrosion	None
Water absorption	max. 0.5 %

## CL Earthing clamp

for low voltage

Suitable for CL-armouring and tape screens, for earthing of cable ends and for continuity in straight-through joints.

### Material

- Copper tin-plated

### Application/Suitability

- Enables solder-free electrical connection for armourings and cable screens



Scope of delivery  
Earthing clamp

Type	Cross section transition mm <sup>2</sup>	Polymeric cable unarmoured	
		 4x	
		Nominal cross section per conductor mm <sup>2</sup>	Art.-No.
CL 6	≤ 6	2.5 - 16	126301
CL 16	≤ 16	16 - 240	126302

## EGA Earthing set

for cables with tape screen and/or armouring for cable terminations, for low and medium voltage

EGA earthing set for cable terminations for 1-core cables with copper tape or aluminium screen (Fig. 1) and for unarmoured 3-core cables (Fig. 3). Kit components: 3 flat-rolled copper braids and 3 pressure springs.

### Characteristics

- Quick, safe and easy assembly
- Superior electrical properties
- High mechanical strength

### Application/Suitability

- Earthing continuity and earth bonding
- For cast resin, heat shrinkable and slip-on cable accessories
- Enables solder-free electrical connection of metal cable components (screen, armouring, metal sheath)

### Termination types

- **1]** 1-core cables with copper tape or aluminium screens unarmoured
- **2]** 1-core cables with copper tape or aluminium screens armoured, please order extra pressure spring (ZR1)
- **3]** 3-core cables with copper tape or aluminium screens unarmoured
- **4]** 3-core cables with copper tape or aluminium screens armoured, please order extra pressure spring (ZR2)

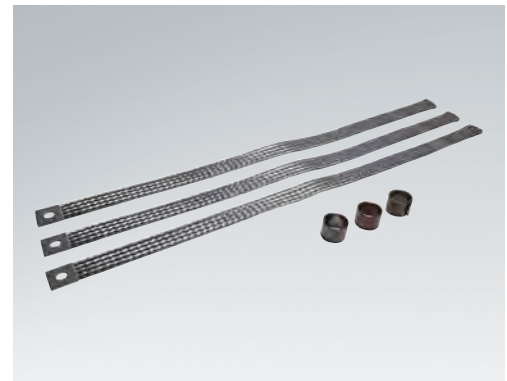

### Termination types

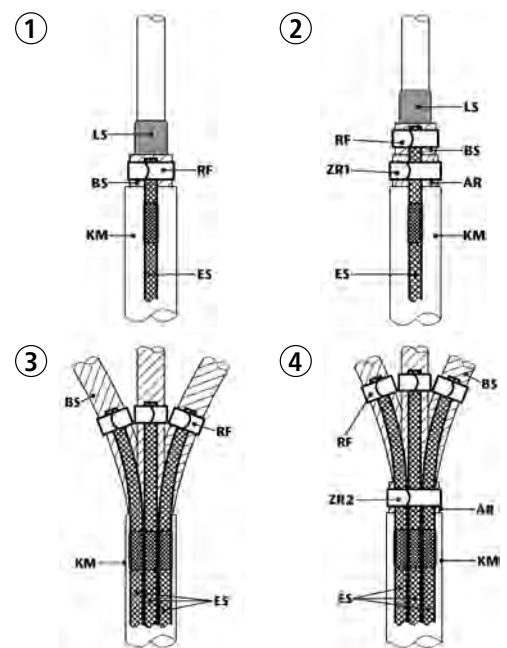

LS = External conducting layer  
 BS = Cu-tape screen  
 KM = Cable sheath  
 RF = Type RF pressure spring  
 ES = Copper braid, flat tin-plated  
 AR = Armouring  
 ZR1 = Extra pressure spring 1-core  
 ZR2 = Extra pressure spring 3-core

### Scope of delivery

1 set for 3 phases: Copper braids, pressure springs RF

Note: Additional pressure springs RF (ZR1/ZR2) for armoured cables to be ordered separately (see Accessories).

Type	L mm	Pressure spring	Copper cord		Nominal cross section mm <sup>2</sup>					ZR1	ZR2	Art.-No.	
			Ø hole mm	Nominal cross section mm <sup>2</sup>	7.2 kV	12 kV	17.5 kV	24 kV	36 kV				
EGA	16-2	500	RF 2	8.5	16	150	120	70	50		RF3	RF5	143502
	16-3	500	RF 3	8.5	16	150 - 240	120 - 240	95 - 185	70 - 150	120	RF4	RF5	143503
	25-3	500	RF 3	10.5	25	150 - 500	120 - 500	95 - 300	70 - 300	70 - 240	RF4	RF6	143505
	25-4	500	RF 4	10.5	25					150 - 300	RF5	RF6	143506
	35-4	500	RF 4	10.5	35	500 - 1000	500 - 1000	400 - 800	300 - 800	185 - 500	RF5	RF6	143508
	35-5	500	RF 5	10.5	35			800 - 1000	800 - 1000	500 - 1000	RF6		143509

**AUF****Armour transition for 3-core joints**

for armoured cables, for medium voltage

Armour continuity set for armoured 3-core cable joints.

**Characteristics**

- Quick, safe and easy assembly
- Superior electrical properties
- High mechanical strength

**Application/Suitability**

- Earthing continuity and earth bonding
- For cast resin, heat shrinkable and slip-on cable accessories
- Enables solder-free electrical connection of metal cable components (screen, armouring, metal sheath)

**Scope of delivery**

1 set for 3 phases: Copper braid, pressure springs RF

Note: Additional pressure springs RF (ZR1/ZR2) for armoured cables to be ordered separately (see Accessories).

**Dimensions**

L = Length



1. Pressure spring

2. Copper braid

3. Pressure spring

Type	L mm	Pressure spring	Copper cord Nominal cross section mm <sup>2</sup>	Nominal cross section mm <sup>2</sup>					Art.-No.	
				7.2 kV	12 kV	17.5 kV	24 kV	36 kV		
AUF	5	1200	RF 5	35	300	240	240	150	70	195367
	6	1200	RF 6	35	400	300 - 400	300 - 400	185 - 300	95 - 300	195368

# ELECTRICAL INSULATION AND MOUNTING TAPES

	Electrical insulation and mounting tapes . . . . .	223
	Additional tapes . . . . .	240
	Miscellaneous . . . . .	244

## Overview: Cellpack Electrical insulation and mounting tapes / Additional tapes

Products	Properties						
	insulating	self-amalgamating	inscribable	stabilized against UV rays	conductive	heat-proof	colour-fast
<b>Electrical insulation and mounting tapes</b>							
Premio 233	●	-	-	●	-	-	-
Premio 235	●	-	-	●	-	-	-
Premio 388	●	-	-	-	-	-	-
Premio 845	-	-	-	●	-	-	-
Premio 1130	●	-	●	-	-	●	-
Premio 1180	●	-	●	-	-	●	-
Premio 2281	-	-	-	-	●	-	-
Premio 5584	-	-	-	●	-	-	-
No. 128	●	-	-	●	-	-	-
No. 228	●	-	-	●	-	-	-
No. 64	-	●	-	-	-	-	-
No. 90	-	-	●	-	-	-	-
No. 63	-	-	-	-	●	-	-
No. 60, No. 62	●	●	-	●	-	-	-
No. 61	-	●	-	-	●	-	-
<b>Additional tapes</b>							
HKB	●	-	-	-	-	-	-
No. 26	-	-	-	-	-	-	●
No. 72	-	●	-	-	-	-	-
KRS	-	●	-	-	-	-	-

- available
- not available



## Premio 233

### PVC electrical insulation tape

for insulation and bundling, in practical plastic box

Particularly flexible and UV-resistant PVC electrical insulation tape.

#### Characteristics

- Moisture-resistant
- Oil-resistant
- Resistant to dilute acids and alkalis
- Stabilized against UV rays
- High flexibility
- Withstands high electrical stresses
- Easily processed even at low temperatures
- In practical plastic box

#### Application/Suitability

- As electrical insulation for applications up to 1 kV
- Bundling

#### Test standards

- Approved according VDE

#### Material

- PVC



#### Scope of delivery

PVC electrical insulation tape

#### Colours



Black

Type	Colours	Length m	Width mm	Thickness mm	Art.-No.
Premio 233	Black	6	19	0.18	223609
	Black	20	19	0.18	223607
	Black	33	19	0.18	223606

Technical data	Value
min. Elongation at break	285 %
Adhesive strength	3.3 N/cm
Insulation resistance	1 x 10 <sup>5</sup> MΩ
Dielectric strength	45 kV/mm
max. Long-term heat resistance	105 °C



## Premio 235 PVC electrical insulation tape

for marking and bundling, in practical plastic box

Particularly flexible and UV-resistant PVC electrical insulation tape.

### Characteristics

- Moisture-resistant
- Oil-resistant
- Resistant to dilute acids and alkalis
- Stabilized against UV rays
- High flexibility
- Easily processed even at low temperatures
- In practical plastic box

### Application/Suitability

- As electrical insulation for applications up to 1 kV
- Colour-coding and marking

### Material

- PVC

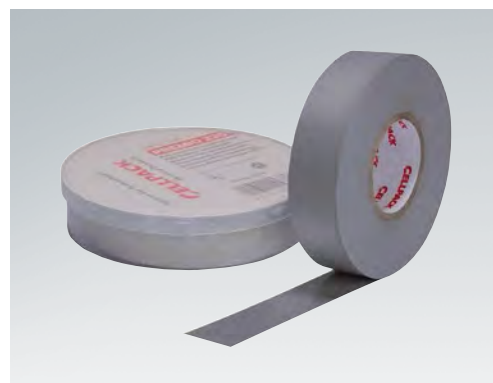

### Scope of delivery

PVC electrical insulation tape

### Colours

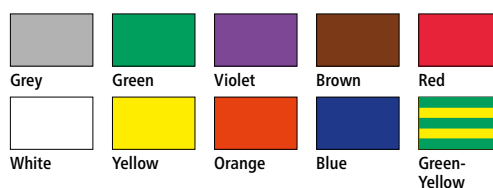

Type	Colours	Length m	Width mm	Thickness mm	Art.-No.
Premio 235	Grey	20	19	0.18	223597
	Green	20	19	0.18	223600
	Violet	20	19	0.18	223595
	Brown	20	19	0.18	223598
	Red	20	19	0.18	223603
	White	20	19	0.18	223594
	Yellow	20	19	0.18	223599
	Orange	20	19	0.18	223596
	Blue	20	19	0.18	223602
	Green-Yellow	20	19	0.18	252110

Technical data	Value
min. Elongation at break	285 %
Adhesive strength	2.2 N/cm
Insulation resistance	1 x 10 <sup>5</sup> MΩ
Dielectric strength	45 kV/mm
max. Long-term heat resistance	105 °C





## Premio 388

### All-weather PVC tape

for insulation and bundling, in practical plastic box

Particularly weatherproof PVC all-weather tape.

#### Characteristics

- Self-extinguishing
- Resistant to dilute acids and alkalis
- Good adhesive properties
- Weatherproof
- Easily processed even at low temperatures
- In practical plastic box

#### Application/Suitability

- Bundling
- As electrical insulation for applications up to 1 kV

#### Material

- PVC



#### Scope of delivery

All-weather PVC tape

#### Colours



Black

Type	Colours	Length m	Width mm	Thickness mm	Art.-No.
Premio 388	Black	6	19	0.22	223605
	Black	20	19	0.22	223604

Technical data	Value
min. Elongation at break	298 %
Adhesive strength	2.8 N/cm
Insulation resistance	1 x 10 <sup>5</sup> MΩ
Dielectric strength	45 kV/mm
max. Long-term heat resistance	105 °C



## Premio 845 Tape for cable bundle

for short-circuit-resistant bundling and cable fixing

Fibreglass-reinforced polyester tape on one side coated with adhesive.

### Characteristics

- Stable core
- Moisture-resistant
- Stabilized against UV rays
- Extreme tear resistance
- Excellent adhesion to a variety of materials
- Weatherproof

### Application/Suitability

- Short-circuit-resistant bundling of cables
- Affixing of cables
- Especially suitable for fixation systems under mechanical tension

### Material

- PES/Fibreglass reinforced

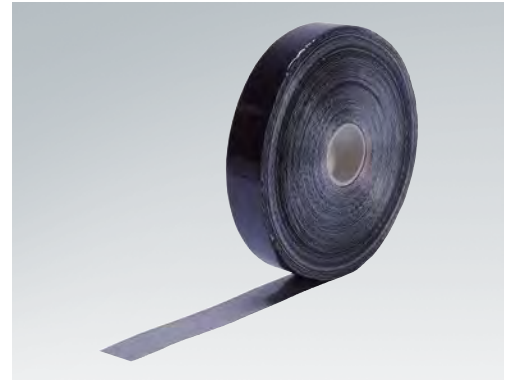

### Scope of delivery

Tape for cable bundle

#### Formular for number of tape layers and bundling distances

$$\text{Maximum distance between 2 bundlings } L_{\max} = 280 \times \frac{d^2}{I}$$

$$\text{Layers of tape } n \text{ for chosen } L_{\max} : n = \frac{I^2 \times L_{\max}}{6200 \times d \times b} + 1$$

I = Short circuit in kA

d = Cable diameter in cm

b = Tape width in cm

$L_{\max}$  = Bundling distances in cm

### Colours



Black

Type	Colours	Length m	Width mm	Thickness mm	Art.-No.
Premio 845	Black	20	19	0.18	223592
	Black	50	19	0.18	223591
	Black	50	25	0.18	223590

Technical data	Value
min. Elongation at break	4 %
Adhesive strength	4.8 N/cm
max. Long-term heat resistance	100 °C



## Premio 1130

### Fibreglass tape 130 °C

for heat-proof electrical and mechanical insulation

Self-adhesive fibreglass tape coated with heat-hardening silicone adhesive, temperature-resistant up to 130 °C.

#### Characteristics

- Stable core
- Inscrutable
- Extreme tear resistance
- Superior thermal stability

#### Application/Suitability

- Insulation of highly exothermic electrical components
- As a cable protection during welding and soldering
- As a protection wrapping against radiant heat

#### Material

- Fibreglass reinforcement

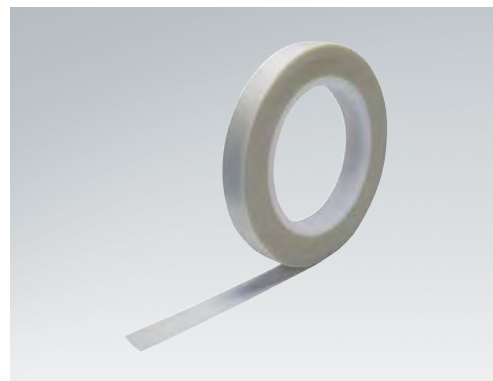

Scope of delivery  
Fibreglass tape

#### Colours



White

Type	Colours	Length m	Width mm	Thickness mm	Art.-No.
Premio 1130	White	33	12	0.18	223585
	White	33	19	0.18	223583

Technical data	Value
min. Elongation at break	8 %
Adhesive strength	3.8 N/cm
Insulation resistance	$1.5 \times 10^3 \text{ M}\Omega$
Dielectric strength	12.7 kV/mm
max. Long-term heat resistance	130 °C



## Premio 1180 Fibreglass tape 180 °C

for heat-proof electrical and mechanical insulation

Self-adhesive fibreglass tape coated with heat-hardening silicone adhesive, temperature-resistant up to 180 °C.

### Characteristics

- Stable core
- Inscrutable
- Extreme tear resistance
- Superior thermal stability

### Application/Suitability

- Insulation of highly exothermic electrical components
- As a cable protection during welding and soldering
- As a protection wrapping against radiant heat

### Material

- Fibreglass reinforcement

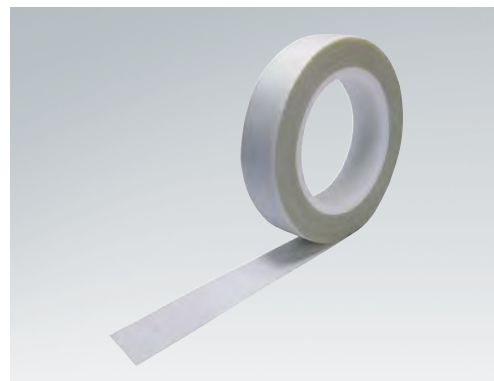

Scope of delivery  
Fibreglass tape

### Colours



White

Type	Colours	Length m	Width mm	Thickness mm	Art.-No.
Premio 1180	White	33	15	0.18	223581
	White	33	25	0.18	223580

Technical data	Value
min. Elongation at break	8 %
Adhesive strength	3.8 N/cm
Insulation resistance	1.5 x 10 <sup>3</sup> MΩ
Dielectric strength	12.7 kV/mm
max. Long-term heat resistance	180 °C



## Premio 2281 Copper foil

for discharge of electrostatic charge and screening of components, in practical plastic box

Copper foil with conductive acrylic adhesive.

### Characteristics

- Resistant to dilute acids and alkalis
- Can be soldered
- In practical plastic box

### Application/Suitability

- Discharge of electrostatic charge and screening of components and appliances against electro-magnetic fields

### Material

- Copper foil

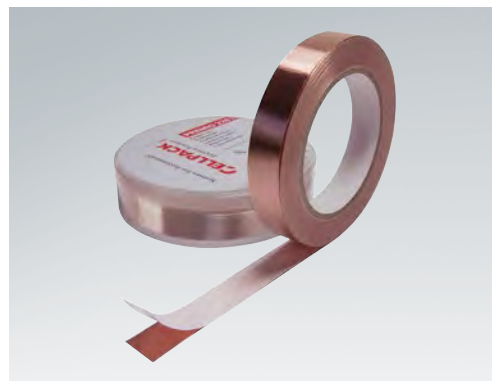

Scope of delivery  
Copper foil

### Colours



Copper

Type	Colours	Length m	Width mm	Thickness mm	Art.-No.
Premio 2281	Copper	33	9	0.06	223578
	Copper	33	12	0.06	223577
	Copper	33	19	0.06	223576

Technical data	Value
Adhesive strength	5.0 N/cm
max. Long-term heat resistance	155 °C



## Premio 5584 Self-adhesive foam tape

for universal fixation

Double-sided all-purpose foam adhesive tape with high-quality acrylic adhesive.

### Characteristics

- Stable core
- Moisture-resistant
- Resistant to dilute acids and alkalis
- Stabilized against UV rays
- Non-corrosive
- Double-sided acrylic adhesive
- High abrasion resistance

### Application/Suitability

- Waterproofing
- Adhesive and fixing tape

### Material

- Polyethylene foam

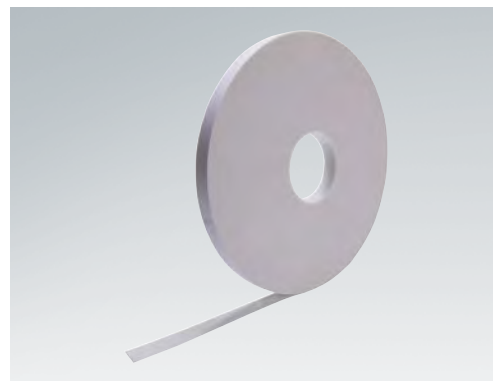

### Scope of delivery

Self-adhesive foam tape

### Colours



White

Type	Colours	Length m	Width mm	Thickness mm	Art.-No.
Premio 5584	White	60	19	1	223575
	White	60	25	1	223574

Technical data	Value
Adhesive strength	7.2 N/cm
Working temperature min.	10 °C
max.	40 °C
Heat resistance min.	-40 °C
max.	100 °C



## No. 128

### PVC insulation tape

for marking, bundling and insulating

Flexible, UV-resistant PVC insulation tape.

#### Characteristics

- Synthetic rubber adhesive
- Moisture-resistant
- Oil-resistant
- Resistant to dilute acids and alkalis
- Stabilized against UV rays
- High flexibility
- Withstands high electrical stresses
- Good adhesive properties
- Easy processing

#### Application/Suitability

- Sealing
- Padding of cable insulation
- Bundling
- Reinforcing
- As insulation of electrical and telecommunication cables
- Marking of insulation with high mechanical tension requirements

#### Test standards

- Approved according VDE

#### Material

- PVC



#### Colours

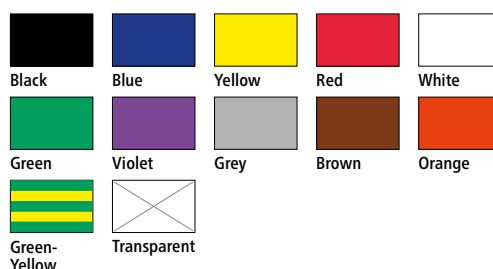

#### Scope of delivery

PVC insulation tape

Type	Colours	Length m	Width mm	Thickness mm	Art.-No.
No. 128	Black	10	15	0.15	145821
	Blue	10	15	0.15	145825
	Yellow	10	15	0.15	145826
	Red	10	15	0.15	145827
	White	10	15	0.15	145828
	Green	10	15	0.15	145829
	Violet	10	15	0.15	145830
	Grey	10	15	0.15	145831
	Brown	10	15	0.15	145832
	Orange	10	15	0.15	145822
	Green-Yellow	10	15	0.15	145823
	Transparent	10	15	0.15	145824
	Black	10	19	0.15	145806
	Blue	10	19	0.15	145810
	Yellow	10	19	0.15	145811
	Red	10	19	0.15	145812
	White	10	19	0.15	145813
	Green	10	19	0.15	145814
	Violet	10	19	0.15	145815
	Grey	10	19	0.15	145816
	Brown	10	19	0.15	145817
	Orange	10	19	0.15	145807
	Green-Yellow	10	19	0.15	145808
	Transparent	10	19	0.15	145809

ELECTRICAL INSULATION AND MOUNTING TAPES

→ Continued on the next page



→ Continuation

**No. 128 PVC insulation tape**

Type	Colours	Length m	Width mm	Thickness mm	Art.-No.
No. 128	Black	25	19	0.15	145794
	Blue	25	19	0.15	145798
	Yellow	25	19	0.15	145799
	Red	25	19	0.15	145800
	White	25	19	0.15	145801
	Green	25	19	0.15	145802
	Violet	25	19	0.15	145803
	Grey	25	19	0.15	145804
	Brown	25	19	0.15	145805
	Orange	25	19	0.15	145795
	Green-Yellow	25	19	0.15	145796
	Transparent	25	19	0.15	145797
	Black	25	25	0.15	145773
	Blue	25	25	0.15	145776
	Yellow	25	25	0.15	145777
	Red	25	25	0.15	145778
	White	25	25	0.15	145779
	Green	25	25	0.15	145780
	Violet	25	25	0.15	145781
	Grey	25	25	0.15	145782
	Brown	25	25	0.15	145783
	Green-Yellow	25	25	0.15	145774
	Transparent	25	25	0.15	145775
	Black	25	30	0.15	145784
	Blue	25	30	0.15	145786
	Yellow	25	30	0.15	145787
	Red	25	30	0.15	145788
	White	25	30	0.15	145789
	Green	25	30	0.15	145790
	Violet	25	30	0.15	145791
	Grey	25	30	0.15	145792
	Brown	25	30	0.15	145793
	Green-Yellow	25	30	0.15	145785
	Black	25	38	0.15	145771
	Black	25	50	0.15	145772

Technical data	Value
min. Elongation at break	170 %
Tensile strength at break	30 MPa
Dielectric strength	40 kV/mm
max. Long-term heat resistance	90 °C
Unwinding force	1.8 N/cm





## No. 228

### PVC insulation tape

for marking, bundling and insulating

Flexible, UV-resistant PVC insulation tape.

#### Characteristics

- Synthetic rubber adhesive
- Moisture-resistant
- Oil-resistant
- Resistant to dilute acids and alkalis
- Stabilized against UV rays
- High flexibility
- Good adhesive properties
- Easy processing

#### Application/Suitability

- Sealing
- Padding of cable insulation
- Bundling
- Reinforcing
- As insulation of electrical and tele-communication cables
- Marking of insulation with high mechanical tension requirements

#### Test standards

- Approved according VDE

#### Material

- PVC

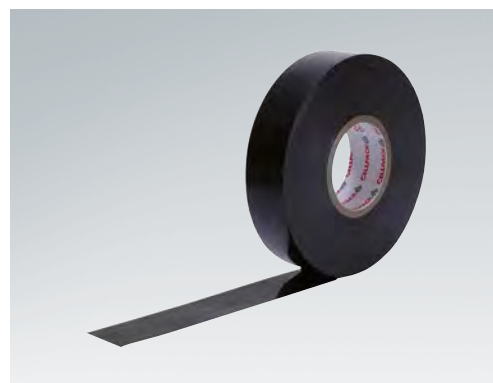

#### Colours

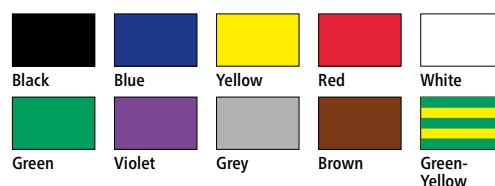

#### Scope of delivery

PVC insulation tape

Type	Colours	Length m	Width mm	Thickness mm	Art.-No.
No. 228	Black	20	12	0.19	130519
	Black	20	15	0.19	130615
	Black	10	19	0.19	130660
	Blue	10	19	0.19	130668
	Yellow	10	19	0.19	130664
	Red	10	19	0.19	130662
	White	10	19	0.19	130665
	Green	10	19	0.19	130667
	Violet	10	19	0.19	145819
	Grey	10	19	0.19	130666
	Brown	10	19	0.19	145820
	Green-Yellow	10	19	0.19	130675
	Black	20	19	0.19	130618
	Blue	20	19	0.19	130652
	Yellow	20	19	0.19	130622
	Red	20	19	0.19	130619
	White	20	19	0.19	130624
	Green	20	19	0.19	130629
	Violet	20	19	0.19	125476
	Grey	20	19	0.19	130626
	Brown	20	19	0.19	125475
	Green-Yellow	20	19	0.19	130630
	Black	20	25	0.19	130654
	Black	20	30	0.19	130655
	Black	20	38	0.19	130656
	Black	20	50	0.19	125483

ELECTRICAL INSULATION AND MOUNTING TAPES

Technical data	Value
min. Elongation at break	160 %
Adhesive strength	2.0 N/cm
Tensile strength at break	18 MPa
Dielectric strength	40 kV/mm
max. Long-term heat resistance	90 °C
Unwinding force	2.2 N/cm



## No. 64 Sealing tape

for permanently flexible sealing, self-amalgamating

Universally suitable, auto-amalgamating, to seal homogeneously or upholstering cables and conductors.

### Characteristics

- Synthetic rubber adhesive
- Self-amalgamating
- Corrosion-resistant
- Ozone-resistant
- Permanently flexible
- Superior dielectric properties
- Excellent adherence to metal, glass, rubber and plastic
- Superior physical properties

### Application/Suitability

- Sealing of cable and conductor interstices
- Repairing of damaged cable sheaths
- Water-resistant sealing of cable entry points
- Padding of cable insulation
- Suitable for connections using acrylic and epoxy resin compounds
- Protection against dust, moisture and corrosion

### Material

- Butyl-/Rubber based

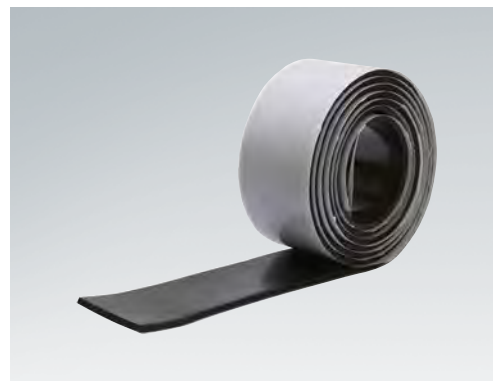

### Colours



Black

### Scope of delivery

Sealing tape

Type	Colours	Length m	Width mm	Thickness mm	Art.-No.
No. 64	Black	1.5	38	3.2	125591

Technical data	Value
Dielectric constant	3.1
Dissipation factor (50 Hz)	0.025
Dielectric strength	16 kV/mm
Specific volume resistivity	1 x 10 <sup>12</sup> MΩ
Water absorption	0.1 %



## No. 90

### Cloth tape

for marking and labeling

High quality waterproof sealing cloth tape with synthetic rubber adhesive.

#### Characteristics

- Synthetic rubber adhesive
- Hard-wearing
- Can be labelled at all times
- Easy to tear
- Easy to unroll
- Superior ageing resistance
- Can be adjusted to suit the form better
- Excellent adherence to a wide range of substances
- Easy processing

#### Application/Suitability

- Marking
- Labelling
- Affixing
- Bundling

#### Material

- Coated cotton

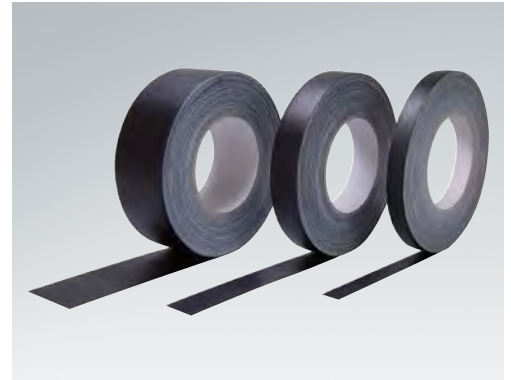

#### Colours

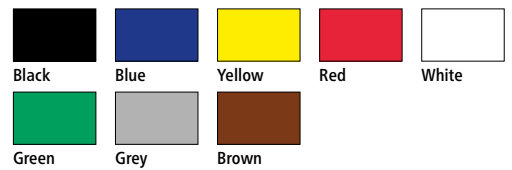

#### Scope of delivery

Cloth tape

Type	Colours	Length m	Width mm	Thickness mm	Art.-No.
No. 90	Black	50	12	0.31	146012
	Yellow	50	12	0.31	146016
	Red	50	12	0.31	146018
	White	50	12	0.31	146020
	Grey	50	12	0.31	146024
	Black	25	15	0.31	145938
	Yellow	25	15	0.31	145941
	White	25	15	0.31	145945
	Grey	25	15	0.31	145948
	Black	50	15	0.31	146028
	Blue	50	15	0.31	146030
	Yellow	50	15	0.31	146032
	Red	50	15	0.31	146034
	White	50	15	0.31	146036
	Green	50	15	0.31	146038
	Grey	50	15	0.31	146040
	Black	25	19	0.31	145951
	Yellow	25	19	0.31	145954
	White	25	19	0.31	145957
	Grey	25	19	0.31	145961
	Black	50	19	0.31	146044
	Blue	50	19	0.31	146046
	Yellow	50	19	0.31	146048
	Red	50	19	0.31	146050
	White	50	19	0.31	146052
	Green	50	19	0.31	146054
	Grey	50	19	0.31	146056
	Brown	50	19	0.31	146058
	Black	25	25	0.31	145964
	Yellow	25	25	0.31	145967
	White	25	25	0.31	145970
	Grey	25	25	0.31	145973

→ Continued on the next page



→ Continuation  
**No. 90 Cloth tape**

Type	Colours	Length m	Width mm	Thickness mm	Art.-No.
No. 90	Black	50	25	0.31	146060
	Yellow	50	25	0.31	146064
	Red	50	25	0.31	146066
	White	50	25	0.31	146068
	Grey	50	25	0.31	146072
	Black	25	50	0.31	145988
	Yellow	25	50	0.31	145991
	White	25	50	0.31	145994
	Grey	25	50	0.31	145997
	Black	50	50	0.31	146107
	Blue	50	50	0.31	146109
	Yellow	50	50	0.31	146111
	Red	50	50	0.31	146113
	White	50	50	0.31	146115
	Grey	50	50	0.31	146119

Technical data	Value
min. Elongation at break	5 %
Adhesive strength on steel	6.7 N/cm
Unwinding force	2.8 N/cm



## No. 63

### Copper braid tape

for shielding and potential control

#### Characteristics

- Wrinkle-free application to all contours
- High flexibility
- Unbreakable

#### Application/Suitability

- Earthing continuity and earth bonding
- Electrostatic shielding continuity
- Semi-conducting continuity for connectors
- Voltage grading continuity

#### Material

- Braided tinned copper wires



#### Scope of delivery

Copper braid tape

#### Colours



Silver

Type	Colours	Length m	Width mm	Thickness mm	Art.-No.
No. 63	Silver	5	25	0.5	126313
	Silver	9.1	25	0.5	126303
	Silver	5	60	0.5	126315
	Silver	10	60	0.5	126316

**No. 60, No. 62****High voltage insulation tape**

for insulation and padding, self-amalgamating

**Characteristics**

- Self-amalgamating
- Fuses to form a homogeneous, cavity-free compound within a short period of time
- Fully removable
- Durable
- Ozone-resistant
- Weatherproof
- Stabilized against UV rays
- No electrolytic corrosion
- Non tacky
- Extremely ductile
- Superior electrical properties
- Excellent adherence to a wide range of substances
- Superior physical properties
- Easy processing

**Application/Suitability**

- Conductor insulation for polymeric insulated cables up to 69 kV
- Padding of cable insulation
- Sealing of casting moulds
- Repairing and connection of various insulating and cable materials e.g. PE, XLPE, EPR, PVC, butyl, neoprene

**Material**

- EPR-Base

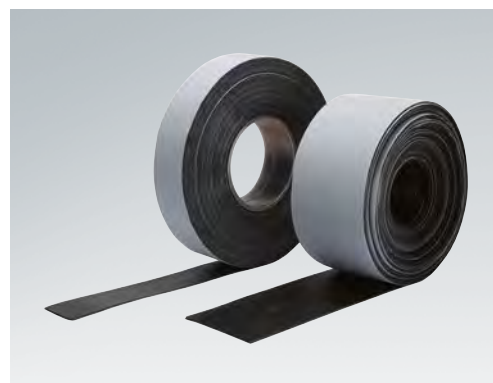
**Colours**

Black

**Scope of delivery**

High voltage insulation tape

Type	Colours	Length m	Width mm	Thickness mm	Art.-No.
No. 60	Black	10	19	0.5	125533
No. 62	Black	10	19	0.75	145908
	Black	5	38	0.75	125584
	Black	10	38	0.75	125589

Technical data	Value
min. elongation at break	900 %
Tensile strength at break	3 MPa
Dielectric constant	2.8
Dissipation factor (50 Hz)	0.0050
Dielectric strength	42 kV/mm
Specific volume resistivity	1 x 10 <sup>13</sup> MΩ
Water absorption	0.05 %
Temperature range	
min.	-40 °C
max.	100 °C



## No. 61 Conductive tape

to control electric fields, self-amalgamating

### Characteristics

- Printed „CAUTION-CONDUCTING TAPE“ to eliminate danger of confusion
- Self-amalgamating
- Fuses to form a homogeneous, cavity-free compound within a short period of time
- Durable
- Ozone-resistant
- No electrolytic corrosion
- Highly flexible
- Superior physical properties

### Application/Suitability

- Repairing of semi-conducting layer in medium voltage cables
- Electrical field smoothing
- For smoothing rough surfaces of connectors and cable lugs

### Material

- EPR-Base



Scope of delivery  
Conductive tape

### Colours



Black

Type	Colours	Length m	Width mm	Thickness mm	Art.-No.
No. 61	Black	4.6	19	0.76	125604
	Black	9.1	19	0.76	125590

Technical data	Value
Elongation at break	900 %
Tensile strength at break	3 MPa
Specific volume resistivity	10 Ω x cm
Temperature range	-40 °C up to 100 °C



## HKB

### Mastic tape

for sealing

#### Characteristics

- Excellent adherence to metal, glass, rubber and plastic
- Superior physical properties
- Superior electrical properties

#### Application/Suitability

- Reinforcement of heat shrinkable sealed areas
- Sealing of cable terminations for Ceander cables

#### Material

- Butyl-/Rubber based



#### Scope of delivery

Mastic tape

#### Colours



Black

Type	Colours	Length m	Width mm	Thickness mm	Art.-No.
HKB	Black	3	20	3	127651

Technical data	Value
Specific volume resistivity	$1 \times 10^{13} \text{ M}\Omega$
Heat resistance	100 °C





## No. 26

### Warning tape

for warning of cable presence in case of excavation work

#### Characteristics

- Printing protected by transparent film
- Durable, elasticity retained at low temperatures
- Colour-fast, luminescent
- Increases the effectiveness of the warning prior to tearing due to 400 % stretchability

#### Application/Suitability

- Warning about the cables located in the ground (in case of excavation work)

#### Note

- Optimal position 40 cm above the feeder

#### Material

- Polyethylene laminated foil



#### Scope of delivery

Warning tape (Tapes and imprints are available in various colours, see order details.)

Note: Other types available on request.

#### Colours



Red/White



Yellow

Type	Colours	Imprint colour: Black	Length m	Width mm	Thickness mm	Art.-No.
No. 26	Red/White	without imprint	500	80	0.08	125583
	Yellow	Achtung Kabel*	250	40	0.15	145862
	Yellow	Achtung Starkstromkabel*	250	40	0.15	145865
	Yellow	Achtung Fernmeldekabel*	250	40	0.15	145864
	Yellow	Achtung Straßenbeleuchtung*	250	40	0.15	145867

\*The imprint on the tape is written in german.

**No. 72****Repair tape**

for repairing damaged cable sheaths, self-amalgamating

**Characteristics**

- Self-amalgamating
- 100 % waterproof
- Superior electrical properties
- High tensile strength

**Application/Suitability**

- Repair of damaged cable sheaths

**Note**

- The use of a repair joint, such as MZ cast resin straight-through joint, is mandatory in case of damage extending beyond the cable sheath to the core insulation, screen or armour.

**Material**

- PIB-Base

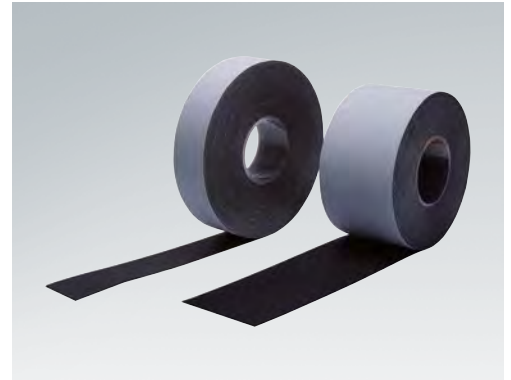
**Scope of delivery**

Repair tape

**Colours**

Black

Type	Colours	Length m	Width mm	Thickness mm	Art.-No.
No. 72	Black	10	25	0.75	125587
	Black	10	50	0.5	125624

Technical data	Value	Tests
min. Elongation at break	600 %	ASTM D 412
Dielectric constant	2.5	ASTM D150
Specific volume resistivity	$1 \times 10^{13} \Omega/\text{cm}$	ASTM D 257
Voltage strength	40 kV/mm	ASTM D 149
Heat resistance	90 °C	



## KRS Repair kit

for repairing damaged cable sheaths, incl. accessories

### Characteristics

- Kit content defined by the praxis

### Note

- See the repair tape „No. 72“ for further information on product properties and technical data

### Application/Suitability

- Repair of damaged cable sheaths

### Note

- The use of a repair joint, such as MZ cast resin straight-through joint, is mandatory in case of damage extending beyond the cable sheath to the core insulation, screen or armour.

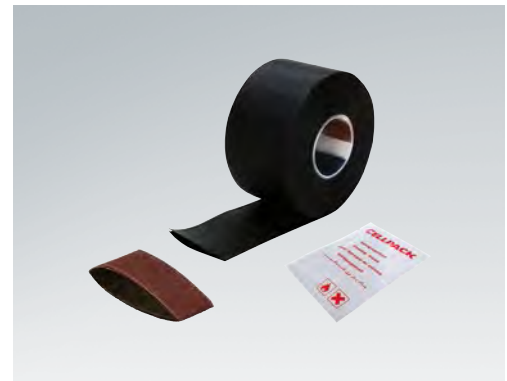

### Scope of delivery

Repair tape No. 72, cleaning tissue, emery cloth, assembly instructions

Type	Art.-No.
KRS 1	145911

**HB****Hot melt adhesive**

for sealing against humidity

**Characteristics**

- Fusible
- Supplied as tape
- Halogen-free

**Application/Suitability**

- Waterproof sealing for heat shrinkable products

**Scope of delivery**



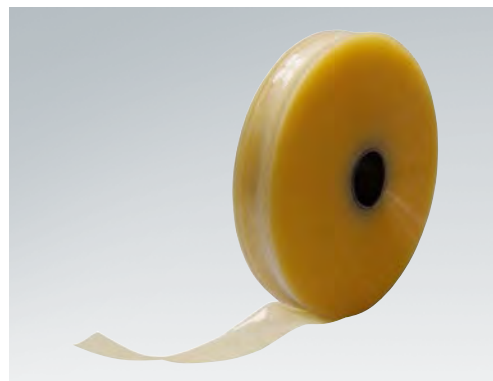

Hot melt adhesive

**Colours**

Transparent

Type	Colours	Length m	Width mm	Thickness mm	Art.-No.
HB	Transparent	50	25	0.25	130837

# ACCESSORIES

	Heating systems .....	246
	Cable ties .....	248
	Tools .....	251
	Chemical products .....	258
	Miscellaneous .....	273



**RB**

**Trace heating system**

self-regulating

**Characteristics**

- VDE certification
- Regulates heat supply temperature according to outdoor temperature
- No danger of over-heating if overlapped
- Economical and operationally safe
- Easy assembly



**Scope of delivery**

1 PU and/or 1 piece

Type	Application	Length m	Art.-No.	
<b>Heating tapes</b>				
<b>RB</b>	10	Heating tape self-regulating	100	249698
	10	Heating tape self-regulating	300	249699
	25	Heating tape self-regulating	100	249700
	25	Heating tape self-regulating	300	249701
<b>Heat shrink accessory system</b>				
<b>RB/SAG1</b>	Connection plate kit	Connection of NYM-/NYY-cables to the heating tape		145882
<b>DB/EAG</b>	Tale off sealing set	Heating tape termination		145874
<b>DB/AG</b>	Heating tape connection kit	Heating tape connection		145873



## DB Heating system

for roofs and gutter

### Characteristics

- VDE certification
- Self-regulating roof and gutter heating system
- Self-regulating heating tapes (no burning danger)
- Low energy costs
- Easy assembly
- Maintenance-free



Scope of delivery  
1 PU and/or 1 piece

Type	Application	Length m	Art.-No.
<b>Heating tapes</b>			
DB 36	Heating tape self-regulating	100	249702
DB 36	Heating tape self-regulating	300	249703
<b>Heat shrink accessory system</b>			
DB/EAG Tale off sealing set	Heating tape termination		145874
DB/AG Heating tape connection kit	Heating tape connection		145873



# KS Cable ties

Standard

### Characteristics

- Smooth, rounded edges for safe and easy handling and assembly
- Internal gearing and rounded-off end to facilitate take-up, insertion and tightening
- Resistant to alkaline earth elements
- Resistant to mould and oil
- Stabilized against UV rays (colour: Black)
- Resistant to dilute acids and alkalis
- Halogen-free
- Flame retardant

### Application/Suitability

- Bundling
- Affixing

### Note

- The lengths are nominal dimensions, minimal deviations are possible.

### Material

- Polyamid 6.6



### Colours



Black

Natural

### Scope of delivery

1 PU cable ties

Type		Colours	Length mm	Width mm	Minimum load N	Quantity	Art.-No.
KS	2.5/98	Natural	98	2.5	80	100	146409
	2.5/98	Black	98	2.5	80	100	146408
KS	2.6/130	Natural	130	2.6	80	100	146454
	2.6/130	Black	130	2.6	80	100	146453
	2.6/200	Natural	200	2.6	80	100	146414
	2.6/200	Black	200	2.6	80	100	146412
KS	3.6/140	Natural	140	3.6	130	100	146419
	3.6/140	Black	140	3.6	130	100	146416
	3.6/200	Natural	200	3.6	130	100	146452
	3.6/200	Black	200	3.6	130	100	146450
	3.6/290	Natural	290	3.6	130	100	146424
	3.6/290	Black	290	3.6	130	100	146422
KS	4.8/200	Natural	200	4.8	220	100	146428
	4.8/200	Black	200	4.8	220	100	146426
	4.8/290	Natural	290	4.8	220	100	146433
	4.8/290	Black	290	4.8	220	100	146431
	4.8/360	Natural	360	4.8	220	100	146435
	4.8/360	Black	360	4.8	220	100	146434
KS	7.8/240	Natural	300	7.8	530	100	146437
	7.8/240	Black	300	7.8	530	100	146436
	7.8/365	Natural	365	7.8	530	100	146440
	7.8/365	Black	365	7.8	530	100	146438
	7.8/750	Natural	750	7.8	530	100	146443
	7.8/750	Black	750	7.8	530	100	146442
KS	9.0/780	Natural	780	9.0	790	100	146449
	9.0/780	Black	780	9.0	790	100	146448
KS	12.6/500	Natural	500	12.6	1100	50	146445
	12.6/500	Black	500	12.6	1100	50	146444
	12.6/850	Natural	850	12.6	1100	50	146447
	12.6/850	Black	850	12.6	1100	50	146446

Technical Data	Value
Working temperature	-10 °C up to 60 °C
Ambient operating temperature after installation	-40 °C up to 80 °C
Dielectric strength	50 kV/mm





## KZB Fastening element

for cable ties

### Characteristics

- Adhesive film to facilitate installation in hard-to-reach areas
- Provides excellent resistance to alkalis, oil, grease, oil products and solvents
- Limited acid resistance
- Resistant to mould and oil
- Self-extinguishing

### Application/Suitability

- Affixing of cable ties
- Prefabrication or subsequent assembly e.g. of office equipment, lifts, motor vehicles and control cubicles

### Material

- Polyamid 6.6

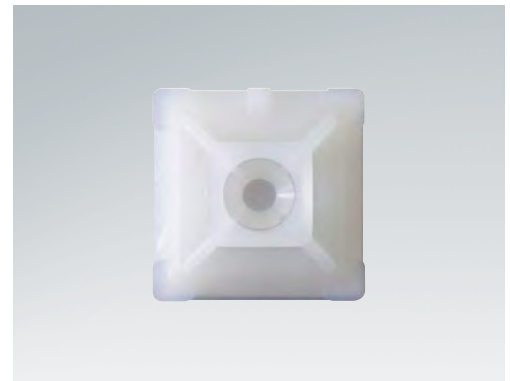

### Scope of delivery

1 PU fastening elements

### Colours



Natural

### Dimensions

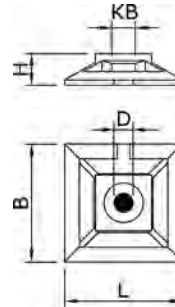

KB = max. width of the cable tie

Type		L m	B mm	D mm	H mm	KB mm	Quantity	Art.-No.
KZB2K	3.6	20	20	3.2	5.3	4	100	146484
	4.8	28	28	4.7	5.8	5	100	146486



# CM Cable marker

for marking cables and conductors

### Characteristics

- Can be labelled
- Moisture-resistant
- Oil-resistant
- Stabilized against UV rays

### Application/Suitability

- Permanent marking for cables and conductors



Scope of delivery  
1 PU cable markers

Type		Length m	Thickness mm	max. Cable-Ø mm	Label area size height x width mm	Art.-No.
CM	10	75	0.08	13	23 x 25	124088
	20	150	0.08	33	23 x 25	124089



## CPB

### Heat shrink torch kit

for installation of heat shrinkable products

#### Characteristics

- User-friendly rotating tube connector
- Gas supply shuts off automatically if burner head is not installed
- Minimal risk of overheating
- Flame extinguishes immediately upon releasing push button
- Continuously adjustable flame
- Bayonet fitting facilitates substitution of burner head
- Quick-starting piezo ignition

#### Application/Suitability

- Suitable for heat shrinkable tubes
- Shrinking of heat shrinkable polyolefine products (caps, sleeves etc.)

#### Caution note

- Warning: Liquid gas is heavier than air. Strictly adhere to safety instructions provided with heat shrink torch kit.



#### Scope of delivery

Wooden case with aluminium profile with components (see order details)

Note: Individual components may also be ordered separately.

Type		Art.-No.
CPB	5 (Set)	146765
	6 (Set)	146766

Type	CPB 5 Set-components	CPB 6 Set-components	Length m	Content ml	Art.-No.
Handle CPB 5/6 with piezo ignition	•	•			146781
Needle point burner (with elbow)	•	•			146782
Heat shrink burner (with elbow)	•	•			146783
Hot-air torch (with elbow)	•	•			146784
Gas tube HD 4.4 R 3/8" li x R 3/8" li	•	•	4		146769
Anti-rupture device for tubing R 3/8" x 3/8" li	•	•			146770
Pressure controller device R 3/8" x 3/8" li	•	•			146780
Pressure controller DIN/Combo 21.8-14 LH x R 3/8 LH	•				123960
Refill connector for small gas bottle, DIN Combo		•			146786
Small gas bottle, refillable		•		400	146785

- included in scope of delivery



## HG 2310 LCD Hot air blower

for installation of heat shrinkable products

### Characteristics

- Easy handling
- Minimal risk of overheating
- Continuously adjustable temperature and air flow

### Application/Suitability

- Most suitable for thin wall heat shrink products made of polyolefin



### Scope of delivery

HG 2310 LCD Hot air blower 2300 W / 230 V

Case

Nozzles (see order details)

Type	Art.-No.
<b>HG 2310 LCD</b> Hot air blower 2300 W / 230 V	123979
<b>Case empty</b> for HG 2310 LCD	123963
<b>Nozzle ST746</b> Soldering reflector	123950
<b>Injector ST708</b> Reduction/20 mm	123952
<b>Injector ST707</b> Reduction/14 mm	123953
<b>Injector ST705</b> Shrinkage reflector	123951



## PZ1

### Mechanical crimping plier

for wire connectors AVS and AVUS

#### Characteristics

- Compact design
- Easy to handle

#### Application/Suitability

- For compression and positive locking of wire connectors AVS and AVUS

#### Scope of delivery

Mechanical crimping plier PZ1



Type	Art.-No.
PZ1 Mechanical crimping plier	124006



## PZ2

### Mechanical crimping plier

for heat shrinkable crimp connectors DR

#### Characteristics

- Universally suitable for 3 different sizes
- Easy to handle

#### Application/Suitability

- For compression and positive locking of heat shrinkable crimp connectors DR



#### Scope of delivery

Mechanical crimping plier PZ2

Type	Art.-No.
PZ2 Mechanical crimping plier	123770



## Counter-holder Assembly help

for screw connectors type CSV and screw cable lugs type CSK

The counter-holder is designed as mounting help for the installation of screw connectors and screw cable lugs with a diameter of 14 to 40 mm.

---

### Scope of delivery

Counter-holder, reduction prism



Type	Art.-No.
Counter-holder	255404



## CP-FLM20 Multi tool

for the preparation of medium voltage cables

The multi tool is designed for cutting and stripping of the outer cable sheaths and the conductor insulation, as well as for removal of cold-strippable semi-conductive layers.

### Characteristics

- Suitable for cables with a diameter of 15 - 50 mm
- For cold-strippable conducting layer thickness of 0.3/0.4 mm or 0.7/0.8 mm
- Adjustable stop and limiting bar
- Cut depth of the insulation and external sheath up to 10 mm
- Suitable for PVC-/PE-/XLPE-insulation
- Adjustable feed motion

### Application/Suitability

- Cutting and stripping of outer sheath
- Controlled initial cutting of cold-strippable semi-conducting layer
- Cutting and stripping of conductor insulation



### Scope of delivery

CP-FLM20: Transport case, multi tool, assembly material, manual instruction

CP-FLM20-S1: Replacement blade

CP-FLM20-S2: Spare blade

Type		Art.-No.
CP-FLM20	Multi tool	250351
CP-FLM20-S1	Replacement blade (for cable sheath)	250355
CP-FLM20-S2	Spare blade (for semiconductor-layer)	250358





## CP-P20 Stripping tool

for the preparation of medium voltage cables

For removal of the co-extruded outer semi-conductive layer.

### Characteristics

- Minimum strip length approx. 30 mm
- Guarantees depth adjustable from 0 - 1.2 mm in 0.1 mm steps
- Maintains high quality of stripped surface
- Hard metal peeling knife
- Operating range 10 - 50 mm
- Predefined rounded corners
- Beginning of stripping at cable end
- Automatic working feed

### Application/Suitability

- Cutting and stripping of co-extruded semi-conducting layer



### Scope of delivery

CP-P20: Stripping tool, assembly instructions

Spare blade

Assembly case

Type	Length mm	Width mm	Height mm	Art.-No.
CP-P20 Stripping tool				250354
Spare blade (for semiconductor-layer)				293710
Assembly case	200	300	90	255897



## UNIVERSAL CLEANER 121 Cleaner

for cleaning and degreasing

### Characteristics

- For use with neoprene, polyethylene, EPR, XLPE, PVC, butyl rubber and thermoplastic insulation
- Protection against accidental discharge
- Cleans and degreases without leaving residue, non-conductive
- Fast-acting, safe
- No degradation

### Application/Suitability

- Cleaning of semi-conducting layers
- Removal of semi-conductive residues (such as graphite)
- Cleaning and degreasing of motors and electrical equipment
- Cleaning of cables and conductors

### Note

- Clean all parts thoroughly. Air dry or wipe with a cloth. Repeat operation as required. Always test a small area prior to cleaning plastics or finished surfaces.



### Colours



Clear

Scope of delivery  
Cleaner

Type	Content l	Drum	Art.-No.
UNIVERSAL CLEANER 121	0.4	Spray	146404
	1	Canister	124026
	5	Canister	124027
	20	Barrel	146405
	200	Barrel	124029

Technical Data	Value
Density	0.62 g/cm <sup>3</sup>
Vapour pressure (at 20 °C)	200.00 hPa
Flash point	-19 °C
Ignition temperature	260 °C
Lower explosion limit in Vol.-%	1.1
Upper explosion limit in Vol.-%	13.0



## ZINC SPRAY 171

### Anti-corrosion spray

for subsequent galvanizing

ZINC SPRAY 171 binds to steel and iron surfaces using an electrochemical process of forming a flexible protection film. This gives the parts an active cathodic protection against corrosion.

#### Characteristics

- Smooth, fine porous film
- With hydrocarbon propellant (flammable)
- Can be varnished
- Can be spot-welded
- Dries quickly
- Unmarked in compliance with ARB material regulations
- No hazard rating in compliance with VBF
- Weatherproof
- Electrically conductive
- Frost-resistant

#### Application/Suitability

- Long-lasting corrosion protection
- Repairing of damaged zinc layers
- Repairing of galvanised surfaces
- Substitute for red lead primer
- Primer for use in auto repair
- Sealing of cavities
- Cold galvanising
- Oxidation protection
- Rust prevention
- Underbody protection



#### Colours



Grey

#### Scope of delivery

Anti-corrosion spray

Type	Content l	Drum	Art.-No.
ZINC SPRAY 171	0.4	Spray	124030

ZINC SPRAY 171 is not approved according to the the food regulations and the construction material norms release 8/76 from the Institute for Construction Technology.

Technical Data	Value
Density	0.95 g/cm <sup>3</sup>
Degree of zinc purity	99 %



## ELECTRO 2-26

### Protective agent

for protection of electrical equipment

#### Characteristics

- Lubricates and permeates

#### Application/Suitability

- Corrosion protection
- Oxidation protection
- Protection against flying sparks
- Protection against leakage current
- Short-circuit protection
- Maintenance and protection of electrical equipment
- Improves drag coefficient
- Expels and provides sealing against moisture



#### Scope of delivery

Protective agent

#### Colours



Transparent

Type	Content l	Drum	Art.-No.
ELECTRO 2-26	0.4	Spray	124045
	5	Canister	124046
	20	Barrel	124047

Technical Data	Value
Density	0.80 g/cm <sup>3</sup>
Flash point	105 °C
Viscosity (cP)	30/40 °C
Dielectric strength	150 kV/mm



## INDUSTRIE 3-36

### Protective agent

for protection of metals

#### Characteristics

- Forms a clear, transparent film
- Lubricates and permeates

#### Application/Suitability

- Dissolves rust
- Release of tightly-sealed components
- Corrosion protection
- Protection of ferrous and non-ferrous metals during storage, processing, and transport
- Moisture protection



#### Scope of delivery

Protective agent

#### Colours



Transparent

Type	Content l	Drum	Art.-No.
INDUSTRIE 3-36	0.4	Spray	124014
	5	Canister	124015
	20	Barrel	124016
	200	Barrel	124013

Technical Data	Value
Density	0.81 g/cm <sup>3</sup>
Flash point	105 °C
Viscosity (cP)	30/40 °C
Dielectric strength	180 kV/mm

**URETHAN****Protective insulating varnish**

for protection against chemical exposure

**Characteristics**

- Highly resistant

**Application/Suitability**

- Corrosion protection
- Moisture protection
- Protection of appliances and materials against chemical exposure
- Protective coating for electric motors, transformers, components and appliances

**Scope of delivery**

Protective insulating varnish

**Colours**

Transparent

Type	Content l	Drum	Art.-No.
URETHAN	Transparent	Spray	124017
	Transparent	Canister	124018

Technical Data	Value
Density	0.79 g/cm <sup>3</sup>
Drying time	25-30 minutes
Flash point	-97 °C
Dielectric strength	82.9 kV/mm



## CONTACT CLEANER

### Cleaning spray

for cleaning of electro technical equipment

#### Characteristics

- Does not damage plastic, rubber or varnished surfaces
- Neutral
- Fast evaporating

#### Application/Suitability

- Removal of light dirt such as dust, fibres, thin oil films, moisture or residues caused by fingerprints
- Cleaning of sensitive electrical equipment



#### Scope of delivery

Cleaning spray

#### Colours



Transparent

Type	Content l	Drum	Art.-No.
CONTACT CLEANER	0.4	Spray	124024

Technical Data	Value
Density	0.64 g/cm <sup>3</sup>
Drying time	15 minutes

**PLASTIC****Clear varnish**

for insulation and sealing

**Characteristics**

- Can be soldered through
- Does not drip
- Highly resistant

**Application/Suitability**

- Sealing
- Elimination or prevention of current leakage, corona discharges, soft short circuits
- Insulation of panel boards, components, wires and cables
- Protective film against pollutants such as acid, alkali, alcohol and moisture
- Sealing of board, wood, leather

**Scope of delivery**

Clear varnish

**Colours**

Transparent

Type	Content l	Drum	Art.-No.
PLASTIC	0.4	Spray	124049

Technical Data	Value
Density	0.78 g/cm <sup>3</sup>
Flash point	-97 °C
Drying time	20 minutes
Dielectric strength	21 kV/mm
Heat resistance	-70 °C up to 120 °C





## SILICON

### Insulating and lubricating oil spray

water repellent, prevents from flashover

#### Characteristics

- Does not damage rubber, plastics, textiles or varnished surfaces
- Does not damage construction materials
- Does not dry out
- Non-adherent
- Suitable for use as moisture buffer
- Water-resistant

#### Application/Suitability

- Elimination or prevention of current leakage, corona discharges, soft short circuits
- Wire feed lubricant
- Insulating
- Protection of high-voltage equipment and tube sockets against flying sparks
- Short-circuit protection
- Can be used as a separating agent for plastics
- Prevents treated components from sticking together



#### Colours



Transparent

#### Scope of delivery

Insulating and lubricating oil spray

Type	Content	Drum	Art.-No.
SILICON	0.4	Spray	124032

Technical Data	Value
Density	0.55 g/cm <sup>3</sup>
Flash point	-97 °C
Viscosity (cP)	1000/20 °C
Dielectric strength	12 kV/mm
Heat resistance	-50 °C up to 200 °C



## CABLE GLISS

### Lubricant spray

for feeding cables and conductors

#### Characteristics

- Does not damage rubber, plastics, textiles or varnished surfaces
- Does not damage construction materials
- Does not dry out
- Non-adherent
- Suitable for use as moisture buffer
- Water-resistant

#### Application/Suitability

- Feeding of cables and wires through electrical installation conduits



#### Scope of delivery

Lubricant spray

#### Colours



Transparent

Type	Content	Drum	Art.-No.
CABLE GLISS	0.4	Spray	124050

Technical Data	Value
Density	0.63 g/cm <sup>3</sup>
Viscosity (cP)	1000/20 °C
Dielectric strength	12 kV/mm
Heat resistance	-50 °C up to 200 °C



## EASY-GLIDE

### Lubricant

for feeding cables and conductors

EASY-GLIDE simplifies and accelerates the pulling and laying of cables and wires in electric conduits and channels. Damage to cables and cable sheaths is prevented.

#### Characteristics

- Available in light, practical plastic bottle or in handy bucket
- Pleasant smell
- Harmless ingredients
- Biologically degradable
- Non-corrosive
- Superior lubricating properties
- Non-adherent and does not leave stains
- Does not cause skin irritation, easily washable
- Can be used with bare hands
- Non-flammable
- Silicone free
- Teflon free

#### Application/Suitability

- Lubricant for feeding cables and conductors through electrical installation conduits

#### Storage conditions/Shelf life

- Unlimited shelf life



#### Scope of delivery

Lubricant

Type	Content	Drum	Art.-No.
EASY-GLIDE	250 ml	0.25	Plastic bottle
	1050 ml	1.05	Plastic bottle
	5000 ml	5	Bucket



# DUSTER Cleaning spray

for not readily accessible areas

### Characteristics

- Self-cleaning
- Newly-developed materials
- With high yield
- Chemically clean
- Evaporates immediately
- Does not corrode materials
- Develops high pressure
- Leaves no traces

### Application/Suitability

- Cleaning of areas with limited accessibility
- Proven track record in photo, optic, watch, precision and electronic industries



### Scope of delivery

Cleaning spray

### Colours



Transparent

Type	Content l	Drum	Art.-No.
DUSTER	0.4	Spray	124051

Technical Data	Value
Density	0.55 g/cm <sup>3</sup>



# MINUS

## Cooling spray

for thermal fault diagnosis

### Characteristics

- Cools down to -50 °C
- Does not damage construction materials
- Immediate evaporation leaving no residue
- Fast and reliable

### Application/Suitability

- Thermal fault detection
- Prevention of overheating during soldering
- Cooling of heat-sensitive components
- Effective overriding of thermal switches and thermostats etc.



### Scope of delivery

Cooling spray

### Colours



Transparent

Type	Content	Drum	Art.-No.
MINUS	0.4	Spray	124044

Technical Data	Value
Density	0.55 g/cm <sup>3</sup>



# MULTI Multi-function oil spray

for protection and cleaning

### Characteristics

- For cleaning
- Does not damage rubber, plastics, textiles or varnished surfaces
- Dissolves rust
- Protects and lubricates
- Eliminates squeaking
- Water-repellent

### Application/Suitability

- Hobbies/home/garden
- Industry and workshops
- Start-up aid for wet motors



### Scope of delivery

Multi-function oil spray

### Colours



Light brown

Type	Content l	Drum	Art.-No.
MULTI	0.4	Spray	124043

Technical Data	Value
Density	0.78 g/cm <sup>3</sup>
Viscosity (cP)	30/40 °C



# Silicone grease Lubricating grease

for lubrication/greasing

### Characteristics

- Glides well
- Non-toxic

### Application/Suitability

- Lubricant paste

Scope of delivery  
Lubricating grease



### Colours



Transparent

Type	Content g	Art.-No.
Silicone grease	90	124055



## EASY-CLEAN Hand wipes

for universal cleaning

Most effective cleaning effect is achieved with the aid of the combination of patented liquid formula and durable, roughened cloth surface. This enables removing of heavy fat stains, tar, oil, copper paste, brake and coal dust, varnish and paints, inks, grass stains and many other stains.

### Characteristics

- Heavy-duty one-step cleaning system
- Easily removes even the toughest stains
- Retains dirt without leaving traces
- Quick-drying cleaning solution with moisturising effect
- Biodegradable wipes
- Antibacterial
- Free from harmful substances
- Non-toxic
- Non-irritant
- Contains moisturising substances

### Application/Suitability

- In order to remove ingrained dirt, apply the darker side of the cloth. Let it soak in, then rub off. If the stain has not come out, let it soak longer.
- Remove most of the dirt using the darker textured side of the cloth, then polish with the soft side to achieve a completely clean residue-free finish.
- Skin may feel slightly sticky after use due to moisturising emulsion, as absorption time varies according to skin types.

### Storage conditions/Shelf life

- Unlimited shelf life



### Scope of delivery

Hand wipes

Note: The hand cleaning wipes are packed individually in the sales display.

Type		Content pieces	Art.-No.
EASY-CLEAN	Plastic dispenser	72	264705
	Sales display	40	265196



**RF****Pressure spring**

for permanently elastic contact

**Characteristics**

- Corrosion-resistant
- Fatigue-proof
- Guarantees consistent radial contact stress

**Application/Suitability**

- For cast resin, heat shrinkable and slip-on cable accessories
- Enables solder-free electrical connection of metal cable components (screen, armouring, metal sheath) and earthing elements (copper grounding wire, cooper mesh joint etc.)

**Note**

- Pressure springs are no current-carrying parts.

**Material**

- Special stainless steel

**Colours**

Brass

**Scope of delivery**

Pressure spring

Type	Width mm	Cable-Ø mm	Outer-Ø mm	Art.-No.
RF	0	16	6 - 10	126293
	0.5	16	9 - 14	126294
	1	16	13 - 22	126295
	2	16	17 - 28	126296
	3	16	24 - 37	126297
	4	16	33 - 49	126298
	5	20	44 - 70	126299
6	20	55 - 92	126300	

## LG

**Putty/sealing compound**

for sealing of wall ducts

**Characteristics**

- Two-component PUR cast resin
- In practical and easy-to-use two-chamber bags
- Mechanically removable
- Halogen-free
- Not harmful to the environment
- Gas-tight and waterproof up to 1.5 bar
- Flexible after hardening
- Superior adhesion to metal, plastics (PVC, XLPE and PE), concrete, artificial and natural stone
- Superior thermodynamic properties

**Application/Suitability**

- Outdoor
- Indoor
- Underground
- Water
- Sealing of wall ducts

**Storage conditions/Shelf life**

- In aluminium bag 18 months at ambient temperatures between 15 °C and 35 °C

**Scope of delivery**

Putty/sealing compound, spatula, assembly instructions

Optional accessory: Cable centring aid KZ (see Accessories)  
Cleaner UNIVERSAL CLEANER 121 (see Accessories)

Note: Other sizes available on request.

Type		Content ml	Art.-No.
LG	250	250	125198
	500	500	125199

Technical Data	Value
Density	1.10 g/cm <sup>3</sup>
Hardness	80 Shore A
Reactant	
Flash point in open cup min.	200 °C
Cast resin component	
Flash point in open cup min.	200 °C
Reaction temperature	60 °C
Processing time (pot life) 250 ml mixture	
20 °C	15 minutes
35 °C	9 minutes

**KZ****Cable centring aid**

for putty/sealing compound, reduces the required volume

**Characteristics**

- Flexible
- Individually adjustable

**Application/Suitability**

- Centring of cables in wall ducts

**Material**

- Polyethylene foam

**Scope of delivery**

Cable centring aid

Type	Length m	Thickness mm	Art.-No.
KZ	20	1	143490
	30	1	143491
	40	1	143492

## DUCT SEAL

### Universal sealing compound

based on butyl rubber

#### Characteristics

- Firm consistency, good shape retention, can be easily moulded
- Excellent adhesion to almost all materials (metal, concrete, stone, wood, glass, ceramic, enamel etc.)
- Plastic viscosity
- Superior ageing resistance
- High resistance to gases
- High resistance to condensates
- Stabilized against UV rays
- Not harmful to the environment
- High water resistance
- Easy processing

#### Application/Suitability

- Sealing of wall ducts, cable ducts, electrical devices, drains and sanitary installations



#### Colours



Grey

#### Scope of delivery

Universal sealing compound

Optional accessory: Cleaner UNIVERSAL CLEANER 121 (see Accessories)

Type		Art.-No.
DUCT SEAL	0.454 kg	240358
	2.5 kg	240357

Technical Data	Value
Short-term heat resistance	120 °C
Long-term heat resistance	
min.	-40 °C
max.	100 °C

**LW****Splice cassette system**

for fibre optic cables

**Characteristics**

- Flange mount strain relief for fibre optic cables
- Insertion opening for up to max. 12 glass fibres
- Flame-retardant plastic housing
- All current splice holders are interlockable (with anti-rotation protection)
- Easy attachment of stranded conductors
- Counter support bracket for easy insertion of glass fibres
- The conductors can be easily redirected to other levels
- Halogen-free
- Mechanical strain relief

**Application/Suitability**

- Where high performance fibre optic cabling and connections are required
- Compact joints
- Coupler housing for joints or trays
- Mechanical protection for spliced optical fibres
- Drawer application (modular compartments), choice of stress relief bushing for easy assembly of pigtail
- Vertical compartments for multi-functionality and flexibility

**Note**

- Recommended operating temperature range of -55 to +70 °C

**Material**

- Ethyl vinyl acetate insert
- Flexible heat shrinkable tube
- Stainless steel bar

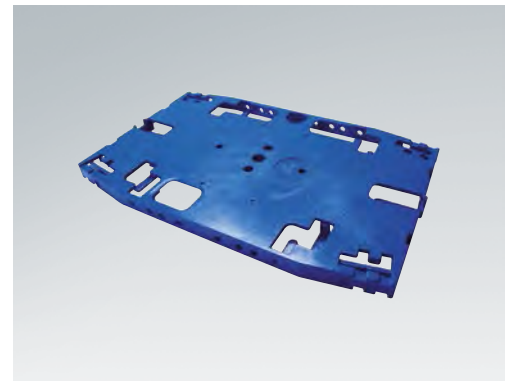
**Scope of delivery**

1 PU

Type	Colours	Piece	Art.-No.
<b>LWK</b> Splice cassette	Blue	25	146694
<b>LWD</b> Cover	Transparent	25	126505
<b>Strain reliefs</b>			
<b>LZW-R</b> Strain relief right	Blue	25	126498
<b>LZW-L</b> Strain relief left	Blue	25	126497
<b>Splice holders</b>			
<b>LWH-S</b> Splice holder shrink protection	Transparent	25	126506
<b>LWH-L</b> Splice holder 6 x shrink	Transparent	25	126499
<b>Splice protection</b>			
<b>LHS</b> Shrink splice protection	Transparent	50	146706

## AZK Branch clamp

for sealing of multiple cable entry points

### Characteristics

- With hot melt adhesive
- Dimensionally stable

### Application/Suitability

- Sealing of multiple cable entry points in heat shrinkable repair sleeves and tubes



### Scope of delivery

Branch clamp

Type	Length mm	Width mm	Art.-No.
AZK small	64	28	123982
AZK big	110	60	143744

## SVL Shield continuity wire

for telecommunication cables

### Characteristics

- High flexibility

### Application/Suitability

- Connection and branching of aluminium-clad cable sheath
- For two or more telecommunication cables



### Scope of delivery

Shield continuity wire

Type	Length mm	Art.-No.
230	230	143314
300	300	143318
350	350	143319
400	400	143320
450	450	143317
500	500	143321

## SAS Branching kit

for telecommunication cables

### Characteristics

- With clamp connectors
- High flexibility

### Application/Suitability

- Connecting and branching of aluminium-clad cable sheath
- For two or more telecommunication cables



### Scope of delivery

Branch terminal, shield continuity wire with clamps

Type	Length mm	Art.-No.
SAS 120	120	190760



# INDEX

Index: of article numbers ..... 282

Index: of article designations..... 289

Index: of product families..... 290

<b>123...</b>	124685.....100	125872.....202	126087.....204	126260.....203
123770.....254	124730.....97	125875.....202	126089.....204	126261.....203
123950.....252	124763.....97	125876.....202	126091.....204	126264.....203
123951.....252	124786.....87	125877.....202	126093.....204	126265.....203
123952.....252	124787.....87	125878.....202	126094.....204	126266.....203
123953.....252	124788.....87	125879.....202	126096.....204	126267.....203
123960.....251	124789.....87	125888.....200	126098.....204	126293.....273
123963.....252	124790.....87	125889.....200	126099.....204	126294.....273
123979.....252	124815.....87	125890.....200	126102.....204	126295.....273
123982.....278	124861.....86	125891.....200	126105.....205	126296.....273
	124865.....86	125892.....200	126106.....205	126297.....273
<b>124...</b>	124901.....102	125895.....198	126134.....205	126298.....273
124006.....253	124909.....102	125897.....199	126135.....205	126299.....273
124013.....261	124962.....102	125898.....199	126136.....205	126300.....273
124014.....261	124986.....102	125899.....199	126137.....205	126301.....218
124015.....261	124989.....102	125900.....199	126138.....205	126302.....218
124016.....261	124990.....102	125901.....199	126164.....214	126303.....237
124017.....262	124991.....102	125902.....199	126165.....214	126313.....237
124018.....262	124992.....102	125903.....199	126169.....214	126315.....237
124024.....263		125904.....199	126170.....214	126316.....237
124026.....258	<b>125...</b>	125905.....199	126172.....214	126497.....277
124027.....258	125153.....106	125906.....199	126179.....213	126498.....277
124029.....258	125154.....106	125907.....199	126180.....213	126499.....277
124030.....259	125155.....106	125909.....211	126181.....213	126505.....277
124032.....265	125165.....105	125914.....217	126182.....213	126506.....277
124043.....270	125166.....105	125915.....217	126183.....213	126665.....14
124044.....269	125167.....105	125916.....217	126184.....213	126672.....18
124045.....260	125198.....274	125947.....200	126185.....213	126674.....18
124046.....260	125199.....274	125948.....200	126186.....213	126675.....18
124047.....260	125202.....112	125950.....198	126187.....213	126676.....18
124049.....264	125203.....112	125951.....198	126188.....213	126696.....24
124050.....266	125204.....112	125952.....198	126189.....213	126697.....24
124051.....268	125205.....112	125953.....198	126190.....213	126698.....24
124055.....271	125206.....112	125954.....198	126191.....213	126713.....24
124088.....250	125207.....112	125955.....198	126192.....213	126714.....24
124089.....250	125208.....112	125956.....198	126193.....213	126715.....24
124169.....80	125209.....112	125957.....198	126194.....210	126716.....24
124170.....80	125286.....108	125958.....198	126195.....210	126717.....24
124171.....80	125287.....108	125959.....198	126196.....210	126719.....26
124172.....80	125288.....108	125960.....198	126197.....210	126720.....26
124173.....80	125289.....108	125961.....198	126199.....210	126721.....26
124174.....80	125290.....108	125962.....198	126200.....210	126740.....26
124175.....80	125291.....108	125963.....198	126201.....210	126745.....14
124176.....80	125334.....69	125964.....198	126202.....210	126769.....25
124293.....78, 79	125335.....69	125965.....198	126204.....210	126770.....25
124294.....78, 79	125336.....69	125966.....199	126205.....210	126771.....25
124295.....78, 79	125337.....69	125967.....198	126206.....210	126773.....25
124296.....78, 79	125338.....69		126207.....210	126797.....40
124297.....78, 79	125339.....69	<b>126...</b>	126208.....210	126798.....40
124298.....78	125345.....69	126040.....204	126209.....210	126799.....40
124299.....78	125351.....69	126044.....204	126211.....210	126803.....40
124300.....78	125365.....71	126046.....204	126214.....214	126804.....40
124308.....78	125371.....71	126048.....204	126216.....215	126805.....40
124309.....78	125373.....71	126051.....204	126242.....203	126806.....40
124318.....126	125374.....71	126052.....204	126243.....203	126807.....40
124319.....126	125475.....233	126054.....204	126245.....203	126808.....40
124320.....126	125476.....233	126055.....204	126246.....203	126809.....40
124505.....82	125483.....233	126059.....204	126247.....203	126810.....40
124506.....82	125533.....238	126060.....204	126248.....203	126811.....40
124507.....77	125583.....241	126064.....204	126249.....203	126821.....37
124508.....77	125584.....238	126065.....204	126250.....203	126822.....38
124510.....82	125587.....242	126070.....204	126251.....203	126823.....38
124511.....82	125589.....238	126072.....204	126252.....203	126824.....38
124513.....82	125590.....239	126074.....204	126253.....203	126832.....38
124516.....83	125591.....234	126077.....204	126254.....203	126847.....39
124517.....83	125604.....239	126080.....204	126255.....203	126854.....39
124518.....83	125624.....242	126082.....204	126258.....203	126855.....39
124683.....99	125870.....202	126085.....204	126259.....203	126856.....39

126857	39	127082	54	127202	47	127698	90	<b>133...</b>	
126891	46	127083	54	127203	47	127699	90	133024	93, 94
126899	46	127084	53	127204	47	127700	90	133841	97
126907	46	127085	53	127205	47	127701	90	<b>134...</b>	
126916	46	127086	53	127206	47	127703	90	134999	102
126924	46	127087	54	127207	47	127705	84	<b>135...</b>	
126932	46	127088	54	127208	47	127706	84	135533	108
126940	46	127089	53	127209	47	127707	84	135534	106
126945	46	127090	54	127210	47	127708	84	135859	62
126950	46	127091	54	127211	47	127709	90	135860	65
126954	46	127092	53	127212	47	127733	90	<b>137...</b>	
126960	46	127093	53	127213	47	127763	90	137358	110
126961	46	127094	53	127214	47	<b>130...</b>		137406	110
126969	46	127095	54	127215	47	130519	233	137712	110
126977	50	127096	54	127216	47	130615	233	137877	110
126990	50	127097	55	127217	47	130618	233	<b>138...</b>	
126995	50	127098	56	127218	47	130619	233	138162	110
<b>127...</b>		127099	55	127225	48	130622	233	<b>139...</b>	
127000	50	127100	55	127226	48	130624	233	139163	110
127005	50	127101	55	127227	48	130626	233	<b>143...</b>	
127010	50	127102	56	127228	48	130629	233	143314	279
127015	50	127104	55	127229	48	130629	233	143317	279
127020	53	127106	55	127230	48	130630	233	143318	279
127021	54	127107	55	127242	50	130652	233	143319	279
127027	53	127108	55	127383	62	130654	233	143320	279
127034	53	127109	56	127384	62	130655	233	143321	279
127041	53	127110	56	127386	62	130656	233	143490	275
127042	54	127111	55	127387	62	130660	233	143491	275
127043	54	127112	56	127391	62	130662	233	143492	275
127044	53	127113	55	127394	62	130664	233	143502	219
127045	53	127114	55	127397	62	130665	233	143503	219
127046	53	127115	55	127400	62	130666	233	143505	219
127047	54	127116	56	127403	62	130667	233	143506	219
127048	54	127117	56	127406	62	130668	233	143508	219
127049	53	127118	55	127407	62	130675	233	143509	219
127050	54	127119	56	127408	62	130837	244	143536	69
127051	54	127120	55	127416	62	130945	16	143537	69
127052	53	127121	55	127417	62	<b>131...</b>		143539	69
127053	53	127122	55	127418	62	131045	212	143540	69
127054	53	127123	56	127421	62	131047	212	143556	71
127055	54	127125	55	127422	62	131048	212	143563	71
127056	54	127126	56	127423	62	131049	212	143592	73
127057	53	127127	55	127425	62	131090	212	143595	73
127058	54	127128	55	127427	62	131100	38	143601	73
127059	54	127129	55	127429	62	131118	97	143605	73
127060	53	127130	56	127471	60	131119	97	143627	73
127061	53	127131	56	127472	60	131123	97	143628	73
127062	53	127132	55	127473	60	131126	97	143629	73
127063	54	127133	56	127474	60	131149	93, 94	143630	73
127064	54	127134	55	127475	60	131151	93, 94	143632	73
127065	53	127135	55	127476	60	131233	106	143637	73
127066	54	127136	55	127477	60	131331	108	143646	73
127067	54	127137	56	127487	65	131778	93, 94	143647	73
127068	53	127138	56	127488	65	131854	93, 94	143648	73
127069	53	127139	55	127490	65	131855	93, 94	143649	73
127070	53	127140	56	127493	65	131863	81	143650	73
127071	54	127141	55	127494	65	131864	81	143654	73
127072	54	127142	55	127503	65	131865	81	143659	73
127073	53	127143	55	127505	65	131866	81	143661	73
127074	54	127144	56	127507	65	131867	81	143663	73
127075	54	127145	56	127510	65	131998	37	143665	73
127076	53	127189	46	127511	65	131999	37	143669	73
127077	53	127190	46	127515	65	<b>132...</b>			
127078	53	127191	46	127522	65	132206	102		
127078	53	127192	46	127651	240	132464	194		
127079	54	127193	46	127695	90				
127080	54	127194	46	127696	90				
127081	53	127201	46	127697	90				

143670.....73	144345.....46	144444.....54	145127.....44	145489.....15
143671.....73	144347.....47	144445.....54	145128.....44	145493.....15
143672.....73	144348.....47	144446.....54	145129.....44	145496.....15
143673.....73	144349.....48	144448.....54	145130.....44	145541.....15
143679.....73	144350.....48	144449.....54	145131.....44	145552.....17
143680.....73	144362.....50	144450.....54	145132.....57	145559.....20
143744.....278	144363.....51	144451.....54	145135.....57	145560.....20
143759.....62	144366.....51	144454.....54	145137.....57	145561.....21
143764.....62	144367.....51	144455.....54	145142.....57	145562.....21
143766.....62	144368.....50	144456.....54	145150.....57	145564.....20
143770.....62	144369.....51	144457.....54	145157.....57	145565.....21
143803.....62	144371.....50	144459.....54	145165.....57	145566.....21
143806.....62	144372.....50	144460.....54	145173.....57	145568.....20
143811.....62	144374.....51	144461.....54	145181.....57	145569.....20
143818.....62	144375.....51	144462.....56	145189.....57	145570.....21
<b>144...</b>	144378.....50	144464.....56	145239.....16	145571.....21
144013.....62	144379.....51	144493.....64	145243.....16	145572.....20
144018.....62	144381.....50	144498.....64	145246.....14	145573.....21
144255.....47	144382.....50	144527.....67	145249.....14	145574.....20
144262.....48	144383.....51	144536.....67	145255.....14	145575.....20
144263.....48	144384.....51	144545.....67	145257.....14	145576.....21
144267.....47	144385.....50	144559.....67	145266.....14	145577.....20
144275.....48	144386.....51	144596.....65	145267.....14	145578.....22
144279.....47	144388.....50	144613.....65	145270.....14	145600.....42
144286.....48	144389.....50	144620.....65	145273.....14	145604.....42
144287.....48	144390.....51	144863.....65	145282.....14	145611.....42
144288.....46	144391.....51	144876.....194	145295.....14	145614.....42
144290.....48	144392.....50	144878.....194	145296.....14	145616.....42
144291.....47	144393.....51	144880.....194	145320.....14	145622.....216
144292.....47	144395.....50	144882.....194	145332.....14	145624.....216
144294.....47	144396.....50	144884.....194	145338.....14	145626.....217
144295.....47	144397.....51	144886.....194	145342.....14	145627.....217
144298.....48	144398.....51	144888.....194	145354.....28	145628.....217
144299.....48	144399.....50	144892.....194	145362.....13	145628.....217
144300.....46	144400.....51	144898.....194	145363.....13	145630.....124
144301.....47	144401.....50	144921.....194	145386.....30	145633.....124
144302.....47	144402.....50	144935.....194	145387.....31	145635.....19
144304.....47	144403.....51	144943.....194	145388.....30	145655.....19
144305.....47	144404.....51	<b>145...</b>	145391.....30	145656.....19
144308.....46	144405.....51	145064.....60	145396.....32	145657.....19
144309.....48	144406.....50	145065.....60	145397.....32	145659.....19
144310.....47	144407.....51	145069.....60	145398.....32	145660.....19
144312.....47	144408.....50	145071.....60	145400.....35	145661.....19
144313.....47	144409.....50	145077.....60	145401.....35	145665.....19
144315.....46	144410.....51	145073.....60	145402.....36	145666.....19
144316.....48	144411.....51	145075.....60	145403.....36	145667.....19
144317.....47	144412.....51	145093.....41	145405.....36	145668.....19
144319.....47	144413.....50	145096.....41	145406.....36	145669.....19
144320.....47	144414.....51	145097.....41	145407.....36	145670.....19
144322.....46	144415.....50	145102.....44	145408.....36	145671.....19
144323.....47	144416.....50	145103.....44	145434.....34	145680.....19
144324.....46	144417.....51	145104.....44	145435.....34	145681.....19
144326.....47	144418.....51	145105.....44	145436.....33	145682.....19
144327.....47	144419.....51	145106.....44	145438.....34	145771.....232
144328.....46	144420.....58	145107.....44	145439.....33	145772.....232
144329.....47	144426.....54	145108.....44	145443.....34	145773.....232
144330.....46	144428.....54	145111.....44	145444.....33	145774.....232
144332.....47	144429.....54	145115.....44	145448.....34	145775.....232
144333.....47	144430.....54	145116.....44	145449.....33	145776.....232
144334.....46	144431.....54	145118.....44	145458.....127	145777.....232
144335.....47	144433.....54	145119.....44	145461.....127	145778.....232
144336.....46	144434.....54	145120.....44	145464.....127	145779.....232
144338.....47	144435.....54	145121.....44	145479.....17	145780.....232
144339.....47	144437.....54	145122.....44	145481.....17	145781.....232
144340.....48	144438.....54	145123.....44	145482.....17	145782.....232
144343.....48	144439.....54	145124.....44	145483.....17	145783.....232
144344.....47	144440.....54	145125.....44	145484.....17	145784.....232
	144443.....54	145126.....44	145486.....15	145785.....232

145786.....232	145991.....236	146419.....248	150826.....28	171762.....166
145787.....232	145994.....236	146422.....248		171763.....166
145788.....232	145997.....236	146424.....248	<b><u>151...</u></b>	171791.....127
145789.....232		146426.....248	151500.....14	
145790.....232	<b><u>146...</u></b>	146428.....248		<b><u>173...</u></b>
145791.....232	146012.....235	146431.....248	<b><u>152...</u></b>	173132.....167
145792.....232	146016.....235	146433.....248	152008.....60	173134.....167
145793.....232	146018.....235	146434.....248	152509.....18	
145794.....232	146020.....235	146435.....248	152520.....18	<b><u>174...</u></b>
145795.....232	146024.....235	146436.....248	152521.....18	174183.....16
145796.....232	146028.....235	146437.....248	152522.....18	
145797.....232	146030.....235	146438.....248	152523.....18	<b><u>176...</u></b>
145798.....232	146032.....235	146440.....248	152932.....97	176369.....205
145799.....232	146034.....235	146442.....248		
145800.....232	146036.....235	146443.....248	<b><u>153...</u></b>	<b><u>180...</u></b>
145801.....232	146038.....235	146444.....248	153392.....21	180231.....36
145802.....232	146040.....235	146445.....248		180522.....167
145803.....232	146044.....235	146446.....248	<b><u>154...</u></b>	180739.....24
145804.....232	146046.....235	146447.....248	154613.....51	180760.....24
145805.....232	146048.....235	146448.....248	154637.....35	180761.....25
145806.....231	146050.....235	146449.....248	154982.....41	180762.....40
145807.....231	146052.....235	146450.....248		
145808.....231	146054.....235	146452.....248	<b><u>155...</u></b>	<b><u>181...</u></b>
145809.....231	146056.....235	146453.....248	155962.....60	181014.....86
145810.....231	146058.....235	146454.....248		
145811.....231	146060.....236	146484.....249	<b><u>156...</u></b>	<b><u>182...</u></b>
145812.....231	146064.....236	146486.....249	156847.....64	182390.....128
145813.....231	146066.....236	146694.....277		182731.....167
145814.....231	146068.....236	146706.....277	<b><u>157...</u></b>	182732.....167
145815.....231	146072.....236	146765.....251	157645.....97	182733.....167
145816.....231	146107.....236	146766.....251		182734.....167
145817.....231	146109.....236	146769.....251	<b><u>158...</u></b>	182735.....170
145819.....233	146111.....236	146770.....251	158903.....65	182736.....170
145820.....233	146113.....236	146780.....251		182737.....170
145821.....231	146115.....236	146781.....251	<b><u>159...</u></b>	182738.....170
145822.....231	146119.....236	146782.....251	159667.....205	
145823.....231	146123.....68	146783.....251	159670.....205	
145824.....231	146124.....68	146784.....251		<b><u>184...</u></b>
145825.....231	146158.....166	146785.....251		184472.....170
145826.....231	146159.....166	146786.....251	<b><u>163...</u></b>	184796.....167
145827.....231	146160.....166		163053.....110	184797.....167
145828.....231	146216.....166	<b><u>147...</u></b>	163952.....17	184798.....167
145829.....231	146217.....166	147217.....216		184799.....167
145830.....231	146218.....166	147533.....97	<b><u>165...</u></b>	184800.....167
145831.....231	146220.....169		165612.....41	184801.....167
145832.....231	146222.....169	<b><u>148...</u></b>	165912.....73	184802.....167
145862.....241	146224.....169	148152.....128		184803.....167
145864.....241	146226.....169	148153.....128	<b><u>166...</u></b>	184805.....170
145865.....241	146228.....166	148168.....35	166012.....73	184806.....170
145867.....241	146234.....169	148432.....205	166013.....73	184807.....170
145873.....246, 247	146235.....169	148840.....60	166016.....73	184808.....170
145874.....246, 247	146242.....169	148842.....60	166373.....214	184809.....170
145882.....246	146296.....169	148844.....71	166374.....199	184811.....170
145908.....238	146297.....166	148876.....110	166972.....71	184812.....170
145911.....243	146298.....169		166973.....71	184813.....170
145938.....235	146300.....166	<b><u>149...</u></b>		184815.....170
145941.....235	146301.....166	149433.....60	<b><u>169...</u></b>	184816.....170
145945.....235	146302.....166		169180.....48	
145948.....235	146303.....169	<b><u>150...</u></b>	169406.....80	<b><u>186...</u></b>
145951.....235	146304.....169	150148.....60	169471.....71	186615.....71
145954.....235	146306.....169	150149.....60	169473.....71	
145957.....235	146404.....258	150154.....14	169475.....71	<b><u>189...</u></b>
145961.....235	146405.....258	150158.....14	169477.....71	189738.....199
145964.....235	146408.....248	150160.....14	169711.....71	
145967.....235	146409.....248	150161.....14		<b><u>190...</u></b>
145970.....235	146412.....248	150162.....14	<b><u>171...</u></b>	190195.....86
145973.....235	146414.....248	150278.....60	171756.....169	190760.....280
145988.....236	146416.....248	150825.....28	171757.....169	
			171761.....166	

<b>193...</b>	194086.....133	197536.....187	197665.....183	<b>201...</b>
193339.....133	194087.....133	197537.....186	197666.....183	201374.....164
193370.....133	194088.....133	197538.....186	197667.....183	201375.....164
193372.....141	194089.....133	197539.....186	197668.....184	201377.....164
193374.....141	194090.....133	197543.....188	197669.....184	201379.....164
193414.....137	194091.....133	197544.....188	197670.....184	201381.....164
193415.....36	194092.....133	197545.....188	197671.....184	201382.....164
193416.....137	194093.....133	197546.....188	197672.....184	201385.....134
193442.....59	194094.....133	197547.....188	197673.....184	201386.....134
193644.....209	194293.....163	197548.....188	197674.....184	201388.....134
	194294.....163	197555.....189	197675.....184	201393.....134
<b>194...</b>	194295.....163	197556.....189	197676.....184	201395.....134
194017.....137	194296.....163	197557.....189	197677.....184	201541.....48
194018.....137	194297.....163	197558.....189		201942.....192
194019.....137	194298.....163	197559.....189	<b>198...</b>	201943.....192
194030.....137	194299.....163	197560.....189	198217.....201	201944.....192
194031.....137	194300.....163	197567.....190	198219.....201	201945.....192
194032.....137	194301.....163	197568.....190	198220.....201	201946.....192
194033.....137	194302.....163	197569.....190	198221.....201	
194034.....137	194303.....163	197570.....190	198222.....201	<b>203...</b>
194035.....137	194304.....163	197571.....190	198223.....201	203008.....46
194036.....137	194305.....163	197572.....190	198225.....201	203028.....18
194037.....137	194306.....163	197603.....174	198226.....201	203029.....18
194038.....137	194307.....163	197604.....174	198228.....201	203040.....18
194039.....138	194908.....206	197606.....174	198230.....201	203041.....18
194040.....138	194930.....206	197608.....177	198232.....201	203265.....48
194041.....138	194932.....206	197609.....177	198518.....48	203266.....48
194042.....138	194933.....206	197610.....177	198519.....48	203267.....47
194043.....138	194934.....206	197614.....177	198530.....48	203268.....48
194044.....138	194935.....206	197616.....177	198782.....180	203269.....48
194045.....138	194936.....206	197617.....177	198783.....181	203270.....47
194046.....138	194937.....206	197618.....175	198784.....184	203271.....48
194047.....138	194938.....206	197619.....175		203272.....48
194048.....138	194939.....206	197620.....175	<b>199...</b>	203274.....48
194049.....140	194940.....206	197621.....178	199151.....143	203278.....48
194050.....140	194941.....206	197622.....178	199152.....143	203279.....48
194051.....140	194942.....206	197623.....178	199154.....143	203280.....48
194052.....140	194943.....206	197624.....178	199155.....143	203281.....48
194053.....140	194944.....206	197625.....178	199157.....143	203282.....48
194054.....140	194945.....206	197626.....178	199158.....143	203283.....48
194055.....140	194947.....206	197627.....178	199159.....143	203284.....48
194056.....140	194949.....206	197628.....180	199160.....143	203285.....48
194057.....140	194950.....206	197629.....180	199162.....143	203674.....56
194058.....140		197630.....180	199163.....143	203675.....56
194059.....140	<b>195...</b>	197631.....180	199164.....143	203676.....56
194061.....140	195344.....200	197632.....180	199165.....143	203677.....56
194062.....140	195345.....200	197633.....180	199166.....143	203678.....56
194063.....140	195346.....200	197634.....180	199167.....143	203679.....56
194064.....141	195347.....200	197635.....180	199168.....143	203680.....56
194065.....141	195348.....200	197636.....180	199184.....145	203787.....56
194066.....141	195349.....200	197637.....180	199185.....145	203788.....56
194067.....141	195350.....205	197638.....181	199186.....145	203789.....56
194068.....141	195351.....205	197639.....181	199187.....145	203790.....56
194069.....141	195365.....166	197640.....181	199189.....145	203791.....56
194070.....141	195366.....169	197641.....181	199190.....145	203792.....56
194071.....141	195367.....220	197642.....181	199191.....145	203856.....48
194072.....132	195368.....220	197643.....181	199192.....145	203857.....47
194073.....132	195816.....88	197644.....181	199194.....145	203889.....48
194074.....132		197645.....181	199195.....145	203910.....48
194075.....132	<b>197...</b>	197646.....181	199196.....145	203911.....47
194076.....132	197515.....185	197647.....181	199197.....145	203912.....48
194077.....132	197516.....185	197658.....182	199198.....145	203913.....47
194078.....132	197517.....185	197659.....182	199199.....145	203914.....48
194079.....132	197531.....187	197660.....182	199362.....110	203915.....47
194080.....132	197532.....187	197661.....183		203916.....48
194082.....132	197533.....187	197662.....183	<b>200...</b>	203917.....47
194083.....132	197534.....187	197663.....183	200294.....56	203918.....48
194085.....132	197535.....187	197664.....183	200295.....56	203919.....47

203920.....48	223574.....230	250355.....256	264705.....272	<b>291...</b>
203921.....47	223575.....230	250358.....256	264769.....173	291122.....208
203922.....48	223576.....229	250711.....149	264988.....173	291178.....208
203923.....47	223577.....229	250715.....149		
203924.....48	223578.....229	250720.....148	<b>265...</b>	<b>293...</b>
203925.....47	223580.....228	250726.....148	265023.....155	293710.....257
203926.....48	223581.....228		265024.....155	293792.....146
203927.....47	223583.....227	<b>251...</b>	265196.....272	293797.....147
203928.....48	223585.....227	251713.....135	265205.....173	
203929.....47	223590.....226		265501.....173	<b>294...</b>
203930.....48	223591.....226	<b>252...</b>		294806.....12
203931.....47	223592.....226	252101.....135	<b>266...</b>	
203934.....48	223594.....224	252110.....224	266811.....207	<b>295...</b>
203935.....47	223595.....224			295167.....146
	223596.....224	<b>254...</b>	<b>267...</b>	295283.....147
<b>204...</b>	223597.....224	254684.....27	267685.....207	
204008.....51	223598.....224		267708.....207	<b>297...</b>
204010.....51	223599.....224	<b>255...</b>		297104.....161
204011.....51	223600.....224	255159.....105	<b>268...</b>	297260.....161
204012.....51	223602.....224	255404.....255	268322.....29	297310.....161
204013.....51	223603.....224	255897.....257	268323.....29	297311.....161
204014.....51	223604.....225		268324.....29	297348.....161
204015.....51	223605.....225	<b>256...</b>		297349.....161
204016.....51	223606.....223	256010.....149	<b>289...</b>	297350.....161
204017.....51	223607.....223	256328.....149	289677.....207	297351.....161
204018.....51	223609.....223	256838.....151	289894.....144	297352.....161
204019.....51		256839.....151	289897.....144	297353.....161
204020.....51	<b>224...</b>		289898.....144	297358.....161
204021.....51	224826.....149	<b>257...</b>	289899.....144	297360.....161
204022.....51	224853.....158	257581.....151	289900.....144	297361.....161
204023.....51		257582.....151	289901.....144	297362.....161
204024.....51	<b>225...</b>	257622.....154	289902.....144	297433.....161
204025.....51	225844.....157		289903.....144	297441.....162
204026.....51		<b>258...</b>	289904.....144	297442.....162
204027.....51	<b>237...</b>	258130.....130	289905.....144	297443.....162
204028.....51	237858.....192	258131.....130	289906.....144	297444.....162
204029.....51	237859.....192	258132.....130	289907.....144	297449.....162
204030.....51	237860.....192	258133.....130	289908.....144	297460.....162
204031.....51	237861.....192	258135.....130	289909.....144	297461.....162
204032.....51	237862.....192	258136.....130	289910.....144	297462.....162
204033.....51		258137.....130	289911.....144	297463.....162
204034.....51	<b>240...</b>	258138.....130	289912.....144	297464.....162
204035.....51	240160.....60	258140.....130	289945.....142	297465.....162
204297.....56	240163.....60	258141.....130	289947.....142	297466.....162
204298.....56	240167.....60	258142.....130	289948.....142	297467.....162
204299.....56	240168.....60	258143.....130	289949.....142	297468.....162
204310.....56	240170.....60	258144.....130	289950.....142	297469.....162
204311.....56	240357.....276	258145.....130	289951.....142	
204312.....56	240358.....276	258146.....130	289952.....142	
204313.....56		258494.....212	289953.....142	<b>299...</b>
	<b>246...</b>	258495.....212	289954.....142	299001.....98
<b>219...</b>	246176.....148	258496.....212	289955.....142	299002.....98
219647.....267	246993.....267		289956.....142	299003.....98
		<b>259...</b>	289957.....142	
<b>220...</b>	<b>247...</b>	259101.....159	289958.....142	<b>301...</b>
220775.....149	247102.....148		289959.....142	301492.....153
		<b>262...</b>	289960.....142	
<b>221...</b>	<b>249...</b>	262054.....152	289961.....142	<b>302...</b>
221122.....101	249698.....246	262055.....152	289962.....142	302227.....160
221276.....199	249699.....246	262056.....152	289963.....142	302732.....149
221277.....199	249700.....246	262697.....12	289968.....208	
	249701.....246	262699.....12		<b>306...</b>
<b>222...</b>	249702.....247	262704.....131		306220.....135
222242.....71	249703.....247	262710.....12	<b>290...</b>	
		262816.....152	290443.....136	<b>307...</b>
<b>223...</b>	<b>250...</b>		290444.....136	307013.....267
223131.....71	250351.....256	<b>264...</b>	290812.....208	307669.....29
223132.....71	250354.....257	264366.....156		

**308...**

308543 .....131

**309...**

309283 .....150  
 309284 .....150  
 309445 .....116  
 309446 .....116  
 309447 .....116  
 309448 .....118  
 309449 .....118  
 309514 .....136  
 309516 .....136  
 309517 .....136  
 309519 .....136  
 309520 .....136  
 309521 .....136  
 309522 .....136  
 309523 .....136  
 309525 .....136  
 309526 .....136  
 309527 .....136  
 309528 .....136  
 309529 .....136  
 309530 .....136  
 309534 .....139  
 309535 .....139  
 309536 .....139  
 309537 .....139  
 309539 .....139  
 309540 .....139  
 309541 .....139  
 309542 .....139  
 309545 .....139  
 309546 .....139  
 309548 .....139  
 309550 .....139  
 309551 .....139  
 309552 .....139  
 309553 .....139  
 309554 .....139  
 309583 .....168  
 309800 .....165  
 309801 .....165  
 309802 .....165  
 309806 .....165  
 309807 .....165  
 309808 .....165  
 309810 .....165  
 309811 .....165  
 309812 .....165  
 309813 .....168  
 309815 .....168  
 309816 .....168  
 309820 .....168  
 309821 .....168  
 309822 .....168  
 309823 .....168  
 309824 .....168

**310...**

310553 .....117

**311...**

311594 .....125

**312...**

312445 .....135

**313...**

313461 .....208  
 313462 .....207

**317...**

317353 .....104

**320...**

320436 .....116

**329...**

329567 .....92  
 329569 .....92  
 329572 .....92  
 329587 .....92  
 329588 .....92  
 329589 .....92

**331...**

331184 .....131

**335...**

335120 .....119  
 335121 .....119  
 335565 .....92  
 335566 .....92  
 335567 .....85  
 335750 .....104

**336...**

336260 .....179  
 336261 .....179  
 336263 .....179  
 336264 .....179  
 336538 .....176  
 336550 .....176  
 336551 .....176  
 345619 .....27



<b>A</b>							
AK	212	CTS 1250A	150	M...MS6	126	SKHD	69
AUF	220	CVS 250A	157	Mounting ring	156	SM	23
AVS	216	CWS 250A	146	MR 0	77	SMDH	26
AVUS	216	CWS 400A	148	MSFA	22	SMH	14, 15
AZK	278			MULTI	270	SMH3...MS6	124
		<b>D</b>		M...V-Euroline	81	SMH4...Pb-RF	28
		D1	100	MZ	82	SMHA4	16
		DB	247	MZ...FG	83	SMHC	18
		DK-AL-LD	206			SMHC...E90	19
		DK-CU-V	204	<b>N</b>		SMH...E90	19
		DK-CU-V-LD	205	No. 26	241	SMHF	20
		DR	217	No. 60	238	SMH...G	17
		DUCT SEAL	276	No. 61	239	SMHSV	12
		DUSTER	268	No. 62	238	SMHSV3-1...MS6	125
		DV-AL	200	No. 63	237	SMHSV4...Pb-RF	29
		DV-AL-CU	202	No. 64	234	SMH...V	13
		DV-CU-V	198	No. 72	242	SM-MA	23
		DVZ-AL-LD	201	No. 90	235	SR1F	46
		DVZ-CU-V-LD	199	No. 128	231	SR1F3	50
				No. 228	233	SR2	62
		<b>E</b>				SR2LK	41
		EASYCELL®	116, 117, 118	<b>P</b>		SR2LK-PEN	41
		EASY-CLEAN	272	P...EG	89	SR3	65
		EASY-FIX (SRMH)	27	P...GG	91	SRAT	194
		EASY-GLIDE	267	PLASTIC	264	SRBB	192
		EG	102	Power Gel	119	SRBK-Set	68
		EGA	219	Premio 233	223	SRC1	44
		ELECTRO 2-26	260	Premio 235	224	SRFH2	64
				Premio 388	225	SRFH3	67
		<b>F</b>		Premio 845	226	SRH2	62
		FG	106	Premio 1130	227	SRH3	65
		FK	213	Premio 1180	228	SRMAHV	73
		FKS	213	Premio 2281	229	SRMH (EASY-FIX)	27
				Premio 5584	230	SRUM	60
		<b>G</b>		PV...EG	84	ST-PO	211
		GG	104	PVM...EG	84	SVL	279
				PVS...EG	84		
		<b>H</b>		PVS...GG	85	<b>T</b>	
		H	87	PZ1	253	T	93
		H 5-SYS	88	PZ2	254	T...V AK	95
		HB	244			<b>U</b>	
		HE 1/70/150	209	<b>R</b>		UG	108
		HG 2310 LCD	252	RB	246	Universal Box KG	101
		HKB	240	RF	273	UNIVERSAL CLEANER 121	258
				RH	203	URETHAN	262
		<b>I</b>				UWR	110
		INDUSTRIE 3-36	261	<b>S</b>		<b>V</b>	
				SAS	280	V	214
		<b>K</b>		SB	53, 55	VASMI	21
		KA	86	SBS	57	VI	214
		KAV	86	SEEV	127	VS	214
		KG	105	SEEV-F	128		
		KP	215	SEH	71	<b>W</b>	
		KRS	243	SEH4...A+Z	40	WG	112
		KS	248	SEH4...S-C	39	<b>Y</b>	
		KZ	275	SEH4...V-C	38	Y	96
		KZB	249	SEH4...V-S	37	YCP	99
				SEM	31	Y...V AK	98
		<b>L</b>		SEM4-K	30	<b>Z</b>	
		LG	274	SEM4-K...Pb	32	ZINC SPRAY 171	259
		LW	277	SESCW	35	ZS-CTS	154
				SESPB	36	ZS-PPb	25
		<b>M</b>		SFEH	34		
		M	78	SFEX	33		
		MBS	58	SHE	42		
		M-Euroline	80	SILICON	265		
		MINUS	269	Silicone grease	271		
		MMK	59	SKH	69		

## #

- 1-core indoor cable terminations
  - for all 1-core polymeric cables . . . . .137, 143
  - with screw cable lugs, for all 1-core polymeric cables . .136, 142
- 1-core outdoor cable terminations
  - for all 1-core polymeric cables . . . . .140, 145
  - with screw cable lugs, for all 1-core polymeric cables . .139, 144
- 1-core straight-through joints
  - for all 1-core polymeric cables . . . . .132, 134
  - with screw connector, for all 1-core polymeric cables. . 130, 131, 135
- 3-core indoor cable terminations
  - for all 3-core polymeric cables . . . . .166, 167
  - for armoured 3-core polymeric cables without semi-conductive layer up to 7.2 kV . . . . .127
  - with screw cable lugs, for all 3-core polymeric cables . . . . .165
- 3-core outdoor cable terminations
  - for all 3-core polymeric cables . . . . .169, 170
  - for armoured 3-core polymeric cables without semi-conductive layer up to 7.2 kV, . . . . .128
  - with screw cable lugs, for all 3-core polymeric cables . . . . .168
- 3-core straight-through joints
  - for all 3-core polymeric cables . . . . .163, 164
  - for armoured 3-core polymeric cables without semi-conductive layer up to 7.2 kV . . . . .124, 126
  - with screw connectors, for all 3-core polymeric cables . . . . .161

## A

- Accessory kits
  - for mass-impregnated paper cables for heat shrinkable universal straight-through joints SM and SM-MA . . . . .25
  - for separable connectors type CTS . . . . .154
- All-weather PVC tape for insulation and bundling, in practical plastic box . . . . .225
- Anti-corrosion spray . . . . .259
- Armour transition for 3-core joints for armoured cables, for medium voltage . . . . .220
- Assembly guide for CWS 250A and CGS 250A . . . . .156
- Assembly help for screw connectors type CSV and screw cable lugs type CSK . . . . .255
- Assembly kit for branching with heat shrinkable joints SMHF and VASMI . . . . .22
- Assortment box with thin wall heat shrinkable tubes and cable ties . . . . .58

## B

- Branch clamps
  - for cast resin branch joints, for low voltage . . . . .215
  - for low voltage . . . . .209, 210
- Branch clamp for sealing of multiple cable entry points . . . . .278
- Branching kit for telecommunication cables . . . . .280

## C

- Cable centring aid . . . . .275
- Cable marker . . . . .250
- Cable repair kit for damaged cables and conductors . . . . .27
- Cable ties, standard . . . . .248
- Cast resin branch joints
  - for polymeric cables and conductors . . . . . 86, 87, 93, 96, 99
  - with integrated strain relief, for polymeric cables and mass-impregnated paper cables, with cast resin EG . . . .89
  - with integrated strain relief, for polymeric cables and mass-impregnated paper cables, with cast resin GG (reduced hazard-class) . . . . .91
  - with screw branch clamps, for polymeric cables and conductors . . . . .95, 98
- Cast resin branch joint for house connections with branch clamp, for unarmoured polymeric cables . . . . .88

- Cast resin branch / straight-through joint particularly for small cross sections for polymeric cables and conductors, control cables and signal cables . . . . .100
- Cast resin straight-through joints
  - drummable, with flexibel cast resin, for unarmoured polymeric cables and conductors . . . . .83
  - for control cables and signal cables . . . . .82
  - for polymeric cables and conductors . . . . .80
  - for polymeric cables and conductors, control cables and signal cables. . . . .78
  - particularly for small cross sections, for polymeric cables and conductors, control cables and signal cables . . . .77
  - with integrated strain relief, for polymeric cables and conductors, with cast resin EG . . . . .84
  - with integrated strain relief, for polymeric cables and conductors, with cast resin GG (reduced hazard-class) . . . . .85
  - with screw connectors, for polymeric cables and conductors .81
- Cleaner . . . . .258
- Cleaning spray . . . . .263, 268
- Clear varnish . . . . .264
- Cloth tape for marking and labeling . . . . .235
- Compression cable lug Al according to DIN 46235 longitudinally sealed, for low and medium voltage . . . . .206
- Compression cable lugs Cu according to DIN 46235
  - for low and medium voltage . . . . .204
  - longitudinally sealed, for low and medium voltage. . . . .205
- Compression connectors Al according to DIN 46267
  - without separator, for low and medium voltage up to 10 kV . . 200
  - with separator, for low and medium voltage up to 10 kV. . . . 201
- Compression connector Al-Cu according to DIN 40500 with separator, for low and medium voltage up to 10 kV . . . . .202
- Compression connectors Cu according to DIN 46267
  - without separator, for low and medium voltage up to 10 kV . . 198
  - with separator, for low and medium voltage up to 10 kV. . . . 199
- Conductive tape to control electric fields, self-amalgamating . .239
- Connecting element up to 24 kV for separable cable connectors type CWS and type CGS, for outer cone system terminals type A. . . . .157
- Connection and branch box with clamps . . . . .101
- Cooling spray . . . . .269
- Copper braid tape for shielding and potential control . . . . .237
- Copper foil for discharge of electrostatic charge and screening of components, in practical plastic box . . . . .229
- Coupling element up to 36 kV for T-shaped separable connectors type CTS . . . . .158
- Coupling surge arresters
  - Class 1, for separable connector type CTS . . . . .152
  - Class 2, for separable connector type CTS . . . . .153

## E

- Earthing clamp for low voltage . . . . .218
- Earthing set for cables with tape screen and/or armouring for cable terminations, for low and medium voltage . . . . .219
- Elbow separable cable connectors for all 1-core polymeric cables
  - for outer cone system terminals type A . . . . .146
  - for outer cone system terminals type B . . . . .148

## F

- Fastening element for cable ties . . . . .249
- Fibreglass tapes for heat-proof electrical and mechanical insulation
  - 130 °C . . . . .227
  - 180 °C . . . . .228

## G

- Gel branch joint with branch-off block . . . . .118
- Gel straight-through joint with connection block . . . . .116

<b>H</b>	
Hand wipes	272
Heating system, for roofs and gutter	247
Heat shrinkable cable terminations	
· for mass-impregnated paper cables	36
· for polymeric cables with concentric conductor	35
· for unarmoured polymeric cables	34
· for unarmoured polymeric cables and conductors	33
Heat shrinkable crimp connector insulated with heat shrinkable tube, with adhesive, for low voltage	217
Heat shrinkable end cap with adhesive, optionally with additional sealing material	69
Heat shrinkable indoor and outdoor cable termination for polymeric cable with concentric conductor and armoured polymeric cables, with or without connectors	40
Heat shrinkable indoor cable terminations	
· for armoured polymeric cables	37
· for polymeric cables with concentric conductor	38, 39
Heat shrinkable medium wall tubes	
· halogen-free, shrink ratio 3 : 1, with or without adhesive	62
· protection for busbar systems and reduction of minimum clearance, halogen-free, shrink ratio 3 : 1	192
· self-extinguishing, flexible, shrink ratio 3 : 1 or 4 : 1, with adhesive	60
· self-extinguishing, shrink ratio 3 : 1, with adhesive	64
Heat shrinkable repair sleeve with adhesive and stainless steel channel	73
Heat shrinkable spreader cap for 2-, 3-, 4-, 5-core cables and conductors, with adhesive	71
Heat shrinkable straight-through joints	
· for armoured polymeric cables	26
· for fire-resistant cables E90 according to DIN standard 4102 Section 12	19
· for flexible cables	17
· for polymeric cables with concentric conductor	18
· for tape and wire armoured polymeric cables	16
· for telecommunication cables	20
· for unarmoured polymeric cables and conductors	14
· with heat shrinkable crimp connectors, for control cables and signal cables	15
· with screw connectors, for unarmoured polymeric cables and conductors	13
· with screw connectors (with shear head bolts), for unarmoured polymeric cables and conductors	12
· with temperature colour indicator, for telecommunication cables	21
Heat shrinkable thick wall tubes	
· anti-slip, halogen-free, shrink ratio 3 : 1, with adhesive	68
· halogen-free, shrink ratio 3 : 1	194
· halogen-free, shrink ratio 3 : 1, with or without adhesive	65
· self-extinguishing, shrink ratio 3 : 1, with adhesive	67
Heat shrinkable thin wall tubes	
· halogen-free, shrink ratio 2 : 1, without adhesive	44
· self-extinguishing, shrink ratio 2 : 1, without adhesive	46
· self-extinguishing, shrink ratio 3 : 1, without adhesive	50
Heat shrinkable transition joints	
· with screw connectors, with solderless earthing wire connection, for polymeric cables and mass-impregnated paper cables	29
· with solderless earthing wire connection, for polymeric cables and mass-impregnated paper cables	28
Heat shrinkable tubes in dispenser box	
· thin wall, self-extinguishing, shrink ratio 2 : 1, without adhesive	53, 57
· thin wall, self-extinguishing, shrink ratio 3 : 1, without adhesive	55
Heat shrinkable tube kit for phase marking	41
Heat shrinkable universal straight-through joint for polymeric cables, conductors and mass-impregnated paper cables	23
Heat shrinkable wall duct for cables and conductors	42
Heat shrink torch kit for installation of heat shrinkable products	251
High voltage insulation tape for insulation and padding, self-amalgamating	238
Hot air blower for installation of heat shrinkable products	252
Hot melt adhesive for sealing against humidity	244
<b>I</b>	
Indoor cable terminations	
· for 3 lead sheath cables from 24 to 36 kV	189
· for belted cables up to 17.5 kV (MIND)	185
· for H-Type cables from 24 to 36 kV	187
Insulating and lubricating oil spray	265
<b>L</b>	
Lubricant for feeding cables and conductors	267
Lubricant spray for feeding cables and conductors	266
Lubricating grease	271
<b>M</b>	
Mastic tape	240
Mechanical crimping pliers	
· for heat shrinkable crimp connectors DR	254
· for wire connectors AVS and AVUS	253
Mini joint case with medium wall heat shrinkable tubes and heat shrinkable crimp connectors, for joints up to 2.5 mm <sup>2</sup>	59
Multi-function oil spray	270
Multi tool for the preparation of medium voltage cables	256
<b>O</b>	
Outdoor cable terminations	
· for 3 lead sheath cables from 24 to 36 kV	190
· for belted cables up to 17.5 kV (MIND)	186
· for H-Type cables from 24 to 36 kV	188
<b>P</b>	
Pressure spring	273
Protective agent	
· for protection of electrical equipment	260
· for protection of metals	261
Protective insulating varnish	262
Putty/sealing compound for sealing of wall ducts	274
PVC electrical insulation tapes in practical plastic box	
· for insulation and bundling	223
· for marking and bundling	224
PVC insulation tape for marking, bundling and insulating	231, 233
<b>R</b>	
Reduction sleeve Cu for low voltage	203
Repair kit for repairing damaged cable sheaths, incl. accessories	243
Repair tape for repairing damaged cable sheaths, self-amalgamating	242
<b>S</b>	
Screw branch clamp Al-Cu for cast resin straight-through and branch joints, for low voltage	212
Screw cable lug for Cu and Al, longitudinally sealed, with shear head bolts, for low and medium voltage	208
Screw connector Al-Cu for low voltage	214
Screw connector for Cu and Al, longitudinally sealed, with shear head bolts, with separator, for low voltage	207
Sealing tape for permanently flexible sealing, self-amalgamating	234
Self-adhesive foam tape for universal fixation	230

Shield continuity wire for telecommunication cables . . . . .	279
Splice cassette system for fibre optic cables . . . . .	277
Split bolt clamp for cast resin straight-through and branch joints, for low voltage . . . . .	213
Steel compression sleeve for low voltage . . . . .	211
Straight separable cable connector for all 1-core polymeric cables, for outer cone system terminals type A . . . . .	147
Straight-through joints	
· for 3 lead sheath cables up to 36 kV . . . . .	184
· for belted cables/H-Type cables up to 17.5 kV (MIND) . . . . .	182
· for H-Type cables from 24 to 36 kV . . . . .	183
· with screw connectors, for connecting from 3-core with 1-core polymeric cables . . . . .	162
· with screw connectors, for connecting from 3-core with 1-core polymeric cables up to 7.2 kV . . . . .	125
Strain relief for gel straight-through joints EASY 4 V and EASY 5 V . . . . .	117
Stripping tool for the preparation of medium voltage cables . . . . .	257

### T

Tape for cable bundle . . . . .	226
Test and earthing kit for Cellplux separable cable connectors type CTS and type CTKS . . . . .	159
Test kit for Cellplux separable cable connectors type CTS and type CTKS . . . . .	160
Trace heating system, self-regulating . . . . .	246
Transition joints	
· for 3 lead sheath cables to 1-core polymeric cables . . . . .	180
· for 3 lead sheath cables to 3-core polymeric cables . . . . .	181
· from belted cables/H-Type cables to 1-core polymeric cables . . . . .	174
· from belted cables/H-Type cables to 3-core polymeric cables . . . . .	175
· from H-Type cables to 3-core polymeric cables . . . . .	178
· from H-Type cables to polymeric 1-core cables . . . . .	177
· with screw connectors, for 3 lead sheath cables to 1-core polymeric cables . . . . .	179
· with screw connectors, from belted cables/H-Type cables to 1-core polymeric cables . . . . .	173
· with screw connectors, from H-Type cables to polymeric 1-core cables . . . . .	176
T-shaped separable connector for all 1-core polymeric cables, for outer cone system terminals type C . . . . .	149, 150
T-shaped separable coupling connector for all 1-core polymeric cables, for separable connector type CTS . . . . .	151
Two-component gel to cast branch and connection boxes . . . . .	119
Two-component PUR cast resins	
· flame retardant . . . . .	108
· flexible . . . . .	106
· low reactivity to water . . . . .	110
· reduced hazard-class . . . . .	104
· removable . . . . .	105, 112
· universal . . . . .	102

### U

Universal sealing compound . . . . .	276
--------------------------------------	-----

### V

Voltage-resistant insulating cap for plug-in connections type A 250A and type C 630A . . . . .	155
Voltage-resistant pot end joints	
· with inner cap, for mass-impregnated paper cables . . . . .	32
· with inner caps and outer cap, for polymeric cables and conductors . . . . .	30
· with inner sleeves and outer cap, for polymeric cables and conductors . . . . .	31

### W

Warning tape . . . . .	241
Wire connector for telecommunication and signal cables . . . . .	216

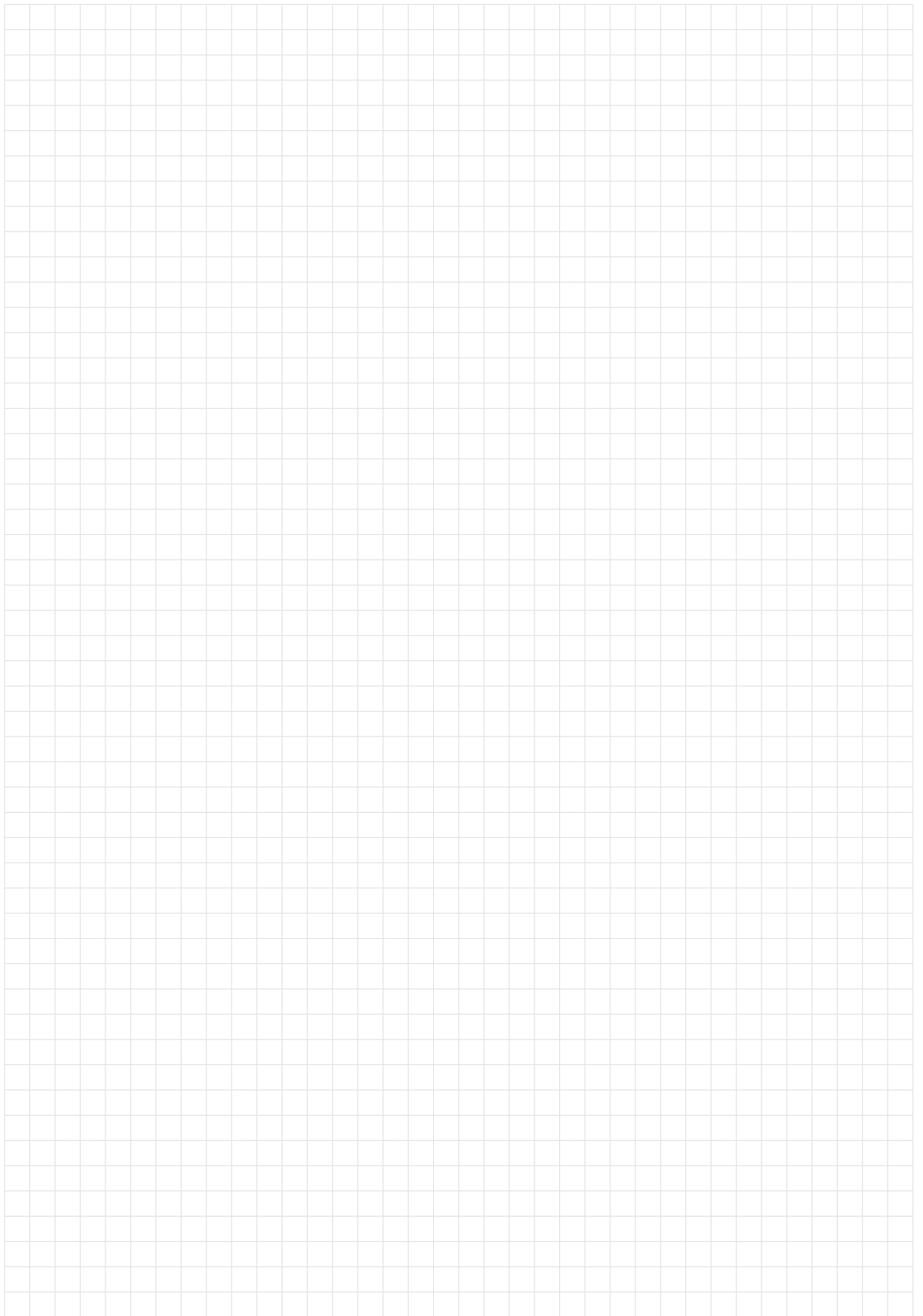

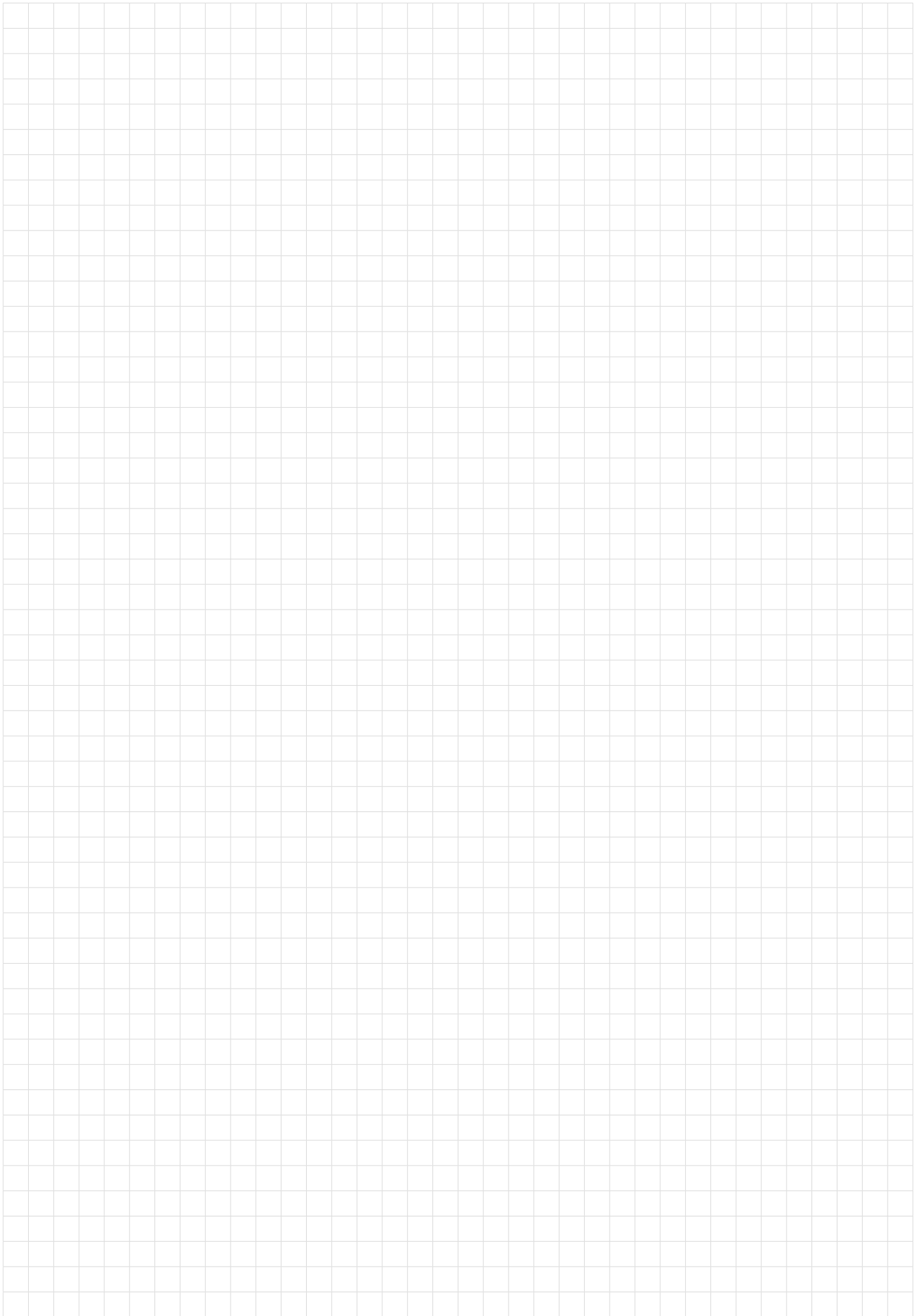



## INTERNATIONAL SALES ORGANISATIONS

### Europe

**Cellpack AG**  
**Electrical Products**  
Anglikerstrasse 99  
5612 Villmergen  
Schweiz  
Tel. +41 56 618 12 34  
Fax +41 56 618 12 45  
verkauf.epschweiz@cellpack.com

**Cellpack GmbH**  
**Electrical Products**  
Carl-Zeiss-Straße 20  
79761 Waldshut-Tiengen  
Deutschland  
Tel. +49 7741 6007-0  
Fax +49 7741 64989  
electrical.products@cellpack.com

**Cellpack Benelux B.V.**  
Keersluisweg 13  
1332 EE Almere Buiten  
Nederland  
Tel. +31 36 549 03 36  
Fax +31 36 532 74 99  
info@cellpack.nl

**Cellpack Polska Sp. z o.o.**  
ul. Matuszewska 14,  
03-876 Warszawa  
Polska  
Tel. +48 22 853 53 54  
Fax +48 22 853 53 56  
biuro@cellpack.pl

**Cellpack Italia Srl**  
Via Petrarca, 2  
22100 Como  
Italia  
Tel. +39 349 903 21 28  
EPSalesExport@cellpack.com

**Behr Bircher Cellpack**  
**Ibérica, S.A.**  
C/.Mas Pujol, nr. 47 – Nave 4  
Pol. Ind. Sector V  
08520 – Les Franqueses del Vallès  
Barcelona – España  
Tel. +34 93 846 63 76  
Fax +34 93 849 12 06  
comercial@cellpackiberica.com

**Behr Bircher Cellpack**  
**BBC France s.à.r.l.**  
277, Boulevard des Technologies  
54710 Ludres  
France  
Tel. +33.3.83.25.60.07  
Fax +33.3.83.25.88.27  
info@cellpack-ep.fr

### Middle East

**Behr Bircher Cellpack**  
**BBC AG DMCC Branch**  
Jumeirah Lakes Towers  
Dubai, UAE  
Tel. +971 50 952 28 00  
EPSalesME@cellpack.com

### Asia Pacific

**Cellpack Far East (PTE) LTD.**  
128 Joo Seng Road # 06 – 01  
Singapore 368356  
Tel. +65 6747 7024  
Fax +65 6841 4554  
info@cellpack.com.sg

**Behr Bircher Cellpack**  
**BBC Malaysia Sdn. Bhd.**  
No. 8, Jalan TU 50  
Taman Tasik Utama  
Ayer Keroh  
75450 Melaka  
Malaysia  
Tel. +60 6 251 95 30  
Fax +60 6 251 95 31  
info@cellpack.com.my  
www.cellpack.com.my

**Behr Bircher Cellpack**  
**BBC Australia Pty Ltd**  
PO Box 73  
Oakdale, NSW, 2570  
Australia  
Tel. +61 407 103 621  
Fax +61 2 4659 6531  
New Zealand  
Tel. +64 21 591 960  
Fax +64 9 436 0897  
salesanz@cellpack.com



Further information  
on our products:  
[electricalproducts.cellpack.com](http://electricalproducts.cellpack.com)

[www.cellpack.com](http://www.cellpack.com)

Systems For Professionals

**CELLPACK**  
Electrical Products

a BBC GROUP company