

Ver instructivo para su uso adecuado.

Guía Rápida

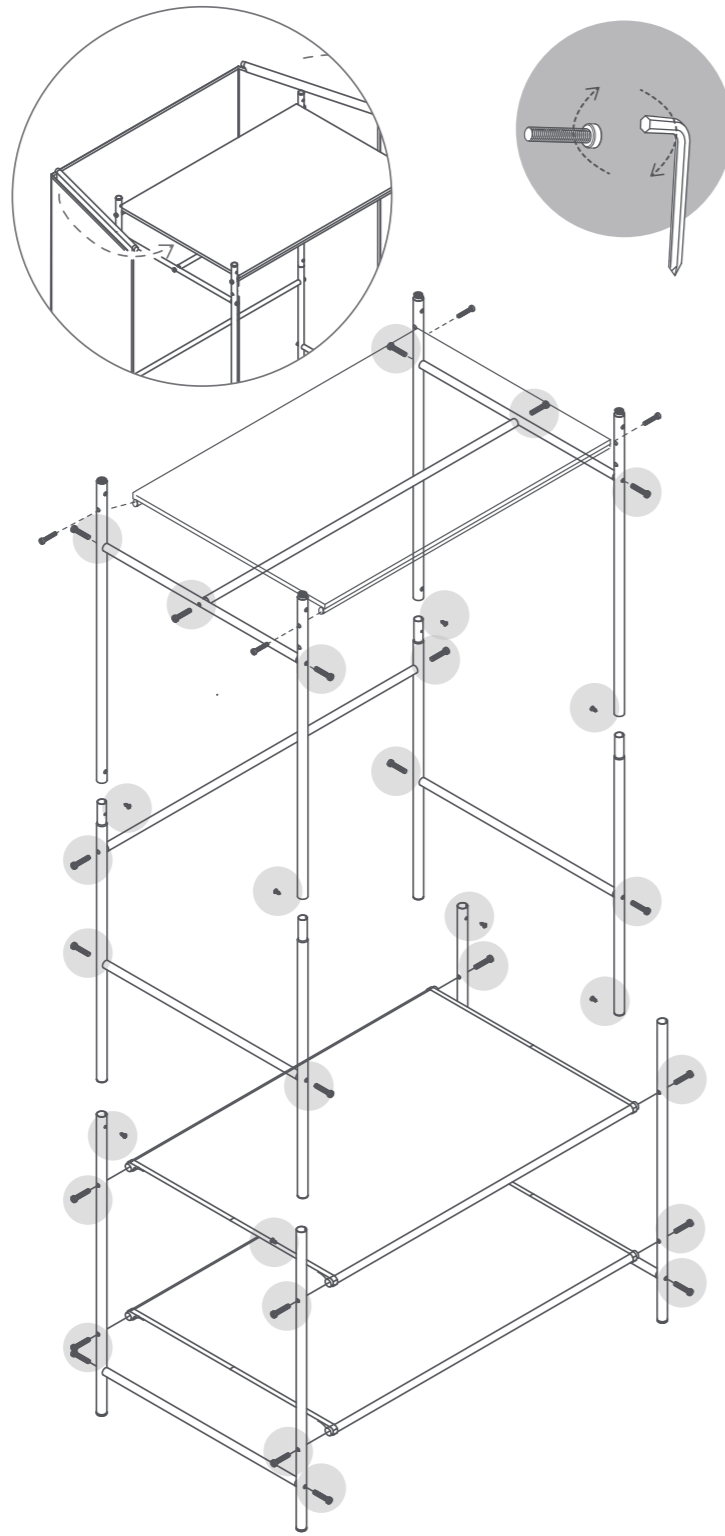

1 Identifica

- (A) X 2
- (B) X 2
- (C) X 2
- (D) X 4
- (E) X 2
- (F) X 7
- (G) X 2
- (H) X 6
- (I) X 1
- (J) X 2
- (K) X 1
- (L) X 1
- (M) X 34
- (N) X 4
- (O) X 8
- (P) X 2
- (Q) Llave

2 Arma repisas

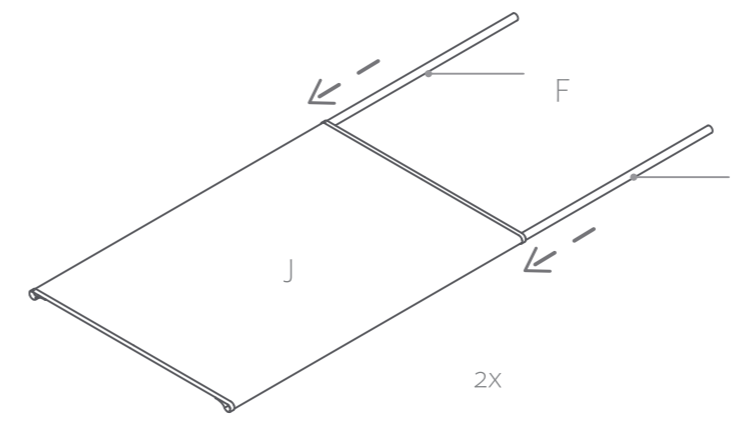

3 Une las repisas

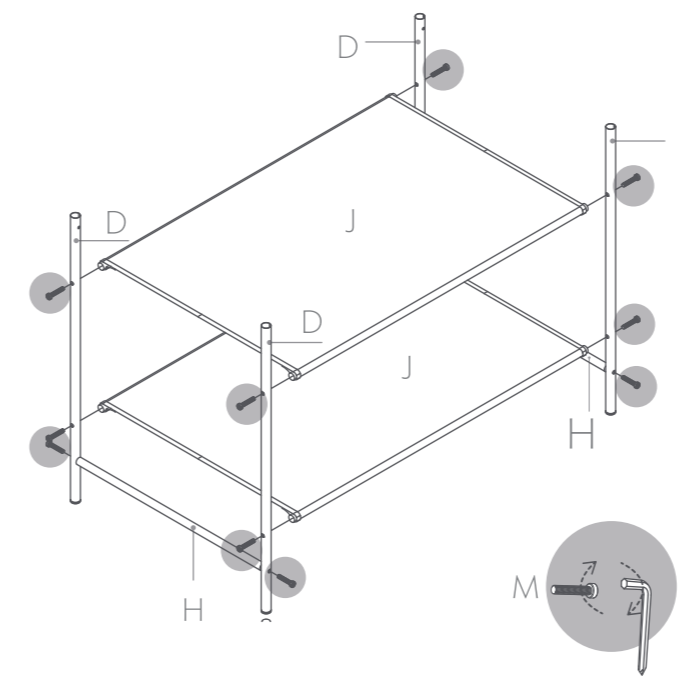

4 Arma estructura superior

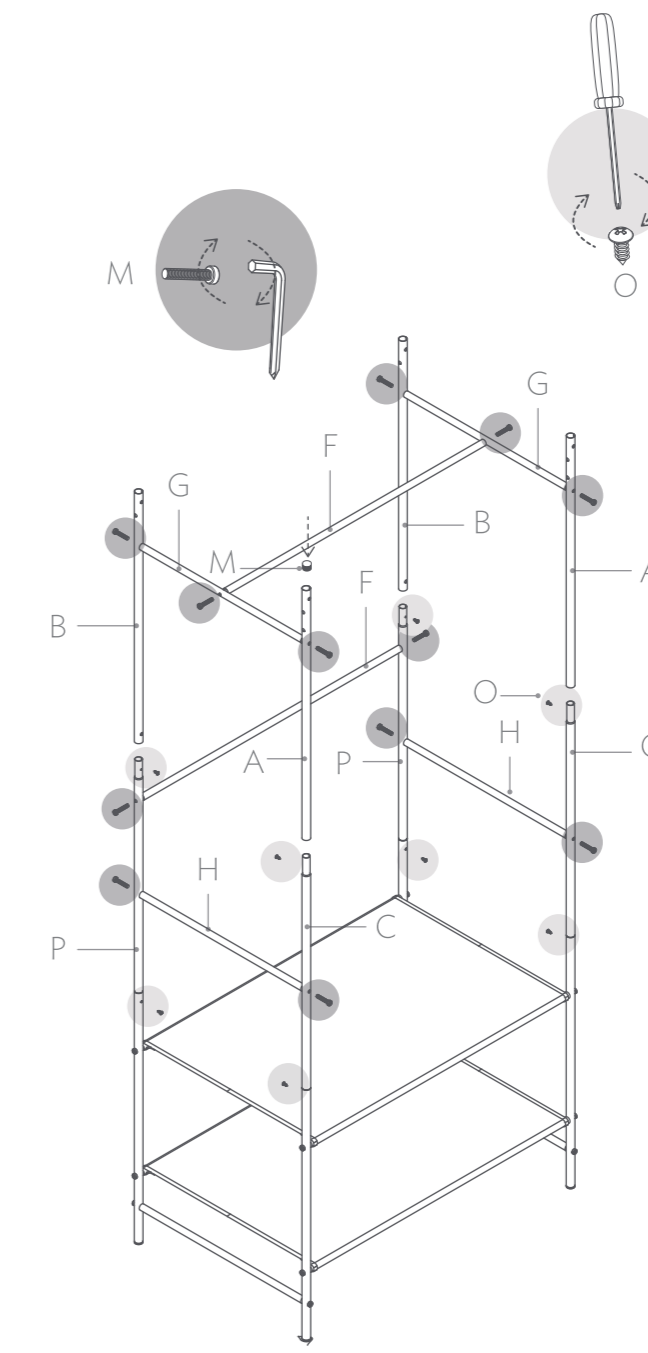

5 Arma techo

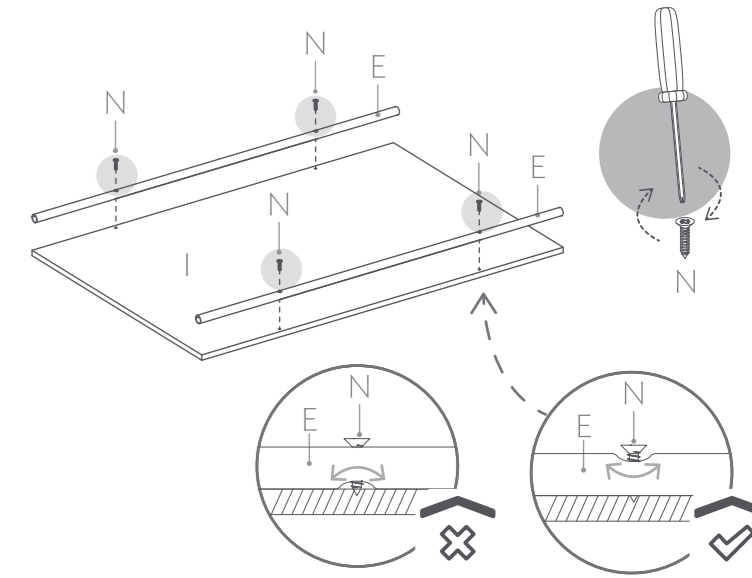

Evita apretar de más las pijas para no dañar la madera.

6 Coloca el techo

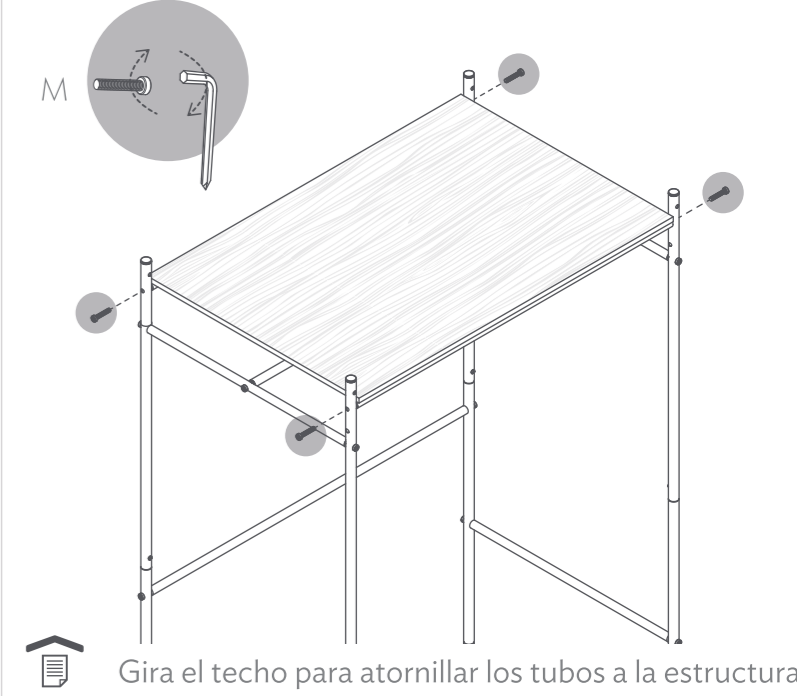

Gira el techo para atornillar los tubos a la estructura.

7 Arma cubierta trasera

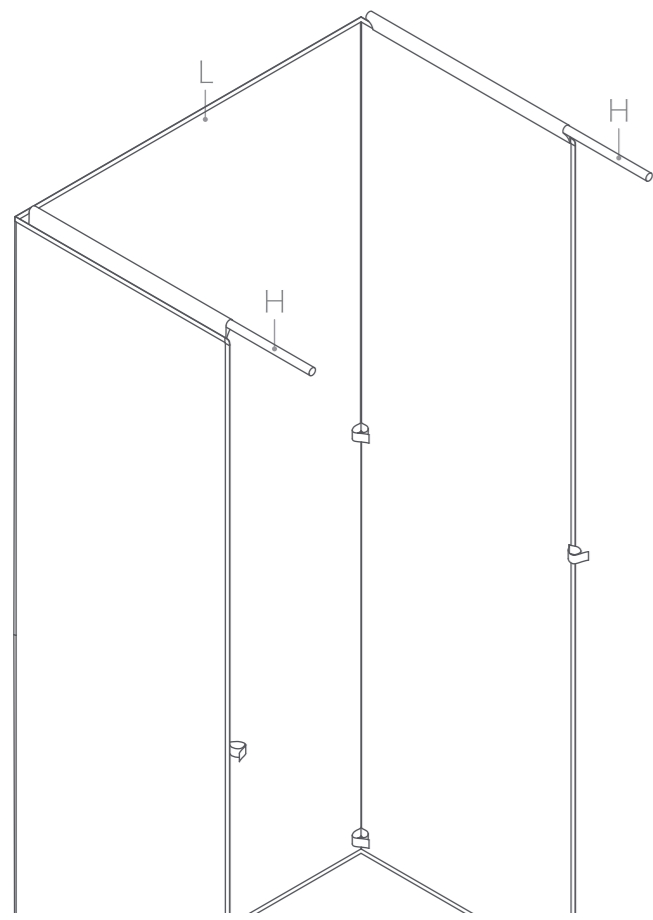

8 Coloca cubierta trasera

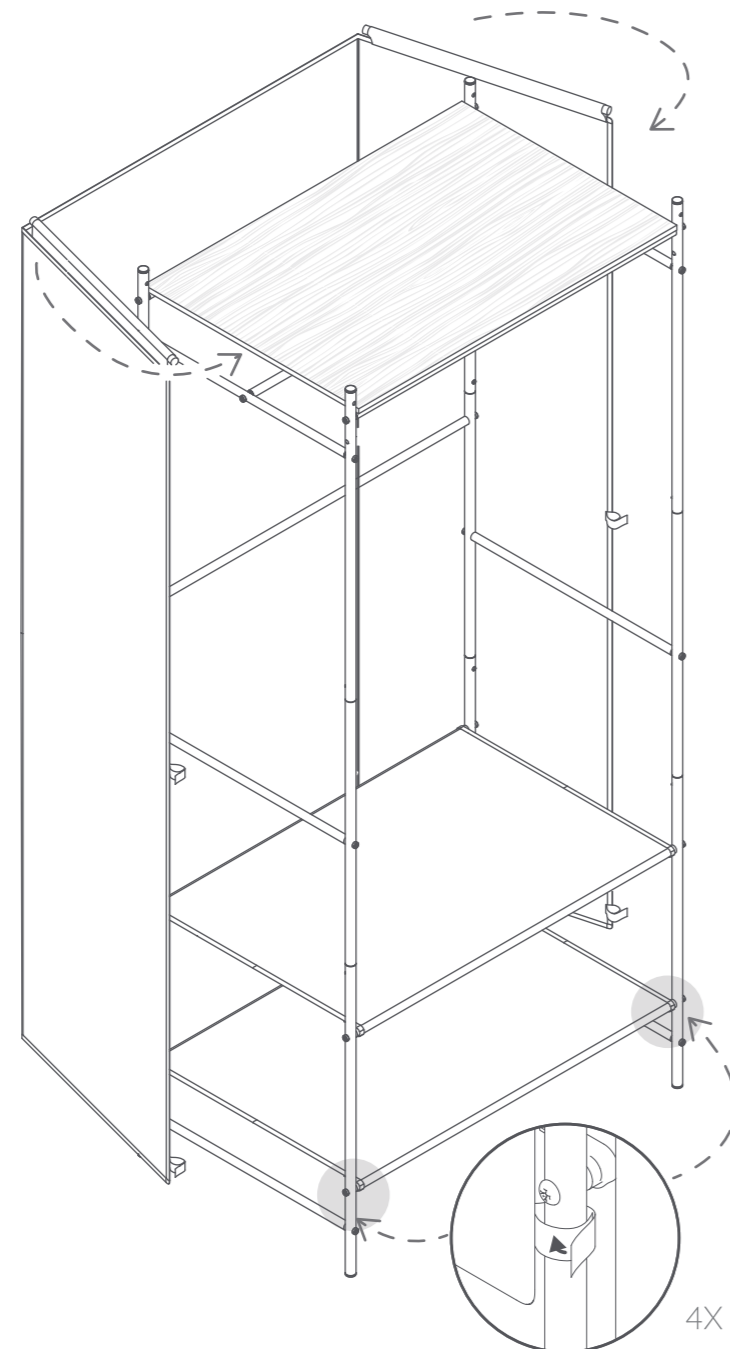

Sujeta los velcros por debajo de la última repisa para evitar que se mueva la cubierta.

9 Fija cubierta trasera

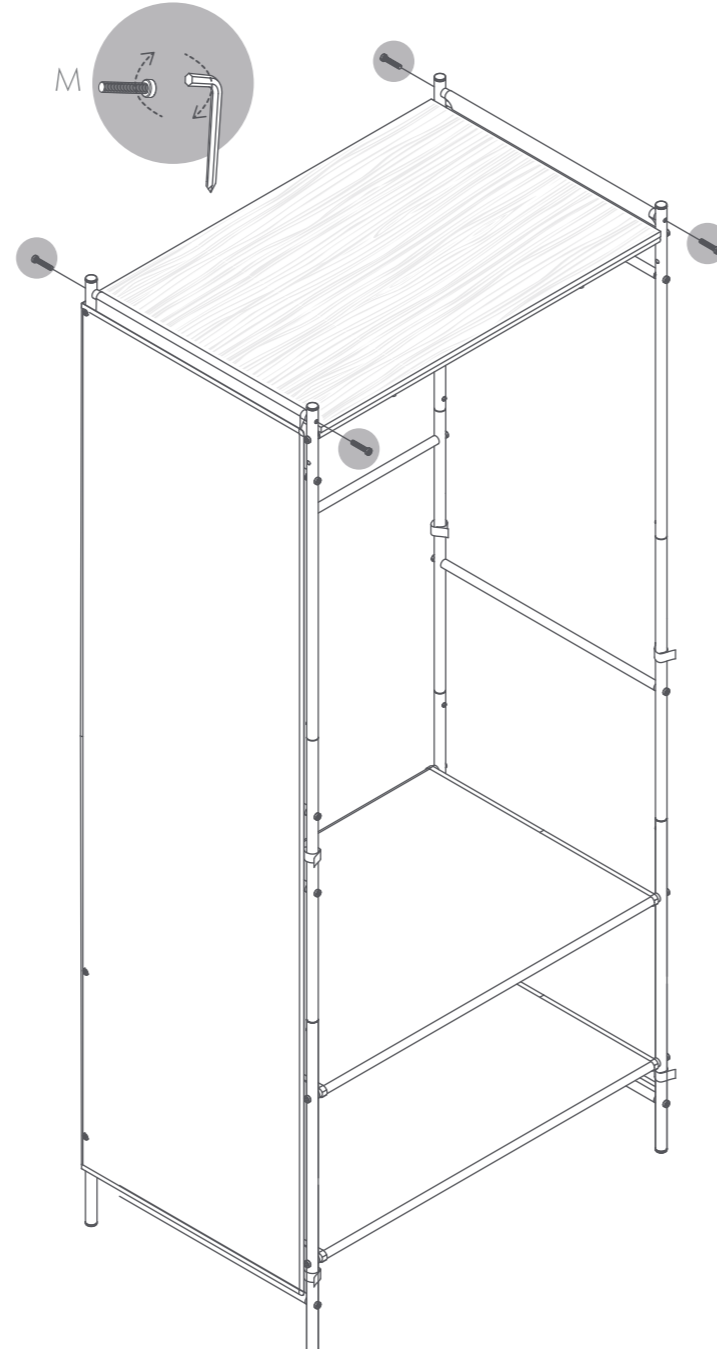

10 Arma cortina

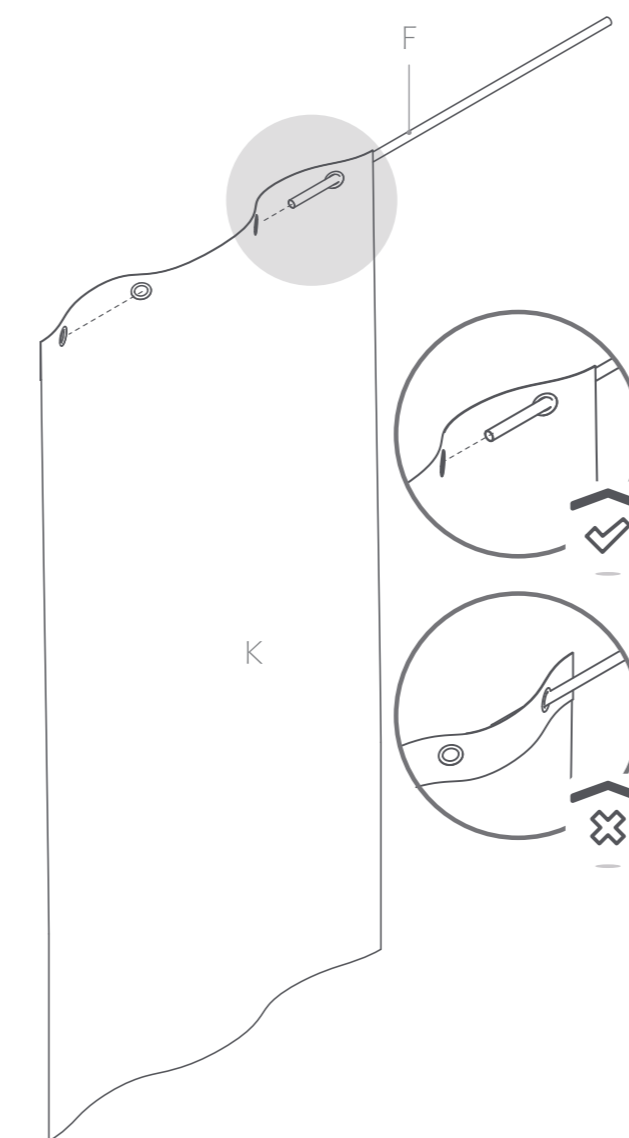

11 Coloca cortina



12 Asegura cortina

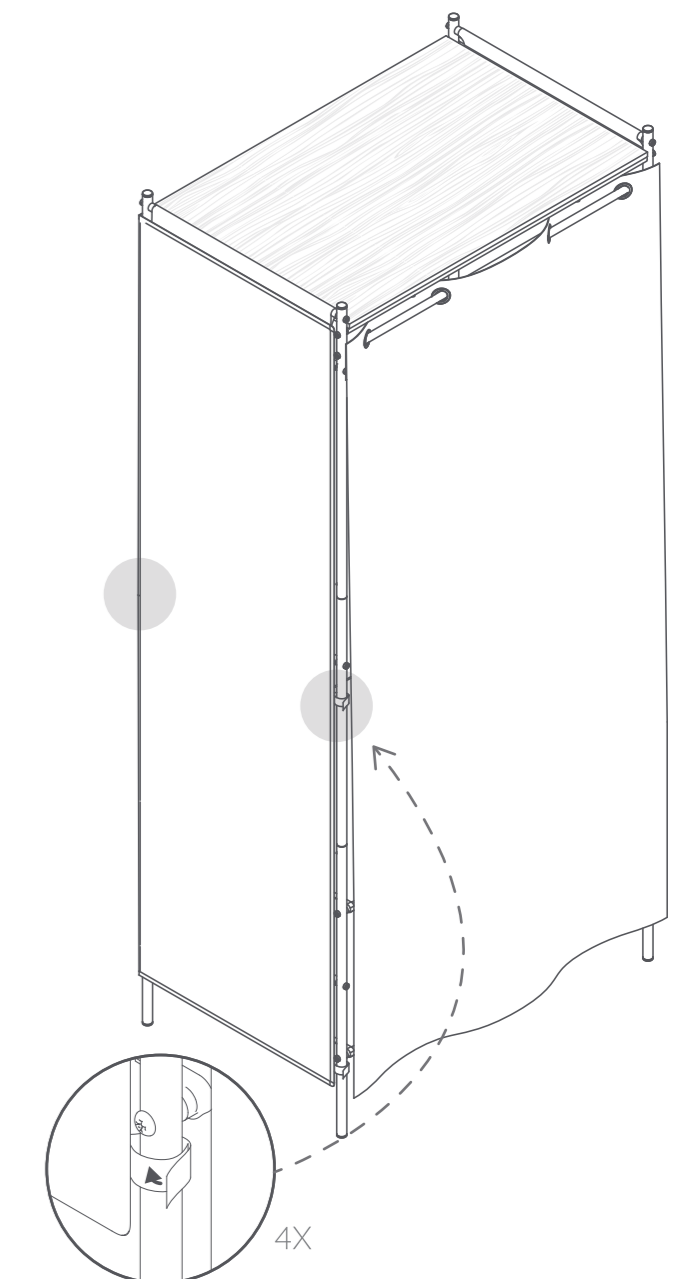

Sujeta con los velcros por ambos lados.