

Ver instructivo para armar adecuadamente

Guía Rápida

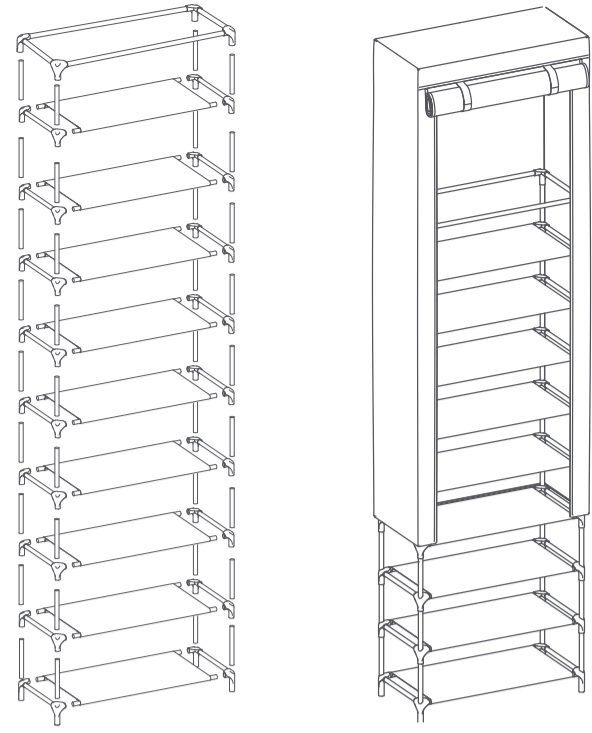

1 Identifica

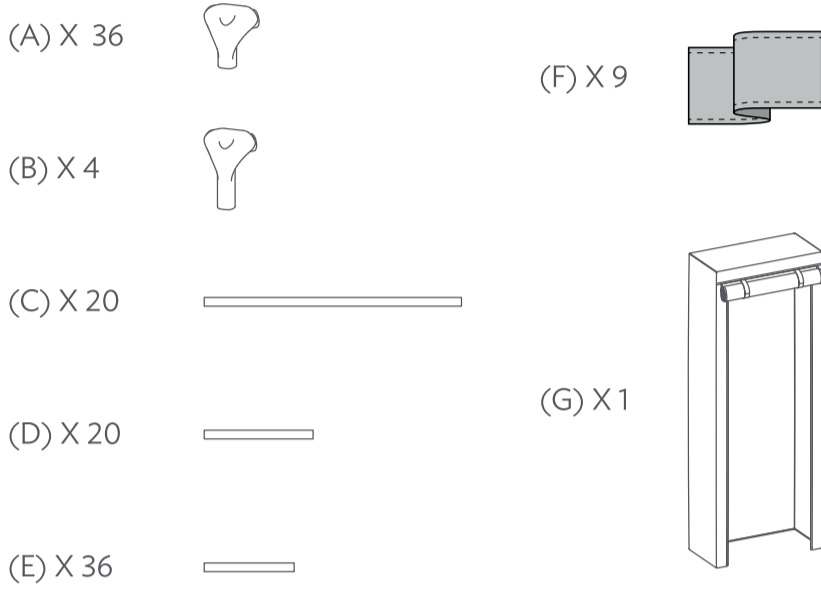

2 Arma repisas

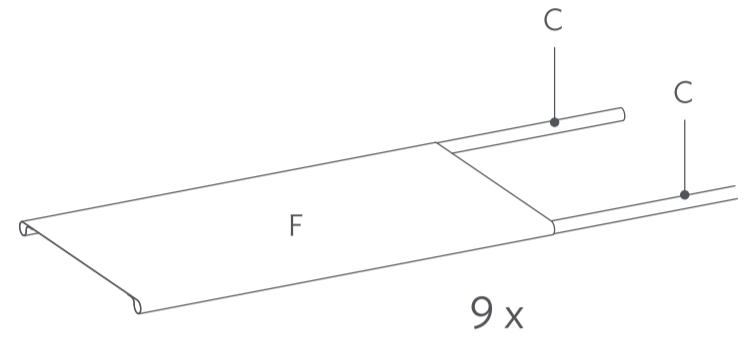

3 Arma repisa inferior

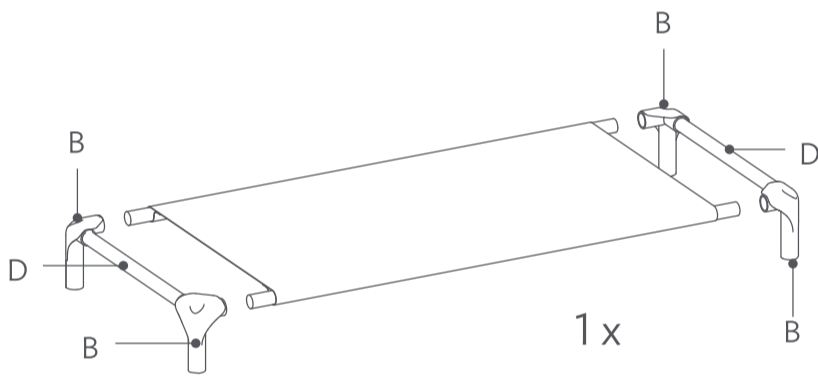

4 Refuerza repisas restantes

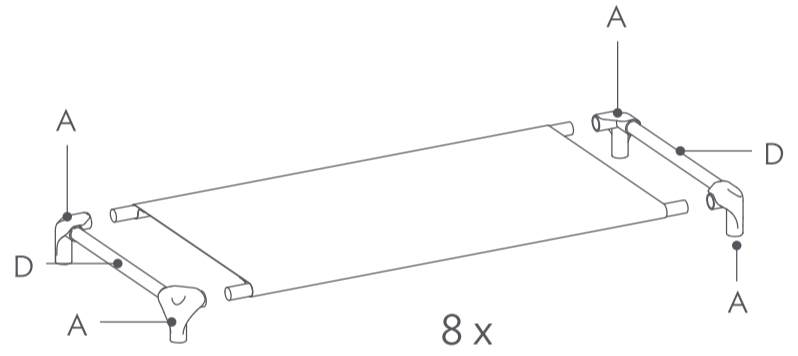

5 Une repisas

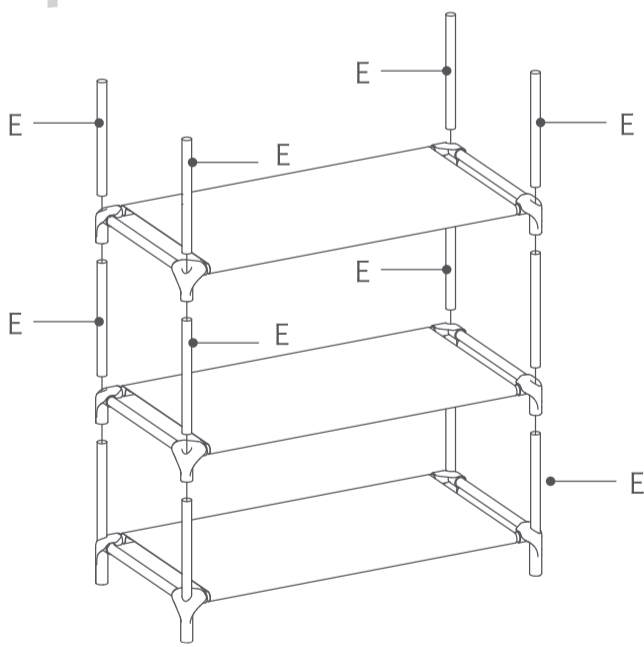

- Comienza con la repisa inferior, inserta los tubos E y continua con el resto de las repisas.

6 Arma estructura superior

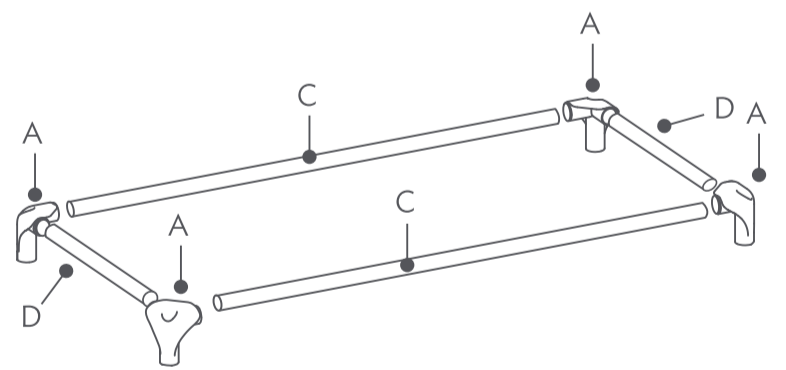

7 Ensambla parte superior

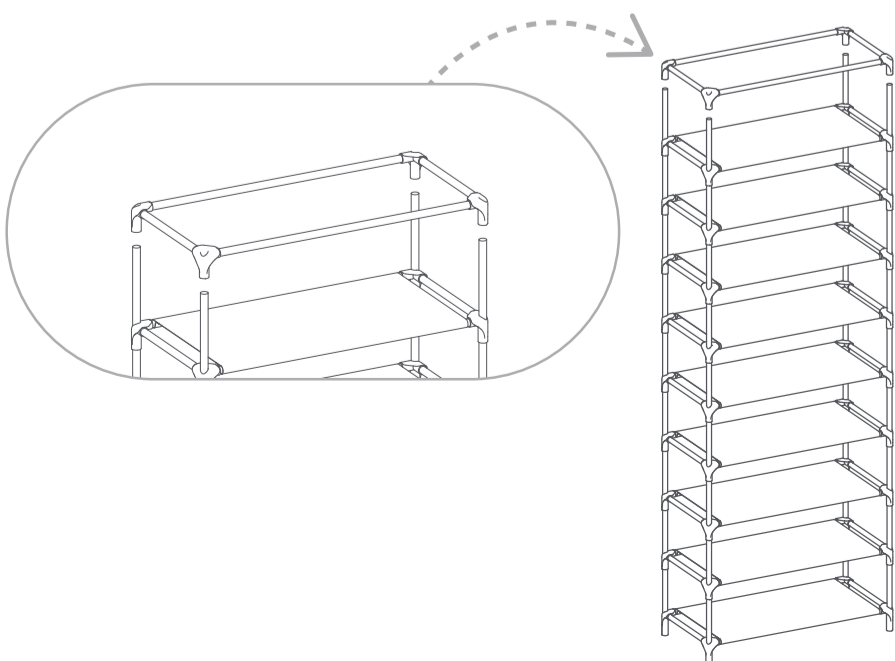

8 Coloca cubierta

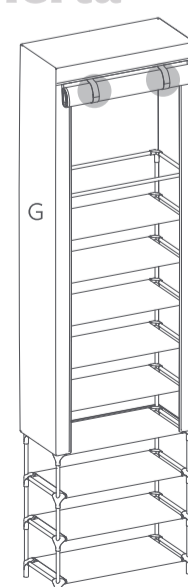

- Enrolla la puerta de la cubierta y sujeta con los velcros, desenrolla para mantener el interior oculto.
- Sujeta la cubierta anudando los cordones internos.
- Soporta: 3 kg por repisa.