

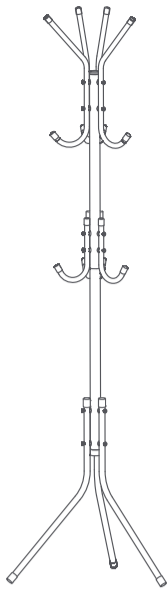

24384

Perchero Resist 12

Perchero

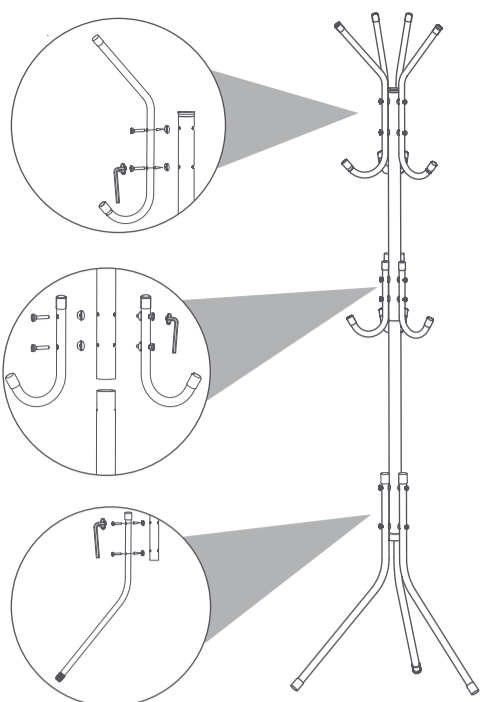

Ver instructivo para su uso adecuado.

Guía Rápida

Peso óptimo 10 kg distribuidos.

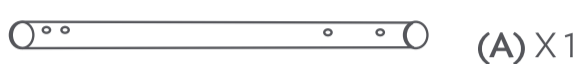
1 Identifica

(A) X1

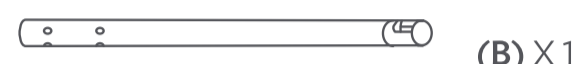

(B) X1



(C) X4



(D) X4



(E) X3

(F) X16
Chicos(G) X6
Grandes

(H) X22



(I) X16



(J) X6



(K) X1

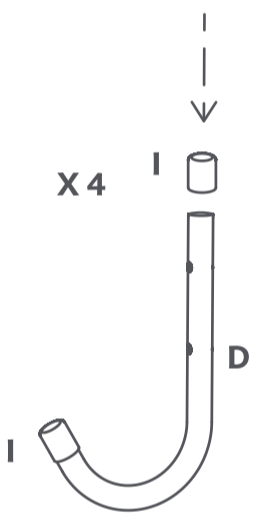
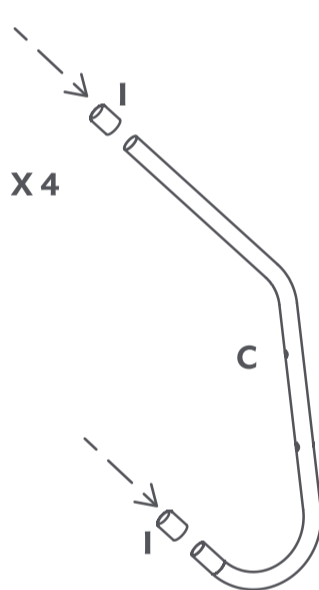
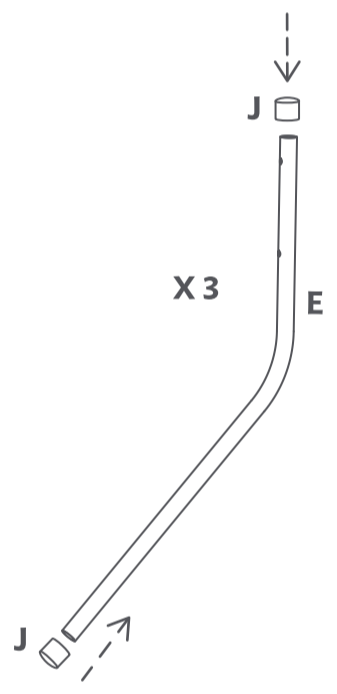
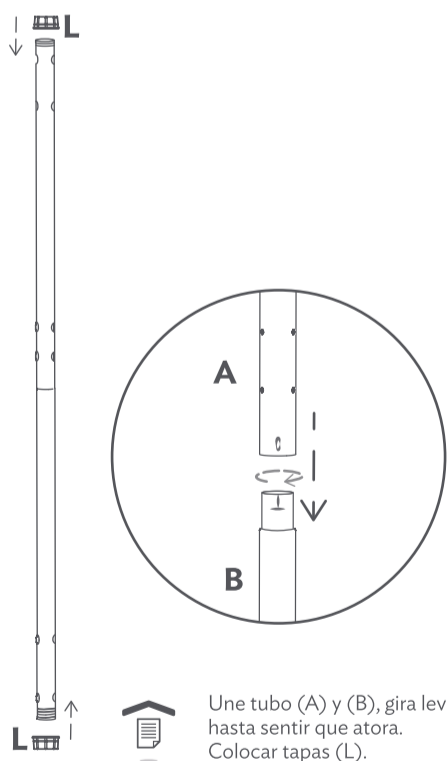

(L) X2

2 Arma ganchos medios**3 Arma ganchos superiores****4 Patas****5 Arma estructura**

Une tubo (A) y (B), gira levemente hasta sentir que atora. Colocar tapas (L).

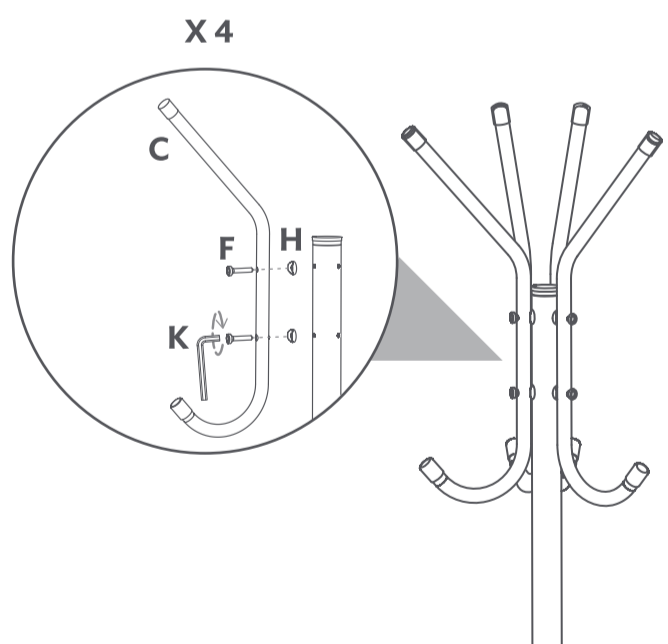
6 Ensambla parte superior

Coloca los topes (H), entre los ganchos (C) y el tubo (A). Fija con los tornillos (F) utilizando la llave (K).

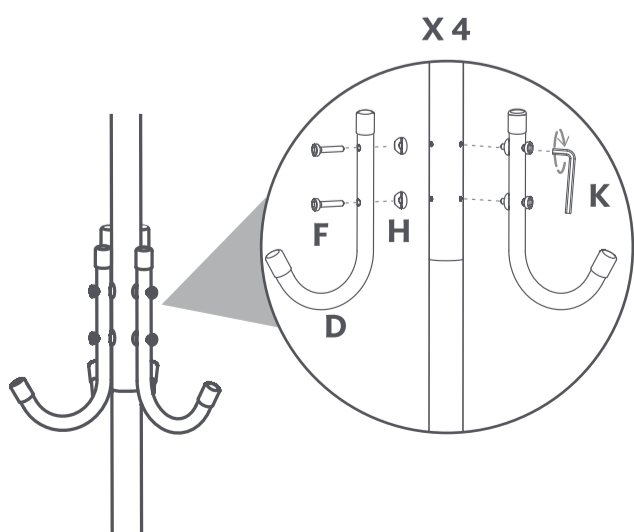
7 Ensambla parte inferior

Coloca los topes (H), entre los ganchos (D) y el tubo (A). Fija con los tornillos (F) utilizando la llave (K).

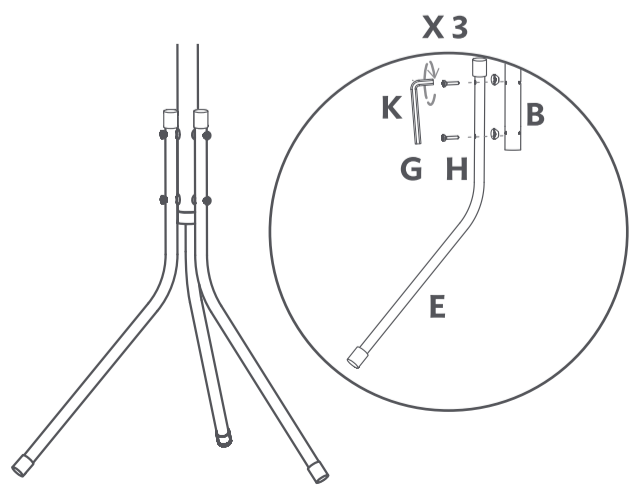
8 Ensambla patas

Coloca los topes (H), entre las patas (E) y el tubo (B). Fija con los tornillos (G) utilizando la llave (K).