

Ver instructivo para su uso adecuado

## Guía Rápida

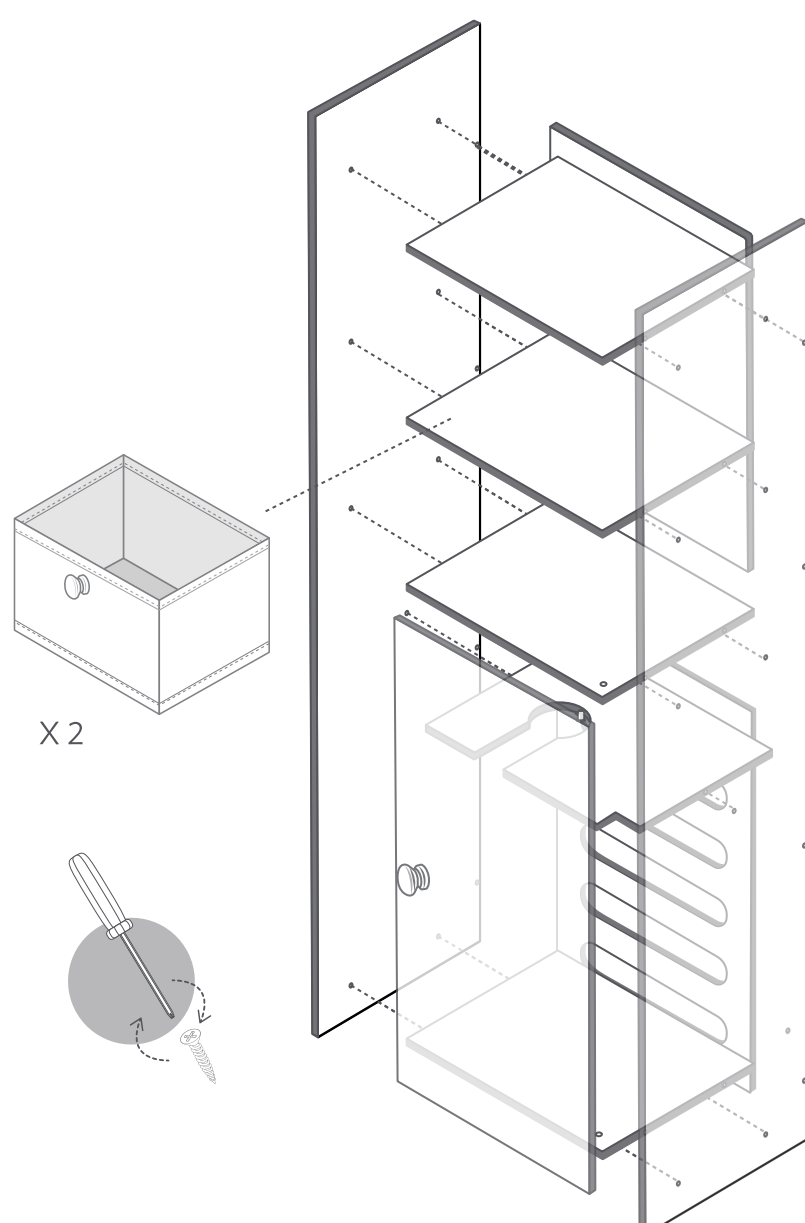

## 1 Identifica

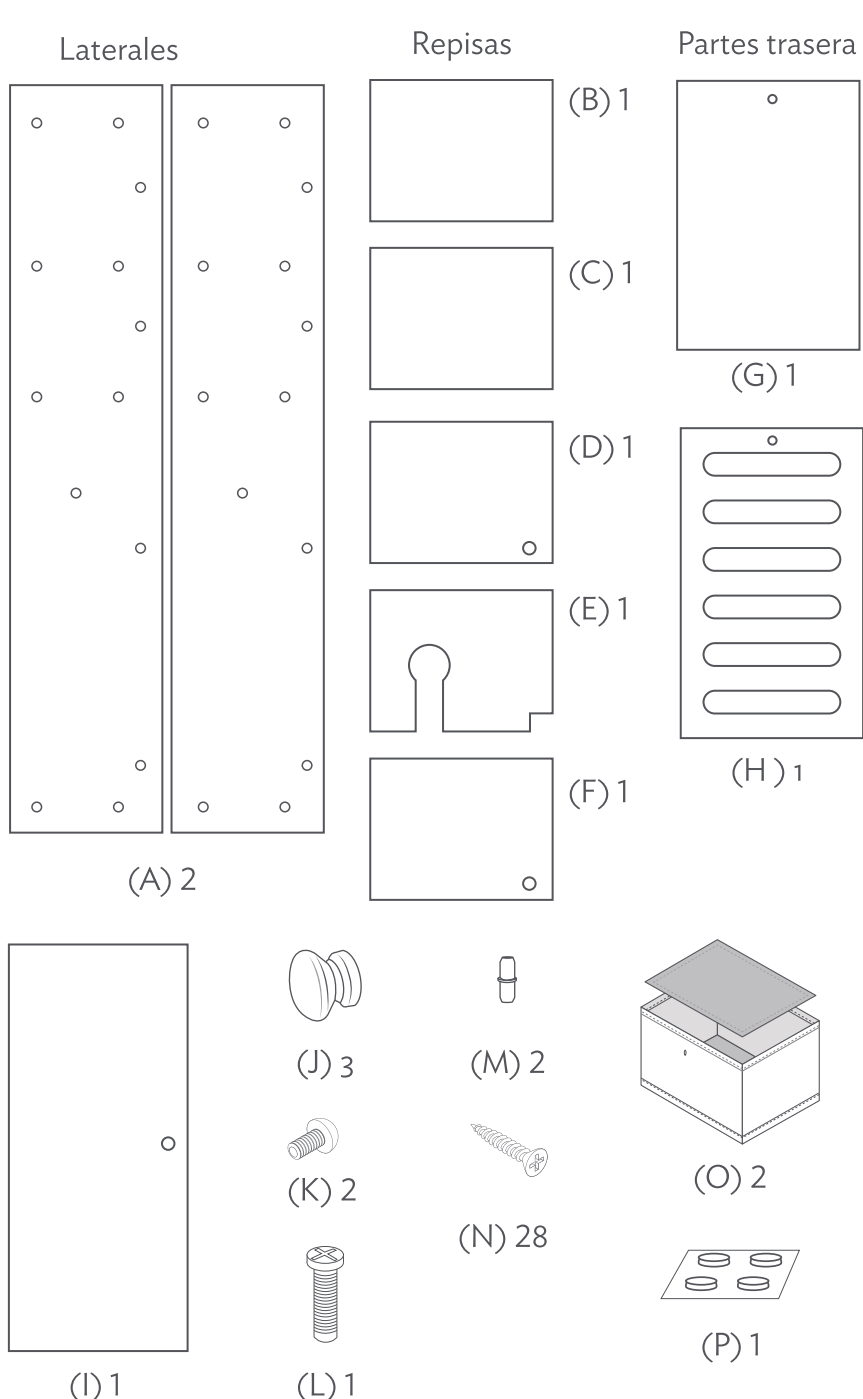

## 2 Coloca repisas

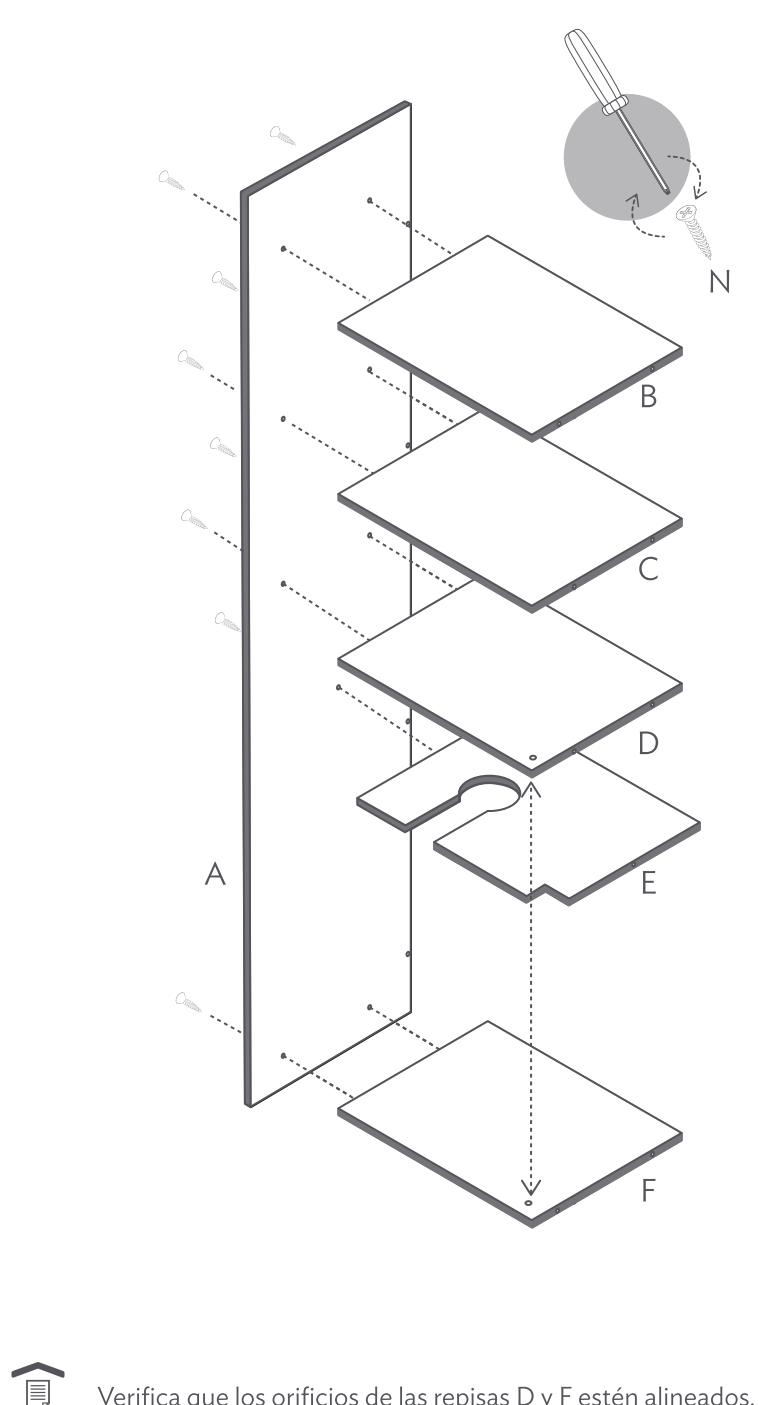

Verifica que los orificios de las repisas D y F estén alineados.

## 3 Coloca piezas posteriores

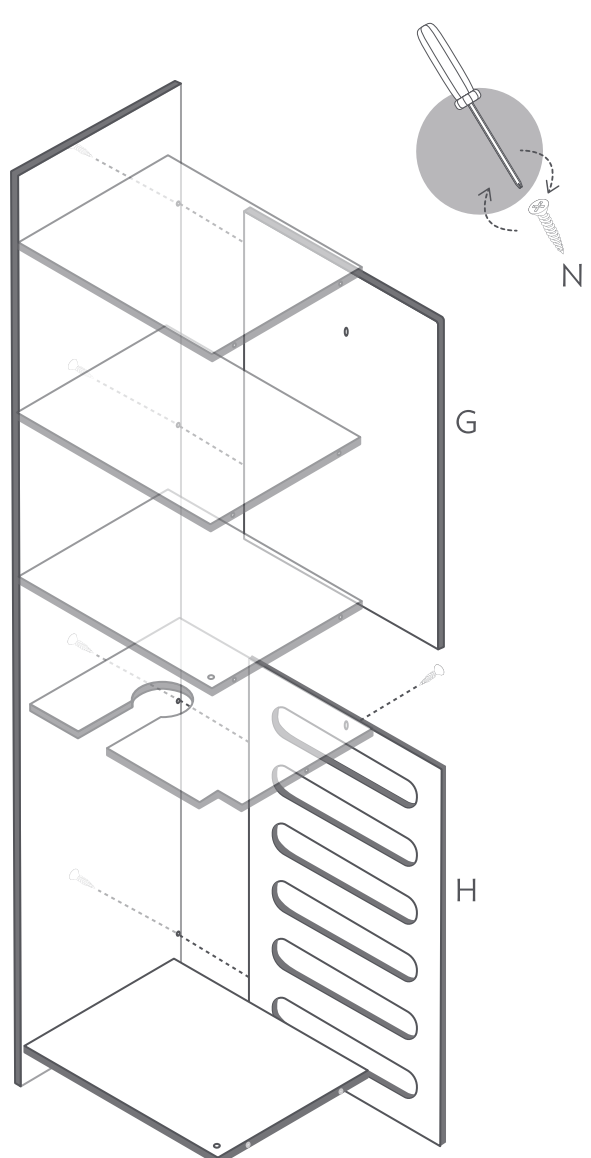

## 4 Coloca puerta

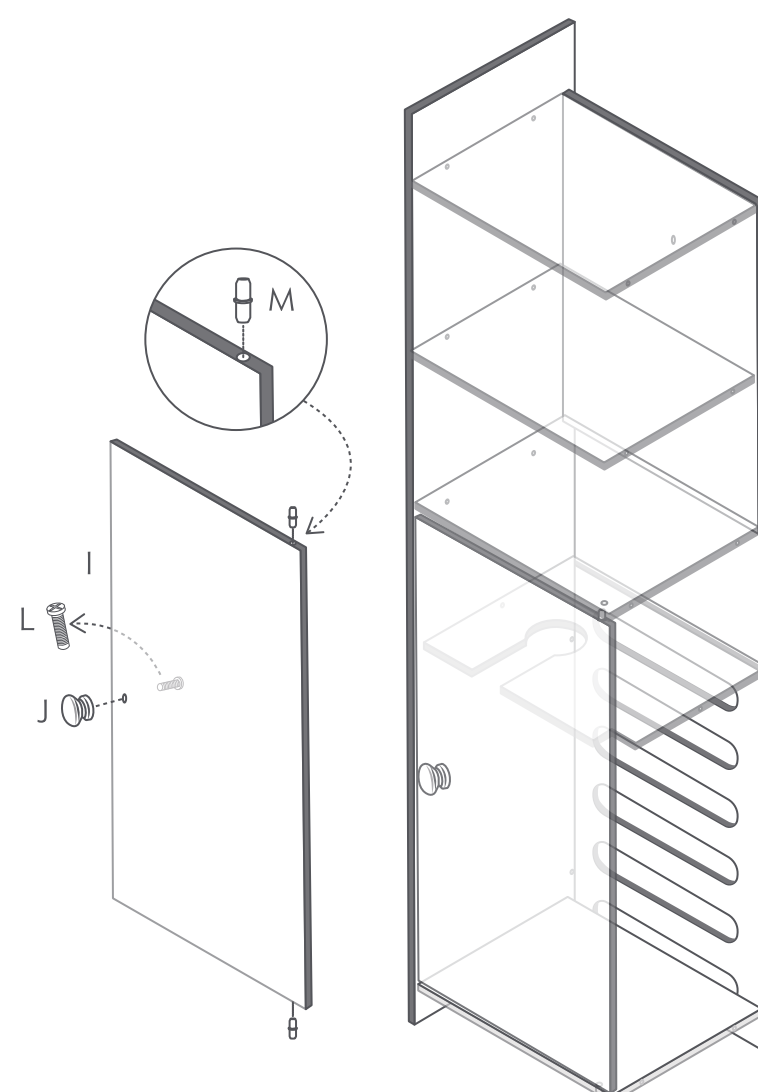

## 5 Coloca lateral

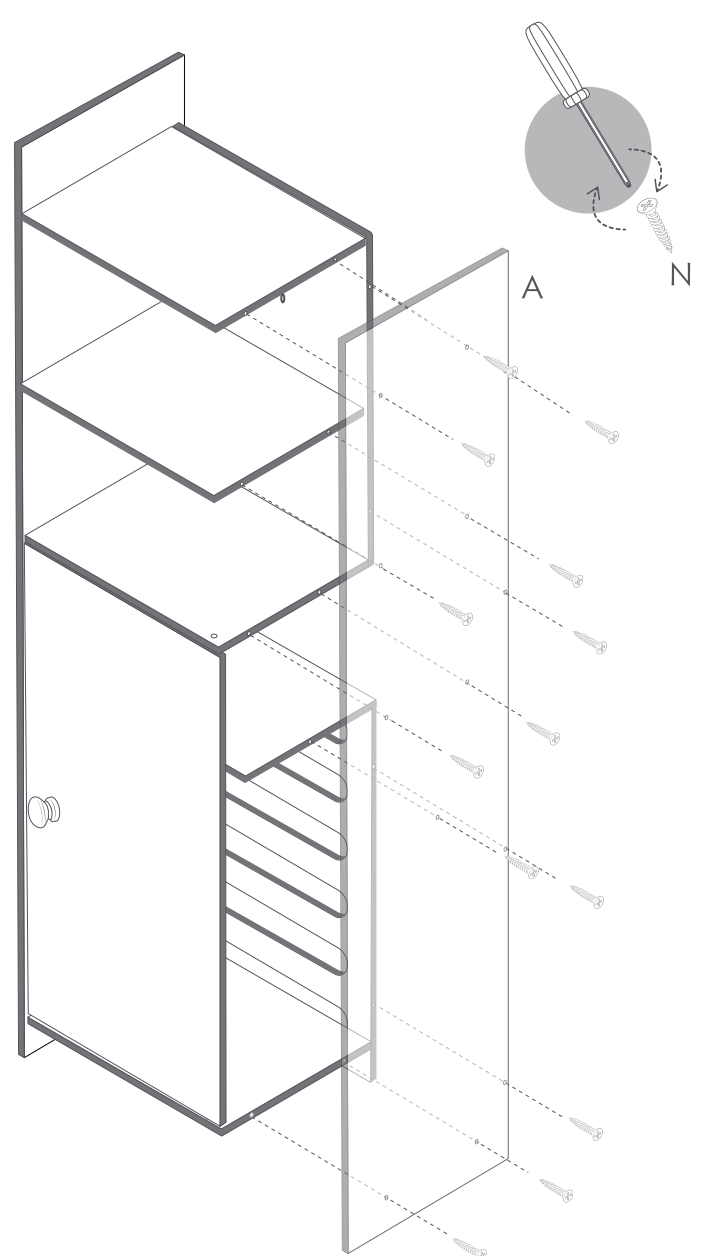

## 6 Arma y coloca canastas

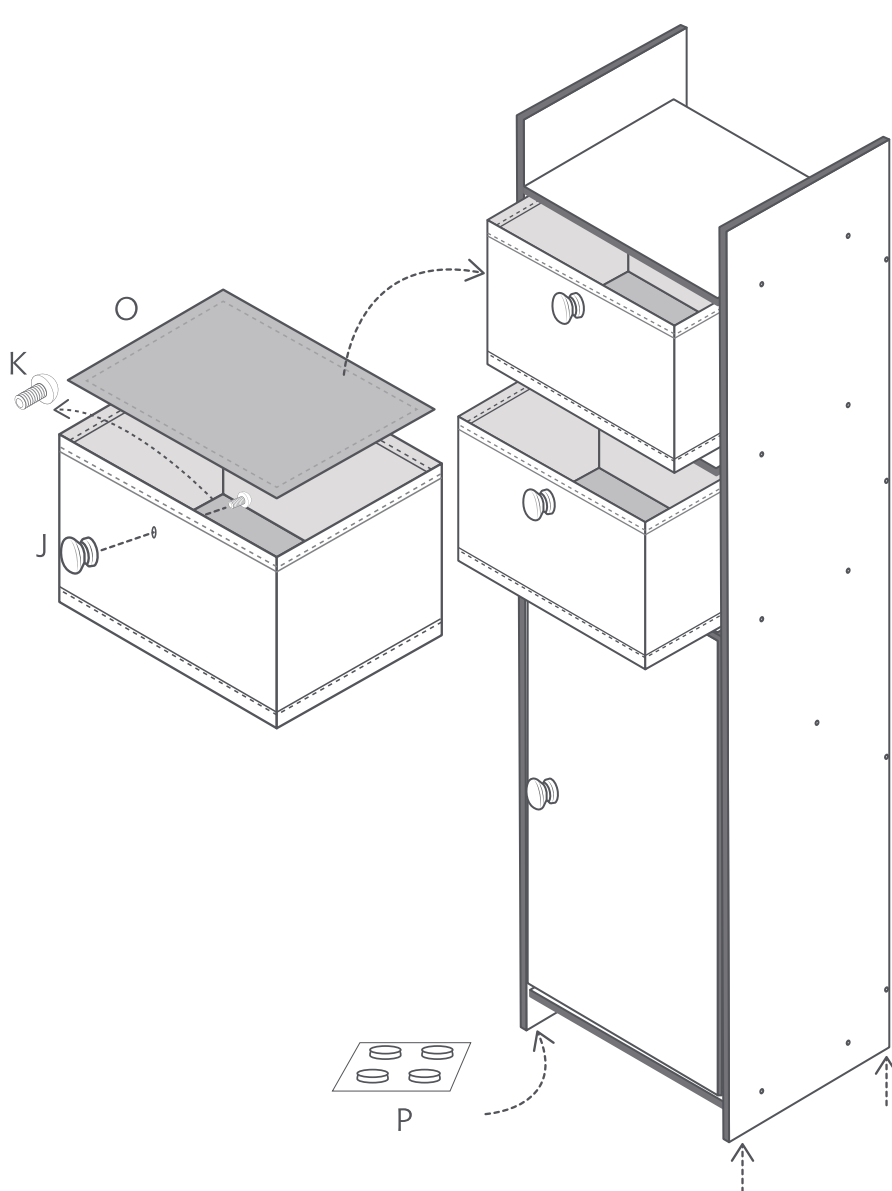

Peso óptimo de carga: 30 kg distribuidos / 3 L canasta.  
 Coloca los antideslizantes P en las 4 esquinas de la parte inferior del mueble.