

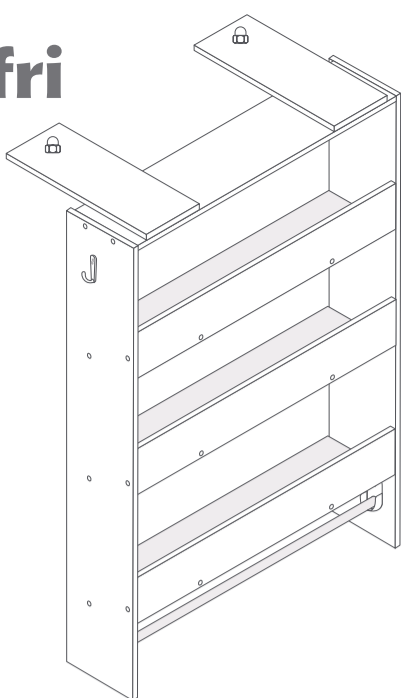

24808

# Organi Refri Bambú

Repisa



Ver instructivo para armar adecuadamente.

## 1 Identifica

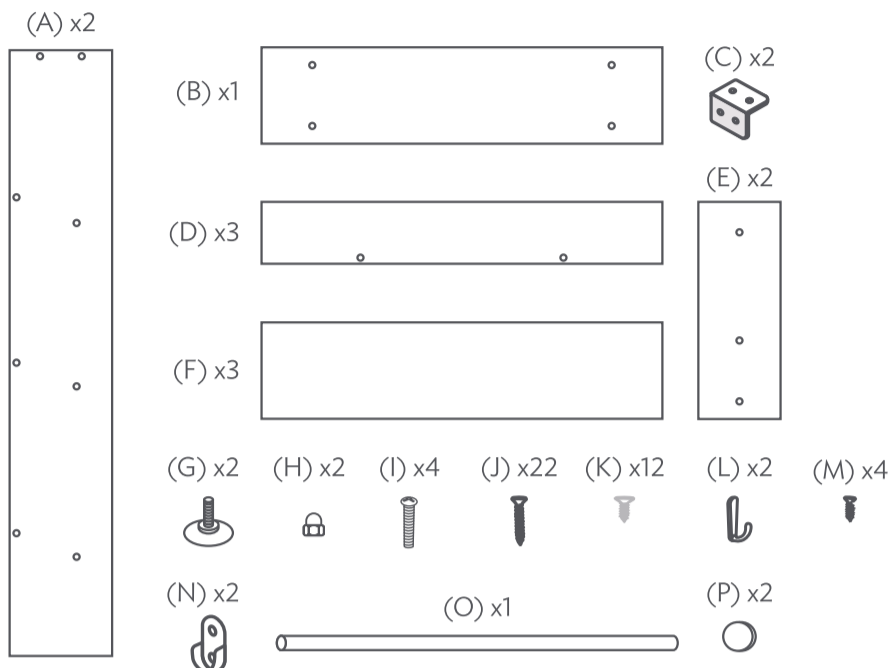

## 2 Arma estructura

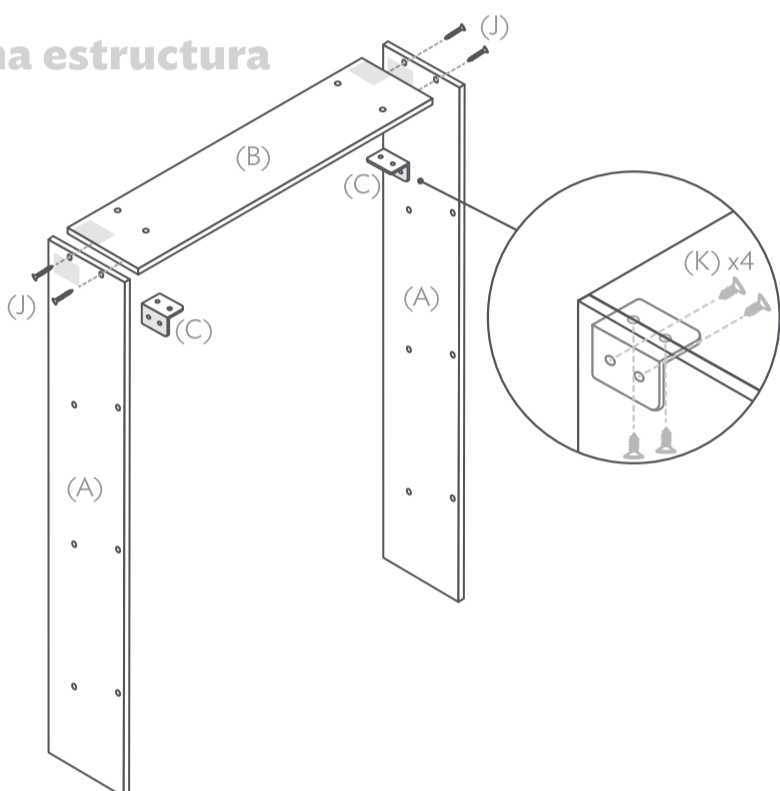

## 3 Arma repisas

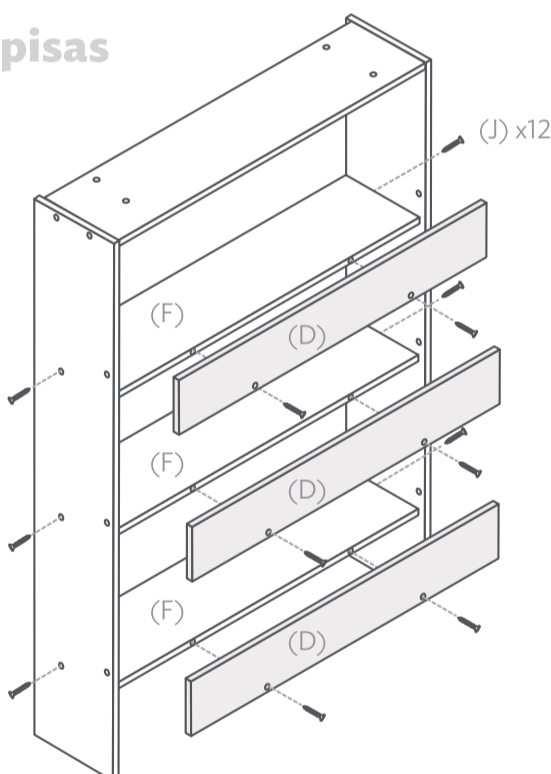

## 4 Ensambla

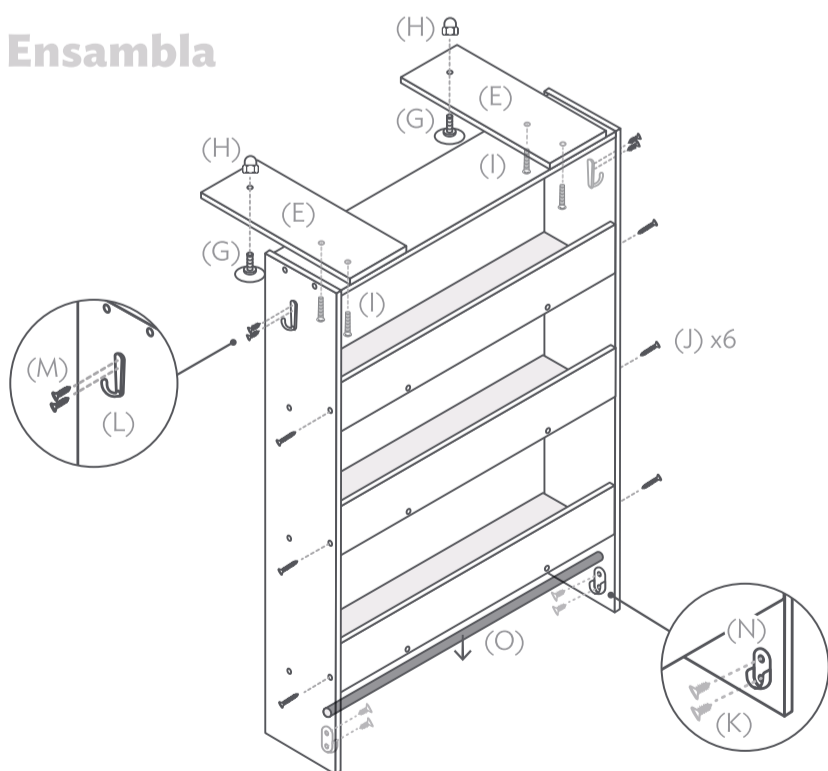

• Apoya la pieza (O) dentro de las piezas (N).

## 5 Coloca

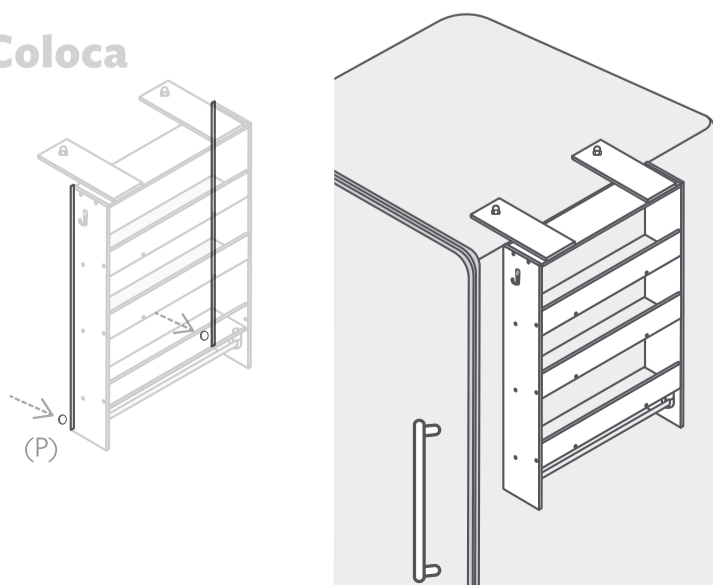

• Pega las gomas (P) en la parte inferior del borde en ambas piezas (A), para que la repisa quede firme en su lugar.

• El peso óptimo que soporta la repisa es de 5 kg.