

Bloc 2 prises électriques + USB

USB + 2 electrical plugs block

Instructions de montage
Mounting instructions

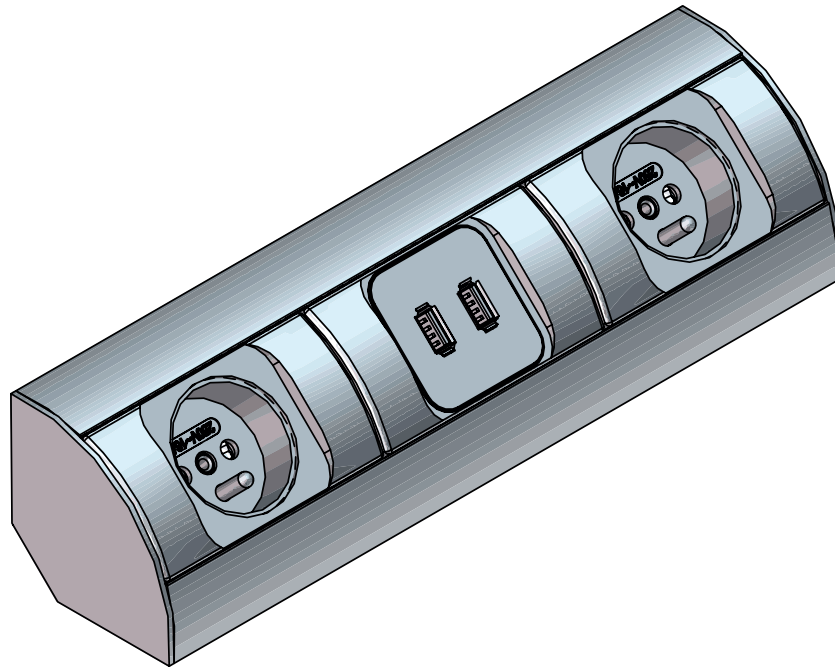

Quincaillerie / Hardware

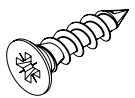

Non fournies /
Not supplied



Ø 3,5 mm A

--	--	--	--	--	--	--	--	--	--

Nécessaire / Necessary

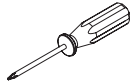
 x 1	 15 min				
--	---	---	--	--	--

Références / References

B2PUSB	09494724



FR

Cet appareil
et ses accessoires
se recyclent



The item should not be disposed of
with household waste. Please take it
to a collection point or an approved
centre to ensure that it is recycled.

Points de collecte sur www.quefairedemesdechets.fr
Privilégiez la réparation ou le don de votre appareil !



FR

ÉLÉMENTS D'EMBALLAGE
À SÉPARER ET À DÉPOSER
DANS LE BAC DE TRI



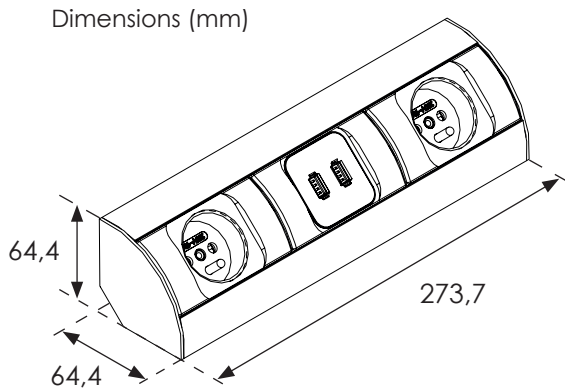

Références / References	B2PUSB
Alimentation / Power supply	230 V ~ 50 Hz
Puissance de sortie / Output power	1500 W
Prises USB / USB slots	5V / 2A
Indice de protection / Index protection rating	IP 20
Isolation électrique / Electrical insulation	Classe 1 / Class I



1 Branchement électrique / Electrical connection



L'appareil doit être installé par un électricien qualifié et câblé conformément aux exigences nationales en vigueur. / The device shall be installed by a qualified electrician and wired in accordance with the national requirements in force.

1 Coupez l'alimentation générale / Cut off the general power supply

Conformément à la norme NF C 15-100, raccordez l'appareil à l'alimentation électrique par l'intermédiaire d'un boîtier de raccordement non fourni (IPX4). / According to standard NF C 15-100, connect the device to the power supply through a connection box not supplied (IPX4).

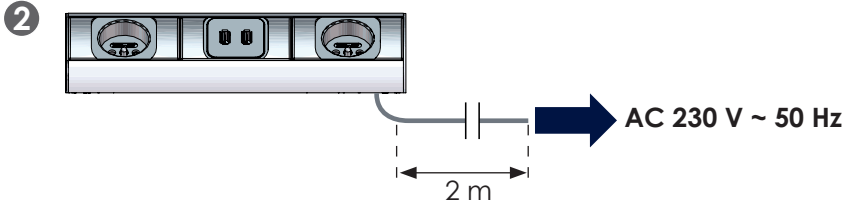

2 Montage / Assembly

