

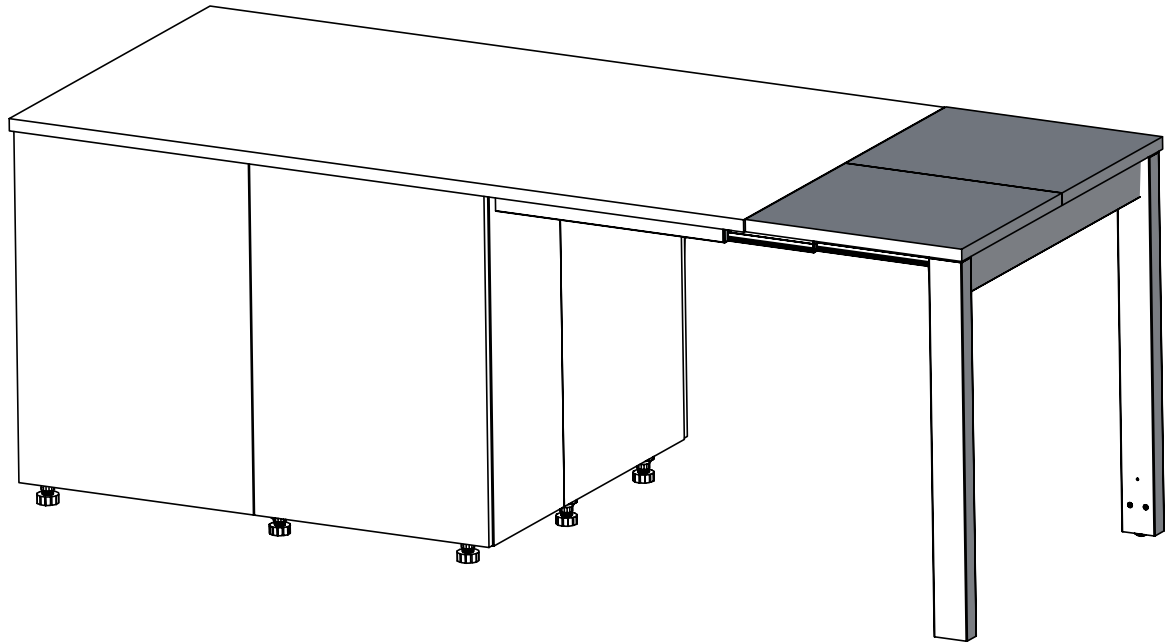





# Rallonge de plan de travail

## Worktop extension



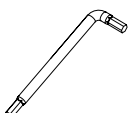

Instructions de montage  
Mounting instructions



### Quincaillerie / Hardware

<b>x6</b> 	<b>x3</b> 	<b>x4</b> 	<b>x4</b> 	<b>x6</b> 	<b>x8</b> 				
Ø4x70 A	Ø3 / Ø4 / Ø5 B	Ø6x16 C	Ø6x18 D	E	Ø4x25 F				

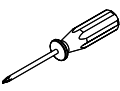
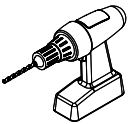
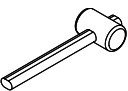
### Nécessaire / Necessary

 x 1	 45 min								
--	---	---	---	---	---	--	--	--	--

### Références / References

EP3C1	EP4C1		
-------	-------	--	--

1

Vis de la couleur du mécanisme / Screws with the color of the mechanism

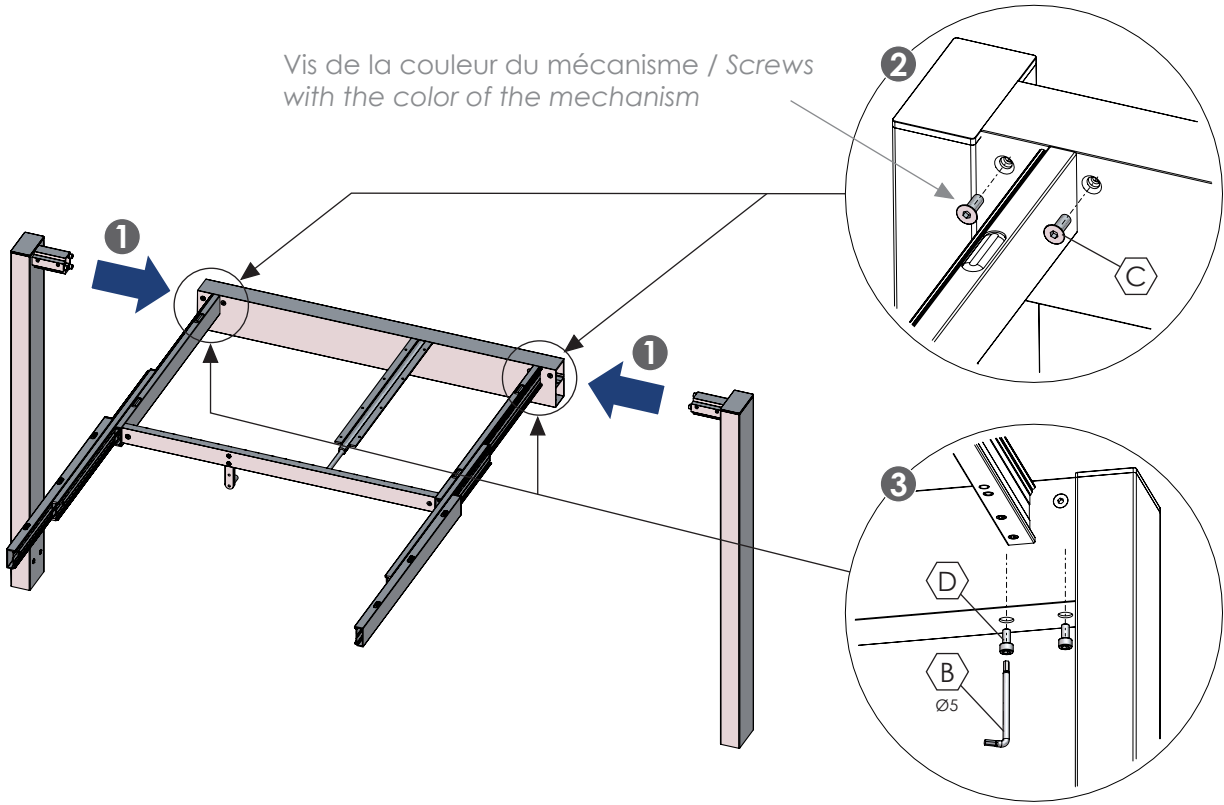

2

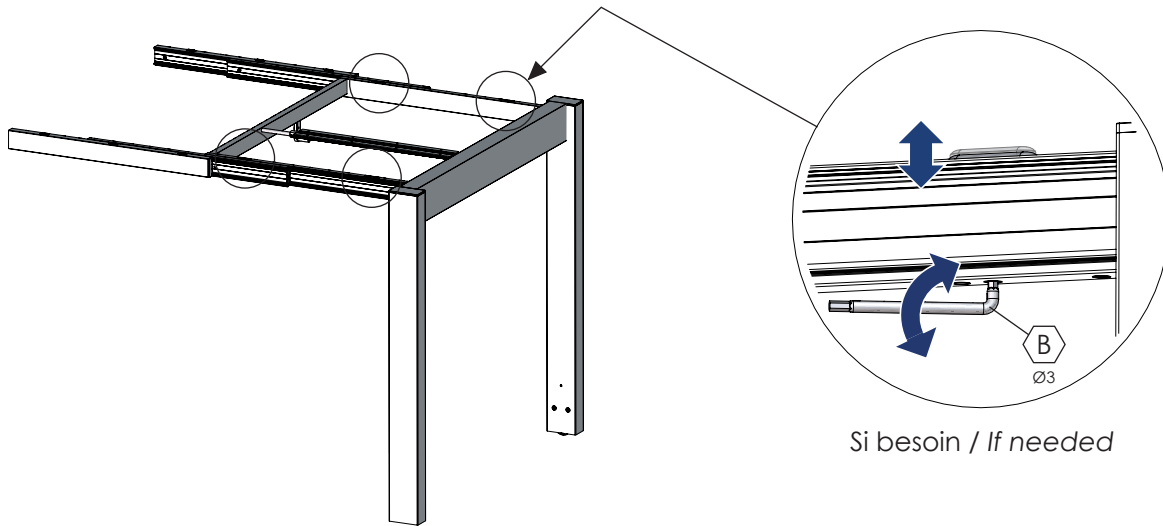

3

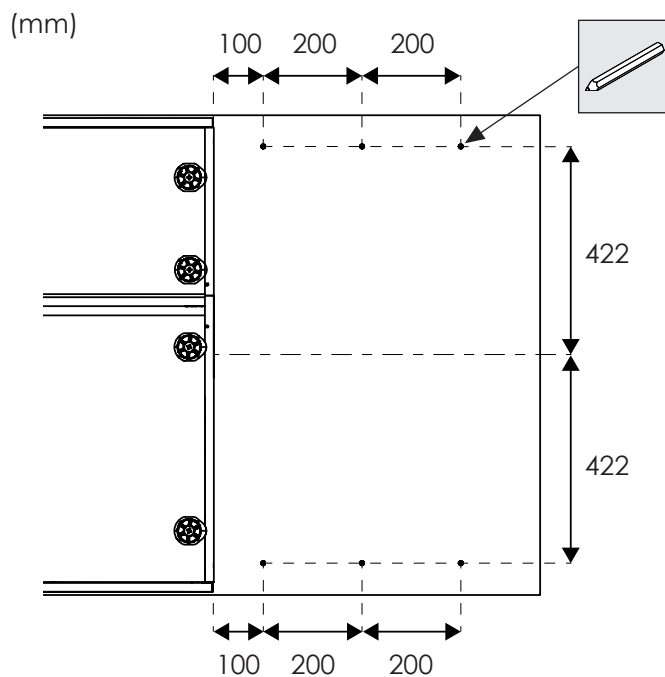
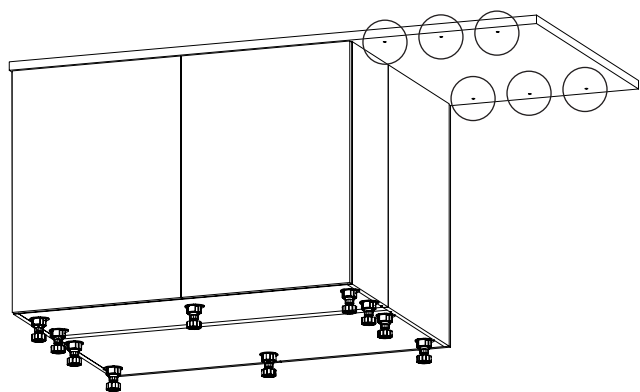

4

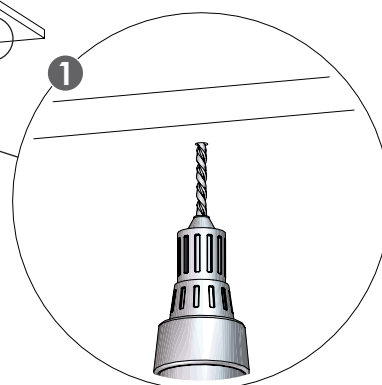
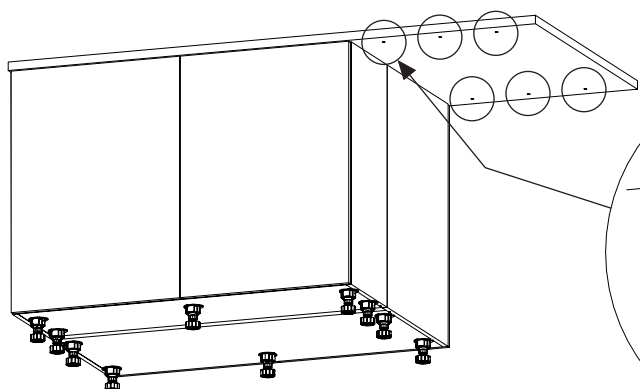

Ø10  
Profondeur / Depth 10 mm

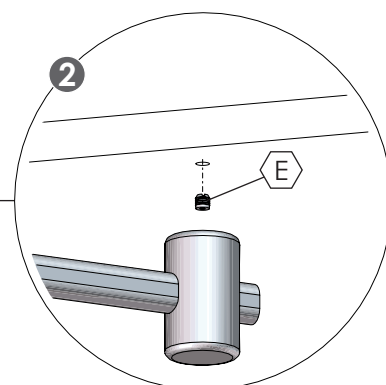

**Astuce / Tip :**

Mettez du ruban adhésif sur la perceuse en laissant dépasser la mèche de 10 mm / Put adhesive tape on the drill by protruding the bit 10 mm

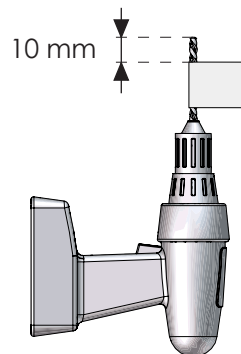

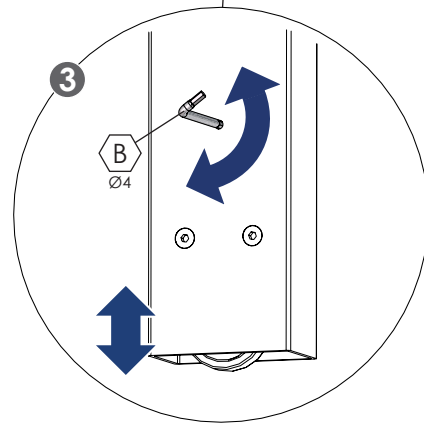
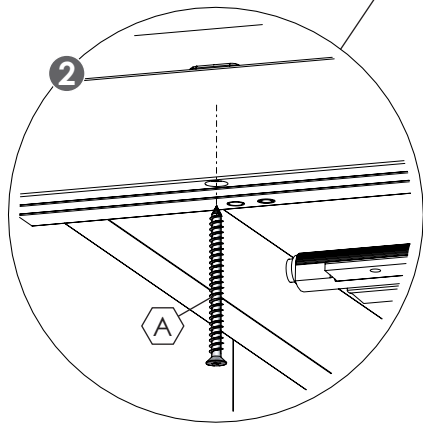
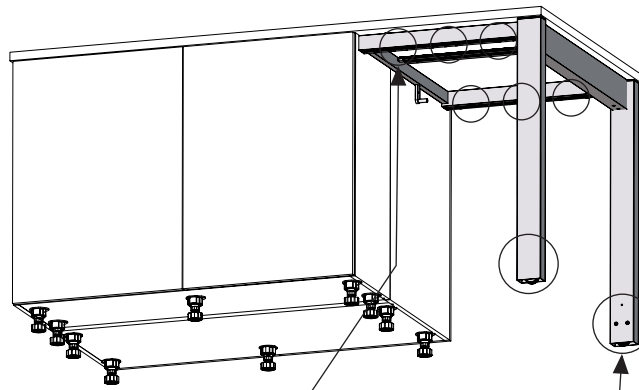
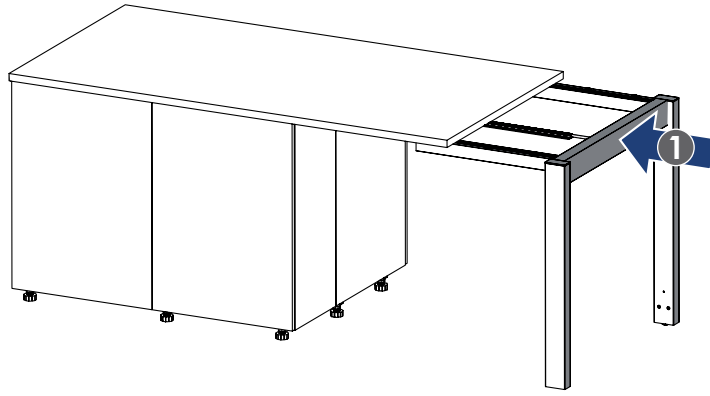

Si besoin / If needed

6

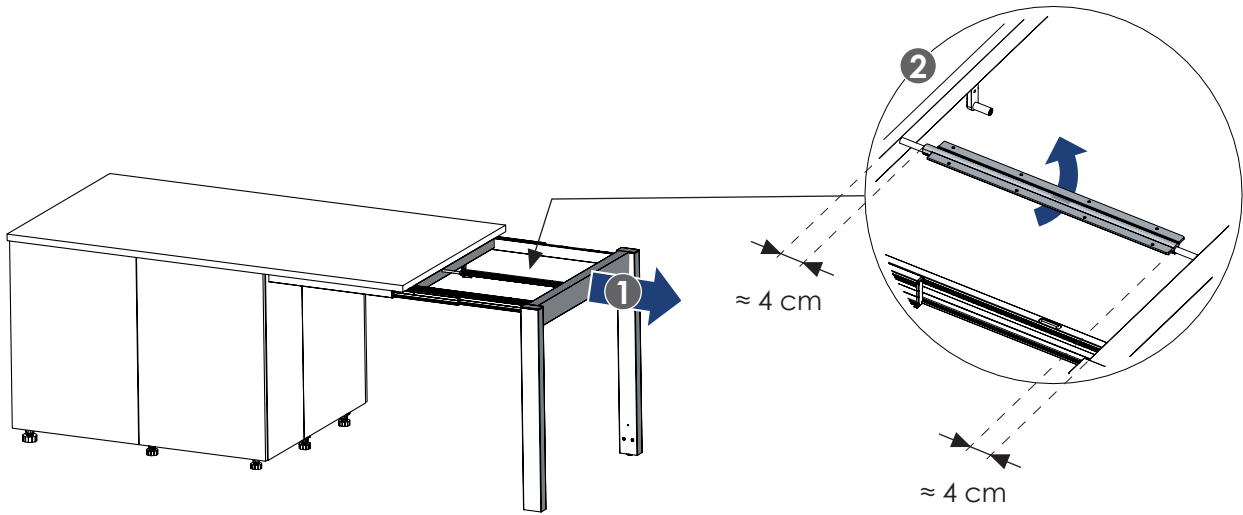

7

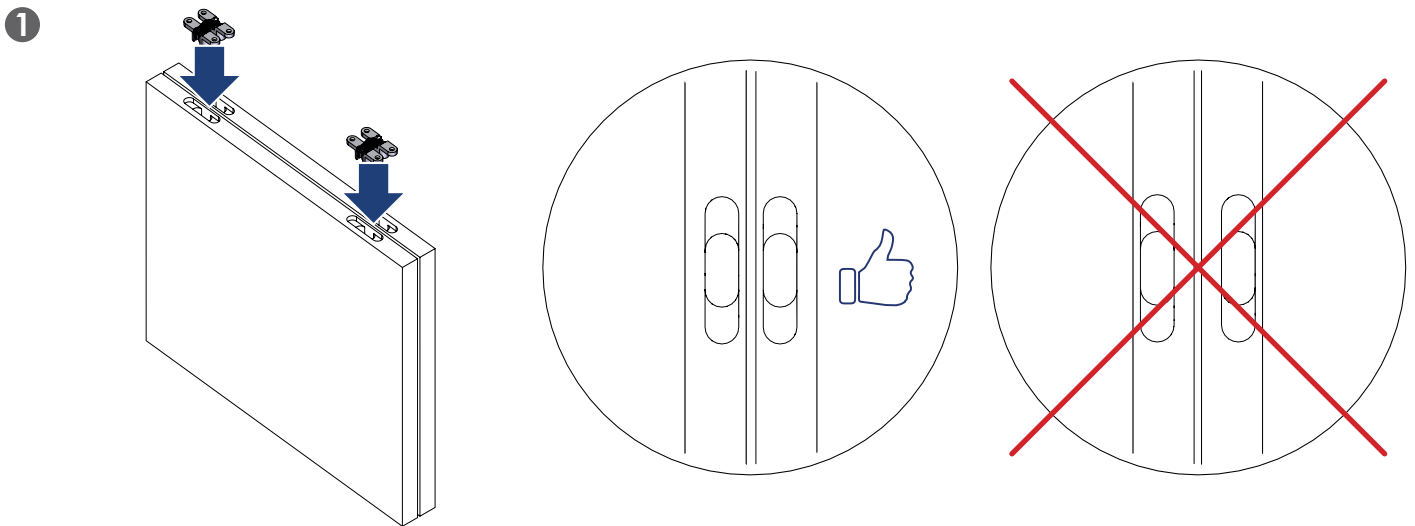

2

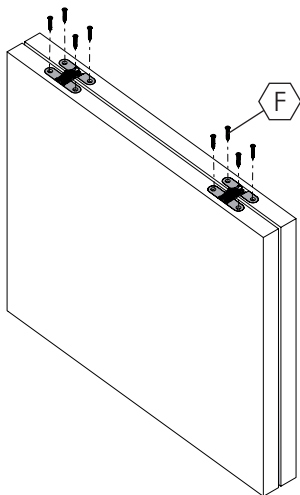

3

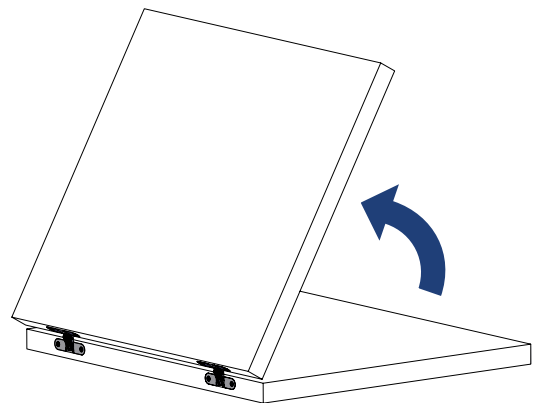

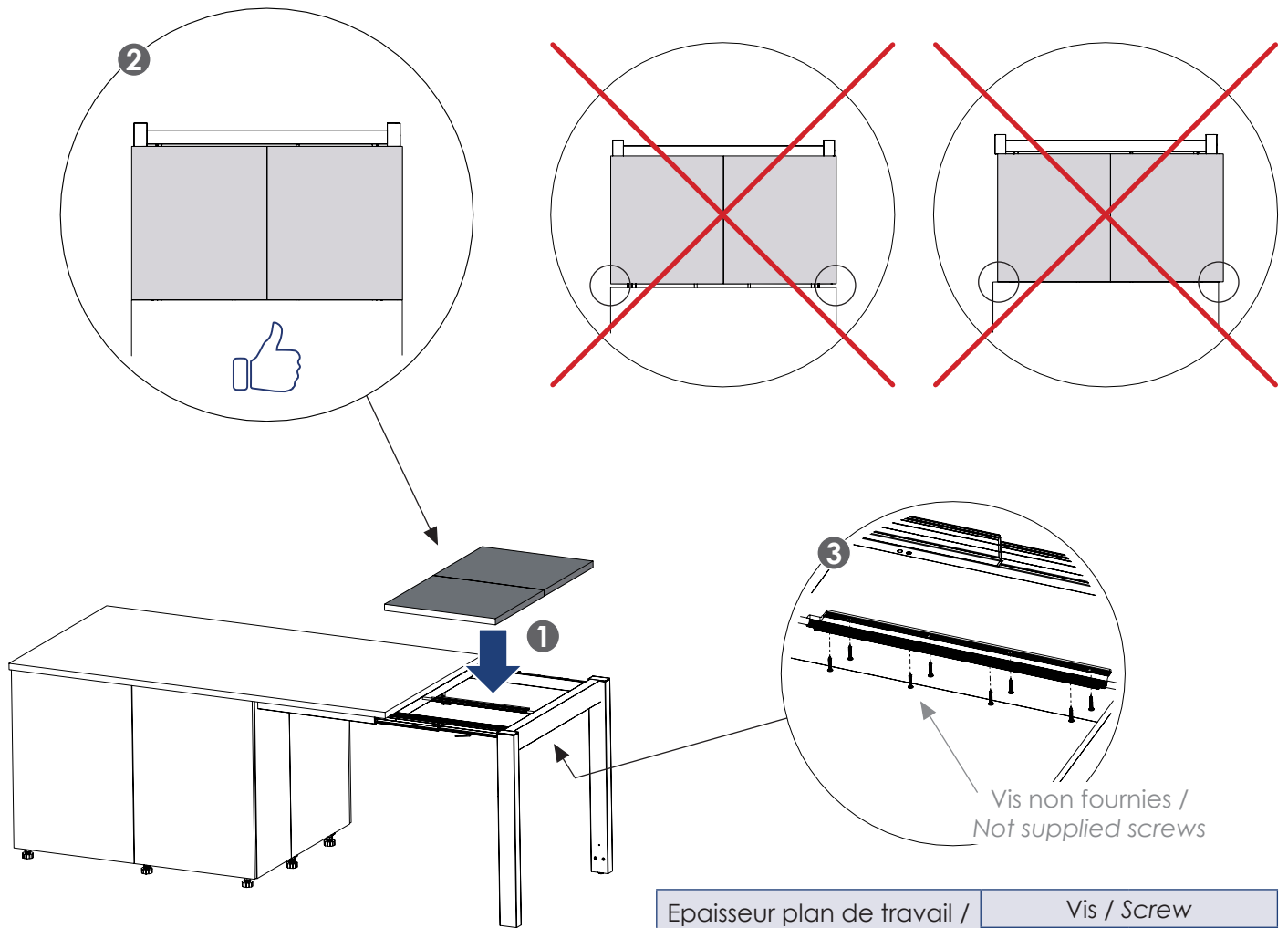

Epaisseur plan de travail / Worktop thickness	Vis / Screw	
	MIN	MAX
29 mm / 30 mm	Ø4 x 20	Ø4 x 25
39 mm / 40 mm	Ø4 x 30	Ø4 x 35

