

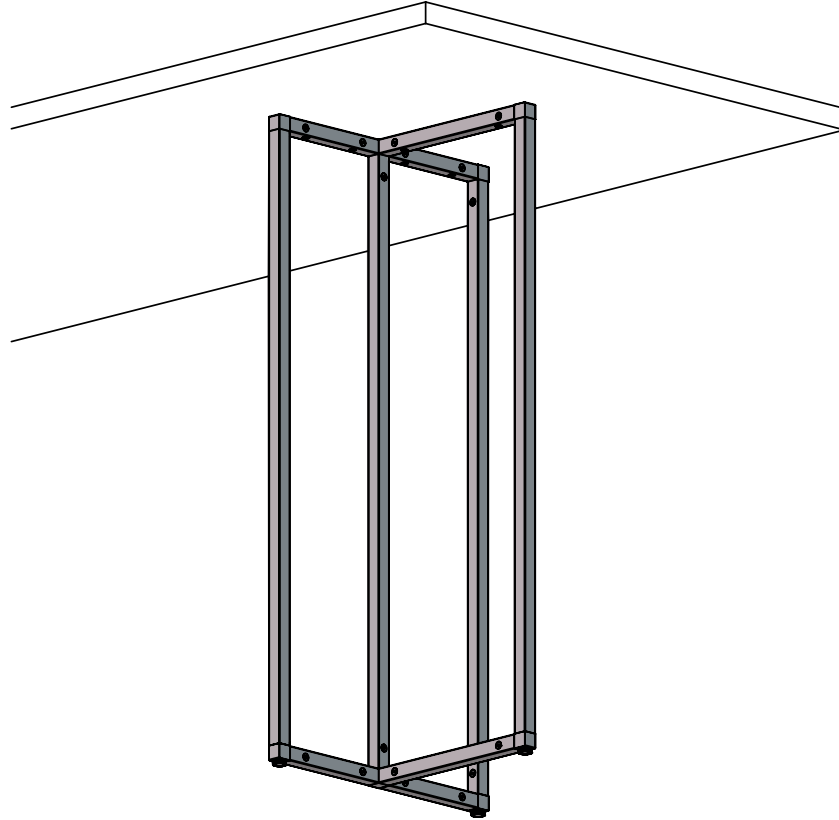

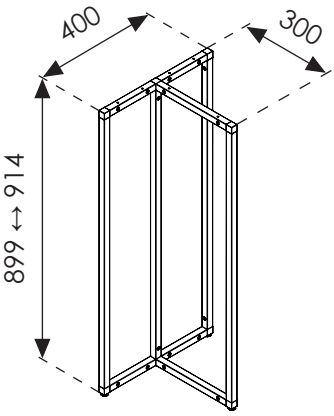

Piètement métal

Metal legs

Instructions de montage
Mounting instructions





<p>Dimensions (mm)</p>  <p>400</p> <p>300</p> <p>899 ↔ 914</p>	<p>Références / References</p> <p>P19M90NM</p>
	<p>Nécessaire / Necessary</p>  <p>x 1</p>  <p>30 min</p> 

Glossaire / Glossary

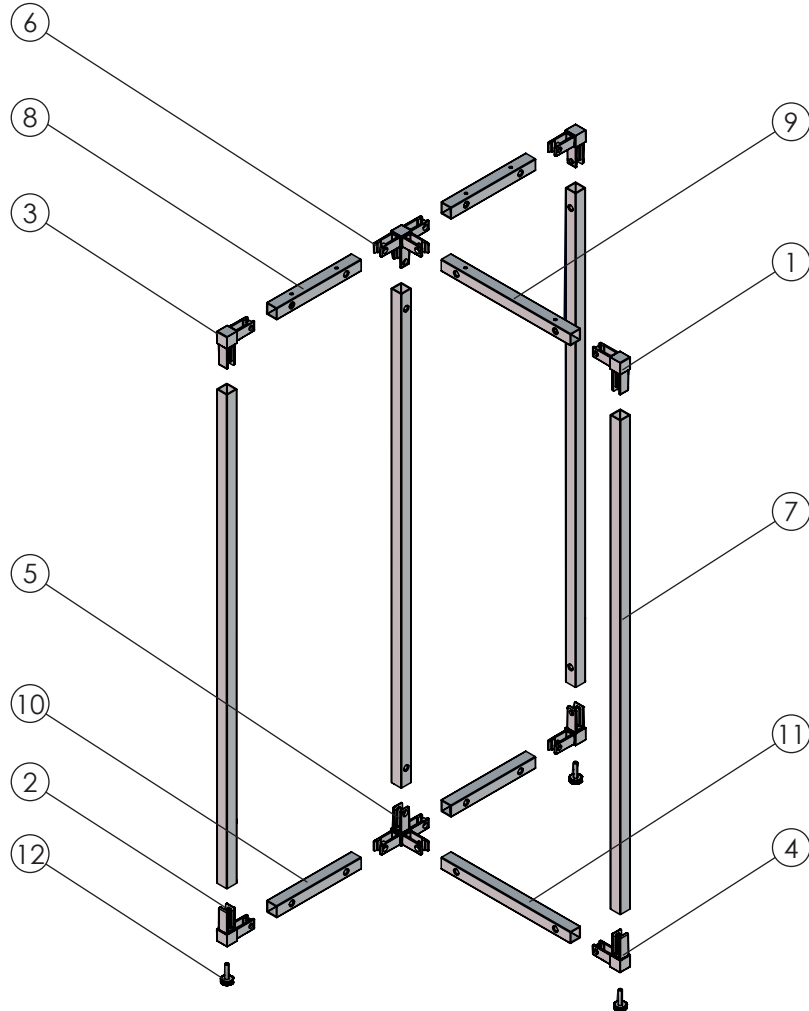

1	Angle A / Corner A	7	Tube pour hauteur / Tube for height
2	Angle A* (pour pied) / Corner A* (for leg)	8	Tube court en haut / Short tube at the top
3	Angle B / Corner B	9	Tube long en haut / Long tube at the top
4	Angle B* (pour pied) / Corner B* (for leg)	10	Tube court en bas / Short tube at the bottom
5	Angle C / Corner C	11	Tube long en bas / Long tube at the bottom
6	Angle D / Corner D	12	Pied / Leg



Quincaillerie / Hardware

									
A	B	C							

Outils non fournis / Not supplied tools

									
---	---	--	--	--	--	--	--	--	--



Angle A / Corner A

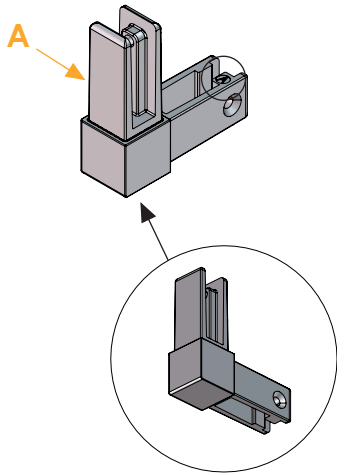

Angle B / Corner B

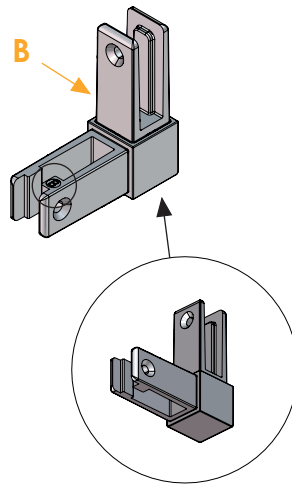

Angle C / Corner C

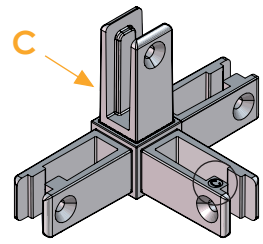

Angle A* (pour pied) /
Corner A* (for leg)

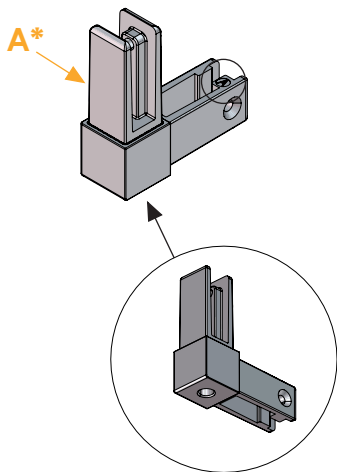

Angle B* (pour pied) /
Corner B* (for leg)

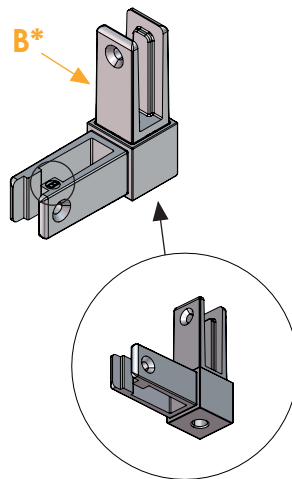

Angle D / Corner D

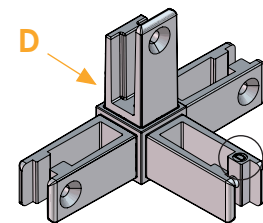

1

Partie basse / Lower part

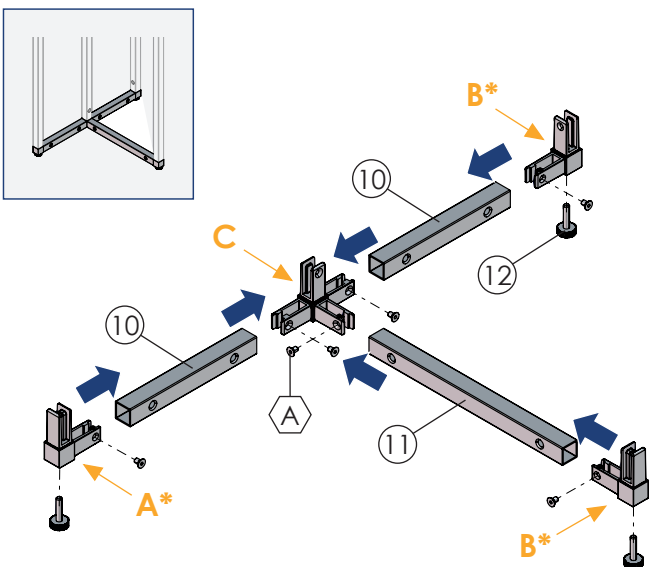

Partie haute / Upper part

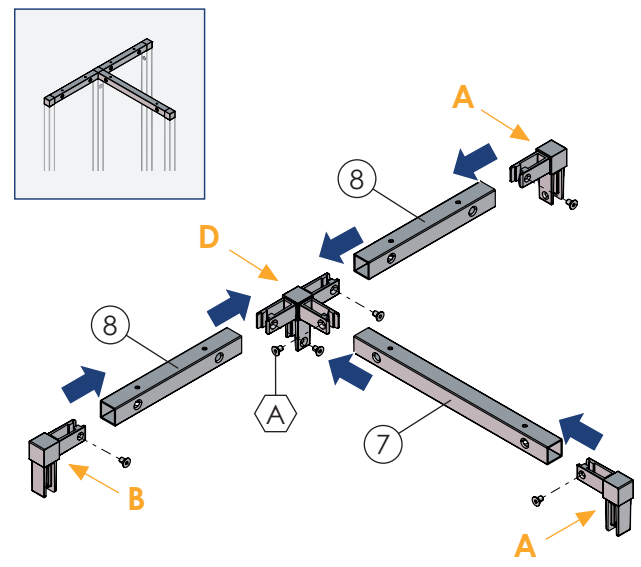

2

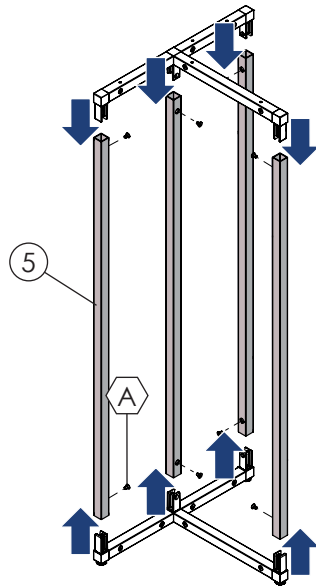

3

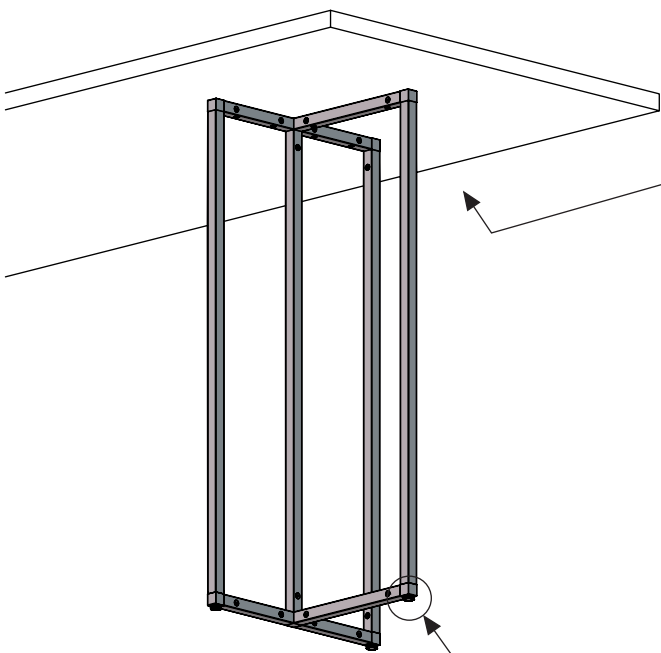

1 Si besoin, pré-percez le plan de travail /
If needed, drill pilot holes under the
worktop

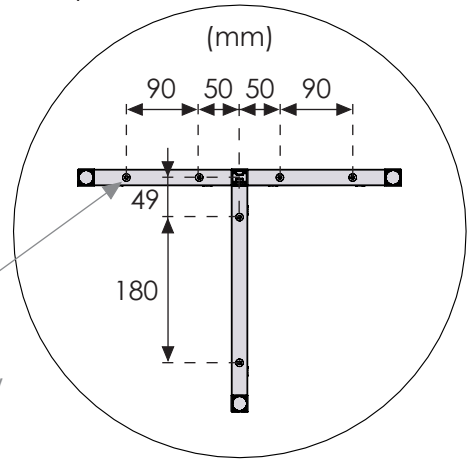

3
Cache trou /
Hole cover

2 Fixez le piètement au plan de travail /
Fix the leg to the worktop

