

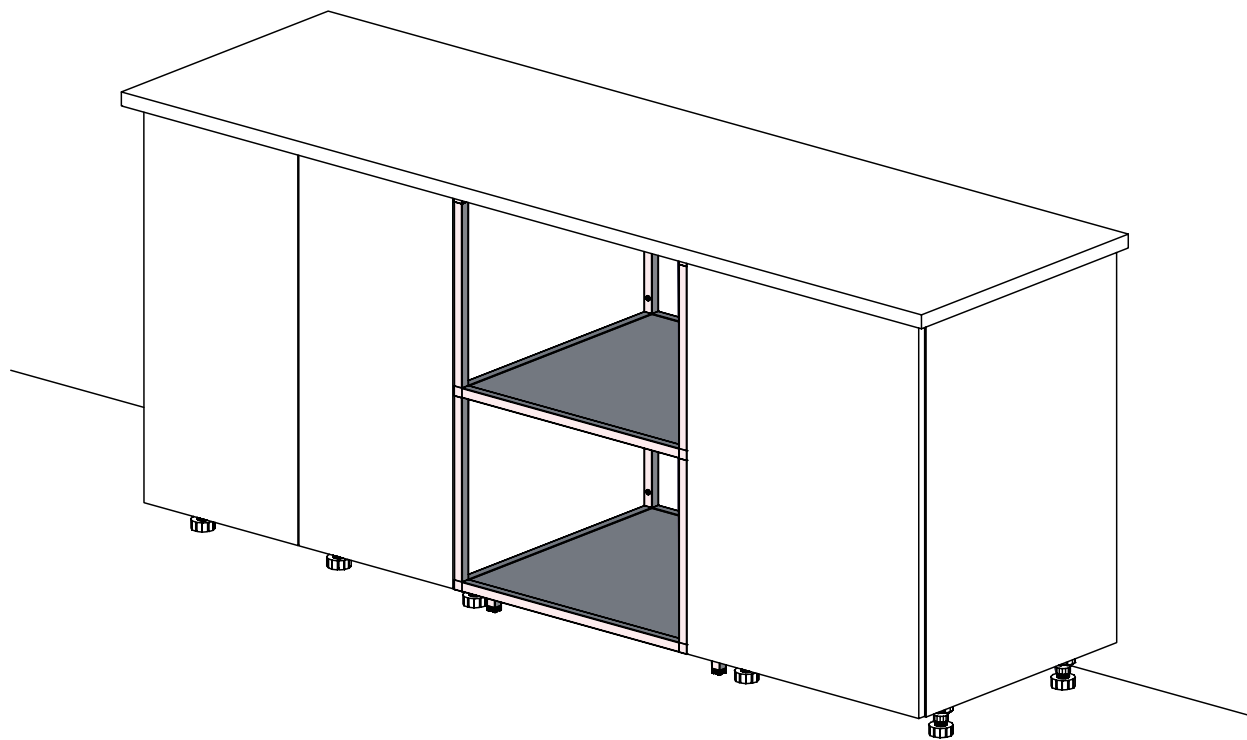

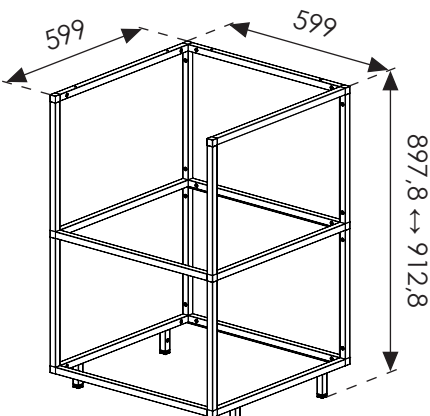

# Niche métal sur pieds

## Metal niche on legs

Instructions de montage  
Mounting instructions





Dimensions (mm)	Références / References
 <p>599</p> <p>599</p> <p>897,8 ↔ 912,8</p>	<p data-bbox="810 1579 869 1601">MPA</p> <hr/> <p data-bbox="997 1780 1300 1803">Nécessaire / Necessary</p> <div data-bbox="869 1848 1444 1982"> x 1  30 min </div>

Glossaire / Glossary

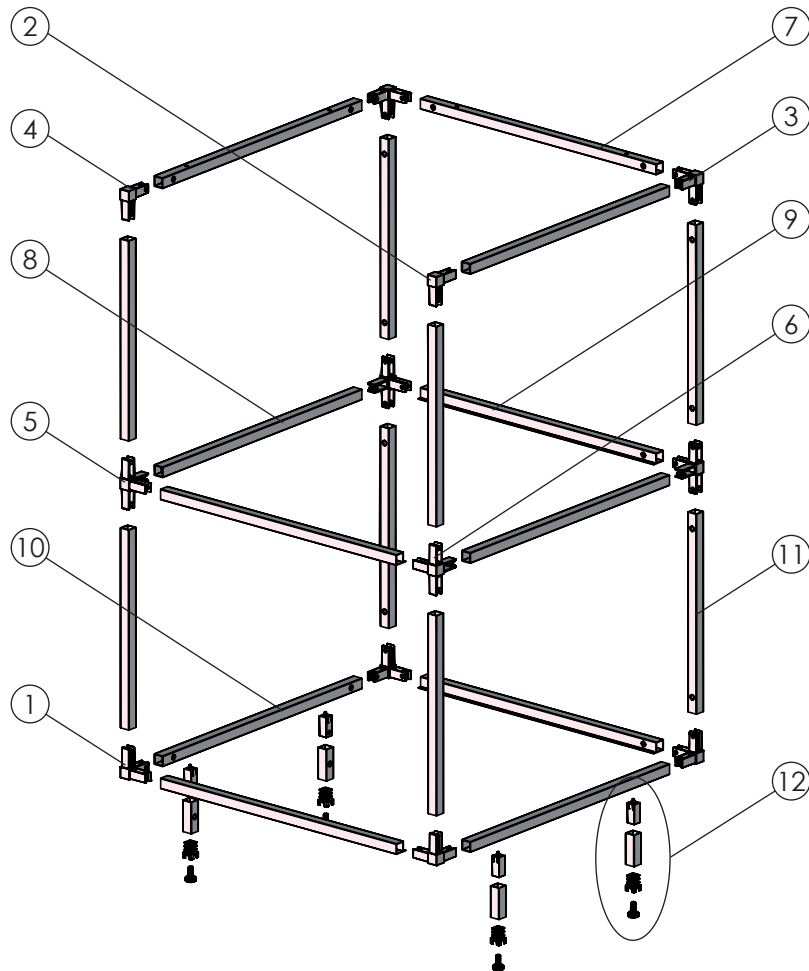

1	Angle <b>A</b> / Corner <b>A</b>	7	Tube percé sous plan de travail / Drilled tube under worktop
2	Angle <b>A*</b> / Corner <b>A*</b>	8	Tube pour profondeur / Tube for depth
3	Angle <b>B</b> / Corner <b>B</b>	9	Tube pour largeur / Tube for width
4	Angle <b>B*</b> / Corner <b>B*</b>	10	Tube percé pour pieds / Drilled tube for legs
5	Angle <b>C</b> / Corner <b>C</b>	11	Tube pour hauteur / Tube for height
6	Angle <b>D</b> / Corner <b>D</b>	12	Pied / Leg

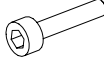

Quincaillerie / Hardware

									
A	B	C	D						

Outils non fournis / Not supplied tools

									
---	---	--	--	--	--	--	--	--	--



Angle A / Corner A

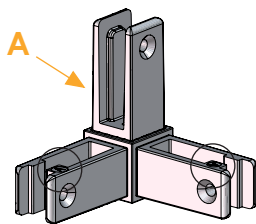

Angle A\* / Corner A\*

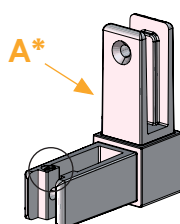

Angle C / Corner C

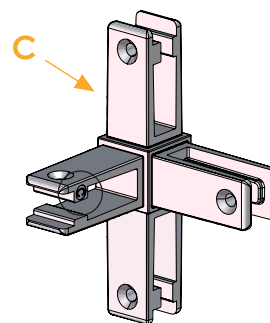

Angle B / Corner B

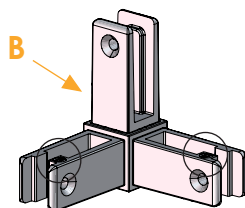

Angle B\* / Corner B\*

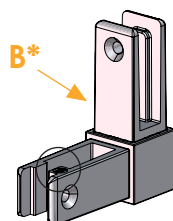

Angle D / Corner D

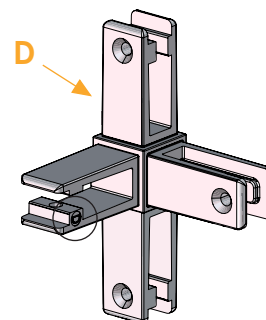

**1** Montage de la partie haute / Mounting the upper part

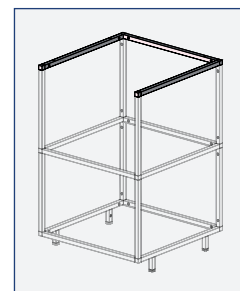
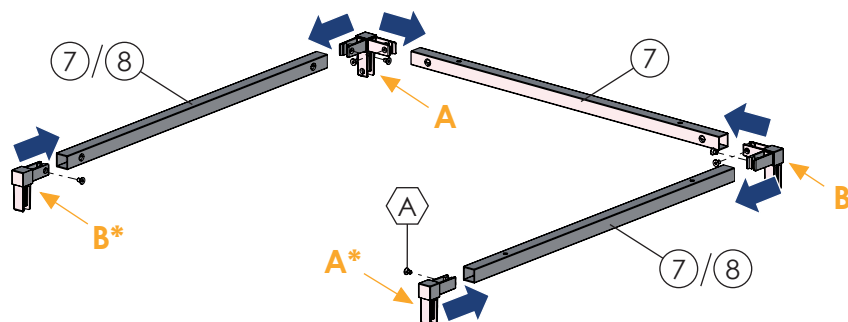

Si votre niche est en bout de linéaire, positionnez le 2<sup>ème</sup> tube percé (7) vers l'extérieur / If your niche is at the end of a linear, place the 2<sup>nd</sup> drilled tube (7) outwards

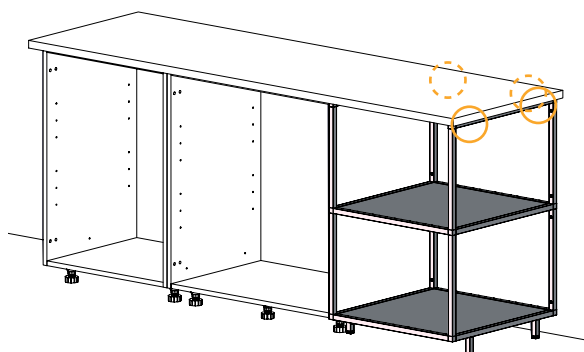

## 2 Montage de la partie centrale / Mounting the central part

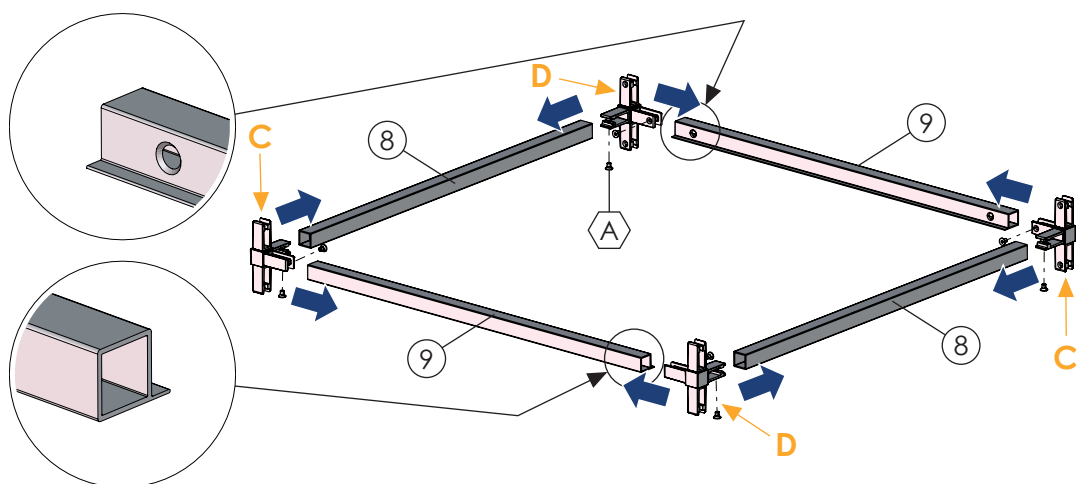

## 3

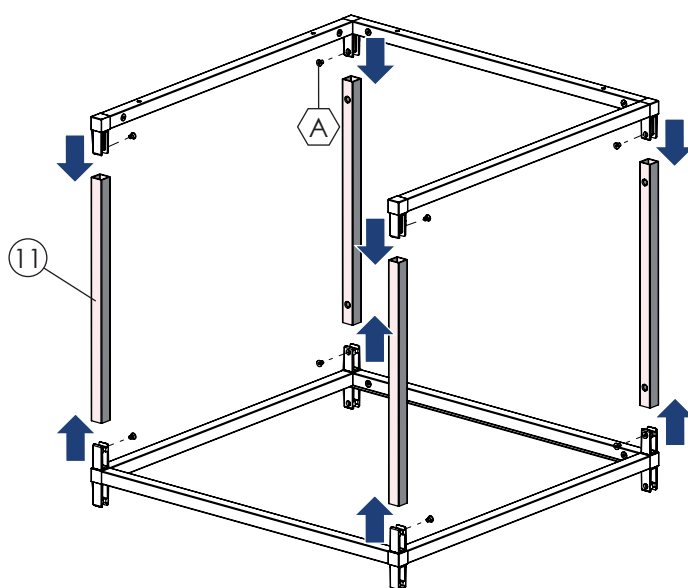

## 4 Montage de la partie basse / Mounting the lower part

### 1

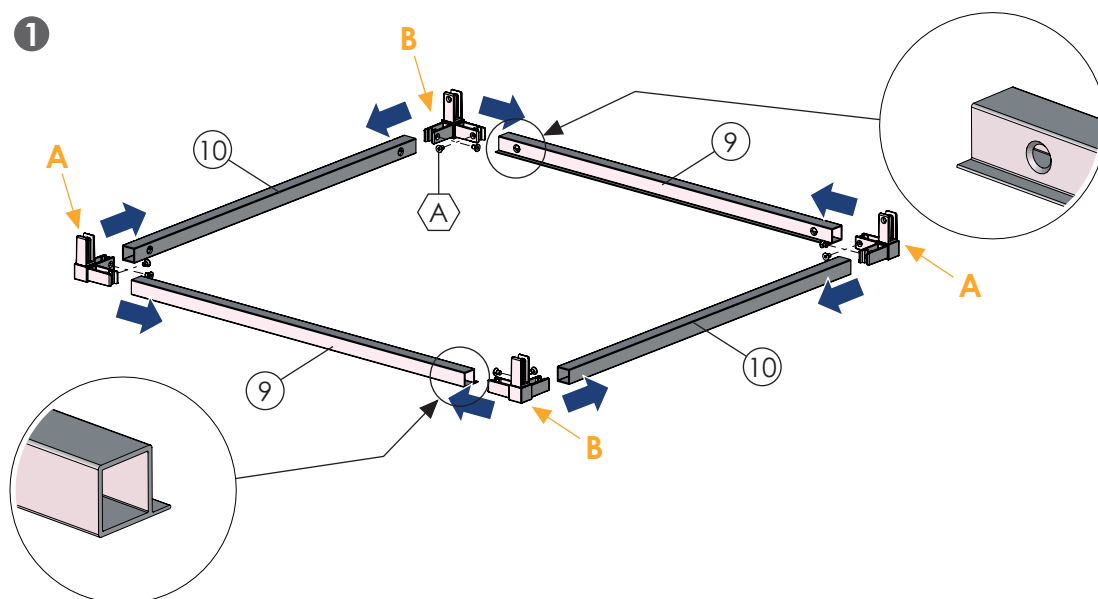

## 2 Montage des pieds / Mounting the legs

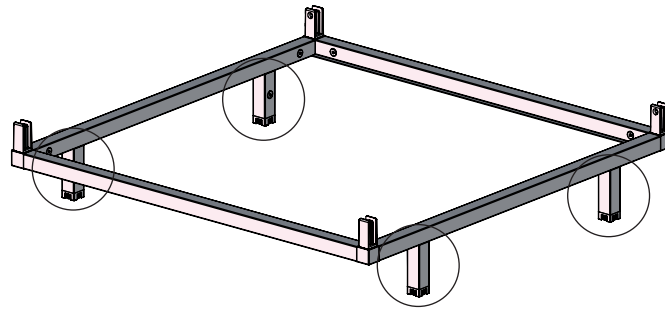

1

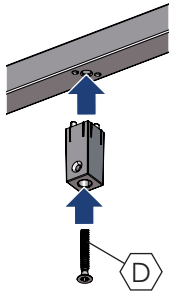

2



3

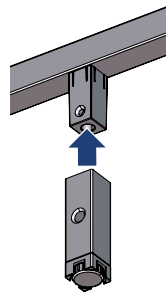

4

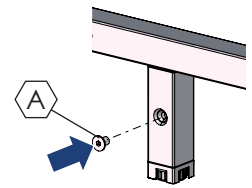

5

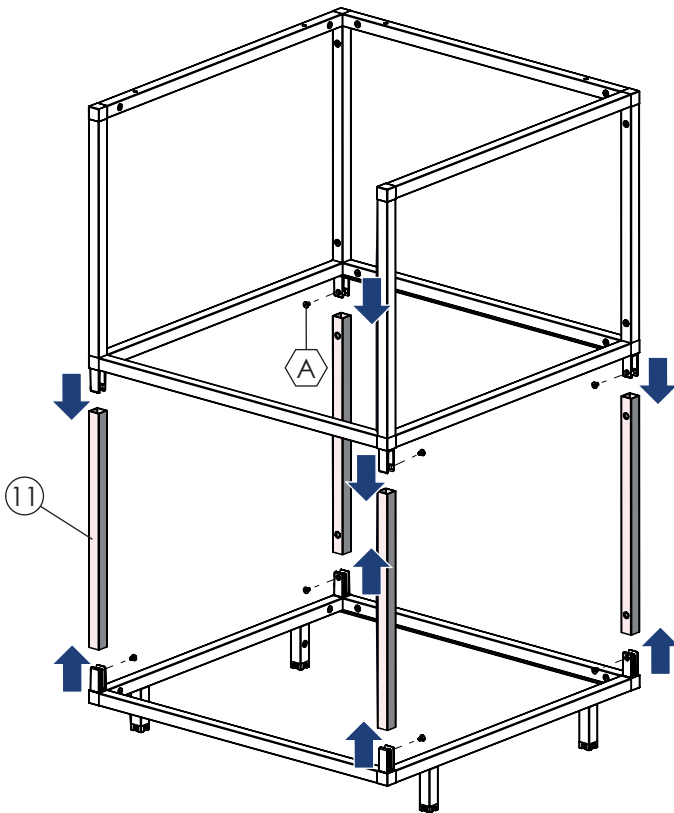

6

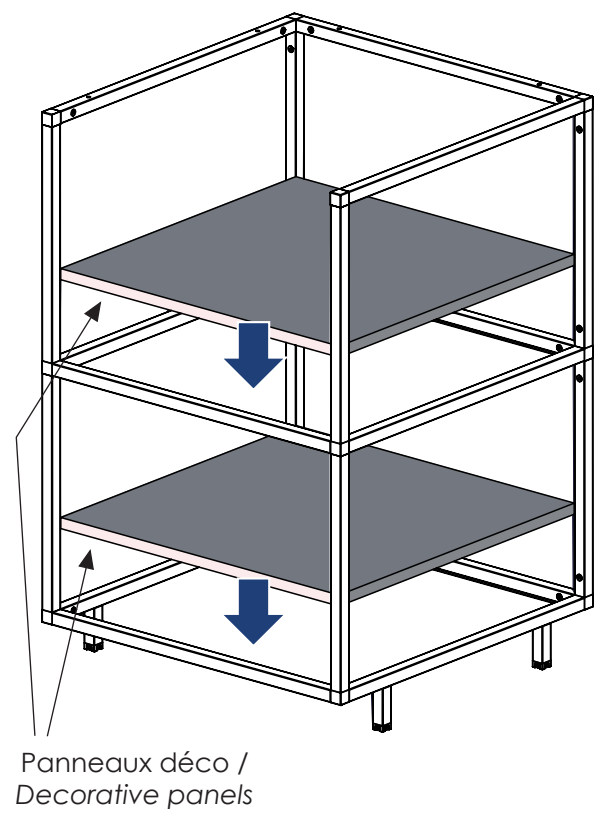

7

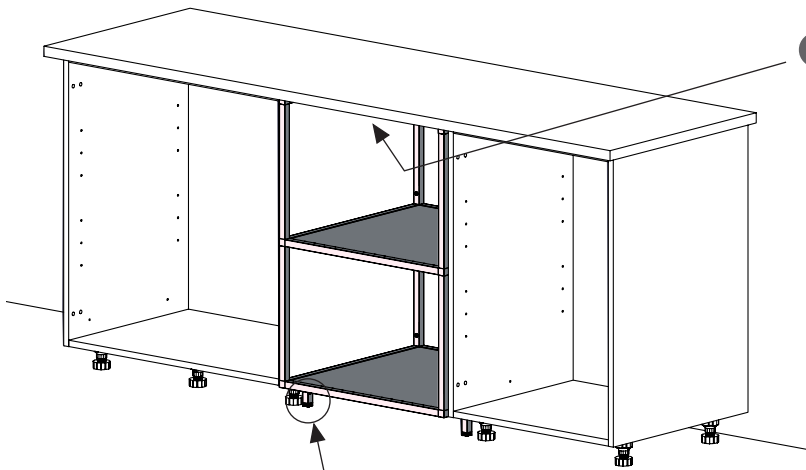

1 Si besoin, pré-percez le plan de travail /  
If needed, drill pilot holes under the  
worktop

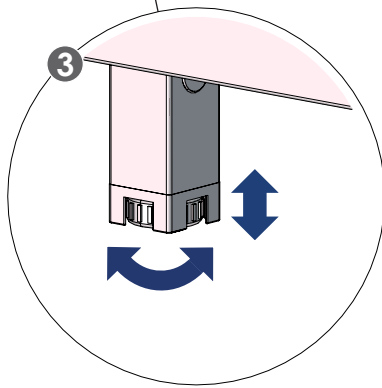
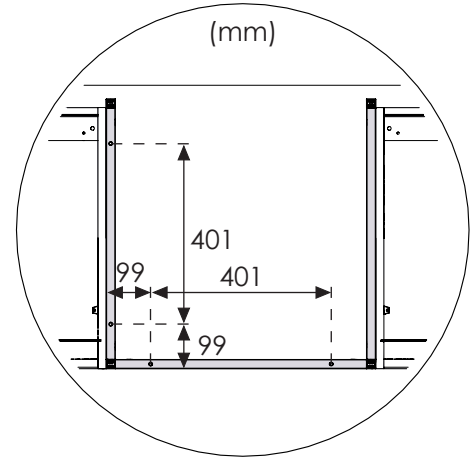

2 Fixez la niche au plan de travail /  
Fix the niche to the worktop

**i** Si votre niche est en bout de linéaire, le tube percé sous le plan de travail doit être côté extérieur /  
If your niche is at the end of a linear, the drilled tube under the worktop must be outward

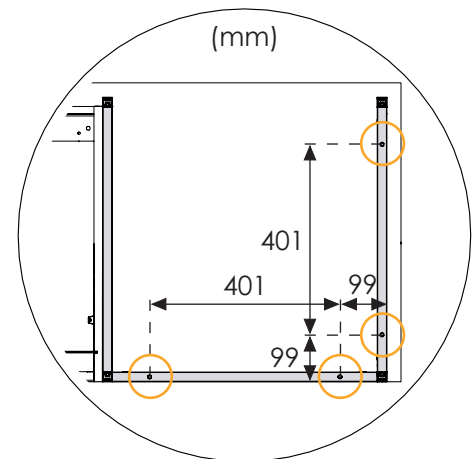
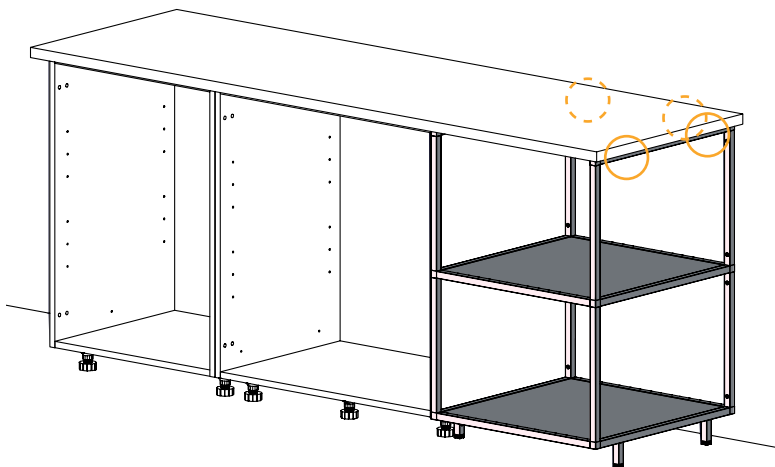

**i** Montage des socles / Plinths assembly

Le retour de socle doit s'installer sous la niche, devant ou derrière pieds arrières de la niche. / The plinth return has to be installed under the niche, in front or behind the back legs of the niche.

