

# PORTES DOORS

## INSTRUCTIONS DE MONTAGE ASSEMBLY INSTRUCTIONS

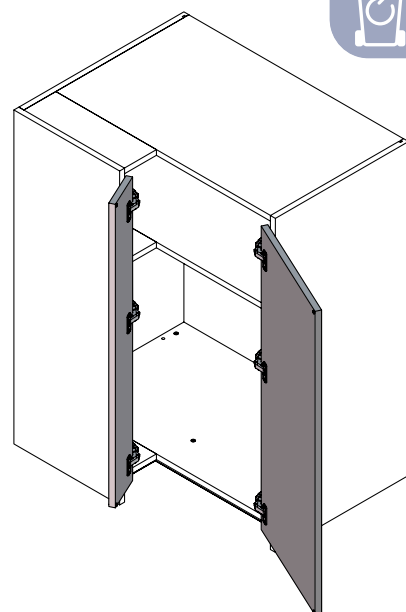

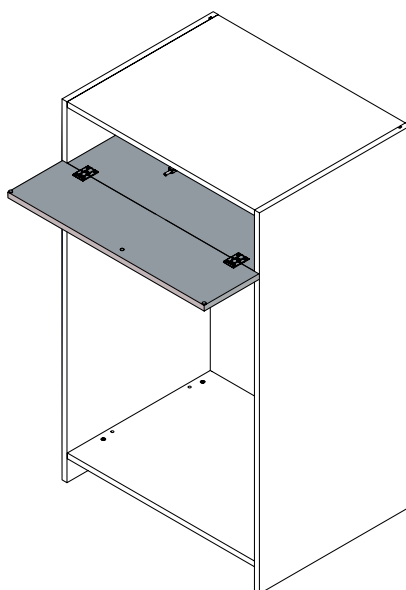

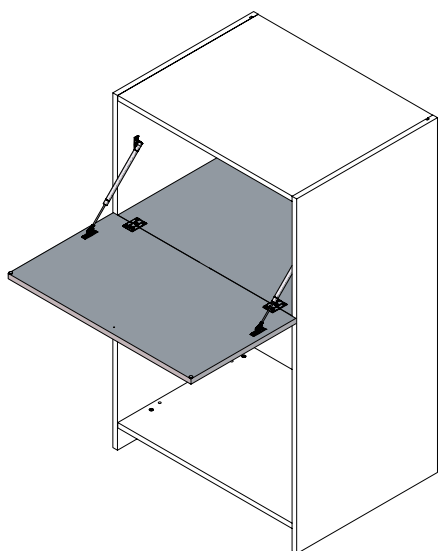
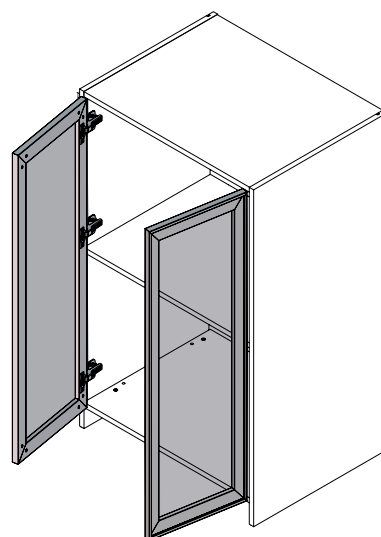
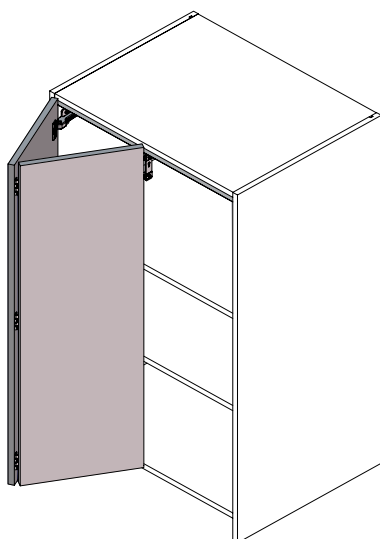
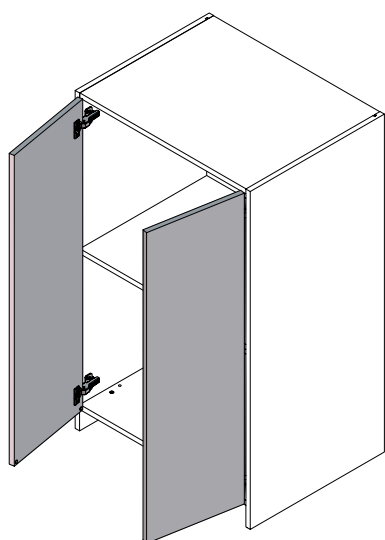





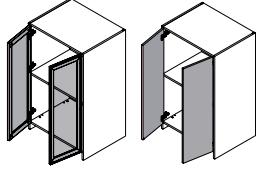

FR  
Donnez ou recyclez vos meubles.  
Association ou  
Magasin ou  
Déchèterie  
<https://quefairedesdechets.fr>

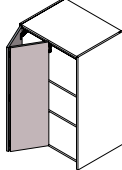

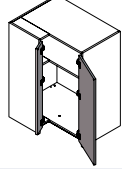
FR  
ÉLÉMENTS D'EMBALLAGE À SÉPARER ET À DÉPOSER DANS LE BAC DE TRI

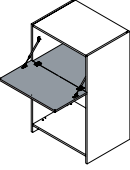

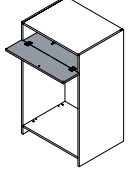

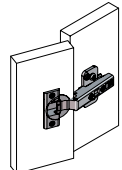
**ATTENTION:** les colonnes doivent être fixées à un mur ou à des meubles adjacents. /  
**CAUTION:** columns must be fastened to a wall or to nearby pieces of furniture.

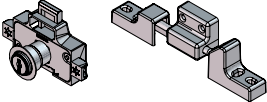
<b>1</b>	PORTES OUVRANTES / SWINGING DOORS			3
<b>2</b>	PORTES PLIANTES / BIFOLD DOORS			7
<b>3</b>	PORTES OUVRANTES RETOUR D'ANGLE / SWINGING DOORS FOR CORNERS			12
<b>4</b>	PORTE ABATTANTE AVEC VÉRIN / FLAP DOOR WITH CYLINDER			16
<b>5</b>	PORTE ABATTANTE SANS VÉRIN / FLAP DOOR WITHOUT CYLINDER			22
<b>6</b>	RÉGLAGE DES CHARNIÈRES / HINGES ADJUSTMENTS			23



Pour le montage de serrures et cocottes sur les portes /  
For locks and shutting mechanisms assembly on doors

Accessoires / Accessories  
NOT\_0000575

OUTILLAGE NON FOURNI / NOT SUPPLIED

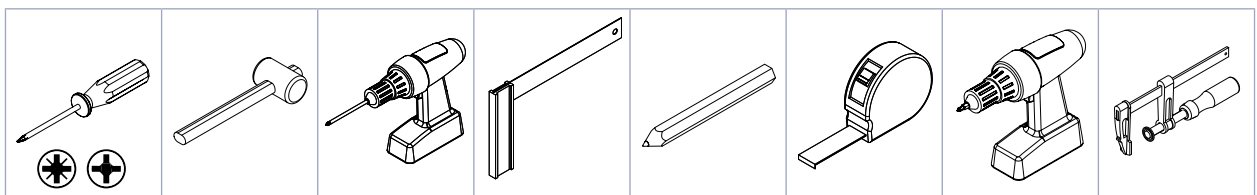

TYPES DE PORTES / DOOR POSSIBILITIES

"SA" = Porte **semi-applique** / Partial overlay door

"AT" = Porte **applique totale** / Overlay door

"RT" = Porte **rentrante** / Inset door

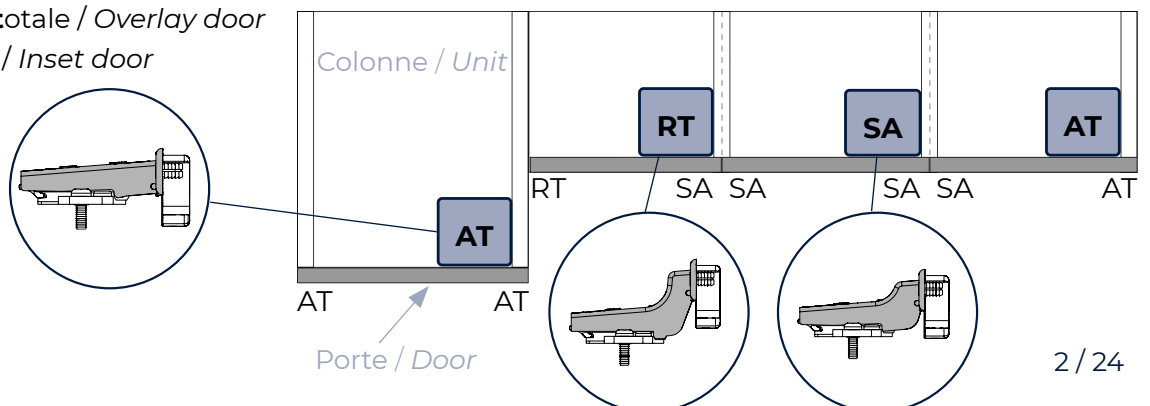

# 1 PORTES OUVRANTES / SWINGING DOORS

## GLOSSAIRE / GLOSSARY

1 Portes ouvrantes panneau / Panel swinging doors

2 Portes ouvrantes vitrine / Window swinging doors

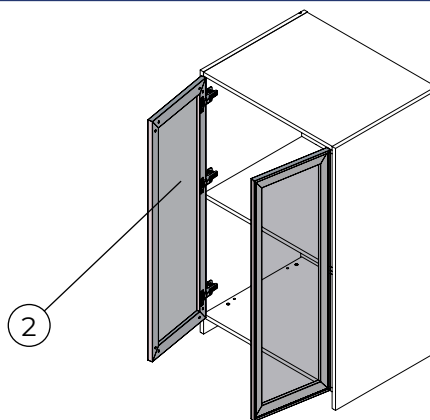
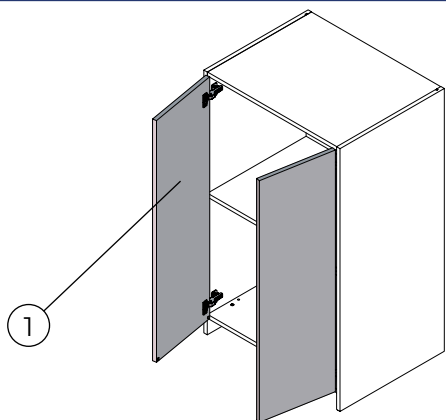

## QUINCAILLERIE / HARDWARE

ENS008 - ENS009 : 110°  
(Porte applique totale/Overlay door)

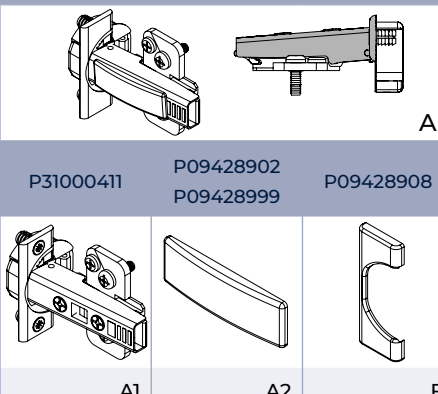

A1 P09428902 P09428908  
P31000411 P09428999

ENS011 : 110°  
(Porte semi applique/Partial overlay door)

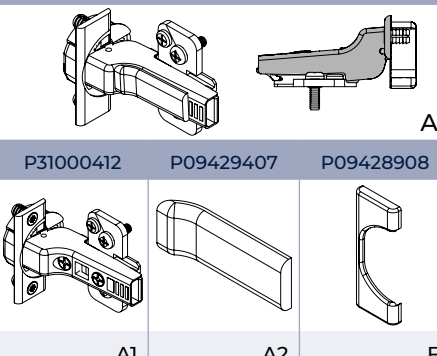

A1 P09429407 P09428908  
P31000412

ENS010 : 110°  
(Porte rentrante/Inset door)

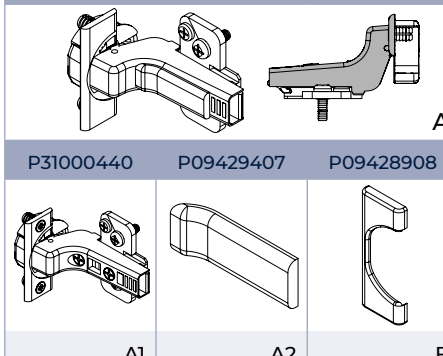

A1 P09429407 P09428908  
P31000440

ENS013 : 155°  
(Porte semi applique/Partial overlay door)

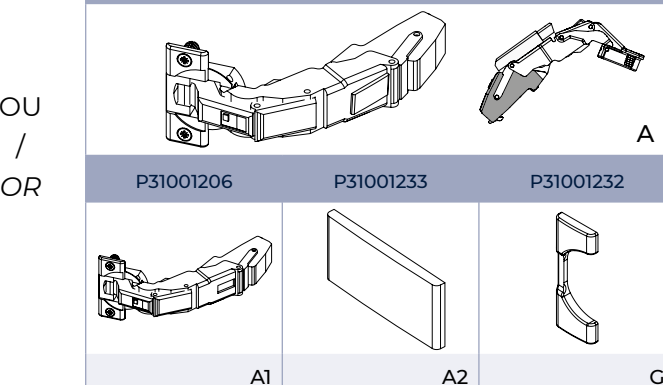

A1 P09428908 P09428908  
P31001206 P31001233 P31001232

ENS012 : 155°  
(Porte applique totale/Overlay door)

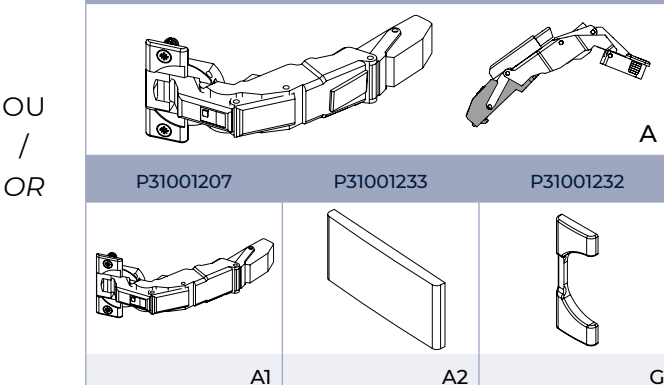

A1 P09428908 P09428908  
P31001207 P31001233 P31001232

P09451704 P09452400 P31090700 P41000143 P09428908 P31001232 P09428500

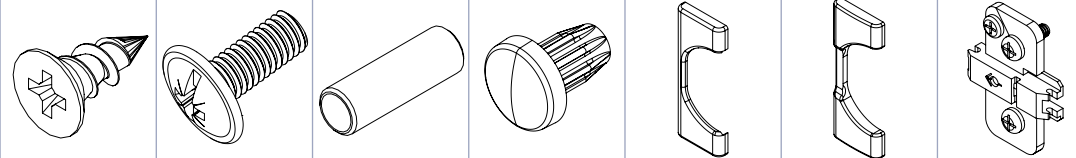

Ø3,5x9,5 B Ø4x10 C M4Ø5x15 D E 110° F 155° G H

Optionnel / Optional  
P09448950

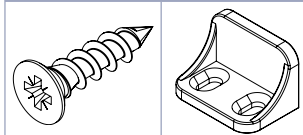

Ø3,5x15 I1 I2

# 1 Portes battantes sur panneau / Panel opening doors

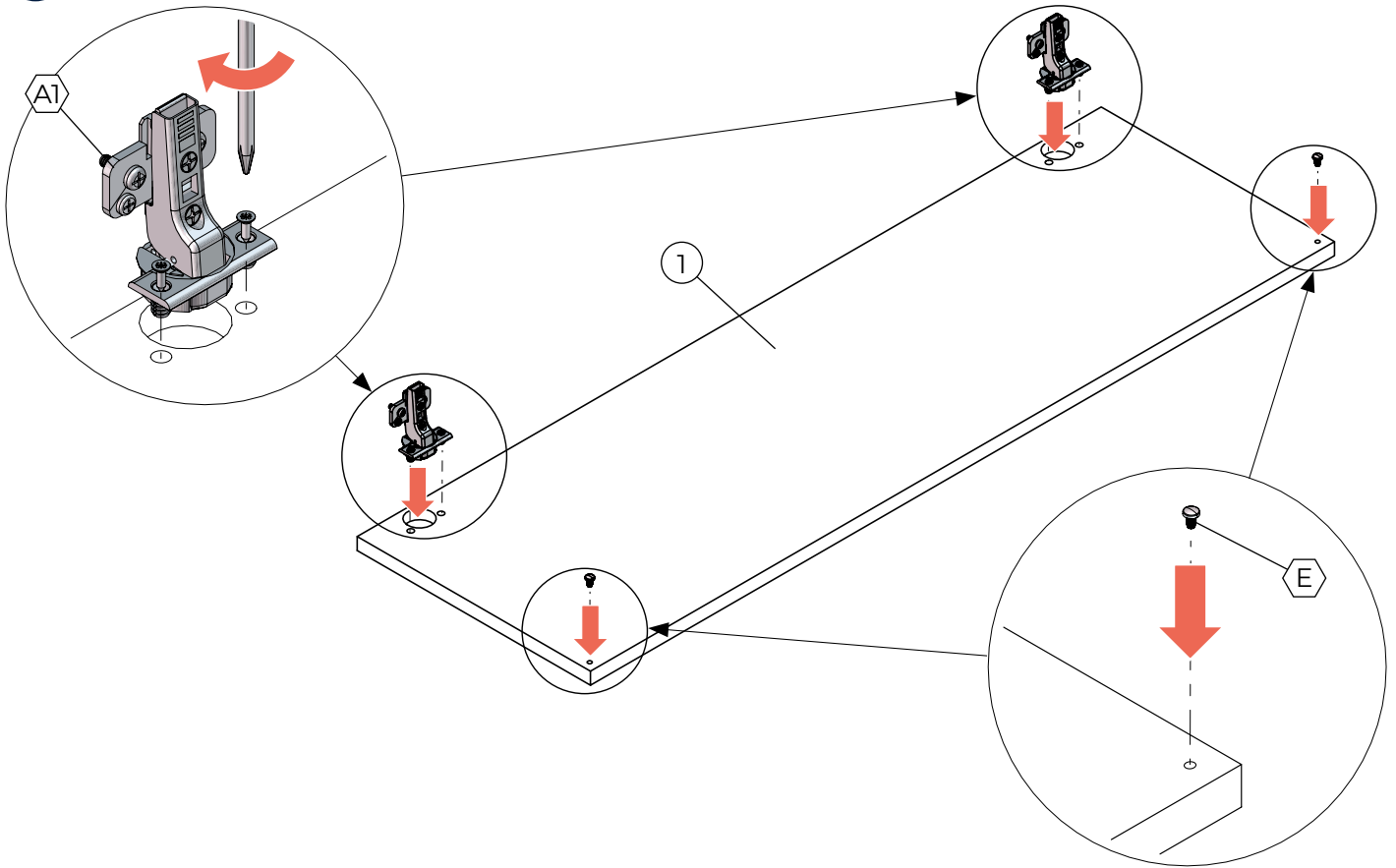

# 2 Portes battantes sur cadre aluminium / Aluminium opening doors

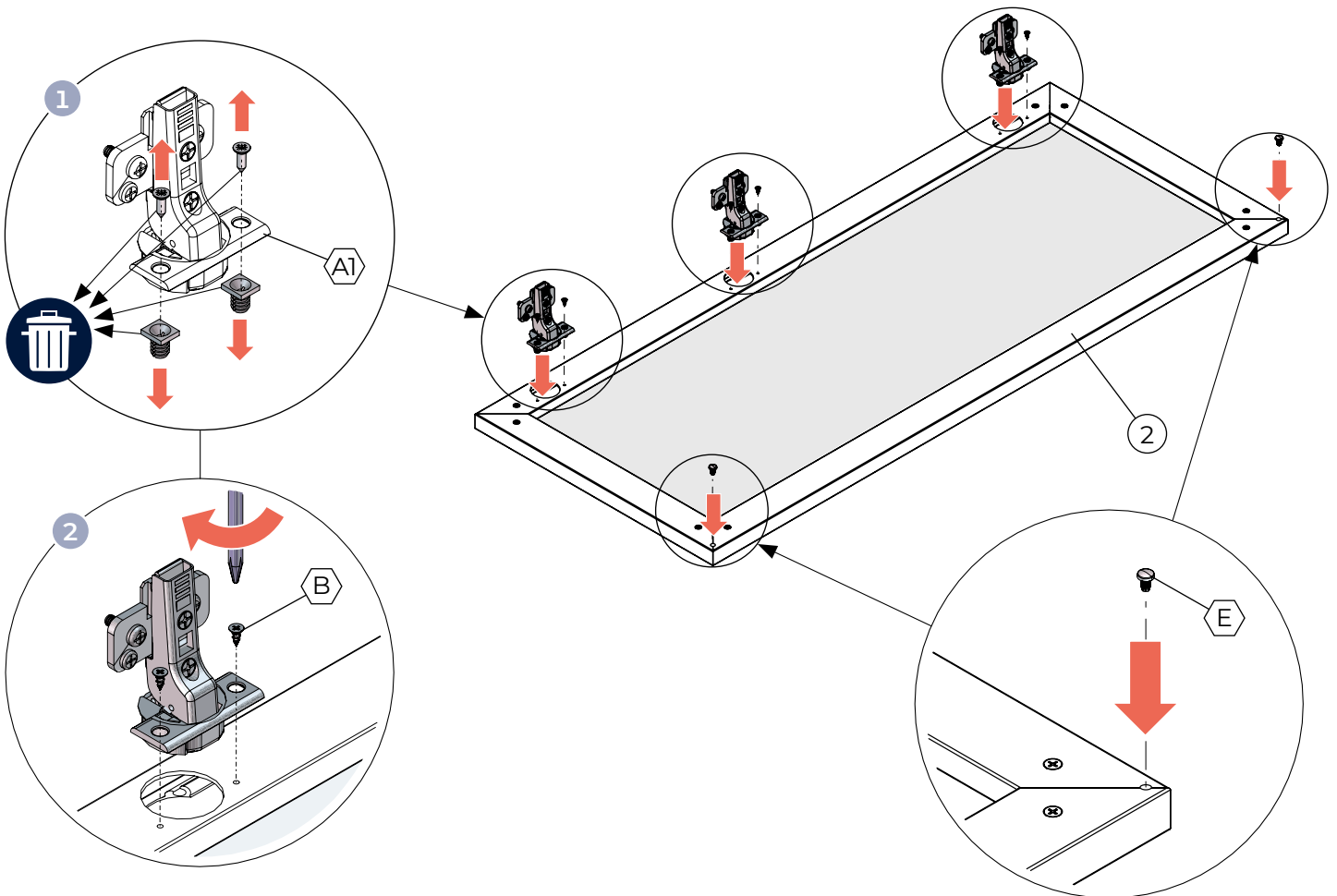

3

1

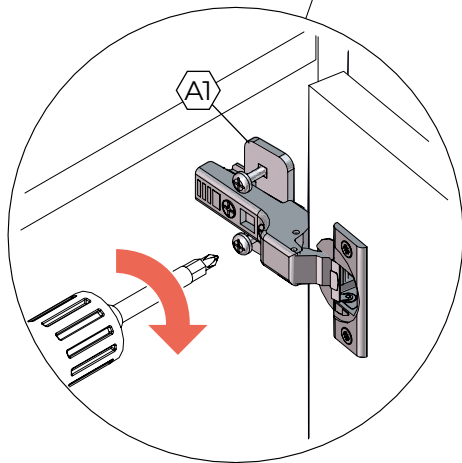
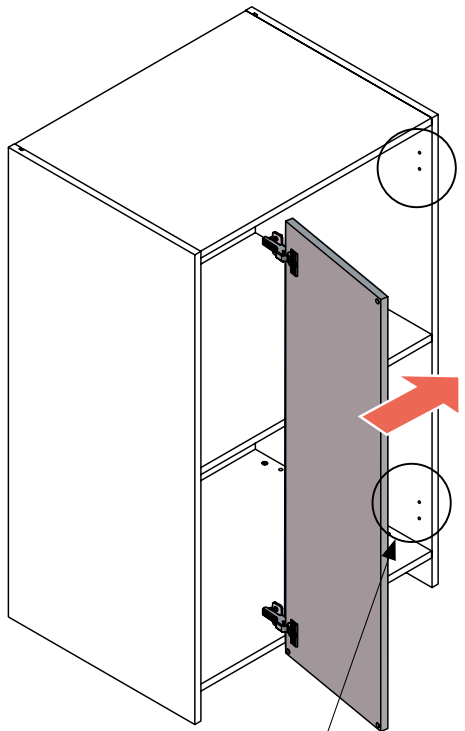

2

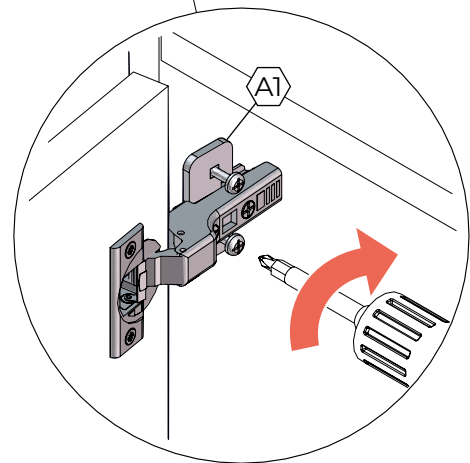
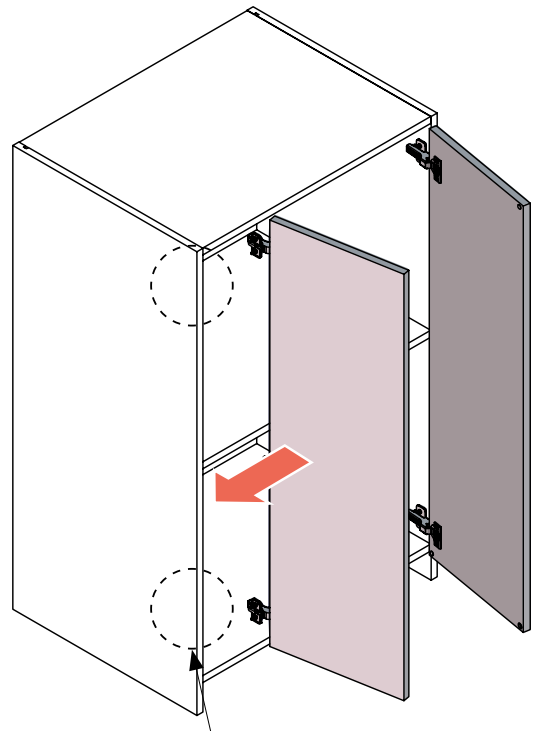

Dans le cas d'un montage de 2 charnières en face à face, il faut enlever les inserts plastique des platines A, puis utiliser l'ensemble « tube d'assemblage D + 2 vis poêlier C » / When assembling 2 hinges face to face, remove the A plate plastic inserts, then use the "assembly tube D + 2 truss screws C" kit

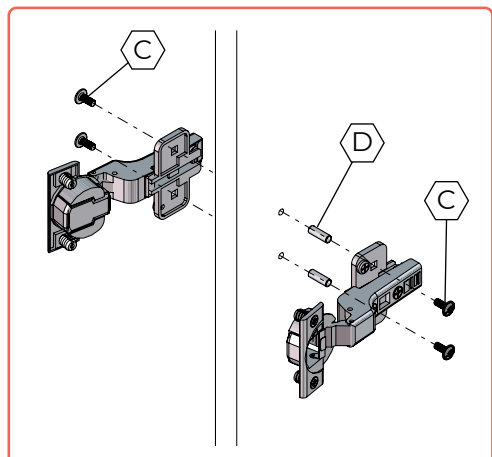
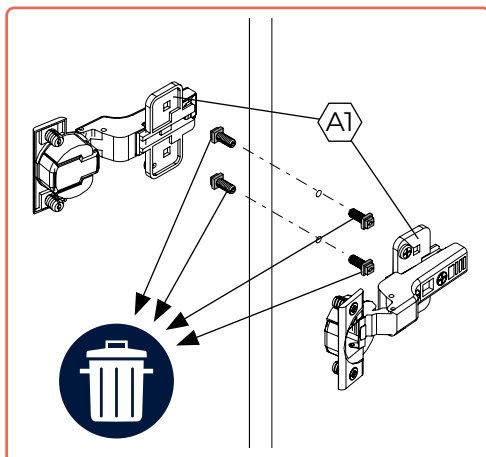

4

Si besoin : butée pour porte rentrante / If necessary: inset door stopper



Plusieurs positions possibles : /  
Different position possibilities:

Portes double sous abattant /  
Double regular doors under  
flap door

2 butées pour portes double  
rentrantes / 2 stoppers for  
double inset doors

2 butées pour porte simple  
rentrante / 2 stoppers for  
simple inset door

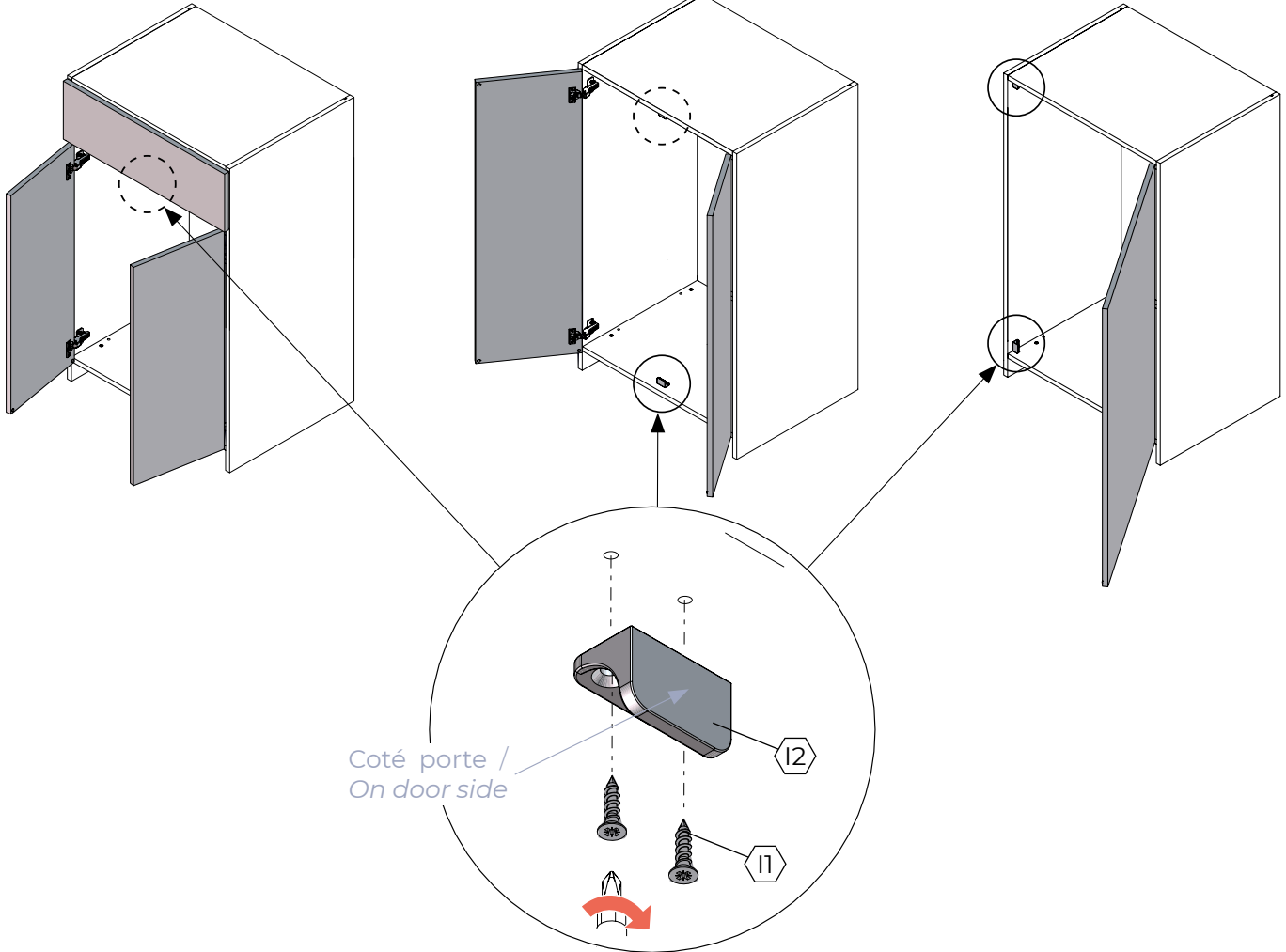

5

Réglages / Adjustments

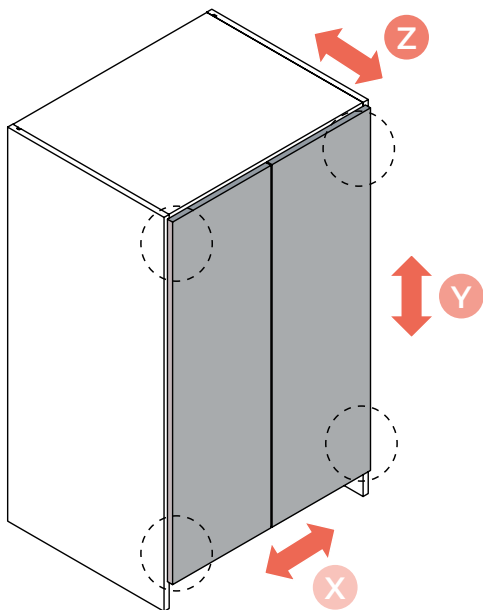

Spécifiques selon charnières /  
Depends on hinges choice



p.23

6 RÉGLAGE DES CHARNIÈRES /  
HINGES ADJUSTMENTS

# 2 PORTES PLIANTES / BIFOLD DOORS

## GLOSSAIRE / GLOSSARY

1      Porte fixe / <i>Static door</i>	2      Porte coulissante / <i>Folding door</i>
--	--

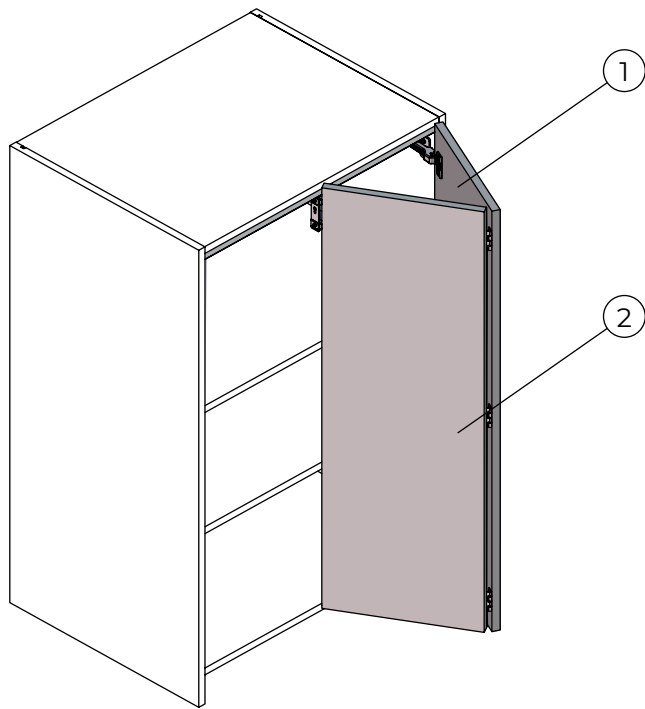

## QUINCAILLERIE / HARDWARE

**ENS008 - ENS009 : 110°**  
(Porte applique totale/Overlay door)

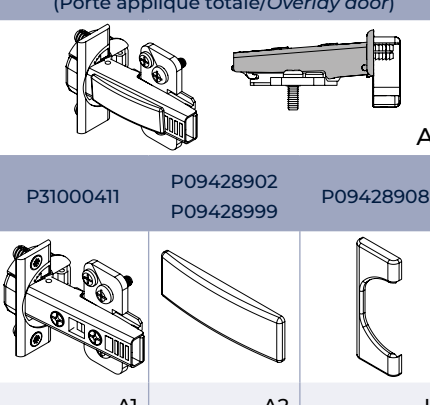

A

P31000411      P09428902      P09428908  
P09428999

A1      A2      H

OU  
/  
OR

**ENS011 : 110°**  
(Porte semi applique/Partial overlay door)

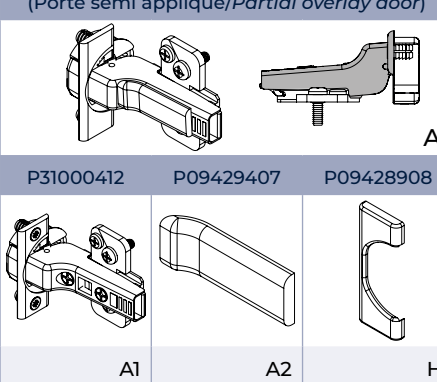

A

P31000412      P09429407      P09428908

A1      A2      H

**P31001240**

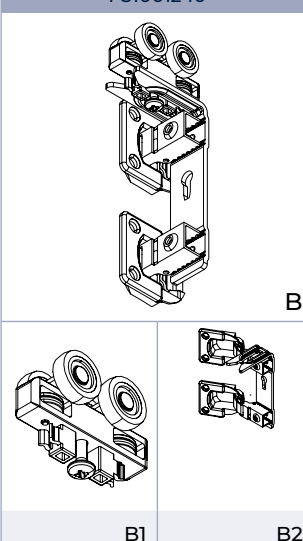

B

B1      B2

<b>P31082504</b>	<b>P29454000</b>	<b>PRF001</b>	<b>P41000143</b>	<b>P09457301</b>	<b>P09428908</b>
C	Ø3,5x15	D	E	F      Ø6x12,7	G      H

1

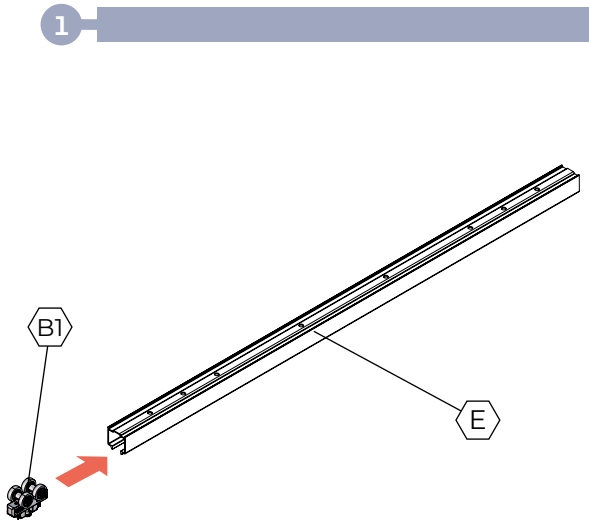

2

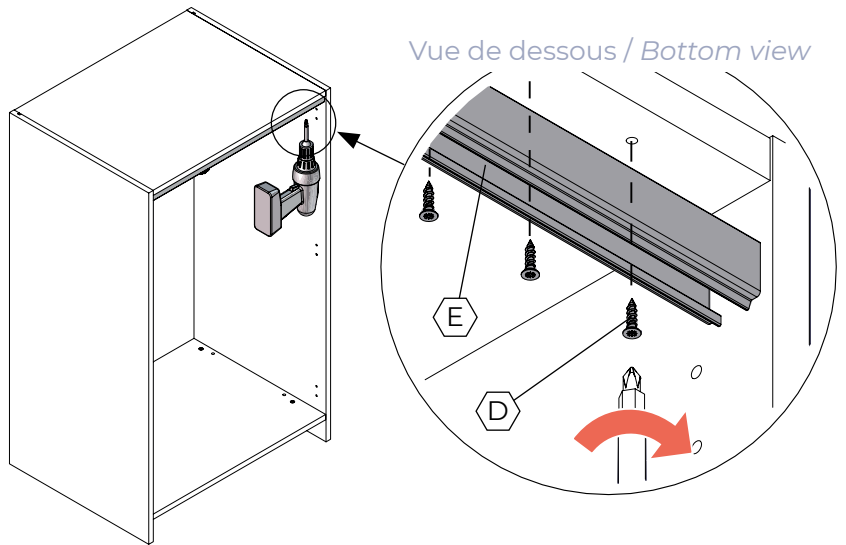

2

## Poignée porte pliante / Bifold door handle

1

### Perçage / Drilling

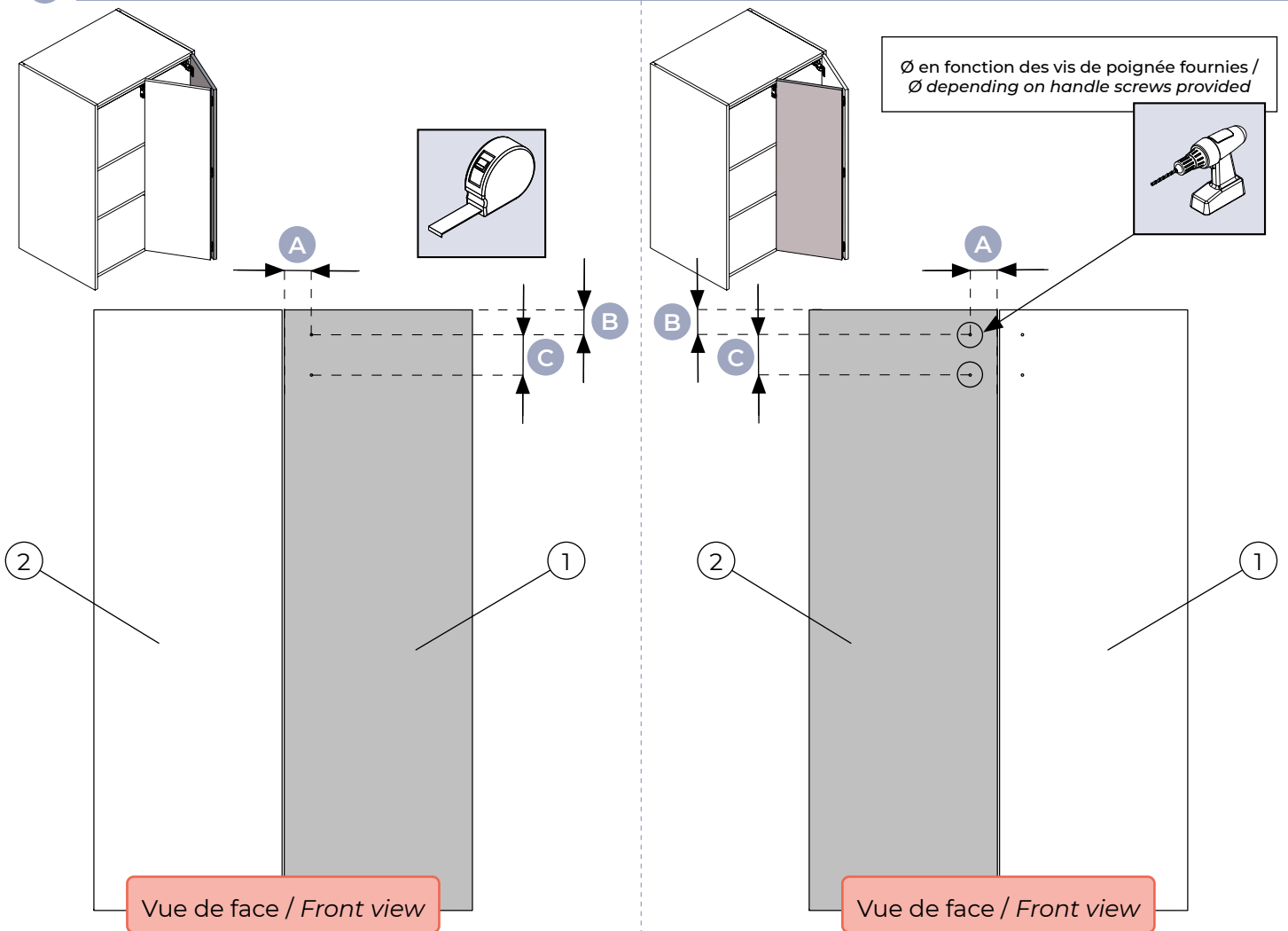

2

### Monter les poignées / Assemble the handles



Le montage se fait de façon symétrique pour un meuble avec ouverture de porte vers la gauche / *Installation is symmetrical for a unit with door opening to the left*

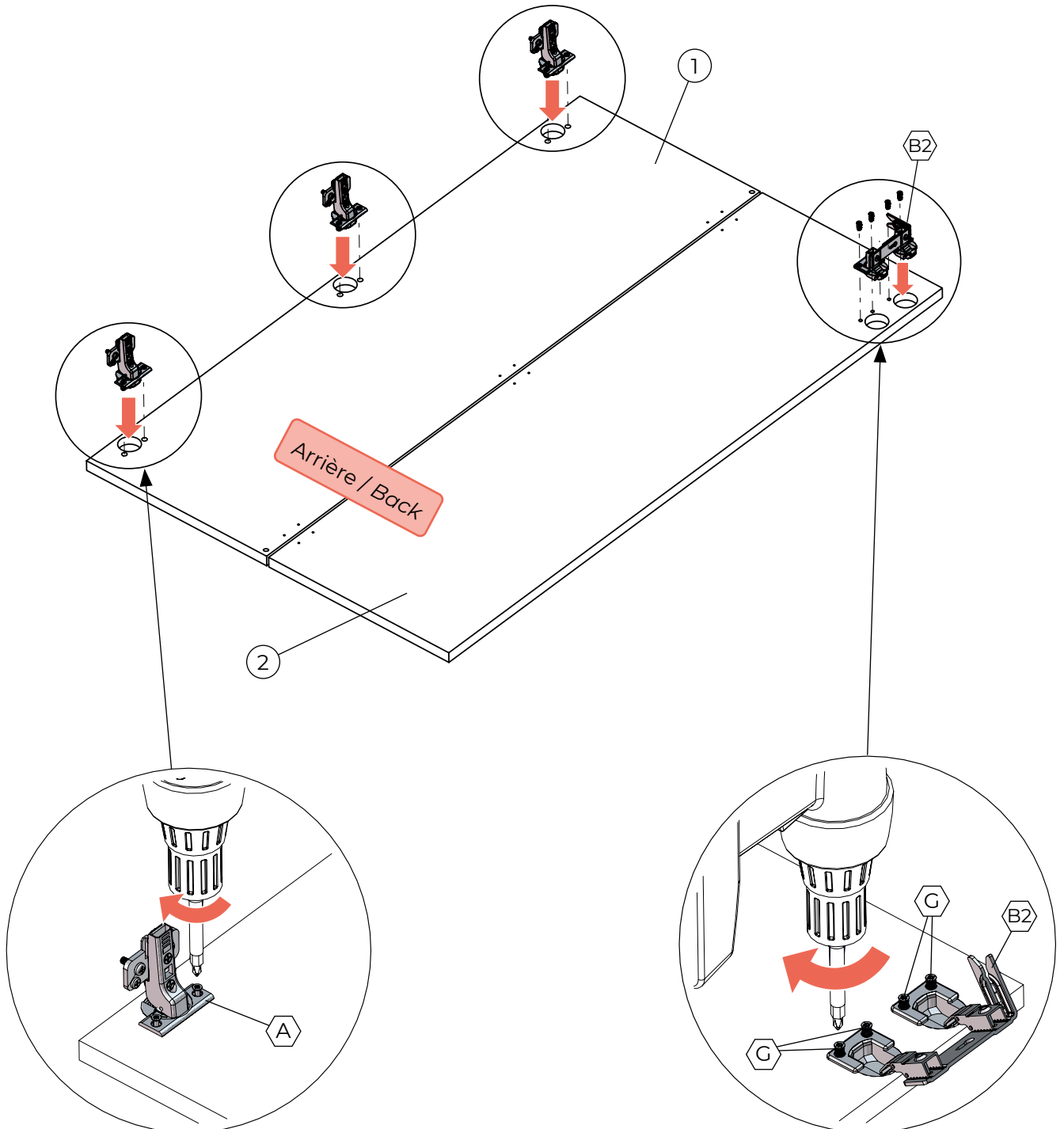

2

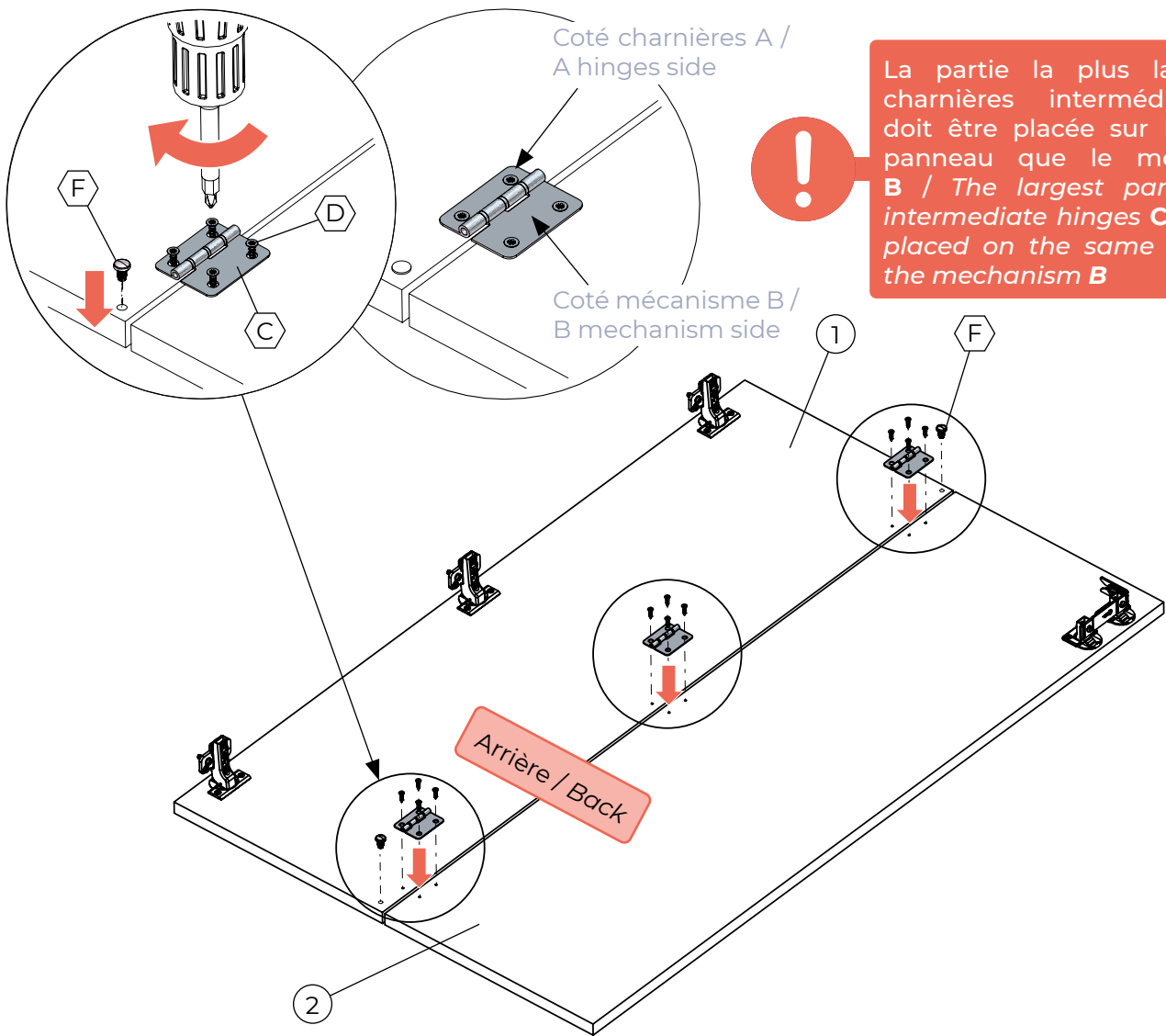

4

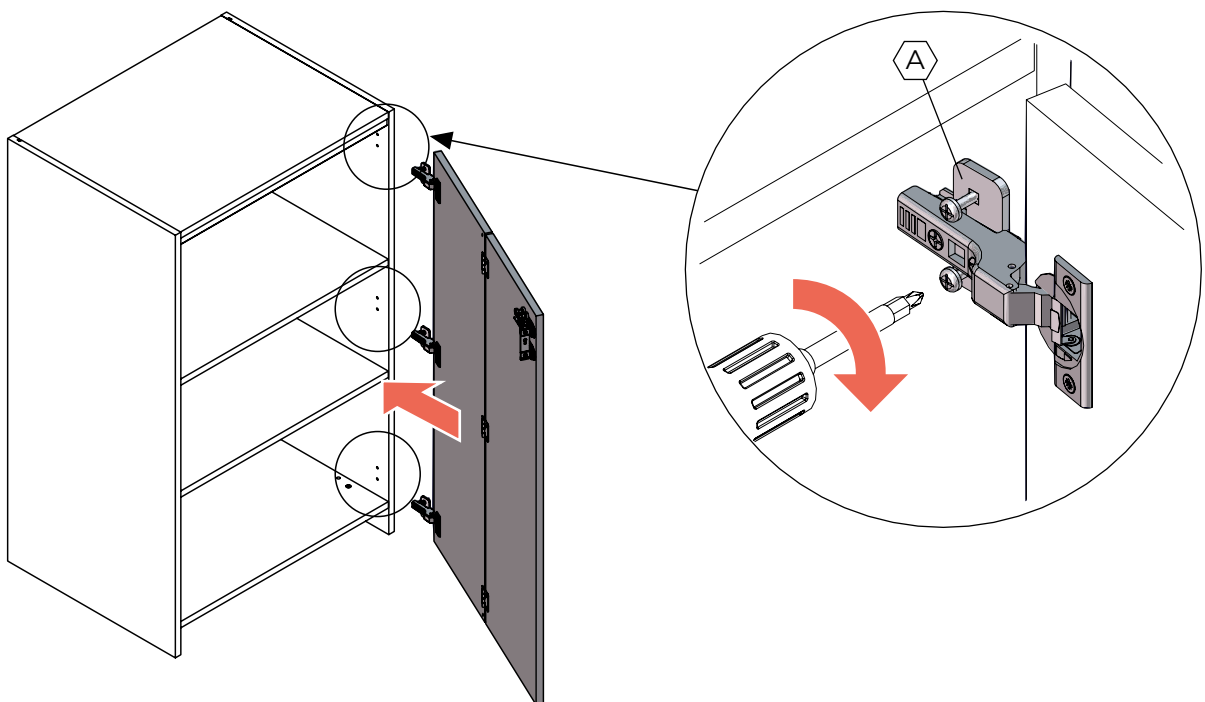

5

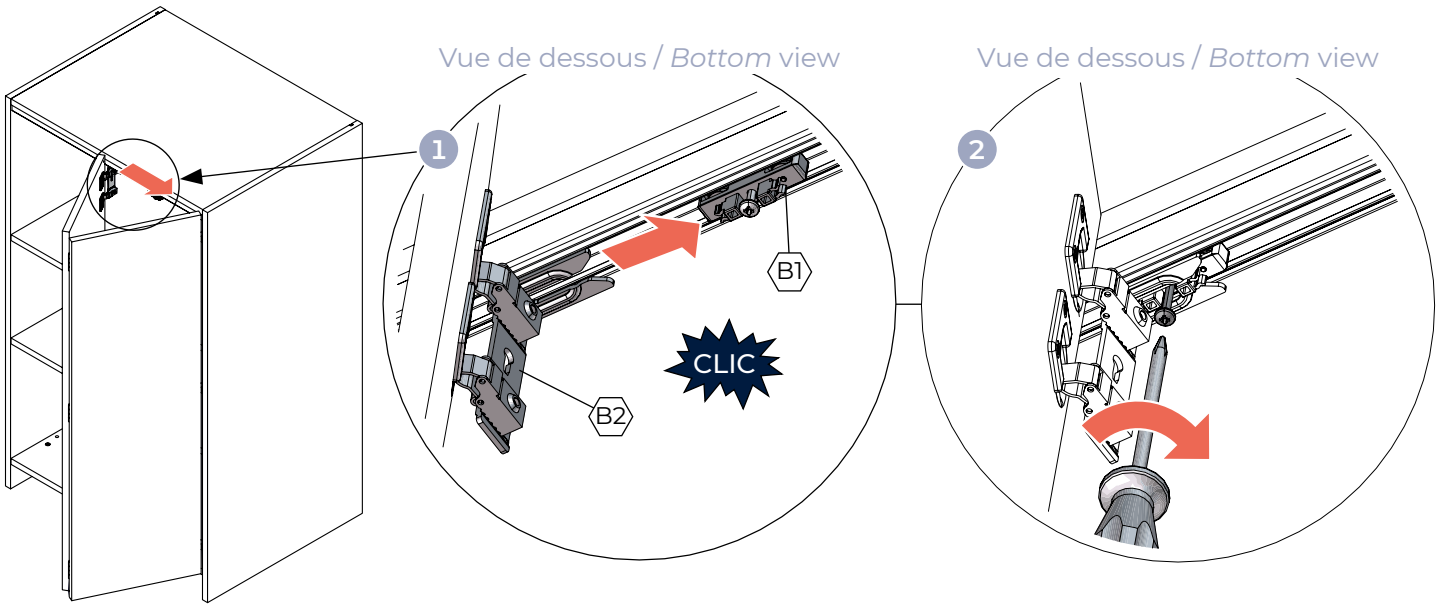

6

### Réglages / Adjustments

1

Spécifiques selon charnières /  
Depends on hinges choice

## ➔ 6 RÉGLAGE DES CHARNIÈRES / HINGES ADJUSTMENTS p.23

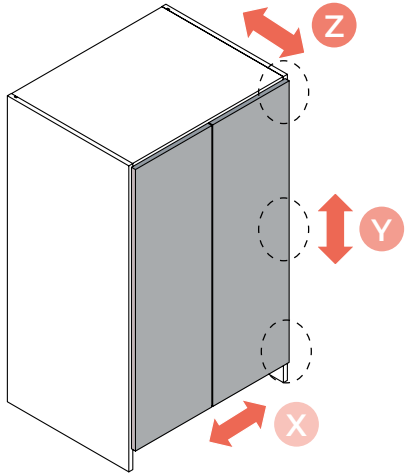

2

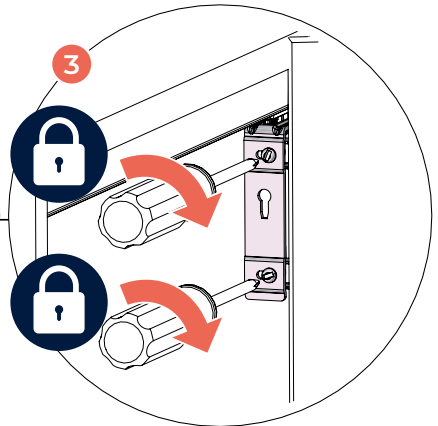
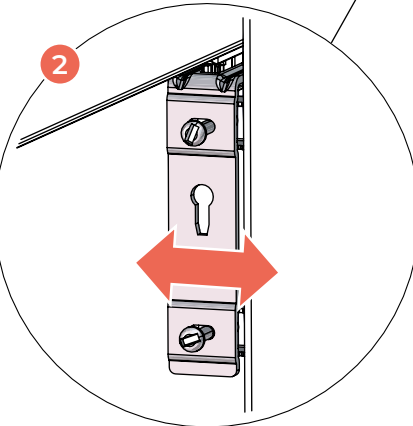
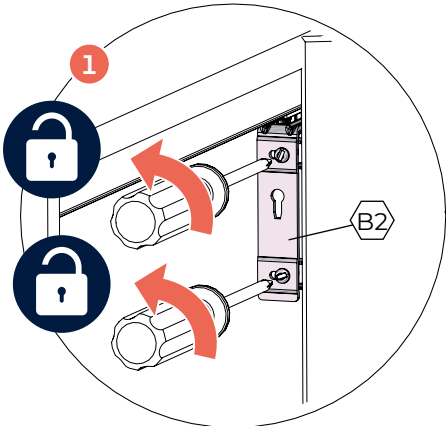
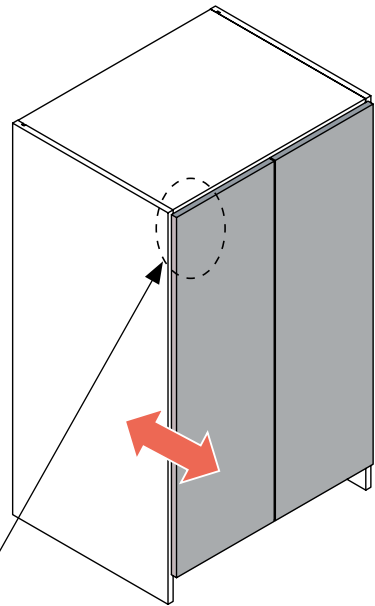

# 3 PORTES OUVRANTES RETOUR D'ANGLE / SWINGING DOORS FOR CORNERS

## GLOSSAIRE / GLOSSARY

1 Porte d'angle / Corner door

2 Porte principale / Main door

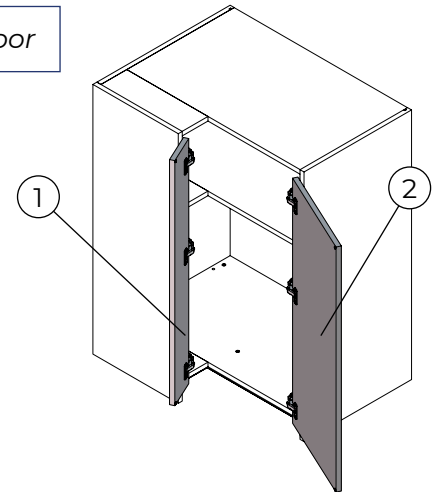

1

### QUINCAILLERIE PORTE D'ANGLE / CORNER DOOR HARDWARE

**ENS013 : 155°**  
(Porte semi applique/Partial overlay door)

A

P31001206    P31001233    P31001232

A1    A2    A3

**ENS012 : 155°**  
(Porte applique totale/Overlay door)

A

P31001207    P31001233    P31001232

A1    A2    A3

**P41000143**    **P09428500**

B    C

2

### QUINCAILLERIE PORTE PRINCIPALE / MAIN DOOR HARDWARE

**ENS008 - ENS009 : 110°**  
(Porte applique totale/Overlay door)

E

P31000411    P09428902 / P09428999    P09428908

E1    E2    F

**ENS011 : 110°**  
(Porte semi applique/Partial overlay door)

E

P31000412    P09429407    P09428908

E1    E2    F

**ENS010 : 110°**  
(Porte rentrante/Inset door)

E

P31000440    P09429407    P09428908

E1    E2    F

**P41000143**    **P09428500**    **P09428908**

B    C    F

**1** Montage porte d'angle / *Corner door assembly*

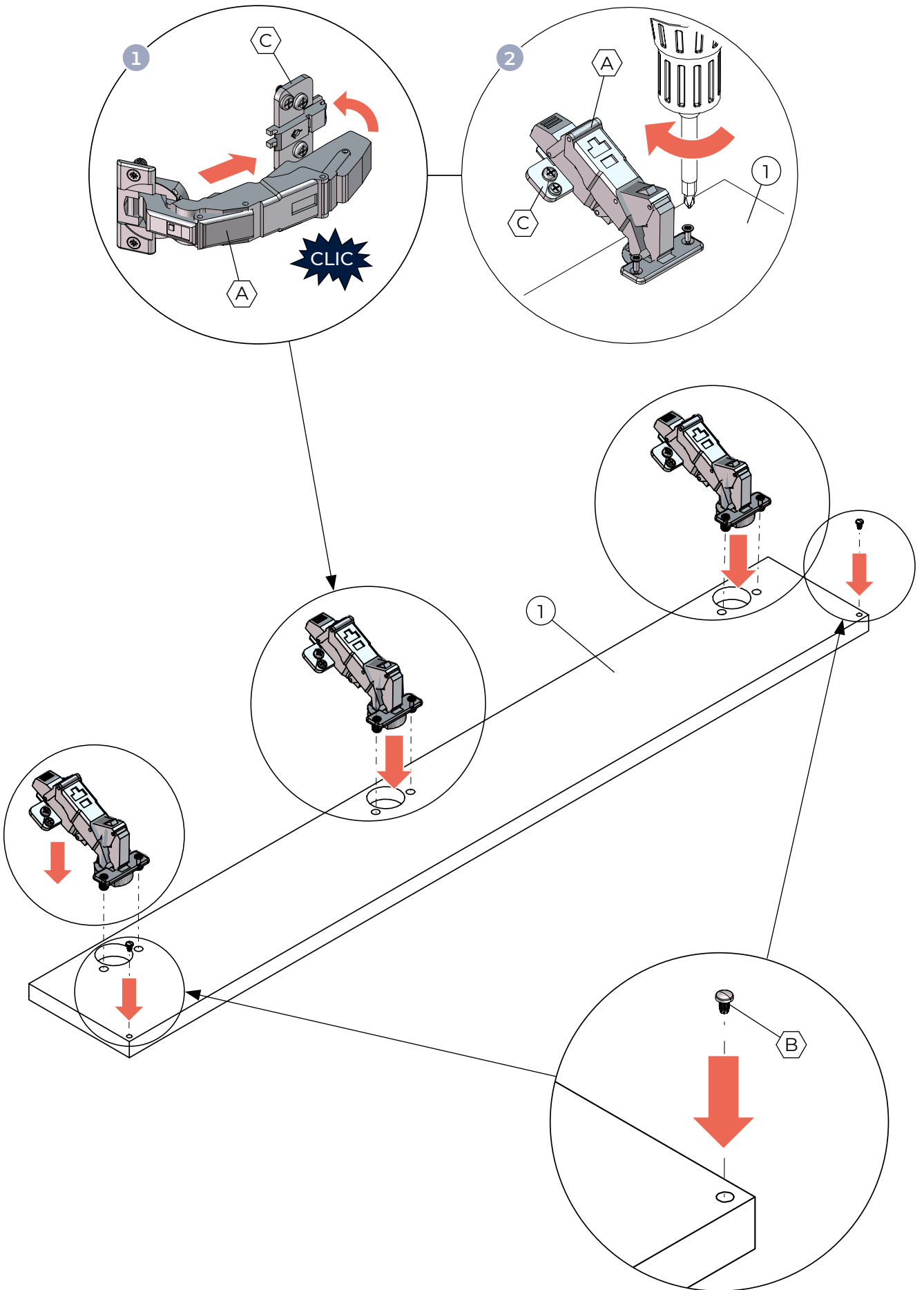

## 2 Montage porte principale / Main door assembly

Si charnières **A** : /  
If **A** hinges used:

OU / OR  
Si charnières **E** : /  
If **E** hinges used:

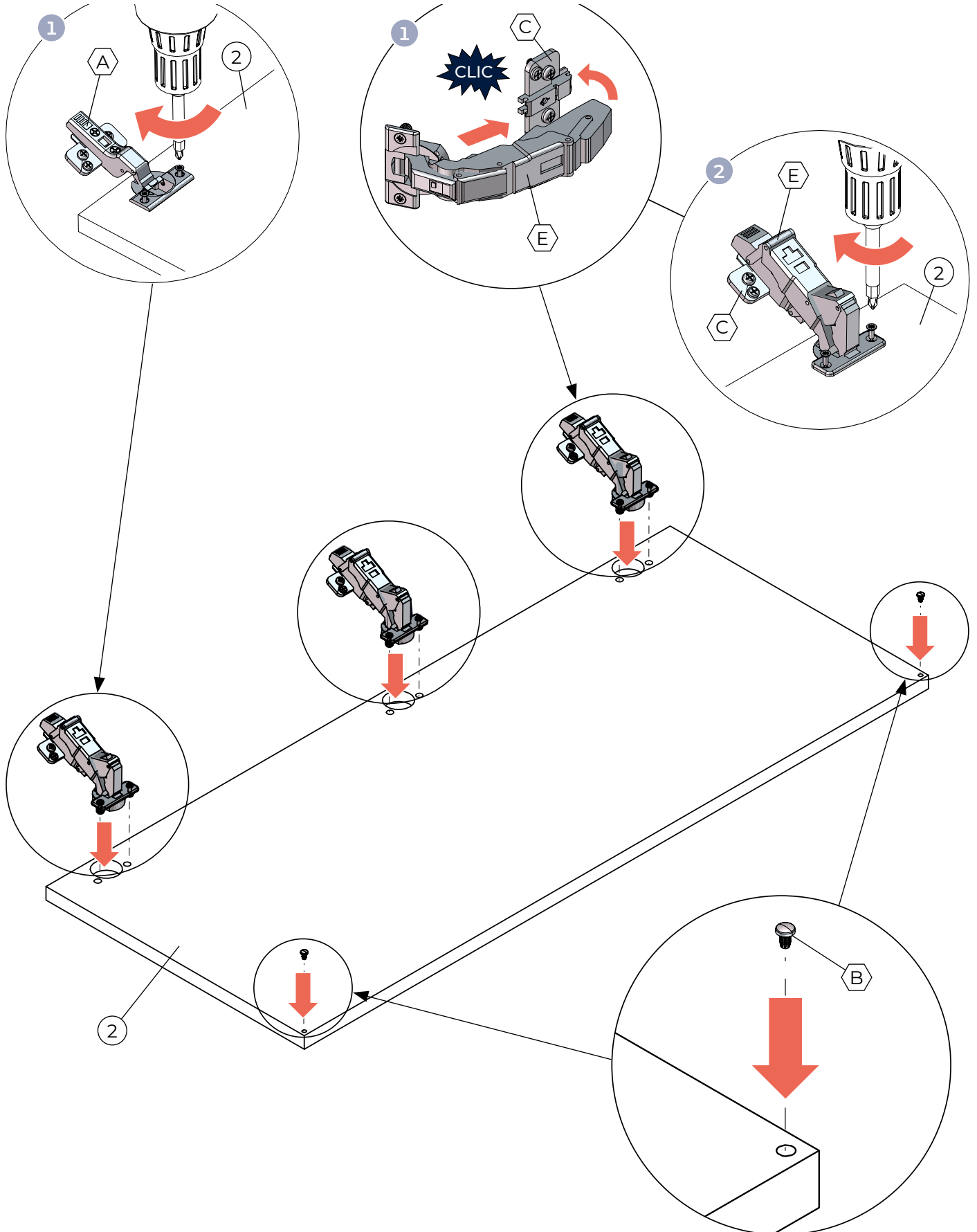

3

1

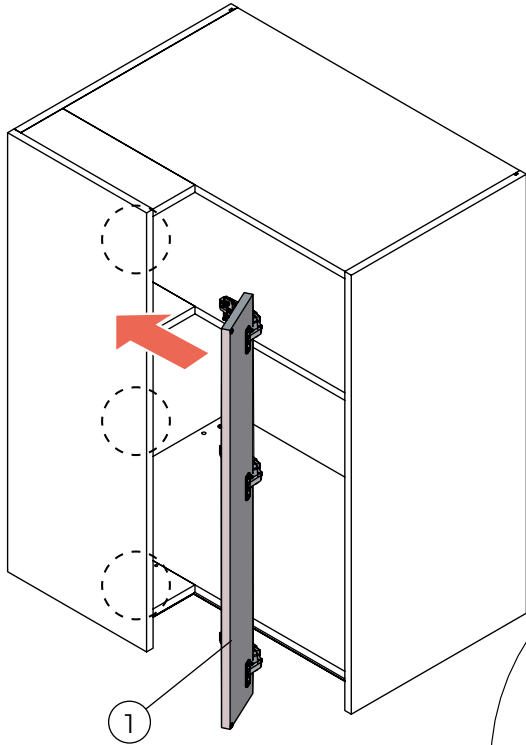

2

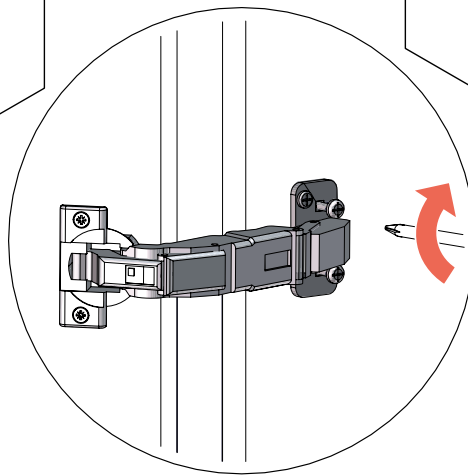
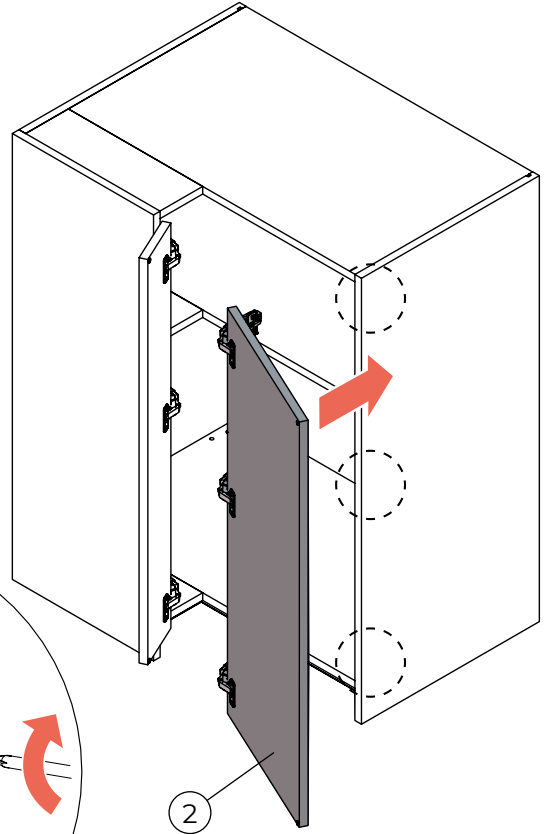

4

### Réglages / Adjustments

1

Façade retour / Corner door

Spécifiques selon charnières /  
Depends on hinges choice

2

Façade principale / Main door



# 6

## RÉGLAGE DES CHARNIÈRES / HINGES ADJUSTMENTS

p.23

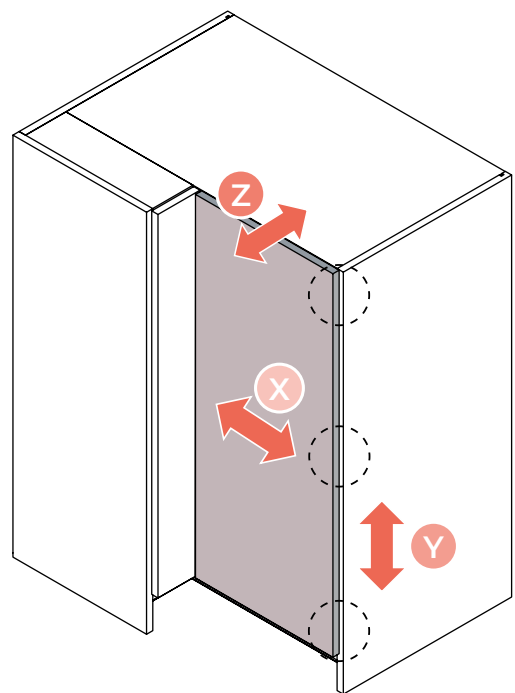
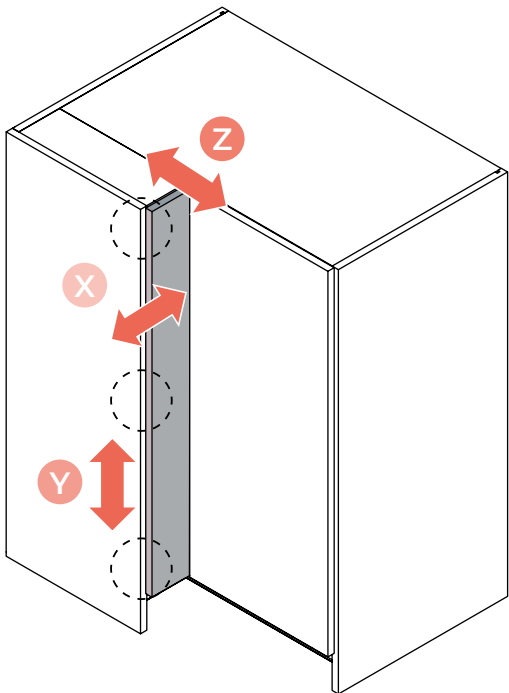

# 4 PORTE ABATTANTE AVEC VÉRIN / FLAP DOOR WITH CYLINDER

## GLOSSAIRE / GLOSSARY

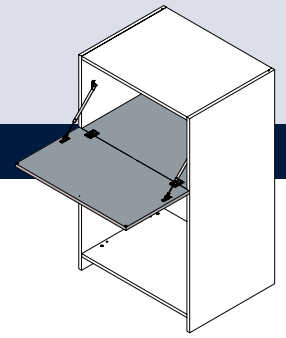

1	Abattant / Flap	2	Etagère de l'abattant / Flap shelf
---	-----------------	---	------------------------------------

**!** L'étagère de l'abattant 2 doit être montée en amont, au moment de l'assemblage du meuble. / Flap shelf 2 must be mounted upstream, at the time of the cabinet's assembly.

↓  
NOT\_0000593

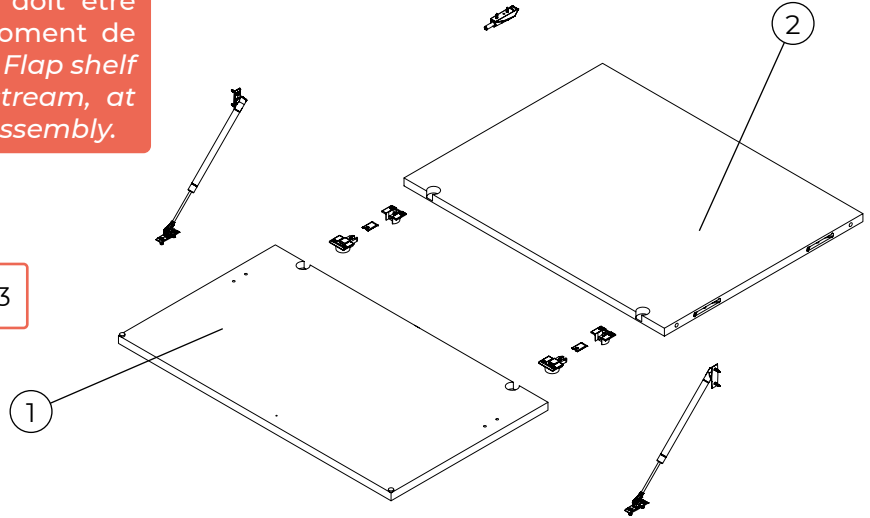

## QUINCAILLERIE / HARDWARE

**TLBDA**

**A**

A1	A2	A3	A4

**ENS001**

**B**

P09449011	P09449012	P09449013	P31001198
B1	B2	B3	Coloration noire Ø3,5x16 C

P31001198	P29454000	P41000143	P41000142
Coloration noire Ø3,5x16 C	Ø3,5x15 D	E	F
P31000362	P31000646	P31090700	
Ø7,4x10 G	H	M4Ø5x15 I	

P31001195 (longueur/length 164mm)  
P31001196 (longueur/length 244mm)  
P31001197 (longueur/length 355mm)

**J**

J1	J2	J3

1



Si nécessaire, réalisez cette étape lors de l'assemblage du meuble avec l'étagère d'abattant. /  
If necessary, do this step when assembling the cabinet with the flap shelf.

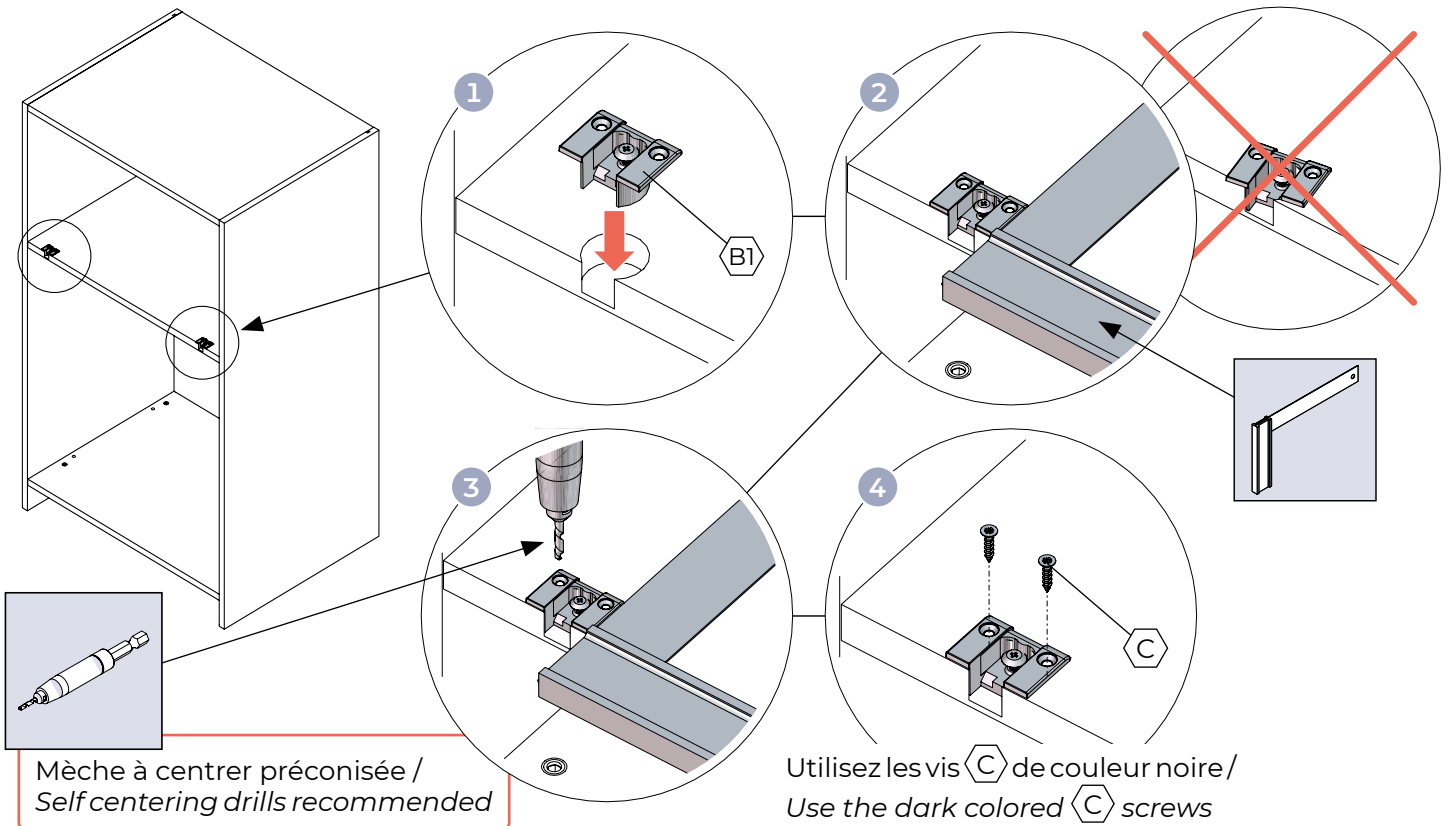

2

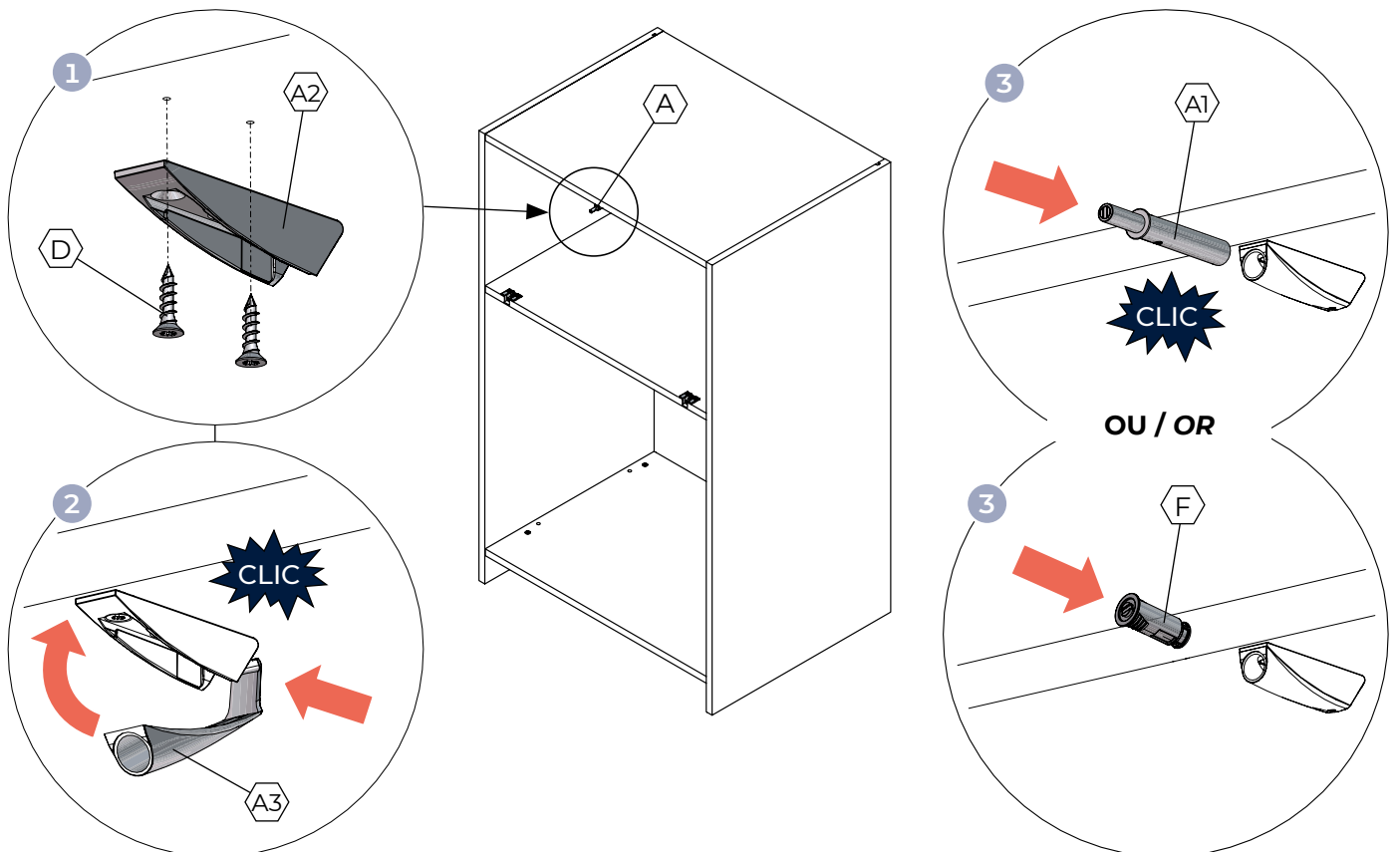

3

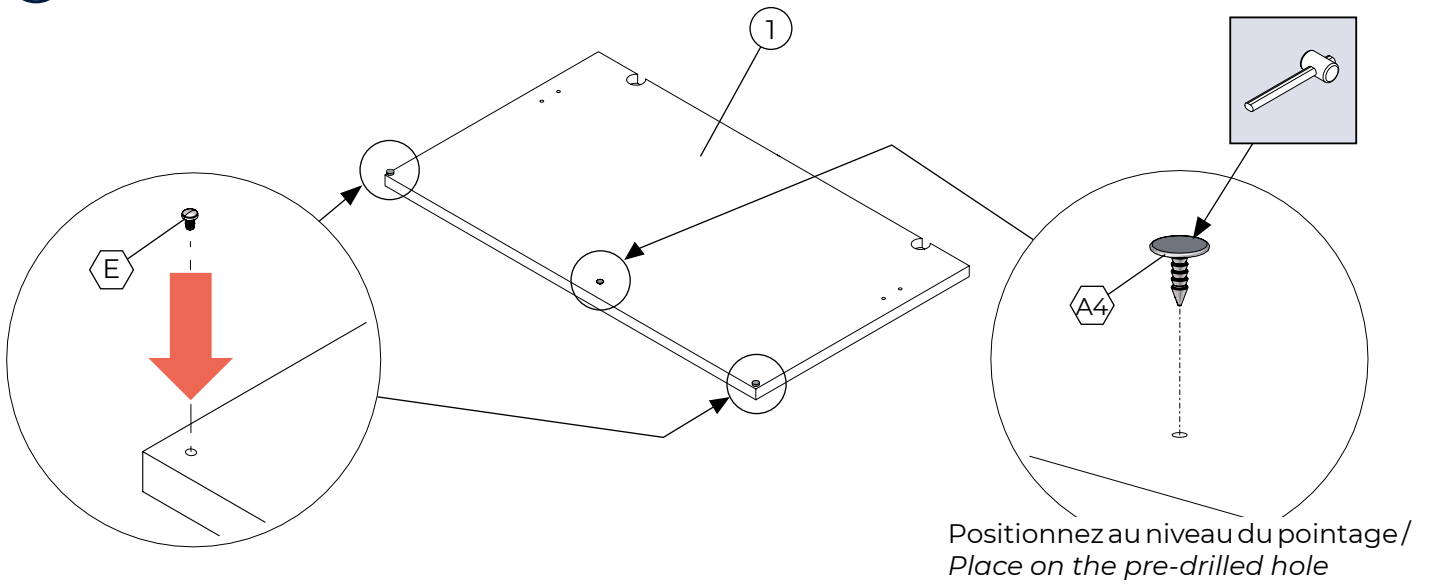

4

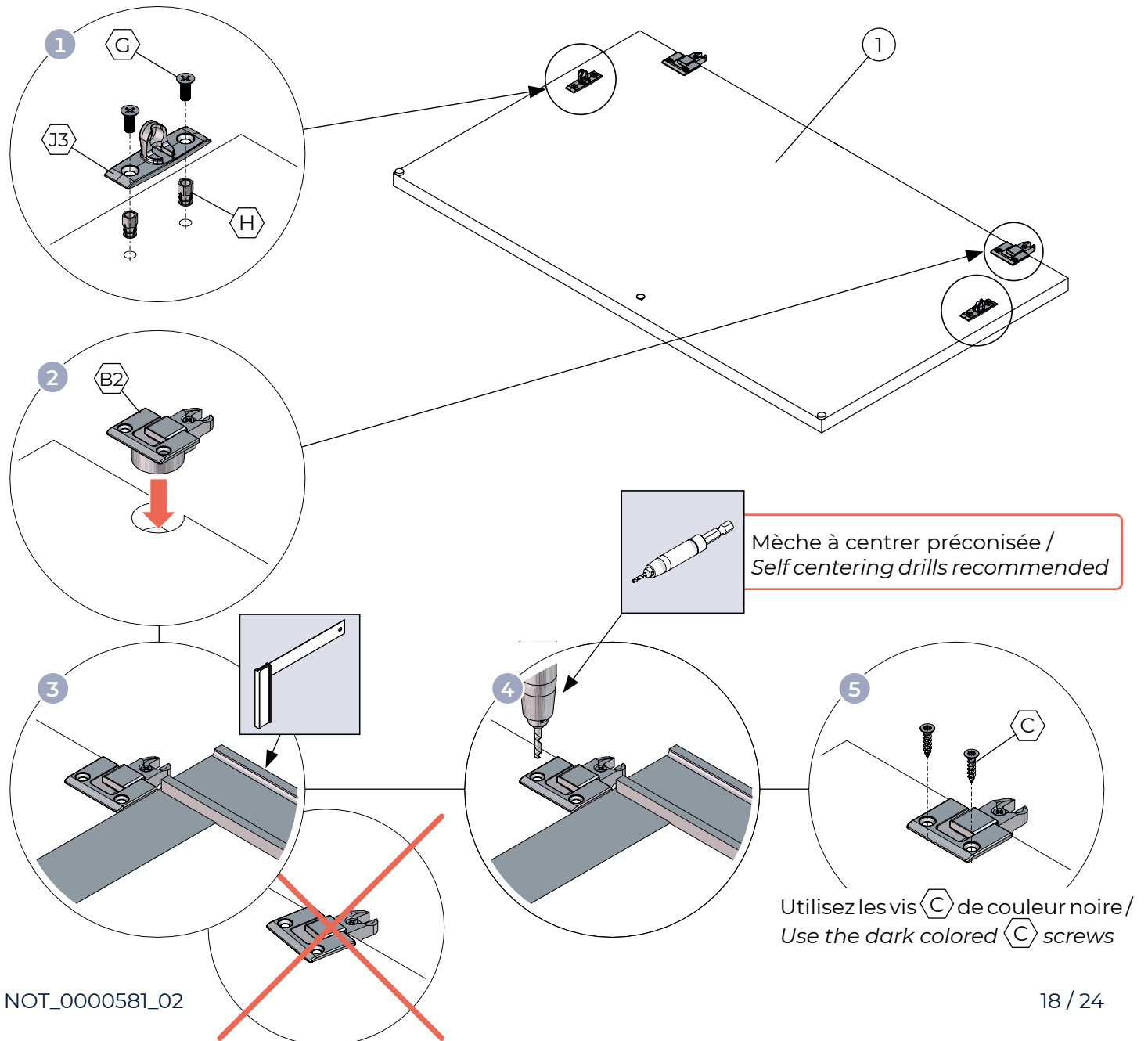

5

i

Si montage en face à face / If two elements are facing each other through the column

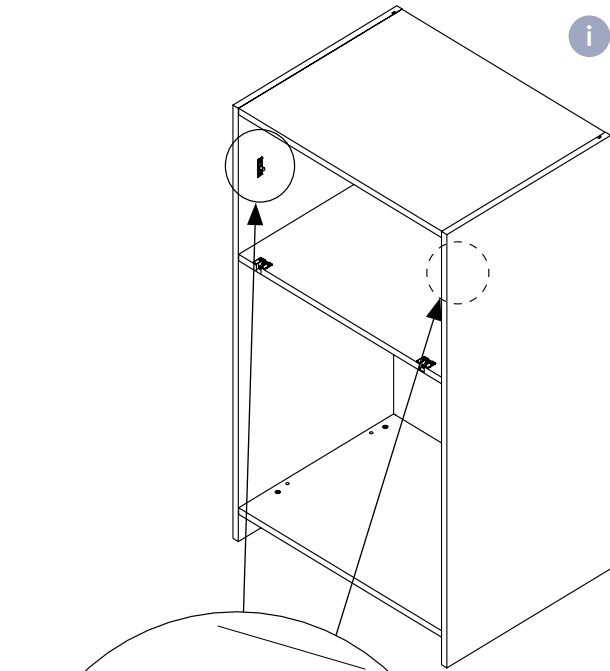

Utilisez les vis **C** de couleur noire / Use the dark colored **C** screws

1

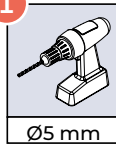

2

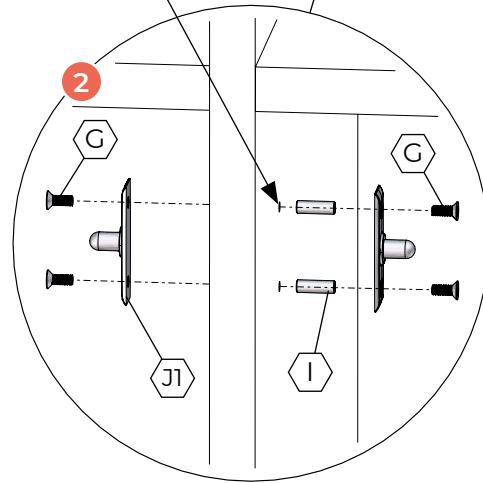

6

1

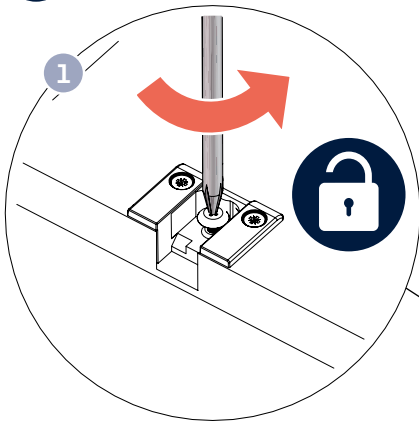

2

1

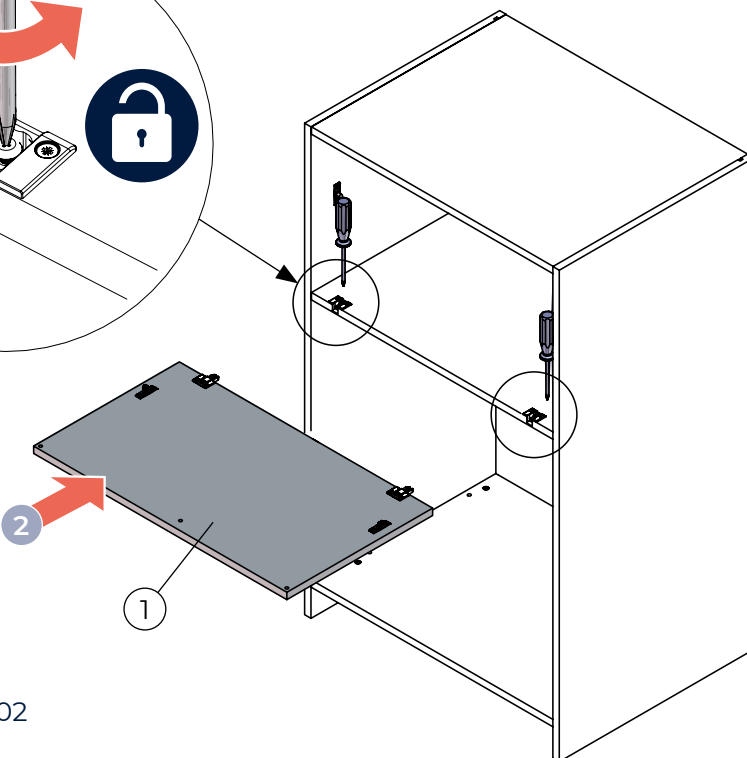

3

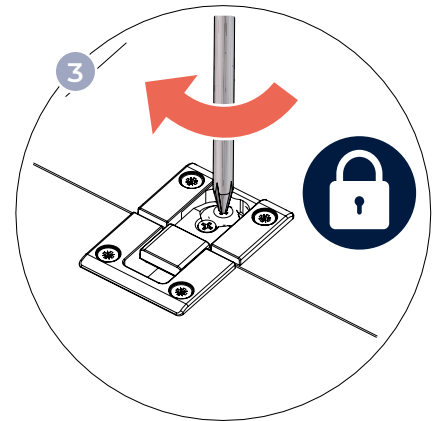

## 7 Installation des vérins / *Cylinders installation*

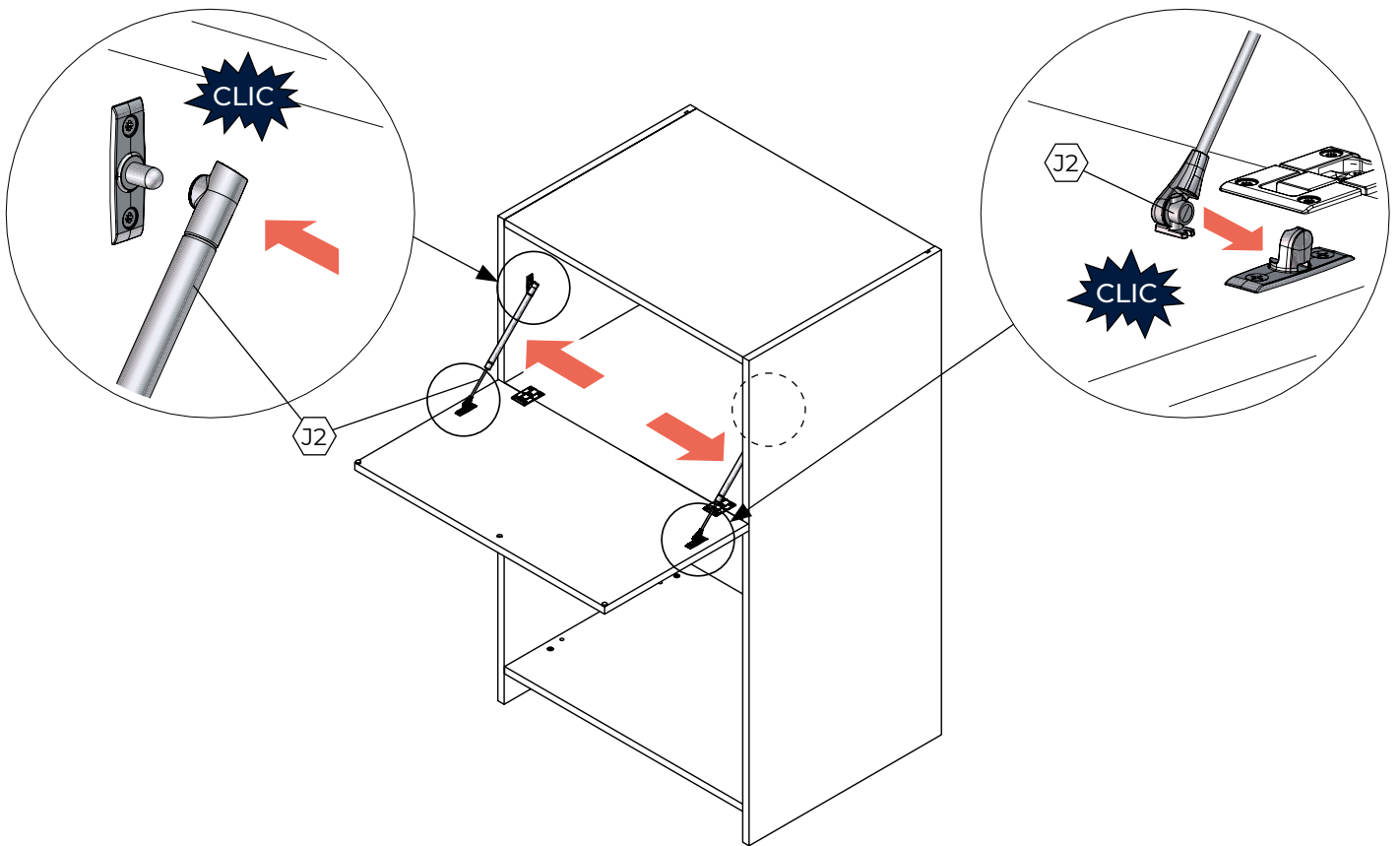

## 8 Réglages / *Adjustments*

1

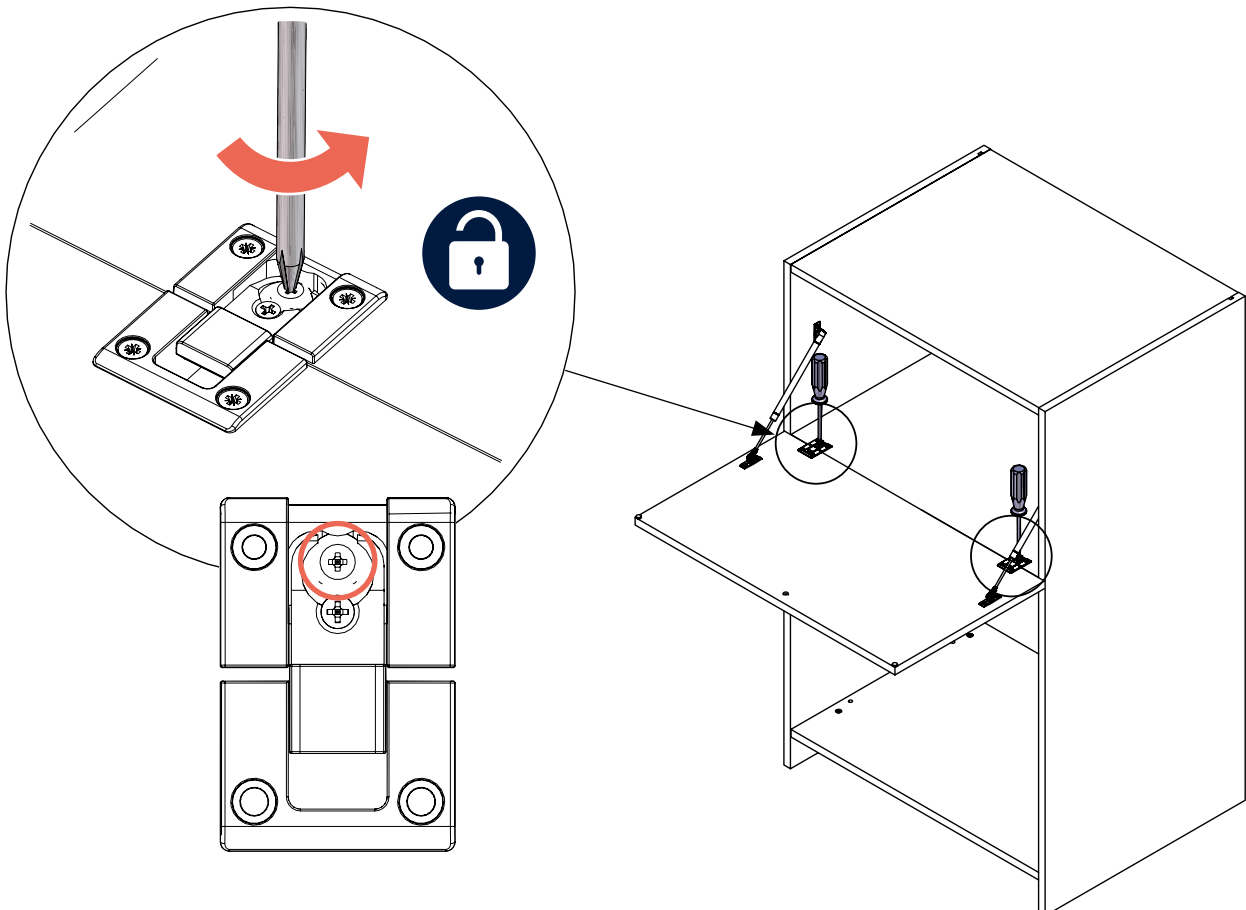

2

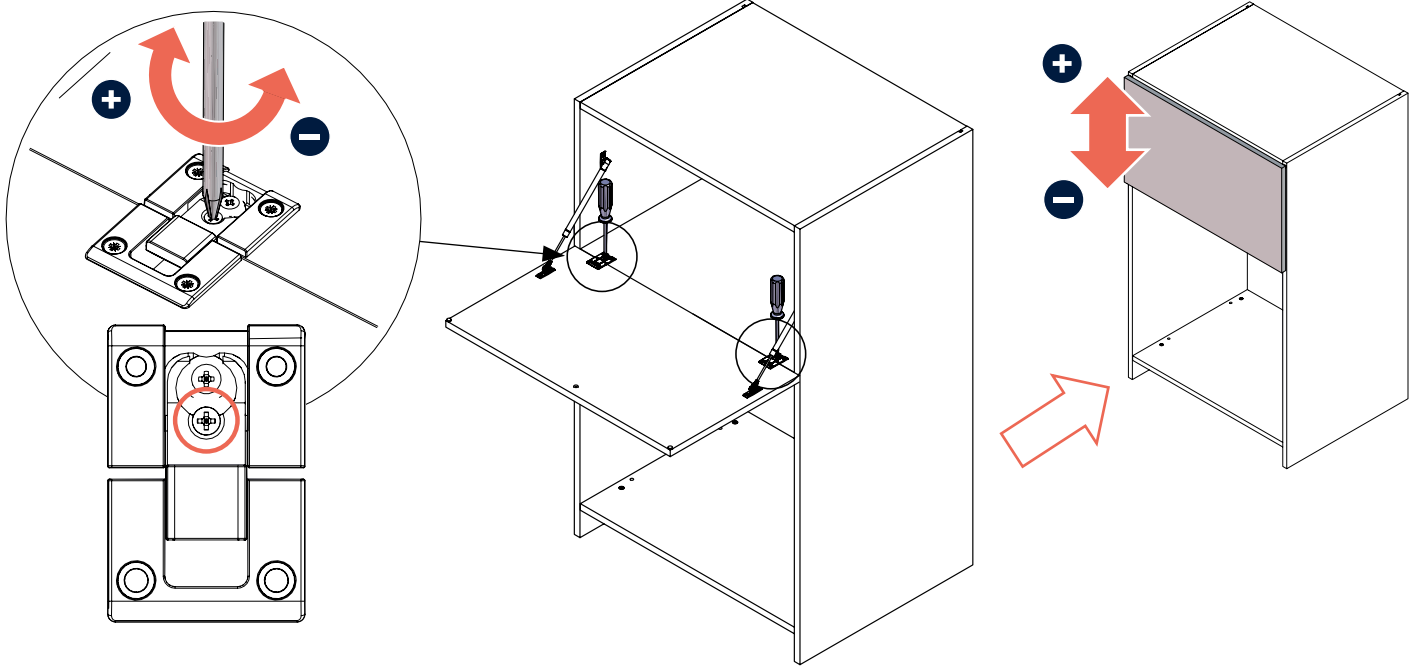

3

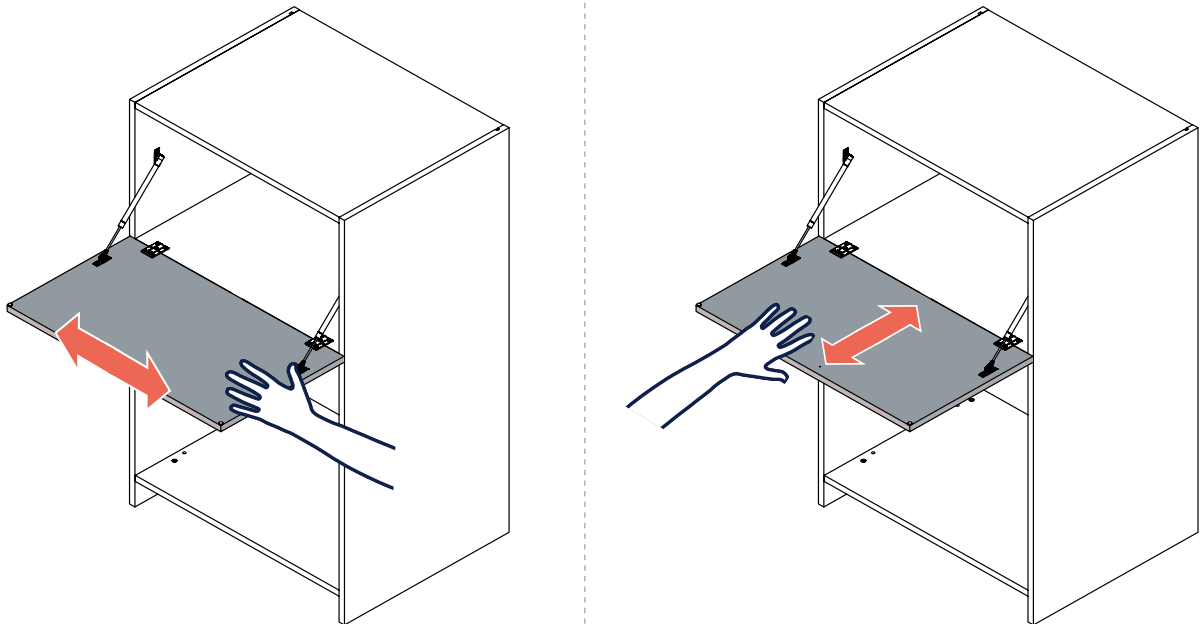

4

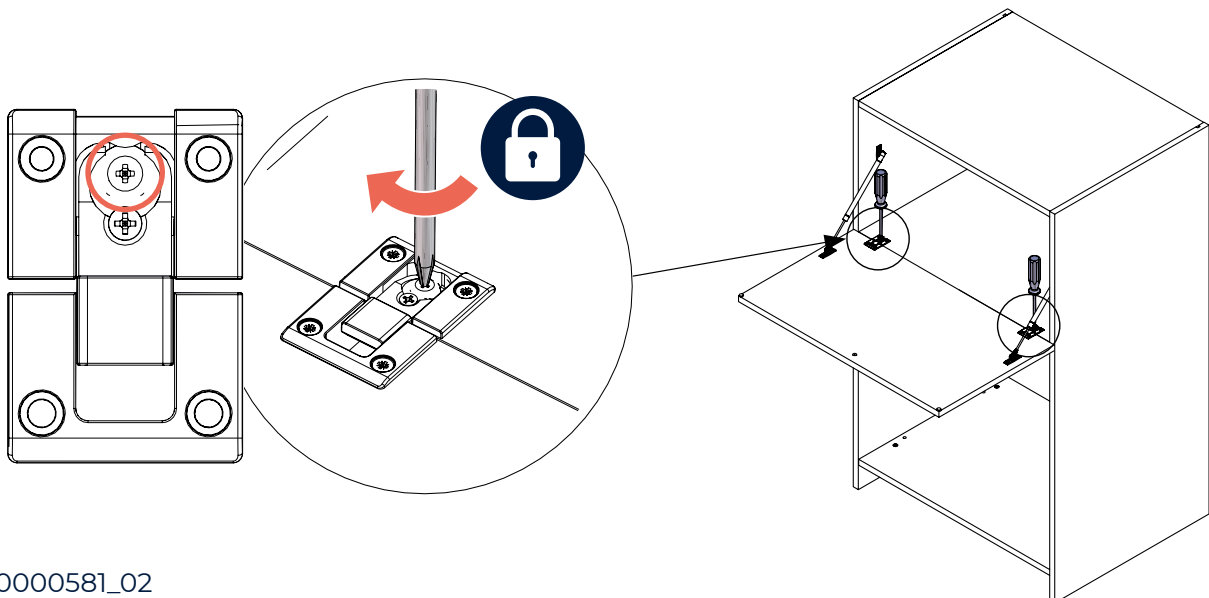

9

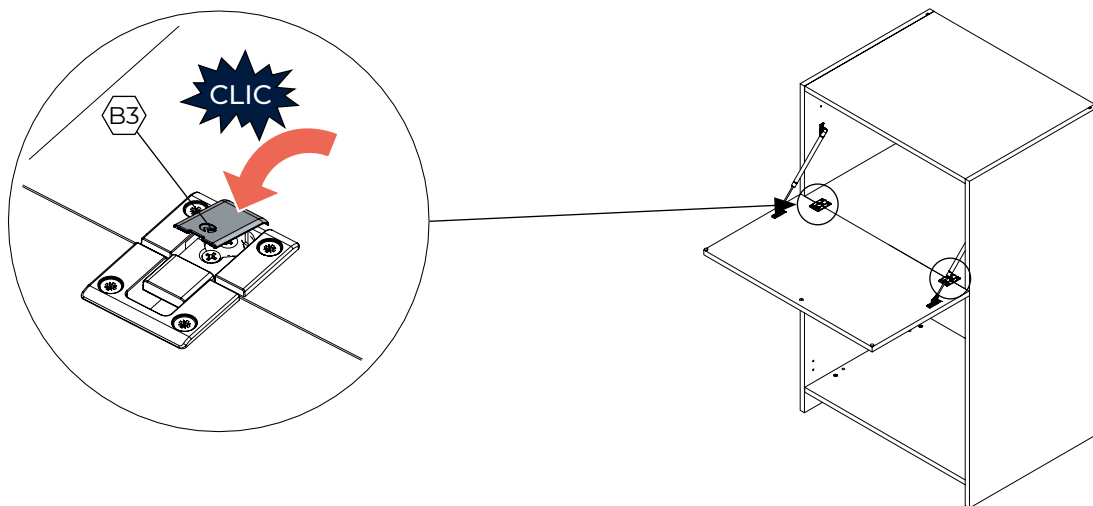

10 Réglages de la force d'ouverture / Opening strenght adjustment

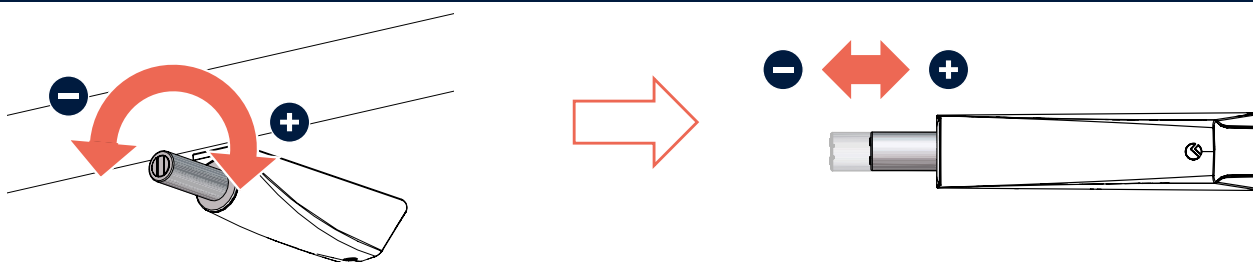

5 PORTE ABATTANTE SANS VÉRIN / FLAP DOOR WITHOUT CYLINDER

GLOSSAIRE / GLOSSARY

1 Abattant / Flap

2 Etagère de l'abattant / Flap shelf

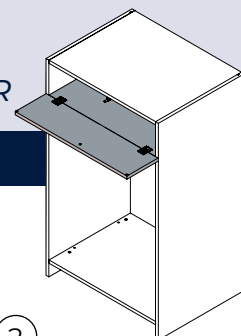

L'étagère de l'abattant 2 doit être montée en amont, au moment de l'assemblage du meuble. / Flap shelf 2 must be mounted upstream, at the time of the cabinet's assembly.



NOT\_0000593

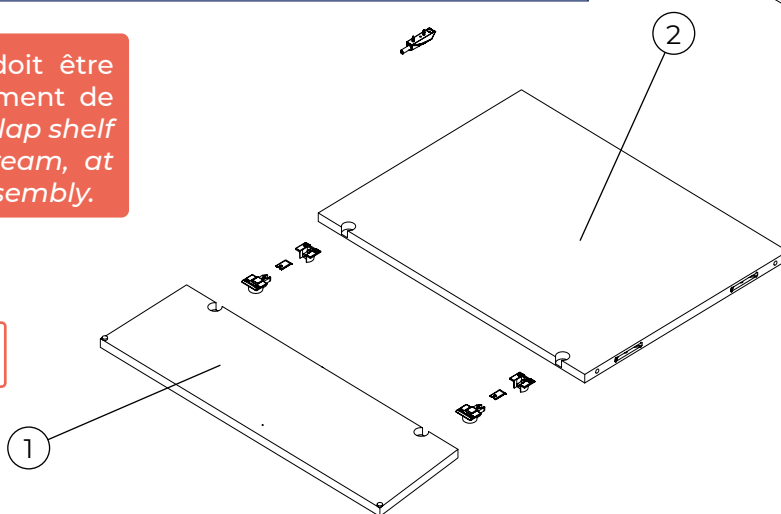

1

Suivre les étapes / Follow the steps



4 PORTE ABATTANTE AVEC VÉRIN / FLAP DOOR WITH CYLINDER

p.16

sauf / except



# 6 RÉGLAGES DES CHARNIÈRES / HINGES ADJUSTMENTS

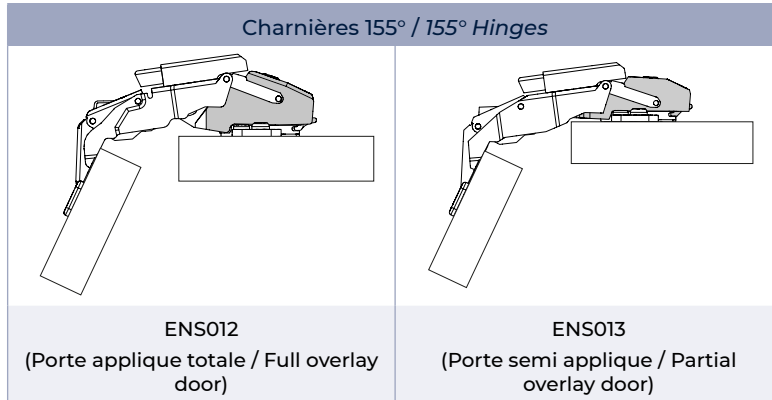
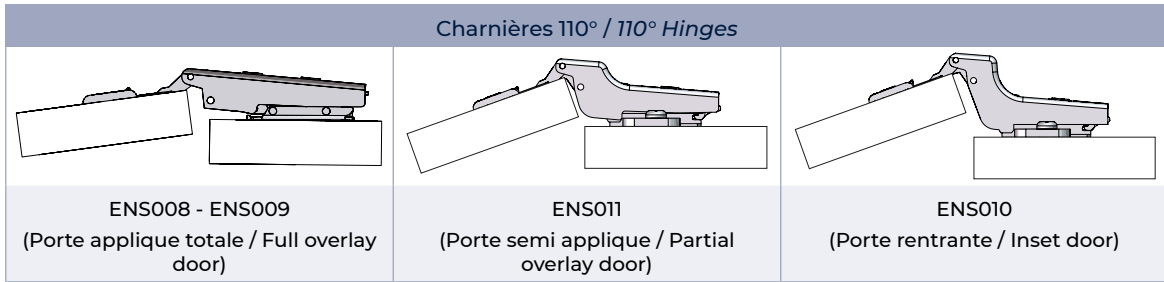

OUTILLAGE NON FOURNI / NOT SUPPLIED

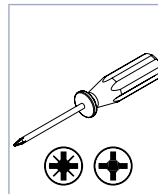

## 1 Charnières 110° / 110° Hinges

### 1 Montage / Assembly

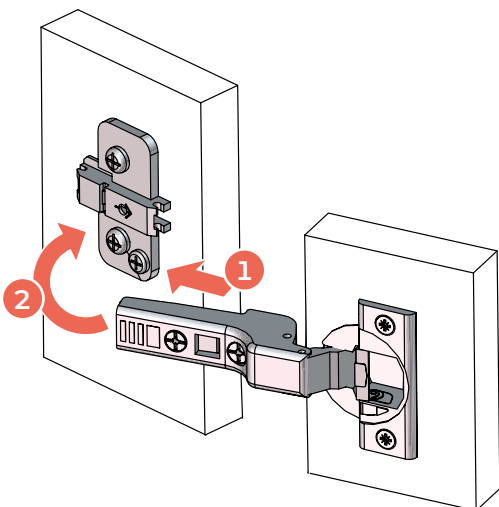

### 2 Réglages / Adjustments

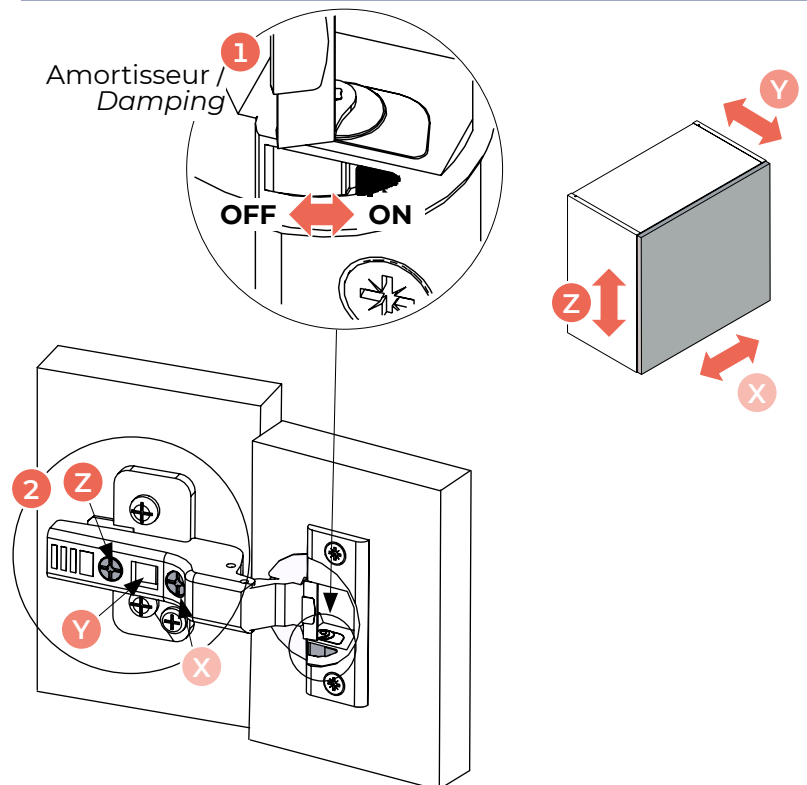

## 2 Charnières 155° / 155° Hinges

### 1 Montage / Assembly

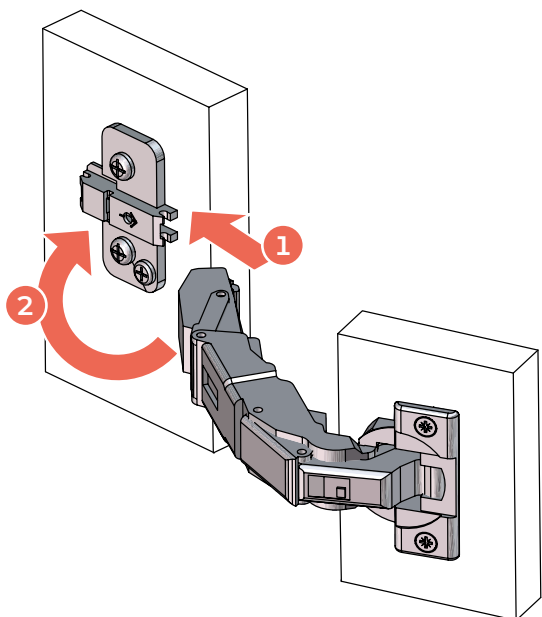

### 2 Réglages / Adjustments

